

Pilot X/S

Wireless Digital Teaching Station



Pilot X

Intel® Core™ i5
Intel® Core™ i7

Pilot S

Qualcomm
SC8180XP

Powered by **Qualcomm**

In a Hurry?

Watch the **Pilot X/S Quick Start Video**
Go to www.hovercam.com/support/training-videos

or

Scan this QR code with your phone's camera:



Pilot X/S Quick Start Video

Pilot X
Intel® Core™ i5 | Intel® Core™ i7

Powered by



Pilot S
Qualcomm SC8180XP

Powered by



Qualcomm and the Qualcomm logo are trademarks of Qualcomm Technologies, Inc and/or its or its affiliated companies.
Intel and the Intel logo are trademarks of Intel Corporation or its subsidiaries.

© Copyright 2022 Hovercam®. All rights reserved. Hovercam® is a trademark Pathway Innovations, Inc. This user guide is subject to change without notice. Depicted product appearance, features and specifications may vary in the final product(s). Hovercam® shall not be liable for technical or editorial errors or omissions contained herein. Hovercam® disclaims all responsibility and liability for the distribution of and/or reliance on this datasheet. The following granted or pending patents have been filed by pathway Innovations, Inc. (D.B.A. Hovercam) with the United States Patent and Trademark Office (USPTO): <https://www.hovercam.com/patents>. Rev. 220308

Welcome	3
Main Features What's in the Box	3
Podium Diagram	4
Tablet Diagram	5
Assembling the Podium	6-7
Moving and Adjusting the Podium	8
Charging the Podium	9
Charging the Tablet	10-12
Charging the Tablet Dock	10
Charging the Tablet Storage Bay Changing the Combination	11
Removing the Tablet Charging with the Tablet Power Adapter	12
Operating the Tablet	13-16
Powering-On Operating the Touchscreen Using the Active Stylus	13
Internal PC Windows 10 Imaging / Formatting	14
Tablet Mode Thumb Strap	15
Using the Pop-Out Keyboard & Digital Keyboard Using Third Party Accessories ...	16
Document Camera	17-18
Deploying Positioning.....	17
Software Operating	18
Connecting to a Display: HoverCast	19-22
HoverCast Wireless HDMI How Does HoverCast Work?.....	19-20
HoverCast Set-Up	21
HoverCast FAQ'S Troubleshooting	22
HoverCast Positioning Guide	23-25
Connecting to a Display: Wired	26
Audio Output	27-29
Built-in Speakers Output Display's Speakers HDMI Audio De-Embedder	27
Tablet / Podium Audio Line In/Out (wired) Bluetooth.....	28
Built-In Microphone Auxillary Microphone USB Microphone Bluetooth.....	29
Technical Specifications	30
Service and Support	31
Warranty	32-33
Safety Warnings	34-36
Notices	37
Legal	38

3 Welcome

Congratulations! With **Pilot X/S**, you've taken a major step in revolutionizing your classroom. Designed by educational technology professionals in California, the **Pilot X/S** brings every essential educational technology component to your fingertips: a tablet computer, document camera, and wireless podium. Say goodbye to messy cables, because with **Pilot X/S**, you can wirelessly control your classroom display from anywhere in the room.

Main Features

- Microsoft® Windows® 10 tablet computer (license not included), powered by Intel® (Pilot X)
- Microsoft® Windows® 10 ARM 64 (S Mode) tablet computer, powered by Qualcomm (Pilot S)
- 13.3" Multitouch display, with #2 pencil stylus capability
- Wireless, lag-free HD casting via HoverCast
- Wirelessly control and cast bi-directional annotations from USB-touch enabled displays
- Fold-out 4K document camera
- Mobile podium charging station for up to 6 hours of wireless use
- Tablet dock with built-in keyboard
- Lockable tablet bay for overnight security and charging

What's in the Box

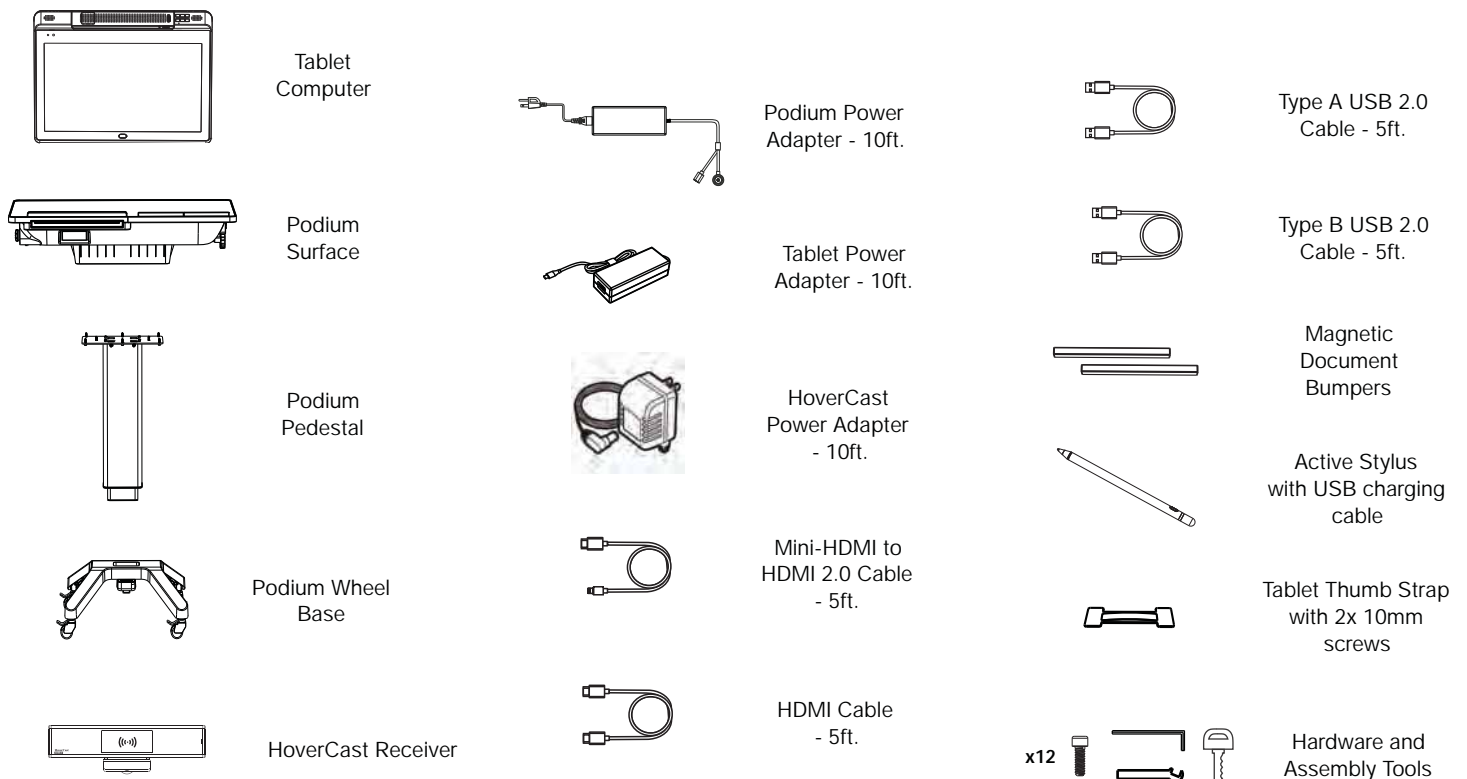

- 1 Magnetic Tablet Dock
- 2 Pop-Out Keyboard
- 3 Tablet Bay Charging Actuator
- 4 x2 Magnetic Anti-Slip Bumpers
- 5 Tablet Storage Bay
- 6 Tablet Bay Key Lock
- 7 Podium Audio Line In/Out
- 8 Magnetic Power Port
- 9 Tilt Adjustment Dial
- 10 4x Lockable Wheels
- 11 Height Adjustment Foot Pedal

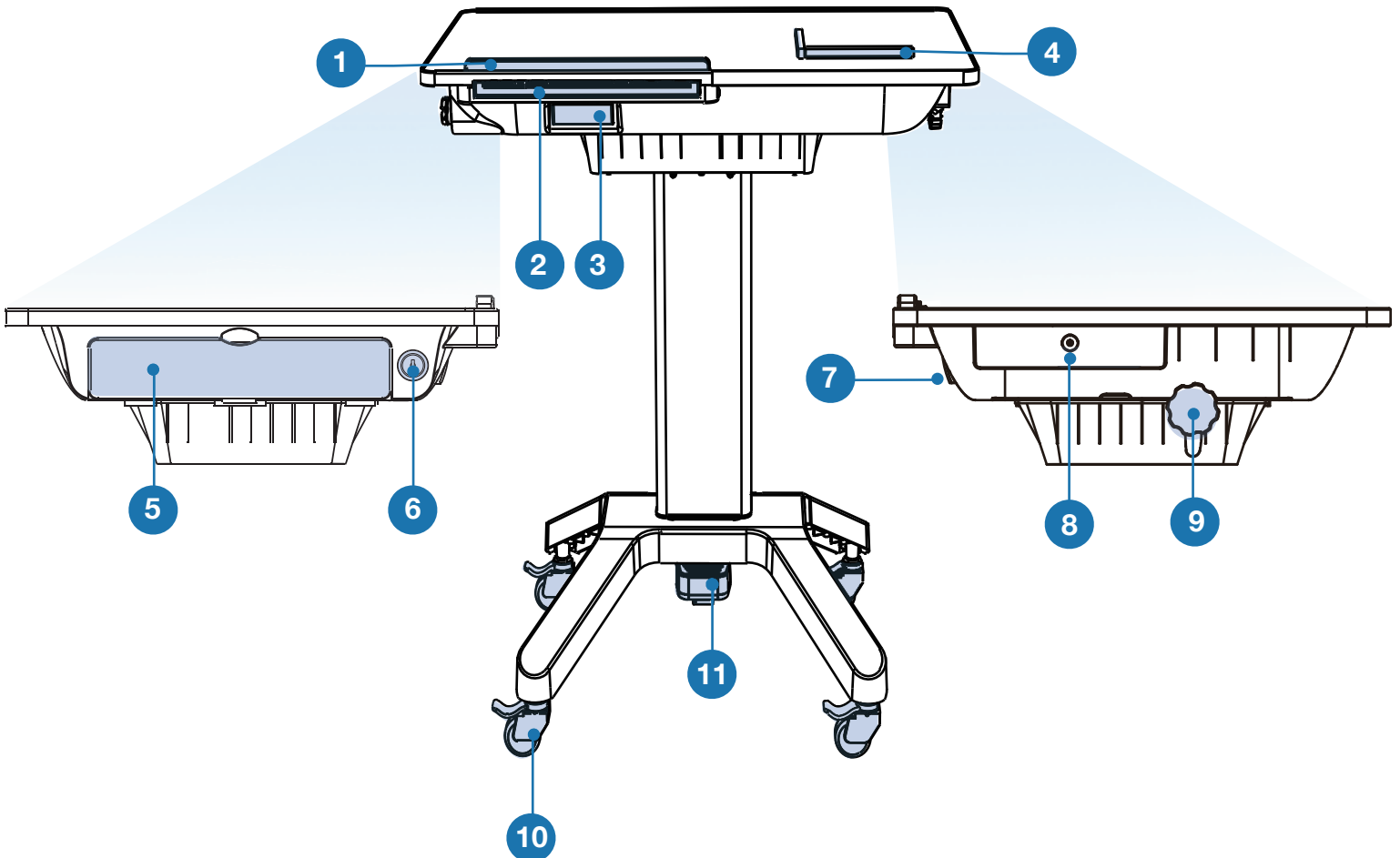

5 Tablet Diagram

Tablet Features

- 1 Fold-Out Document Camera
- 2 HoverCast Wireless Antenna
- 3 HoverCast Antenna On/Off
- 4 1 Watt Tablet Speaker (2x)
- 5 Tablet Charging Indicator*
- 6 Kensington Lock
- 7 HoverCast Reset
- 8 13.3" Multi-Touch Display
- 9 Fingerprint Scanner / Menu*
- 10 Tablet Sleep/Wake Button

Camera Controls

- 11 Zoom-In
- 12 AutoFocus On
- 13 Image Flip
- 14 Zoom-Out
- 15 Camera Reset
- 16 AutoFocus Lock
- 17 Freeze

Connectivity

- 18 USB 3.0 Type A (2x) - Pilot X
USB 3.0 Type A (2x) - Pilot S
- 19 USB 3.0 Type C (2x) - Pilot X
USB 3.0 Type C (1x) - Pilot S
- 20 TF Card Slot (1x) - Pilot S**
- 21 Audio Line In/Out (x1) - Pilot X/S
- 22 Magnetic Docking Connector

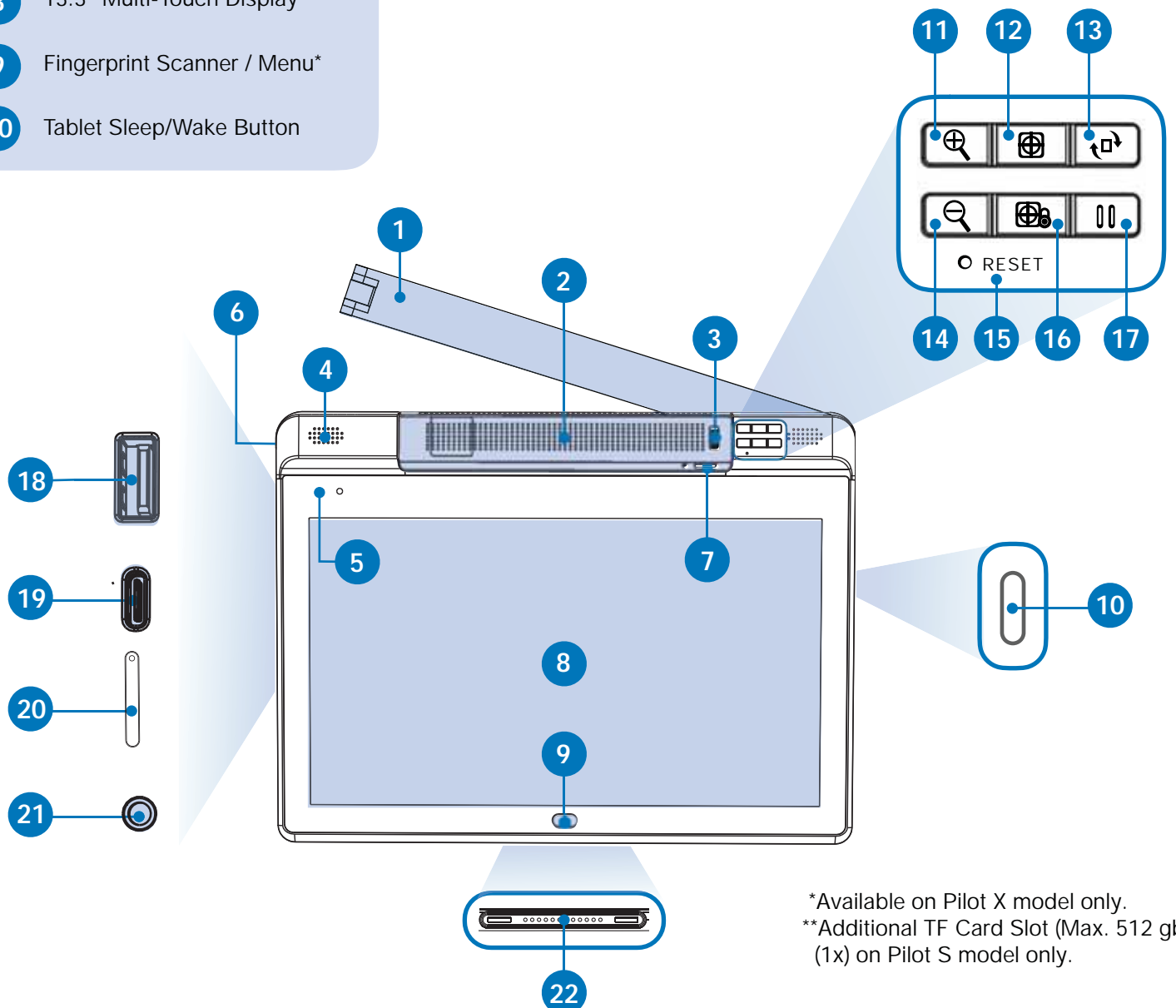

*Available on Pilot X model only.
**Additional TF Card Slot (Max. 512 gb) (1x) on Pilot S model only.

Notice: Two people are required to safely assemble Pilot X/S



Step 1

Carefully unpack the **Pilot X/S Podium Surface, Podium Pedestal, Podium Wheel Base, Hardware** and **Assembly Tools**. Stage the components on the included foam packaging, or use a padded surface.

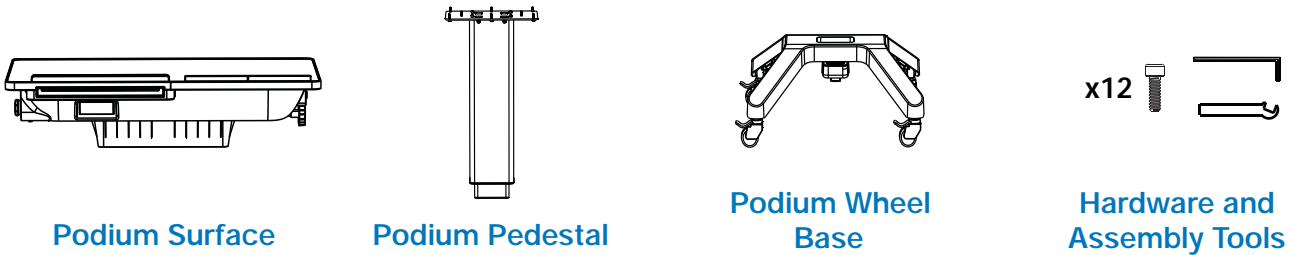

Step 2

Place the **Podium Surface** upside down on a padded surface, making sure the **Tilt Adjustment Dial** is in the locked position by rotating it clockwise to the furthest position.

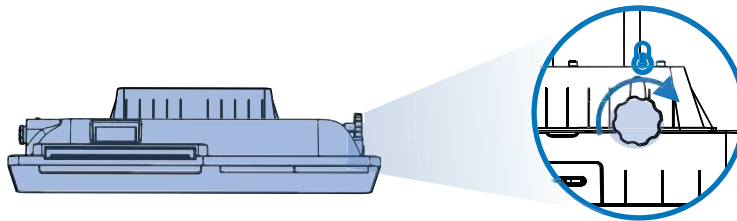

Step 3

Carefully place the **Podium Pedestal** onto the **Podium Surface**, making sure the 8x 4mm bolt holes line up properly. Next use the included **hex driver** to secure **8x 4mm Bolts** as pictured below, being careful not to strip the threads.

Optionally, a thread-locking compound may be used to prevent loosening of the bolts over time (not included). Loctite® Threadlocker Blue 242® is a recommended compound.

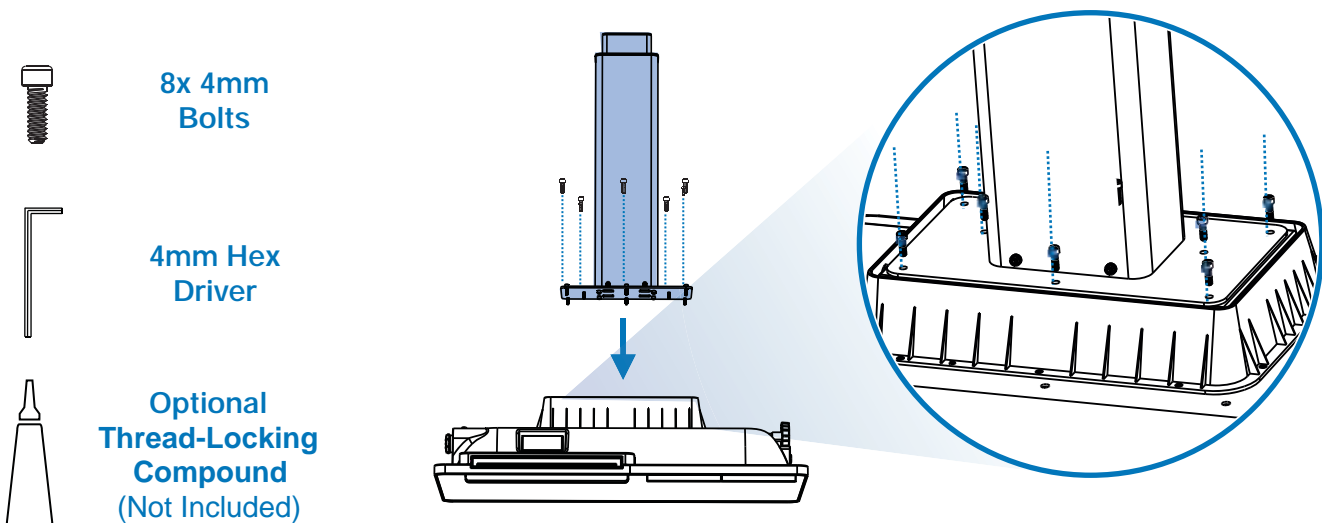

7 Assembling the Podium

Step 4

Insert the **Podium Wheel Base** onto the **Podium Pedestal**, making sure the **Height Adjustment Foot Pedal** is on the same side as the **Pop-Out Keyboard**. Use the included **Hex Driver** to secure **4x 4mm bolts** as pictured below, being careful not to strip the threads.

Optionally, a thread-locking compound may be used to prevent loosening of the bolts over time (not included). Loctite® Threadlocker Blue 242® is a recommended compound.



4x 4mm
Bolts



4mm Hex
Driver



Optional Thread-
Locking
Compound
(Not Included)

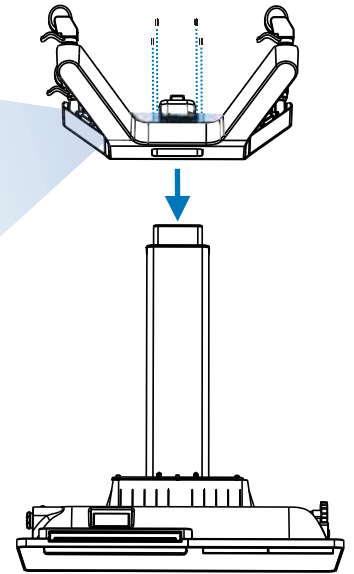
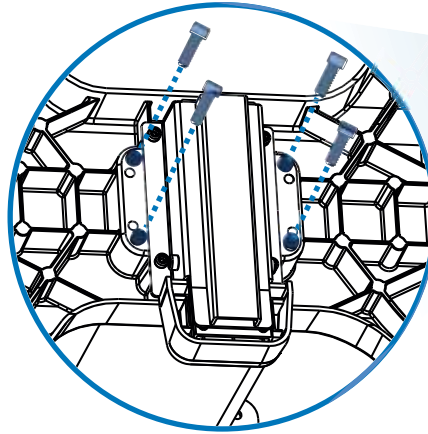

Step 5

Ensure that the 4x **Podium Wheels**' levers are in the locked position by pulling up on the locking levers.

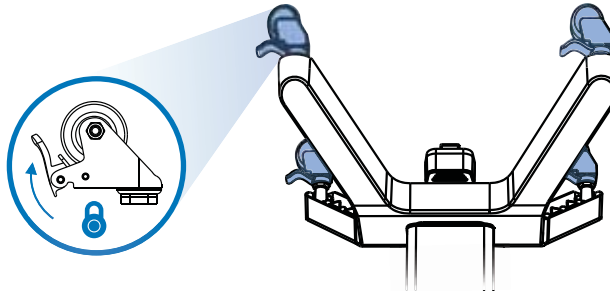

Step 6

With the help of another person, carefully stand the podium onto a level surface.

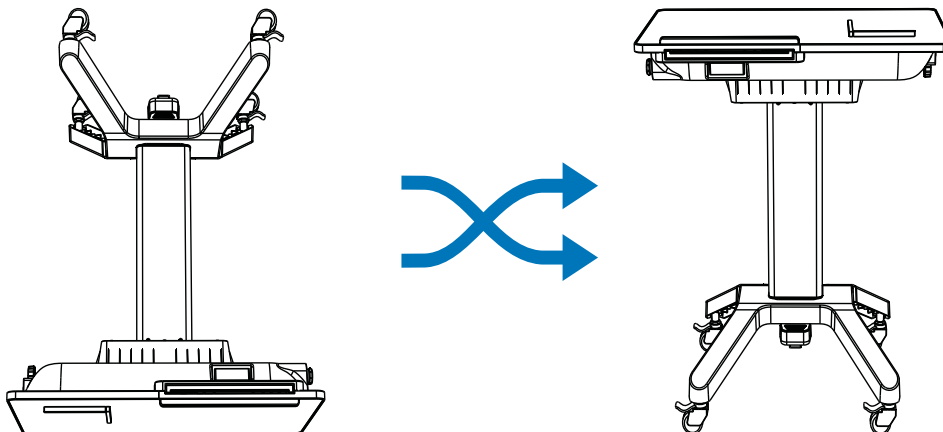

The Pilot X/S Podium is adjustable for a variety of usage models. It can be used as a desk, a presentation lectern, a mobile teaching station, and more.

Moving the Podium

To move the podium, unlock the 4 wheels on the **Podium Wheel Base** by pulling up on the levers with the top of your foot. Use two hands to slowly and carefully push the podium to the desired location, and re-lock the 4 wheels once in position.

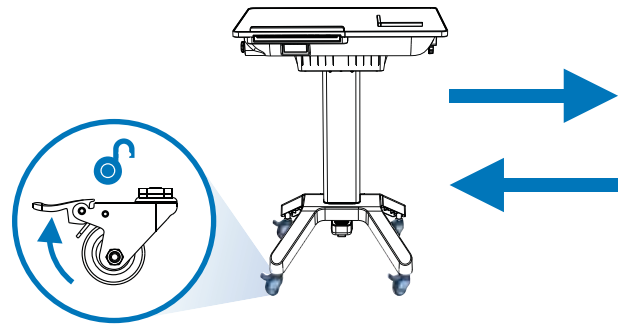

Adjusting Height

The podium uses an internal pneumatic cylinder to make height adjustments easy. Height can range between 32 - 46 inches. To adjust the height, simply press the **Height Adjustment Foot Pedal** and push down or pull up on the **Podium Surface** with two hands. Release the foot pedal when the desired height is reached.

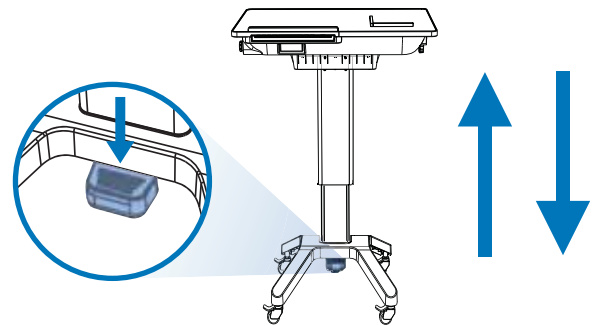

Adjusting Tilt Angle

You can easily adjust the **Podium Surface's** tilt angle to three settings: 0° (flat), 10°, and 20°. To adjust the tilt, first unlock the **Tilt Adjustment Dial** by turning it counterclockwise. With the wheel unlocked, use two hands to carefully tilt **Podium Surface** to the desired tilt angle. When you are done adjusting the tilt angle, it's important to re-lock the **Tilt Adjustment Dial** by turning it clockwise until the lock engages.

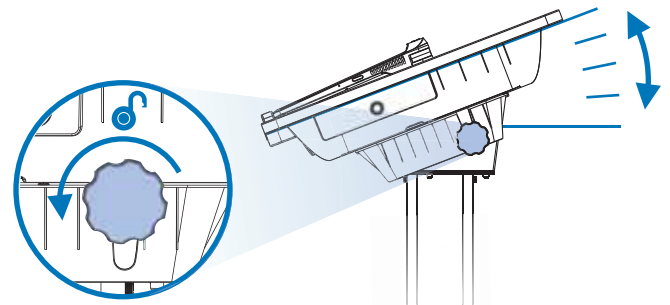

Magnetic Anti-Slip Bumpers

When using the podium in the tilted position, the included **Magnetic Anti-Slip Bumpers** can be used to keep papers and other objects from sliding off the podium. Because the **Podium Surface** is ferromagnetic, the bumpers can affix anywhere on the glass surface.

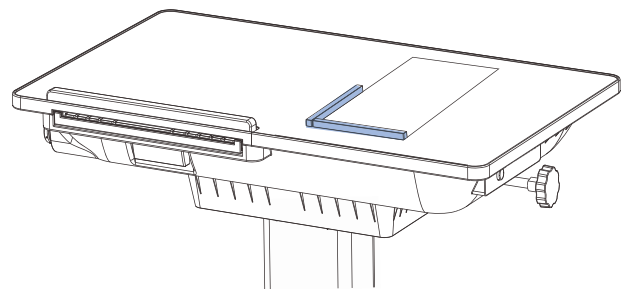

9 Charging the Podium

The **Pilot X/S Podium** features an internal battery that can charge the tablet while docked or stored in the tablet bay. This dual-charging feature extends the tablet battery life, allowing for up to 6 hours of use (depending on the usage model). The podium should be charged overnight for sufficient battery life throughout the day. When used alone, the tablet can achieve up to 3 hours of use under standard operating conditions. To conserve battery life, make sure the document camera is folded away when not in use (Page 17).

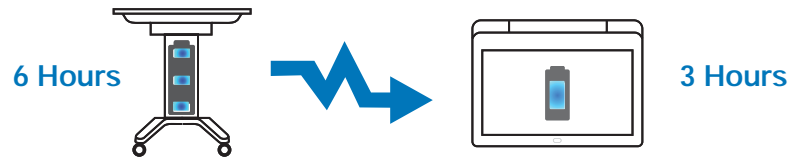

To charge the Podium, plug the **Podium Power Adapter** into an available A/C Power Outlet. Next, connect the charging connector to the **Podium Charging Port** on the right side of the podium.

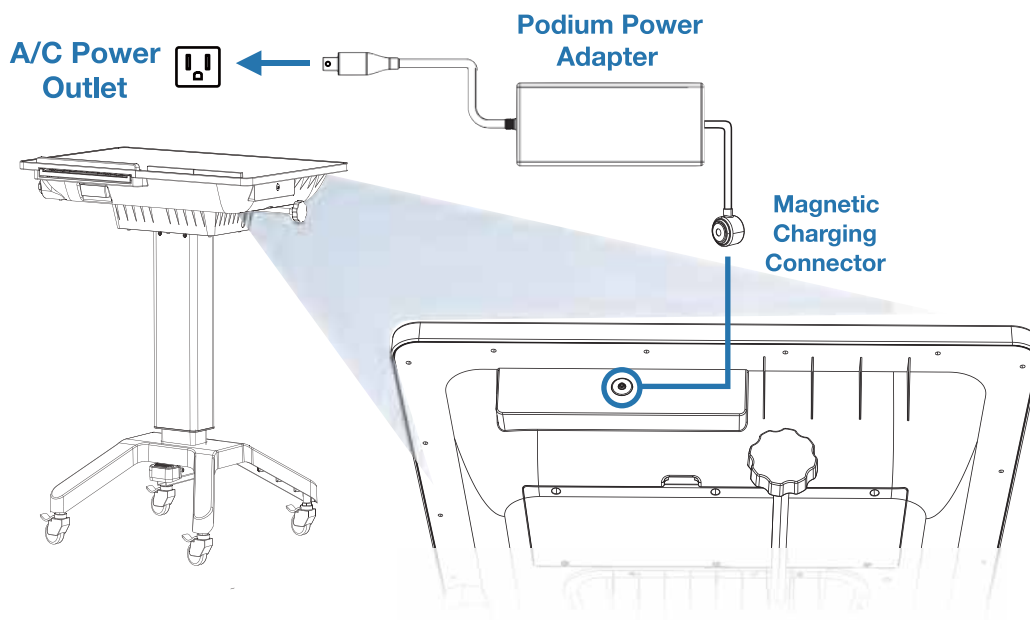

The **Podium Charging Indicator** is located on the upper left corner of the **Podium Surface**. When the podium is receiving a charge, the three blue lights on the "Pilot Internal Battery" charging indicator will flash in succession. If the indicator is not lighting up, ensure the **Podium Power Adapter** is connected properly.

When the podium is disconnected from the **Podium Power Adapter**, the **Podium Charging Indicator** will show the current battery level. Three solid blue lights mean that the podium battery is at 75%-100% of its capacity; Two solid blue lights mean that the podium battery is between 50%-74% of its capacity; One solid blue light means that the podium is between 25%-49% of its capacity; One flashing blue light means that the podium is less than 25% of its capacity, and should be charged soon.

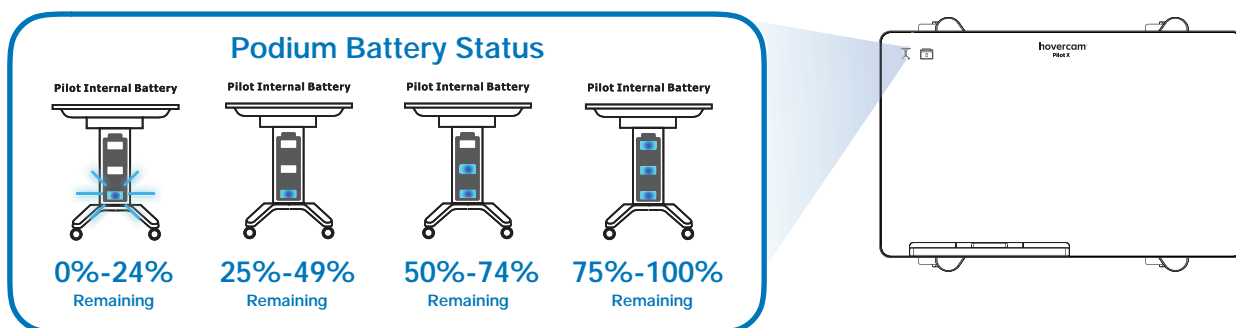

The Pilot X/S Tablet has an internal battery for wireless operation. The tablet can achieve around 3 hours of standalone use under normal operating conditions. When docked on the podium, the tablet can achieve around 6 hours of use under normal operating conditions. To conserve battery life, make sure the document camera is folded away when not in use (Page 17).

There are three methods to charge the Pilot X/S Tablet:

1 Charging on the Tablet Dock

The simplest and most common way to charge the tablet is via the **Magnetic Tablet Dock**, located on the lower left corner of the **Podium Surface**. The dock also connects the tablet to the podium's **Retractable Keyboard** and the **Podium Audio Line In/Out**.

To charge the tablet on the **Magnetic Tablet Dock**, first make sure the podium battery has a charge, otherwise the podium will need to be plugged into an A/C outlet via the **Podium Power Adapter** (page 9). Place the tablet on the podium surface above the tablet dock, being sure to align the **Magnetic Docking Connectors**. With the connectors aligned, simply slide the tablet down along the podium surface until the magnets pull the tablet into position.

The **Tablet Charging Indicator** is located on the upper left corner of the **Podium Surface** next to the **Podium Charging Indicator**, and will flash when the tablet is receiving a charge. To see the tablet's current charge level, check the battery status on the Windows® 10 Taskbar.

There is a secondary **Tablet Charging Indicator** located on the upper left corner of the tablet face. When the tablet is receiving a charge, the **Charging Indicator Light** will flash amber. When the tablet has been fully charged, the indicator light will be solid amber.

When the tablet is docked and the podium is plugged-in, the podium's dual charging system uses passthrough charging. This means that the tablet's battery will be charged before the podium's battery. Once the tablet is fully charged, the podium's battery will start receiving a charge.

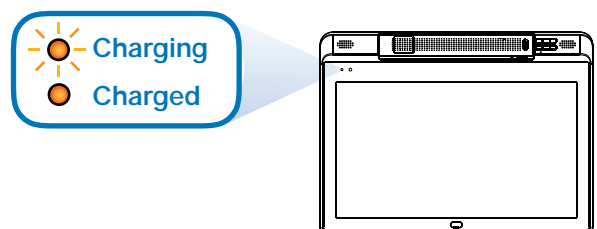
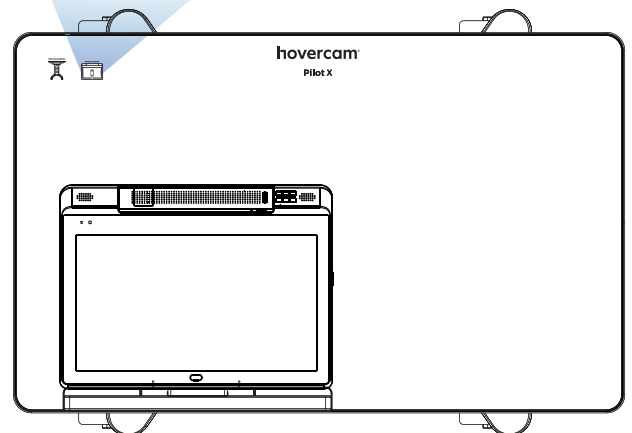
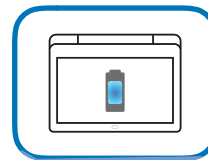
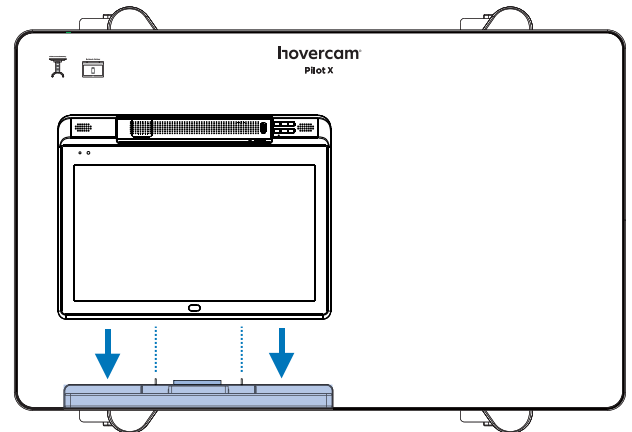

11 Charging the Tablet

2 Charging in the Tablet Storage Bay

The **Tablet Storage Bay** is a convenient and secure place to store and charge the Pilot X tablet overnight. The bay is located on the left side of the podium, and features a dropdown door that is secured by a key lock.

Follow these steps when using the **Tablet Storage Bay**:

1 Unlock the Door

The **Tablet Storage Bay Key Lock** is located on the left side of the **Podium Surface**, adjacent to the **Tablet Storage Bay**. Insert the key and rotate to disengage the lock, allowing for the bay door to be opened.

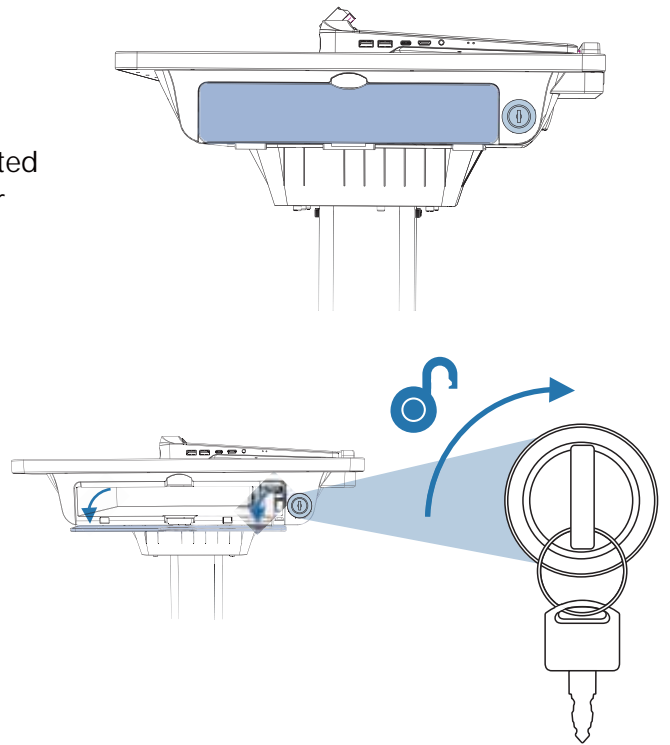



IMPORTANT!

Please make sure you make a duplicate copy of the Pilot X/S key for backup.

2 Insert the tablet

Before inserting the tablet, make sure the **Document Camera** is folded away (Page 17) and the **HoverCast Wireless Antenna** is folded down (Page 20). Orient the tablet so that the **Touchscreen** is facing upwards and the **Magnetic Docking Connector** is directly adjacent to the **Charging Actuator**, then carefully insert the tablet. When the tablet is inserted properly, you will feel the tablet click and lock into position.

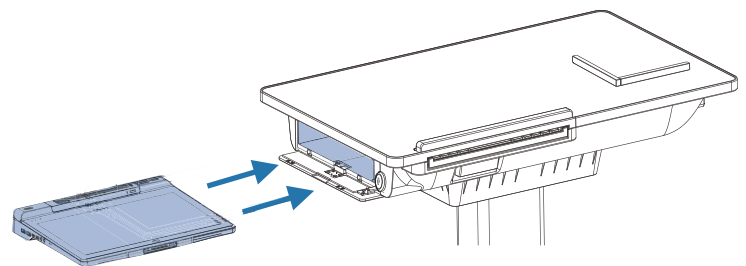

3 Lock the Tablet Storage Bay

With the tablet properly inserted into the **Tablet Storage Bay**, close the bay door, insert the key and rotate to lock the bay.

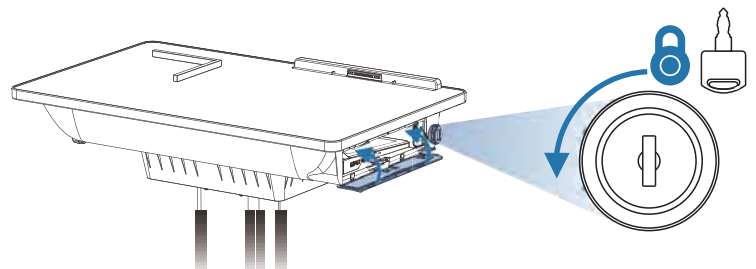

4 Activate Charging

Finally, use the **Tablet Storage Bay Charging Actuator** to enable charging by pushing-in on the lever. The charging actuator is located on the underside of the podium surface, just below the Pullout Keyboard.

The **Tablet Charging Indicator** is located on the upper left corner of the **Podium Surface** next to the **Podium Charging Indicator**, and will flash when the tablet is receiving a charge. The tablet's current battery level percentage will not be displayed on the **Tablet Charging Indicator**, and must be checked on the Windows® 10 Taskbar."

Plug the power adapter into a power outlet. Connect the power adapter cord to the Pilot X/S magnetic power port. When the power cord is plugged in, the podium's dual charging system will use passthrough charging. To charge the tablet computer, insert the tablet into the tablet bay. Once the tablet is fully charged, it will be ready for use. (We recommend charging the tablet immediately after each use.)

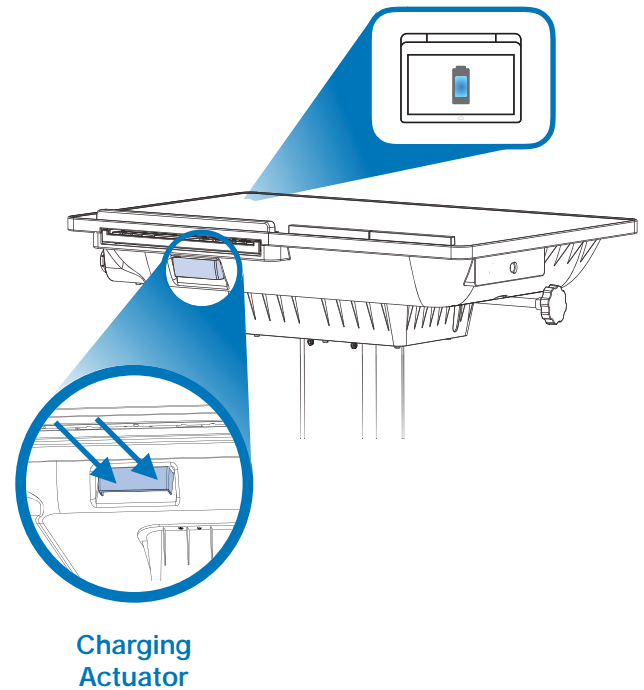

Charging Actuator

Removing the Tablet

To remove the tablet from the **Tablet Storage Bay**, you must first disengage the **Charging Actuator** by gently pulling outwards on the lever.

Finally, unlock the **Tablet Storage Bay** (see **Step 1**) and remove the tablet by pressing in on the tablet until it clicks inwards. The tablet will then release and can be gently removed from the **Tablet Storage Bay**.

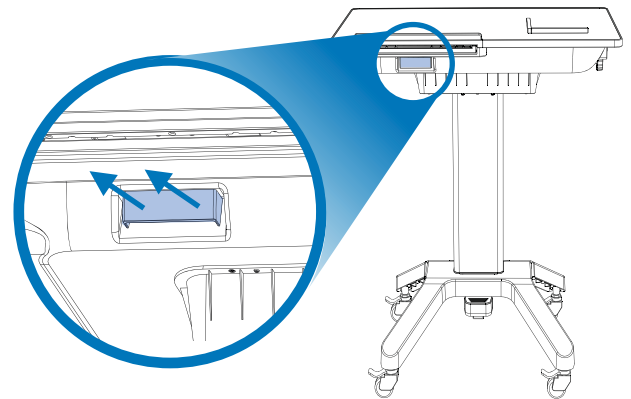

3 Charging with the Tablet Power Adapter

The tablet can also be charged independently of the podium using the included **Tablet Power Adapter**. Simply plug the power adapter into an available A/C wall outlet, and then into the tablet's USB-C port.

When the tablet is receiving a charge, the **Charging Indicator Light** will flash amber. When the tablet has been fully charged, the indicator light will remain solid amber.

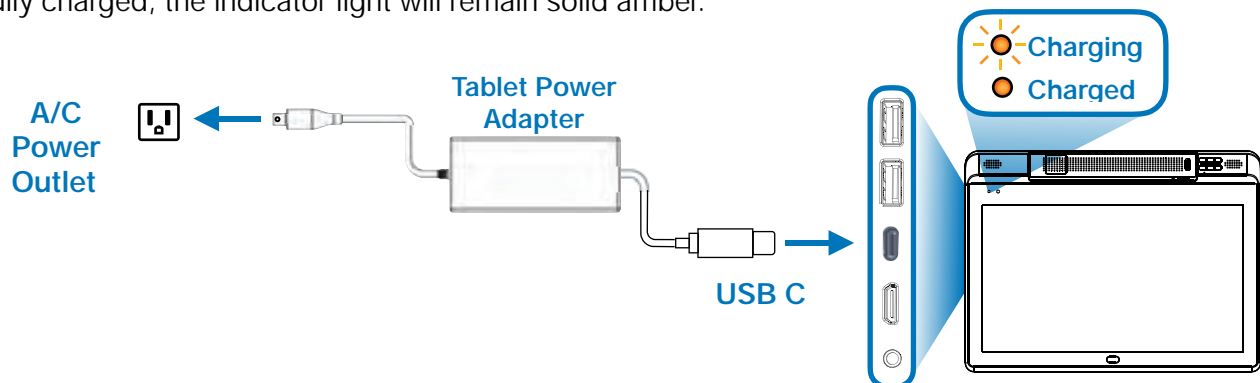

13 Operating the Tablet

Powering-On

To power-on the Pilot X/S Tablet, press and hold the **Sleep/Wake Button** for approximately 3 seconds, and the HoverCam Pilot X/S boot-up screen will appear. If the tablet does not power-on, ensure that the battery is charged or receiving a charge.

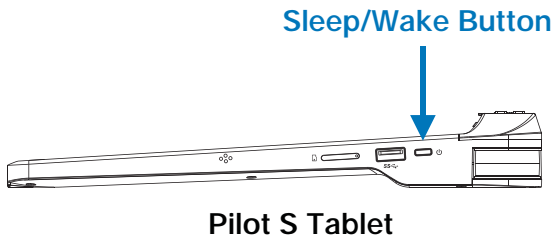
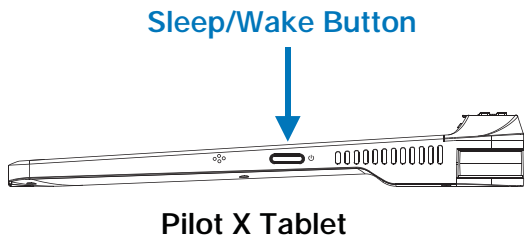

Operating the Touchscreen

The Pilot X/S tablet is equipped with a 13.3 inch capacitive multitouch screen. The capacitive technology responds to inputs from electrically charged objects, such as fingertips and active styluses, and is not pressure sensitive. **Because of this, avoid pressing too firmly on the touchscreen, as this could cause damage.**

The touchscreen is multitouch-enabled, allowing the user to scroll, zoom, swipe and more by using two or more fingers. For more information about touch gestures, visit the Windows® 10 Support page at www.support.microsoft.com/windows.

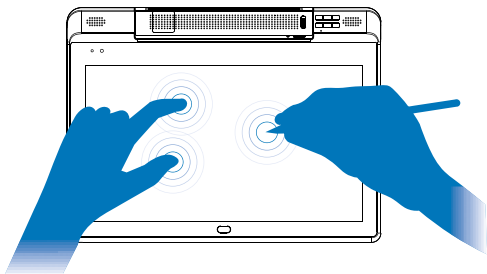

Using the Active Stylus

Pilot X/S also includes an active stylus. The active stylus must be charged through its rear charging port via the included USB mini cable. Charging the stylus takes approximately 1 hour. The usage time is approximately 8-10 hours. The active technology can be switched on and on/off button show below:

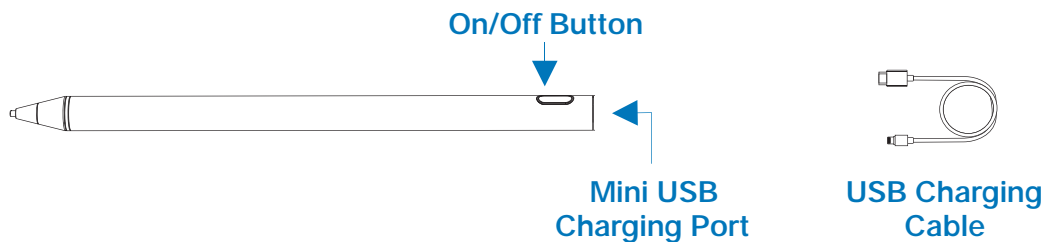

Internal PC

Pilot X/S comes fully-integrated with an internal PC. No additional computing device is required to operate Pilot X/S. See the below table for a list of key internal components and their specifications.

INTERNAL PC			
	PILOT X		PILOT S
Part Number	Pilot X: HCPX-I5	Pilot X: HCPX-I7	Pilot S: HCPS
Processor	10th Gen. Intel® Core™ i5-1020Y Processor	10th Gen. Intel® Core™ i7-1020Y Processor	Qualcomm SC8180XP 2.46GHz Processor
Operating System	Microsoft Windows 10 64-bit (license not included)		Microsoft Windows 10 ARM64 (S Mode)
Storage	256GB SSD	512GB SSD	256GB SSD UFS 2.1
Memory	8GB DDR RAM	16 GB DDR RAM	8GB LPDDR4x RAM
Display Adapter	Intel® UHD Graphics		Adreno 680
CONNECTIVITY			
Wireless HDMI	4K@30fps - 60 ft range (line of sight)		
Ports	USB 3.0 Type-A (x2), USB 3.0 Type-C (1x), USB Touch (x1), USB 3.0 Type-C (charge only) (1x), HDMI out (x1), Power in (1x), Audio/Headphone/Line out/Mic in (1x, 3.5 mm)		USB 3.0 Type-A (x2), USB 3.0 Type-C (1x), USB Touch (x1), TF Card Slot Maximum 512 gb (x1), HDMI out (x1), Power in (1x), Audio/Headphone/Line out/Mic in (1x, 3.5 mm)
Bluetooth	5.2		5.0
WiFi	Intel® WiFi 6 AX201 ax/ac/a/b/g/n		WiFi 802.11 ac/a/b/g/n/

Windows® 10

Once powered-on, Pilot X/S will operate the latest non-licensed version of Windows® 10. Essential functions, settings, operations and commands are comparable to that of a new Windows® operating desktop including interface and system presets. A Windows® license is not included, so a license key will be needed to unlock Windows® 10's full capabilities. You do not have to activate Windows® 10 for standard operations, but the system will be subject to the following limitations:

- An Activate Windows® watermark on the lower right-hand corner of the display.
- Personalization options will be inaccessible (wallpaper, accent colors, lock screen, themes, etc).

For more information on how to use your Windows® 10 operating system, see the full manual at www.support.microsoft.com/windows

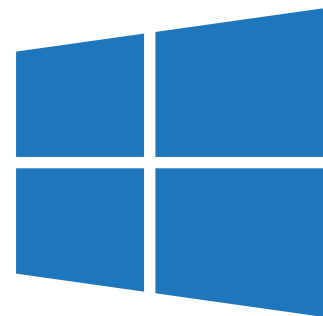

Windows 10

Imaging / Formatting

Due to the complexity of installed drivers, HoverCam offers a free imaging service. HoverCam is not responsible for damages caused by unauthorized reformatting. For more information on the free imaging service, please contact HoverCam Technical Support: support@thehovercam.com

An ethernet cable can be connected via a dongle (not included) to one of Pilot X/S's **USB ports** (Type-A or Type-C) to facilitate imaging and wired networking. Note: When reformatting Pilot X/S, the reinstallation of specific drivers may be required. For convenience, the Pilot's required drivers are also preloaded on the included **USB Drive** and can be reinstalled after imaging.

Tablet Mode

For users who want a more touch-friendly experience, Pilot X/S can be configured to activate tablet mode when removed from the **Magnetic Tablet Dock**. While in tablet mode, apps will open in full screen, the start menu will replace the desktop, icon sizes will increase, etc. Tablet mode can also be manually switched on or off within the action center on the taskbar. For more information on tablet mode, visit the Windows® 10 Support Page at www.support.microsoft.com/windows.

Desktop Mode

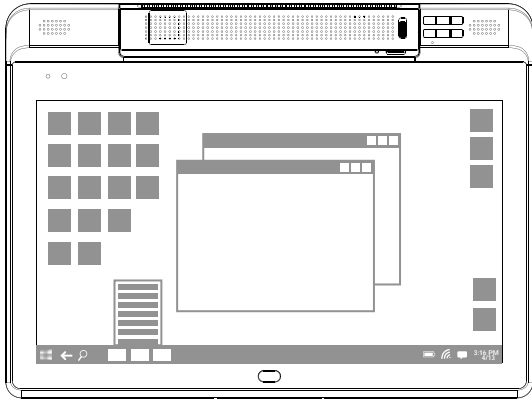

Tablet Mode

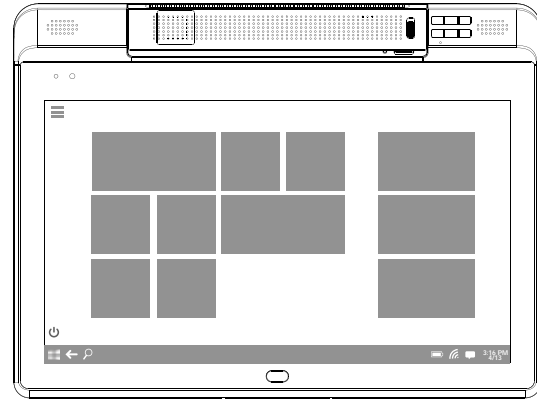

Thumb Strap

For added safety, an optional **Thumb Strap** is included with every Pilot X/S Tablet. The thumb strap allows the user to maintain a better grip on the tablet while using it independent of the podium.

WARNING: The thumb strap is *not* designed to support the full weight of the Pilot X/S tablet. Always keep two hands on the tablet, and never carry it by the thumb strap alone. Damages caused by negligent use of the thumb strap will not be covered by the factory warranty.

To install the thumb strap, first remove the adhesive film and position the strap horizontally below the underside lip as pictured below, making sure to align the 2x 10mm screw holes on the back of the tablet casing. Then use a small Phillips screw driver (not included) to secure the 2x included 10mm screws into position.

Thumb Strap Positioning

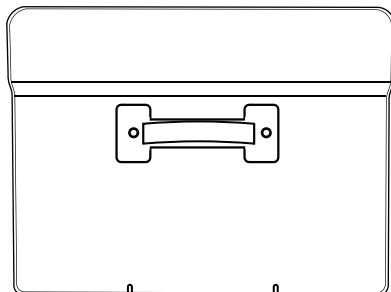

Proper Use of Thumb Strap

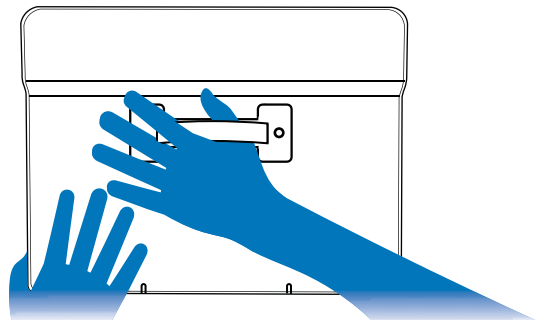

Using the Pop-Out Keyboard

The Pilot X/S tablet will connect to the podium's **Pop-Out Keyboard** when docked on the **Magnetic Tablet Dock**. To deploy the keyboard, simply push-in on its front edge and it will automatically extend. To retract, gently push it back into the unit until it locks into place.

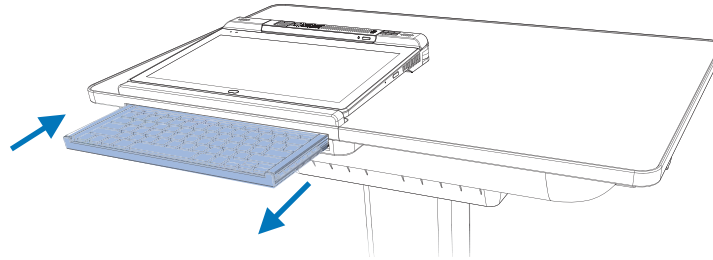

Using the Digital Keyboard

When using the tablet independent of the **Magnetic Tablet Dock**, the digital keyboard must be used for any typing input. To access the digital keyboard, simply click on the digital keyboard icon on the right side of the Windows® taskbar. If the icon is missing, you'll need to access typing settings to enable it (Windows® Settings → Devices → Typing). For more information on the digital keyboard, visit the Windows® 10 Support page at www.support.microsoft.com/windows.

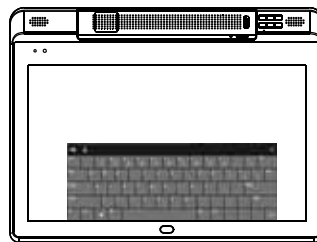

Using Third Party Accessories

Most USB third party accessories that work with standard PC's will work with the Pilot X/S. This includes mice, keyboards, flash-drives, etc. Plug the accessory into one of the two **USB 3.0 Type-A** ports located on the left side of the **Pilot X/S Tablet**. Bluetooth devices, such as a bluetooth mouse, can also be connected to the Pilot X/S. For help connecting **bluetooth** enabled devices, visit the Windows® 10 Support Page at www.support.microsoft.com/windows.

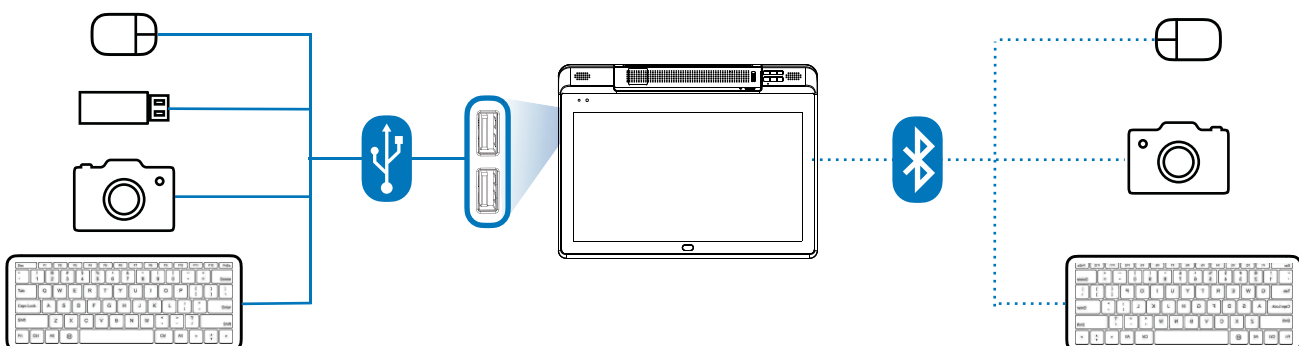

17 Document Camera

The Pilot X/S tablet comes equipped with a **Fold-Out Document Camera**. The document camera can be used as a lesson recorder, scanner, webcam, live annotation tool, microscope, show-and-tell device, audio recorder, video logger, and much more. For optimal functionality, use the included Flex 11 software (page 18) to operate the document camera. Camera specifications are as follows:

Camera Sensor	13.0 MegaPixel BSI CMOS	Zoom	480x (6x ASR, 8x Digital, 10x Mechanical)
Video Resolution	4K@30FPS, 1080p @60FPS, 720p @120FPS	Audio	Built-in High-Fidelity Microphone
Image Resolution	4224x3156 (13 MP)	Focus	AutoFocus, Selective Focus, Focus Lock
Scan Size	US Letter & US Legal	Lighting	Integrated LED

Deploying

To deploy the document camera, push-down on the **Document Camera Release Button** (a silver circular hinge found on top of the tablet), and the camera arm should release with a “click”. The camera arm can now be rotated out of its recess. Once deployed, the system will detect that the camera is in use, and it will be discoverable as a USB device. The camera arm has three moving sections: the **Post**, **Head** and **Base**.

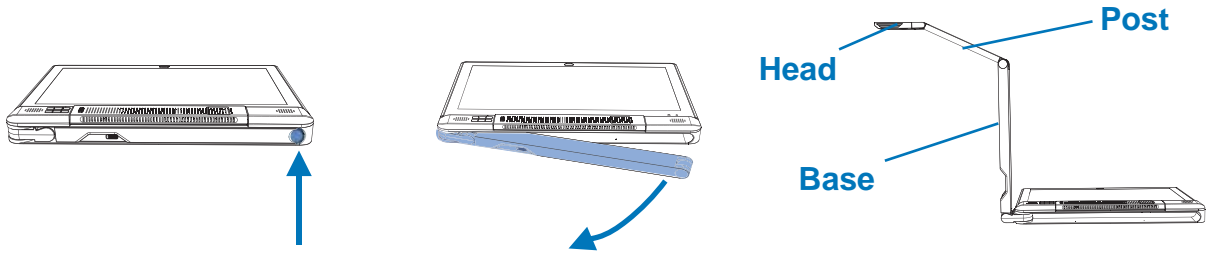

To close the document camera, simply fold the head and post back into the base, and rotate the base back into the recess until it “clicks” into place. The system will know that the camera has been folded away, and disconnect it to conserve battery.

Positioning

Once deployed, the base can pivot outwards 180°, and can tilt up or down 180°. The post folds out of the base, and adds an additional 180° range of upward/downward tilt. The head also tilts up or down 180°, and can pivot 270°. When on a flat surface, the camera’s viewable area can easily show full letter and legal sized pages when the camera arm is positioned properly.

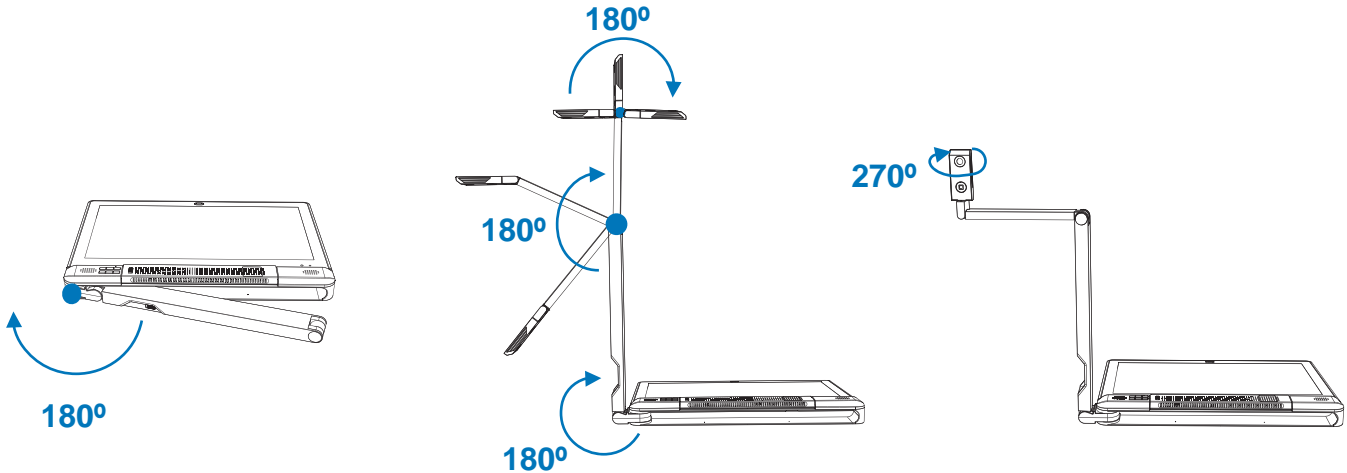

Software

The tablet comes with two document camera software programs preinstalled: **Flex 11**. Questions? Contact HoverCam Technical support for more information at <http://www.hovercam.com/support>.



Flex 11 is a dedicated document camera software for live lesson presentation and annotation, video recording, still image capture, document scanning, digital whiteboarding and much more. Note: Flex Whiteboard may be installed as a separate program.

For the full software downloads, updates and training visit:

<https://www.hovercam.com/flex11>

Operating

Operating the document camera is easy with the onboard **Document Camera Controls**, found on the top right corner of the **Pilot X/S Tablet**:

- **Zoom-In:** Zooms in on the camera's view area.
- **Zoom-Out:** Zooms-out of the camera's view area.
- **Autofocus:** Enables automatic focusing on the dominate object in the camera's view area. Periodically readjusts focal point to keep the dominate object in focus.
- **Autofocus Lock:** Fixes the focal point on the most dominate object in the camera's view area, and retains that focal point until deactivated.
- **Camera Reset:** Resets the camera's main board when an error occurs. Use a small object, such as the tip of a paper clip.
- **Rotate:** Rotates the camera's image 180°.
- **Freeze:** Freezes/unfreezes the camera's image.

Please note that the **Document Camera Controls** may not be compatible with 3rd party softwares, and are designed to work best with the included **Flex 11** software program.

The document camera also features an **LED Light** for added illumination in darker areas. Toggle the **Illumination Switch** found on the **Camera Head** to activate or deactivate the LED Light.

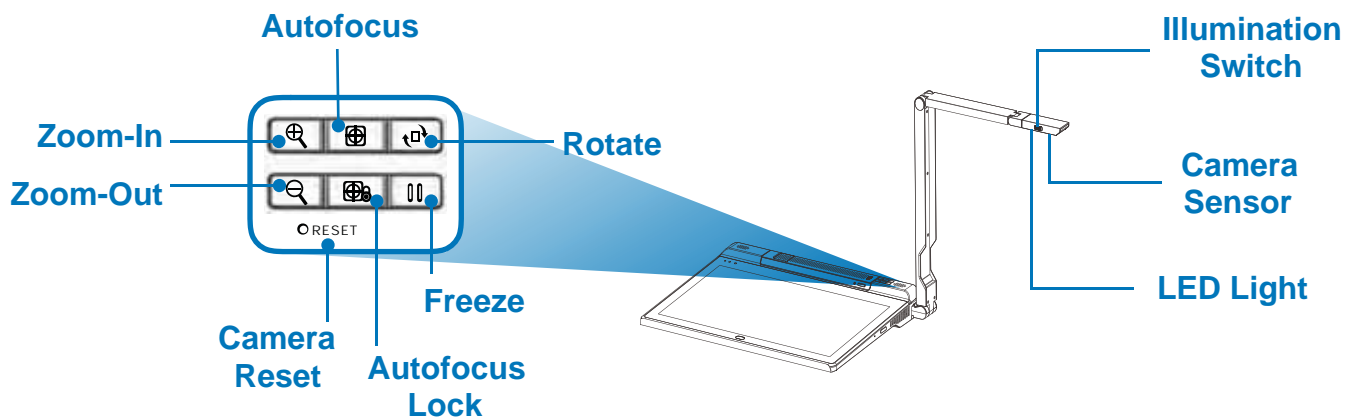

19 Connecting to a Display: HoverCast

HoverCast Wireless HDMI

Pilot X/S comes equipped with state-of-the-art wireless interactive casting technology called HoverCast. Using the **HoverCast Receiver**, Pilot X is capable of casting a high definition HDMI image to any interactive flat panel, projector or other output display with an HDMI input. Unlike other wireless casting technologies, HoverCast has virtually no loss in image clarity and no noticeable delay. It does not use a WiFi network or interfere with local WiFi networks.

When used with a **Touch-USB** enabled display (supported by most "interactive" panels and projectors), HoverCast also sends the user's touch inputs from the display back to the tablet. This allows the user to control their tablet from the display.

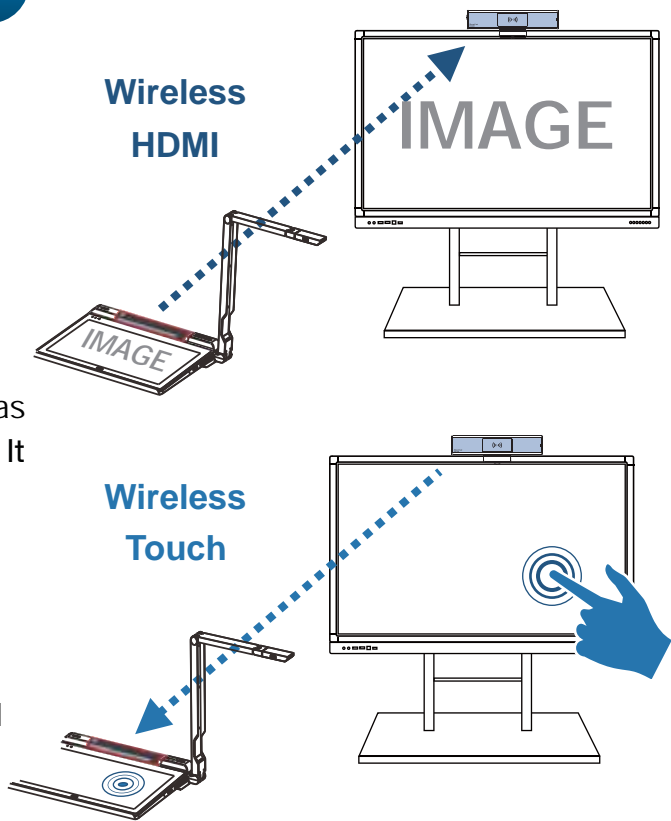

How Does HoverCast Work?

HoverCast is composed of two main components: the **HoverCast Wireless Antenna** (preinstalled on the **Pilot X/S Tablet**) and the **HoverCast Wireless Receiver** (an accessory to be plugged into the intended display). The Antenna and Receiver are pre-paired one-to-one out of the box, so they will connect automatically when set-up properly. There is no software to install or passwords to enter.

HoverCast Wireless Antenna

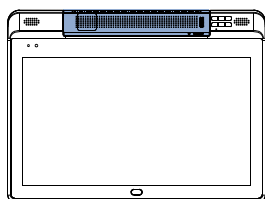

HoverCast Wireless Receiver



The HoverCast wireless signal travels similarly to a beam of light. Light doesn't pass through walls, so neither will the HoverCast signal. **HoverCast will only work when the HoverCast Wireless Antenna and HoverCast Wireless Receiver are used in the same room.**

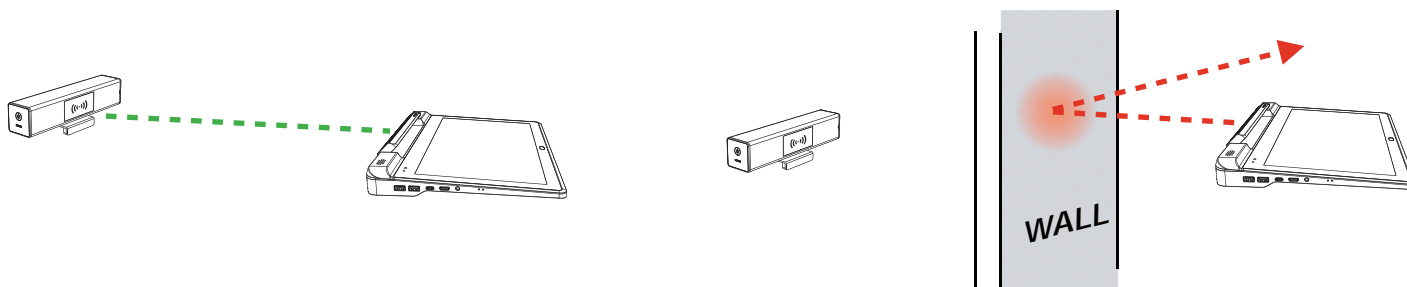

HoverCast works best when the tablet's **HoverCast Wireless Antenna** is *directly facing* the **HoverCast Wireless Receiver** (which will be placed near the output display). For boosted reception, you can angle the tablet's **HoverCast Wireless Antenna** forwards by 20°. Increasing the tilt angle of the radio signal can potentially increase signal strength. When unobstructed, the tested range for the HoverCast receiver is over 100 feet.

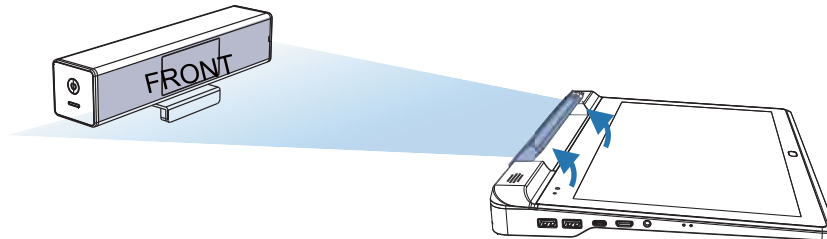

The tablet's **HoverCast Wireless Antenna** and the included **HoverCast Wireless Receiver** each contain an array of antennas facing multiple directions to increase the likelihood of a successful connection. This allows the signal to occasionally bounce off of walls and eventually form a steady signal. However, **completely blocking line of sight between the antenna and receiver will interrupt the signal.**

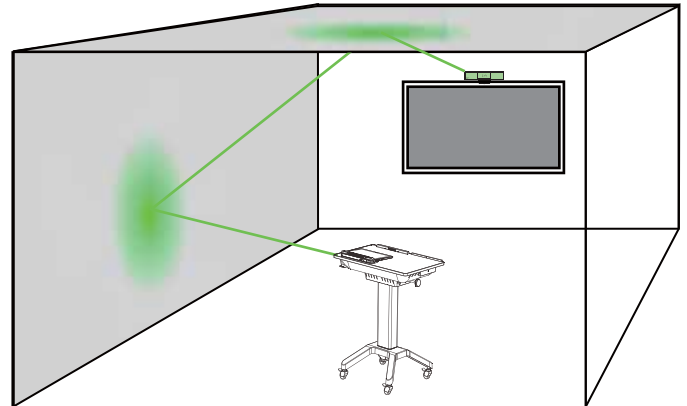

Do not position any large solid objects between the antenna and receiver that can completely cut off transmission. Do not stand too closely in front of the antenna or receiver. Do not crowd or completely block the antenna or receiver with your hands, books, or other objects that can completely cut off line of sight.

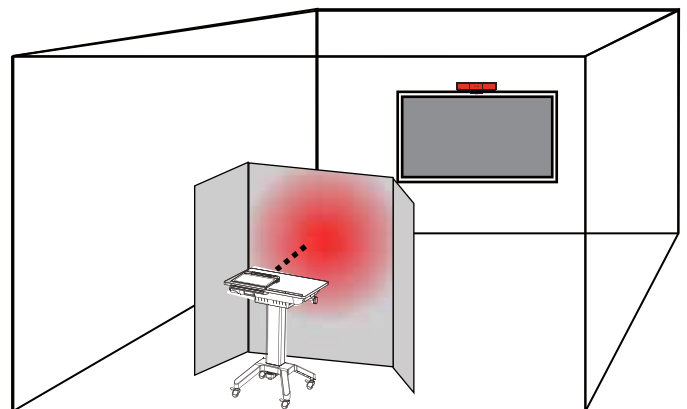

For the do's and don'ts of positioning the HoverCast system, see the HoverCast Positioning Diagram on pages 23, 24 and 25

HoverCast Set-Up

While there is no software to set up or passwords to enter, the right steps must be followed in the set-up process to enjoy the benefits of wireless HoverCast technology.

1 Install the Receiver: Install the **HoverCast Wireless Receiver** on or near the intended output display by hand-tightening the retention nut clockwise until the the unit is secure. The receiver can also be placed near a projector, AV console, or other output interface, as long as it retains line-of-sight of the tablet's **HoverCast Wireless Antenna**. For a visual reference, please see the **HoverCast Positioning Diagram** on pages 23, 24 and 25.

2 Connect HDMI: Find an available HDMI-In port on the output display's interface panel, and connect the **HoverCast Wireless Receiver** via the included **HDMI Cable**.

3 Connect Touch-USB (optional): If you are using a Touch-USB enabled display, find an available Touch-USB port on the output display's interface panel, and connect it to the **HoverCast Wireless Receiver** via the included **Type-A or Type B USB 2.0 Cable**, depending on the panel's interface type. If output display's interface panel has multiple Touch-USB inputs, be sure to use the Touch-USB port number that corresponds with the HDMI-In number that is being used. (Example: If you are using the *HDMI 2* input, also use the *Touch-USB 2* input).

4 Supply Power to the Receiver: Locate an available A/C wall outlet, and connect the **HoverCast Wireless Receiver** with the included **HoverCast Power Adapter**. When properly powered, the receiver will display a single red solid light.

HoverCast Wireless Receiver (Back)

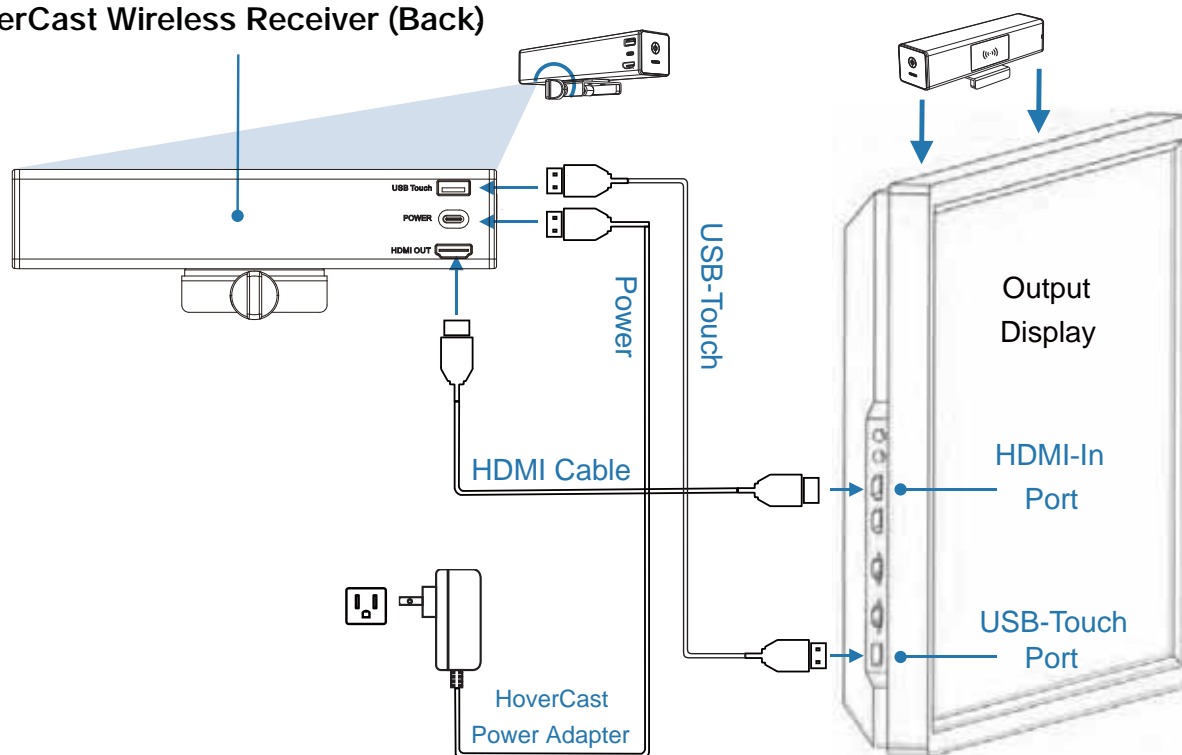

5 Switch on the **Pilot X/S Tablet** via the **Tablet Sleep/Wake Button** and switch on your output display, making sure the corresponding HDMI input is selected. Next, **plug the power line in** to turn on HoverCast. The **HoverCast Wireless Receiver's** indicator lights will begin a rapid flashing sequence until a connection is formed. **When all indicator lights are solid blue, the pairing is complete** and the systems is ready for wireless use.

HoverCast FAQ's

- *Do I need to turn off the **HoverCast Wireless Receiver** when I'm done using it?*
No. The **HoverCast Wireless Receiver** is equipped with a power save mode, and will automatically go to sleep when it loses a signal.
- *My HoverCast system isn't pairing. Can I pair it myself?*
The HoverCast system is pre-paired from the factory. Avoid pressing the **HoverCast Reset Button** or the **HDMI / Touch Reset Buttons**, as this will unpair the units. Please contact HoverCam Technical Support for HoverCast troubleshooting.
- *Does HoverCast require WiFi?*
No. HoverCast doesn't require a WiFi or internet connection to function. However, bluetooth technology is used for wireless touch-USB.
- *Can I turn off my **Pilot X/S Tablet's** Bluetooth?*
Wireless USB-Touch connects via a bluetooth network. Do not turn-off the **Pilot X/S Tablet's** bluetooth functionality, or remove "CS-MTouch" device from the bluetooth connections list.
- *Do I need an interactive display to use HoverCast?*
No. Simply skip Step 4 for wireless HDMI-only operation.
- *Is my interactive display compatible with wireless USB-Touch?*
HoverCast supports wireless USB-Touch with many (but not all) interactive flat panels and interactive projectors. Contact HoverCam Technical Support with compatibility questions.

HoverCast Troubleshooting

If you are having issues connecting the HoverCast system, please contact HoverCam Technical Support:

HoverCam Technical Support
support@thehovercam.com
+1 (866) 201-2056

✓ The HoverCast Wireless Receiver's front must face outwards, towards the receiver and away from any walls or cavities.

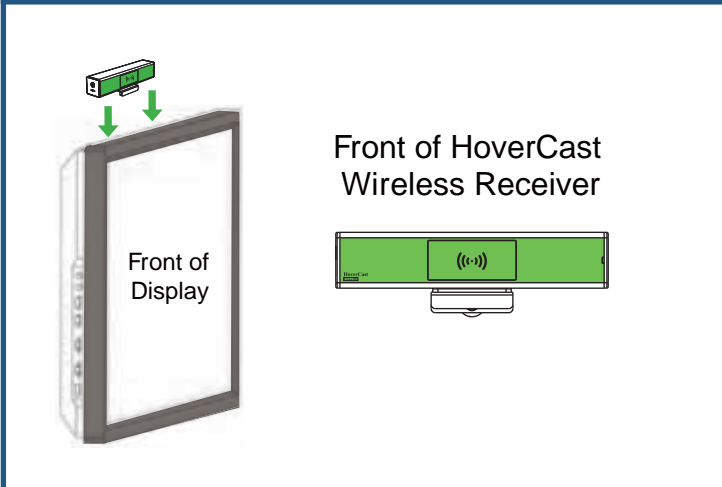

✗ Make sure the HoverCast Wireless receiver is not mounted backwards. The front of the receiver should face wherever the tablet will be used most frequently.

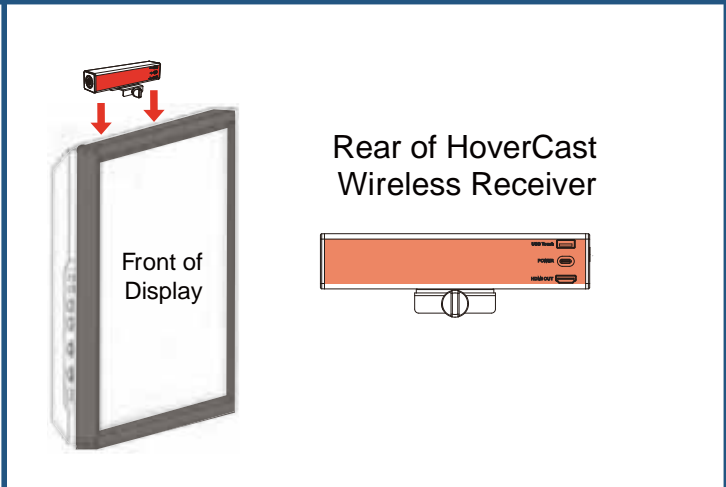

✓ The HoverCast signal is strongest when the antenna and receiver maintain line-of-sight. The maximum tested range is 100 feet.

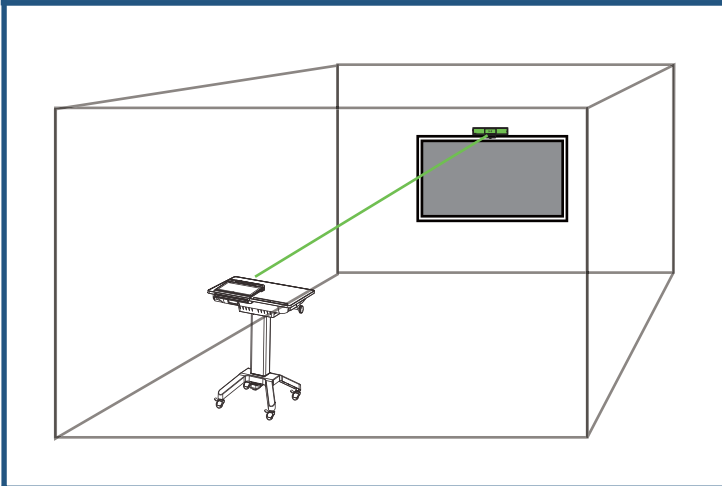

✗ The HoverCast signal can be blocked by obstructing objects. Make sure the antenna and receiver maintain line-of-sight.

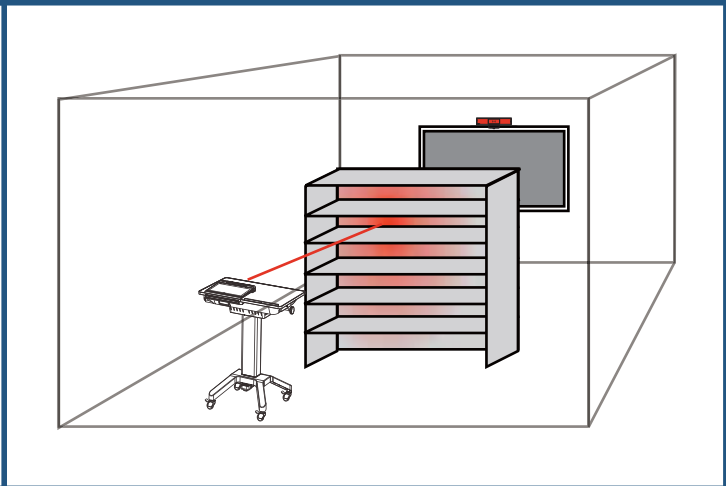

✓ In some environments (like enclosed rooms with little obstructions), the antenna can face away from the receiver and the HoverCast signal can bounce off walls and connect to the HoverCast receiver.

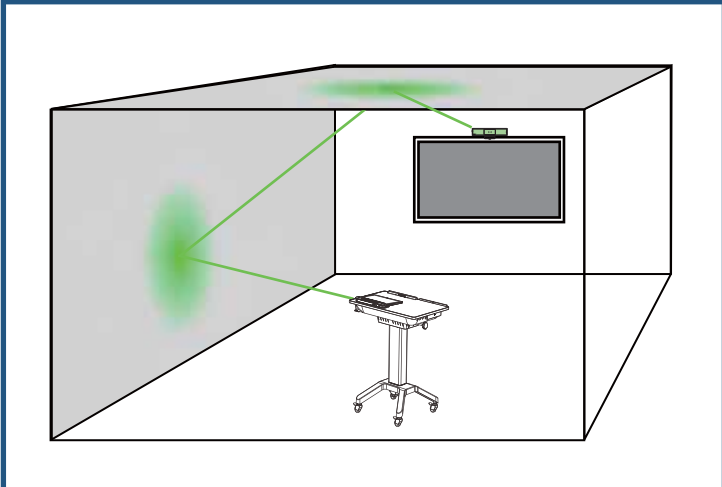

✗ The HoverCast signal can pass through windows. Avoid facing the HoverCast antenna towards windows, and opt for line-of-sight positioning.

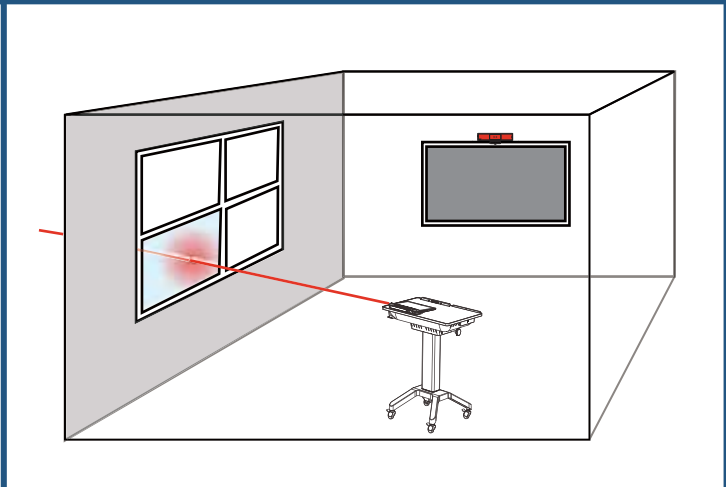



Be sure to mount the HoverCast Wireless Receiver facing away from walls, and in plain sight.

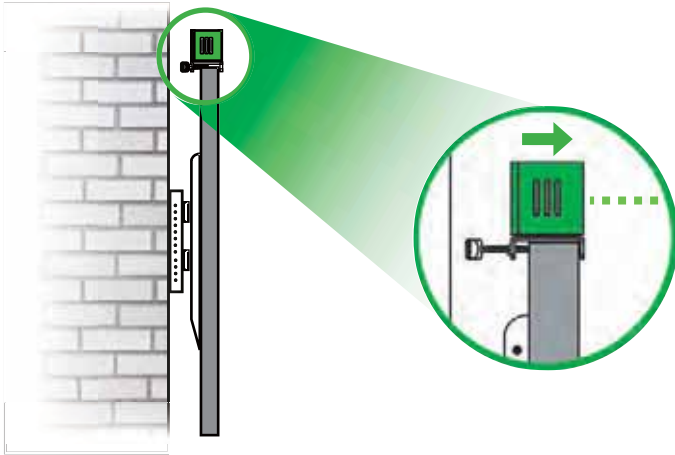

Do not tuck the HoverCast Wireless Receiver behind panels or in other enclosed spaces. The receiver should be mounted high and within line-of-sight of the antenna.

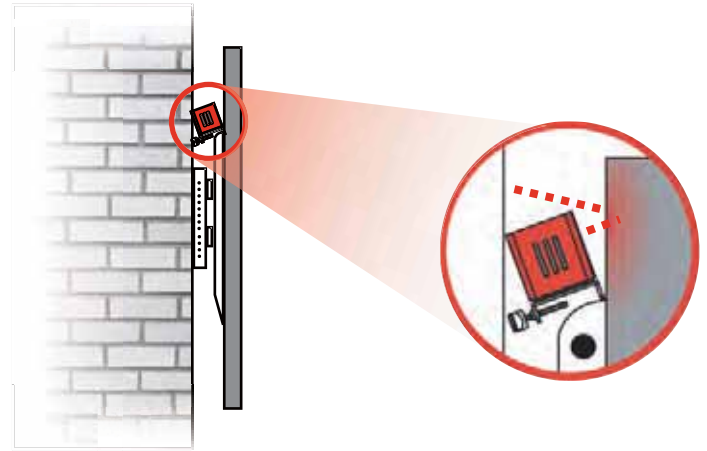

When using with a ceiling-mounted projector, make sure the front of the HoverCast Wireless Receiver is directed downward towards the antenna. Use zip-ties or adhesive to secure the receiver to the underside of mounted projectors.

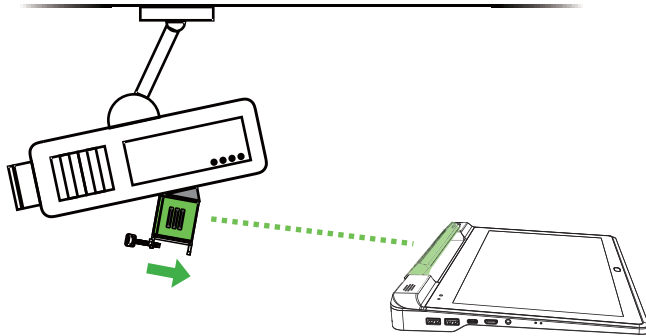

Do not place the HoverCast Wireless Receiver facing towards the ceiling when mounting on a projector. Adjust the receiver placement so that it faces downward.

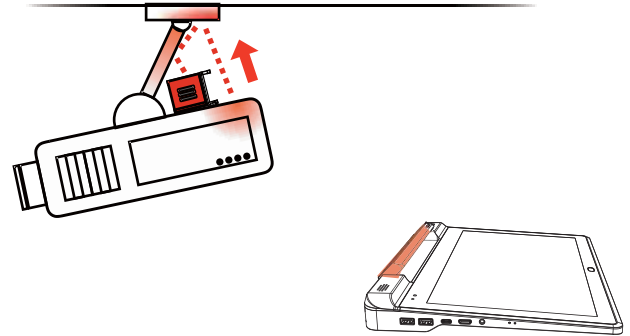

While placing the HoverCast Wireless Receiver in low places isn't ideal, it still must be placed within line-of-sight of the antenna when doing so.

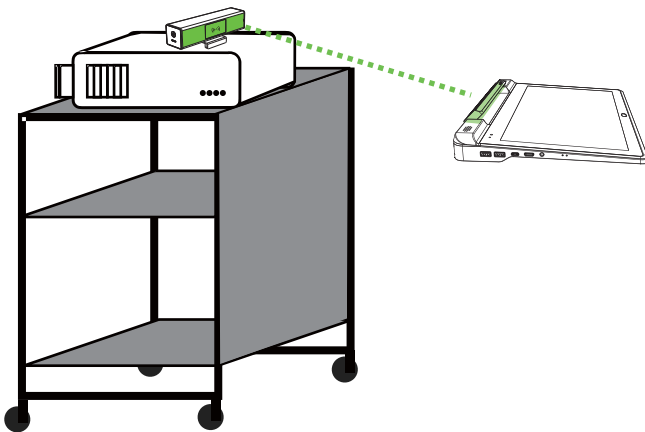

Do not place the HoverCast Wireless Receiver in enclosed spaces like cabinets or walled A/V carts. Always make sure the receiver is placed as high as possible so that it maintains uninterrupted line of sight with the antenna.

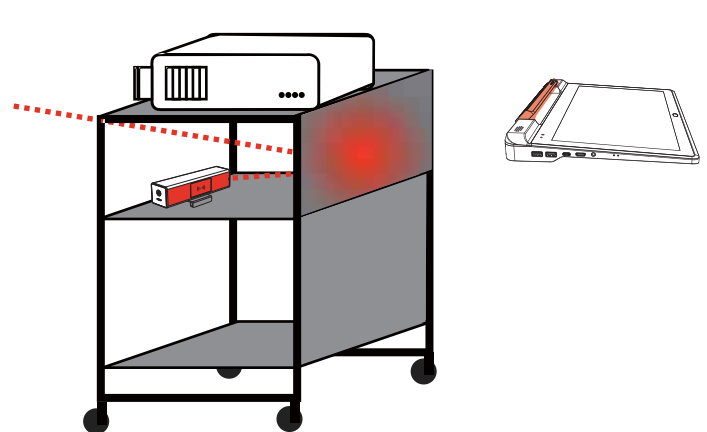

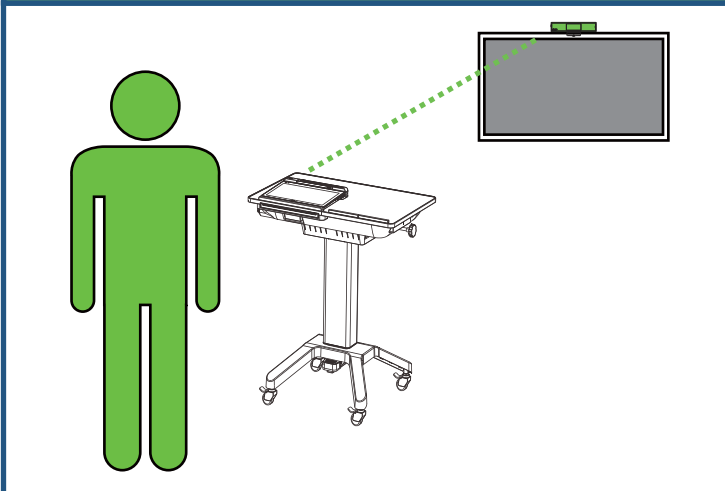
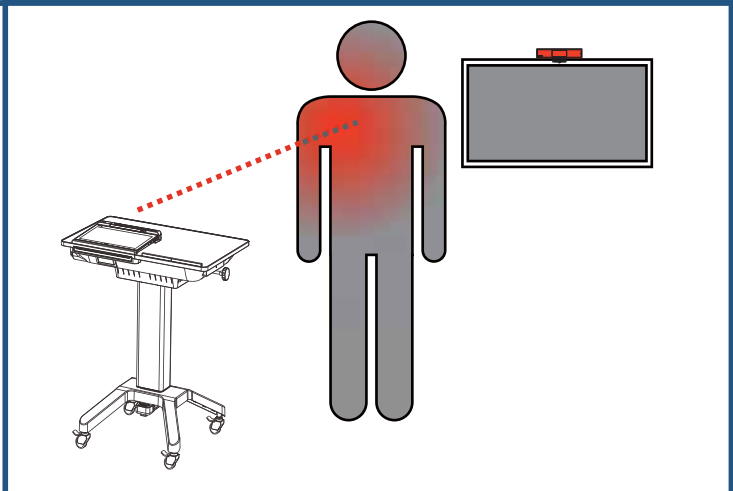
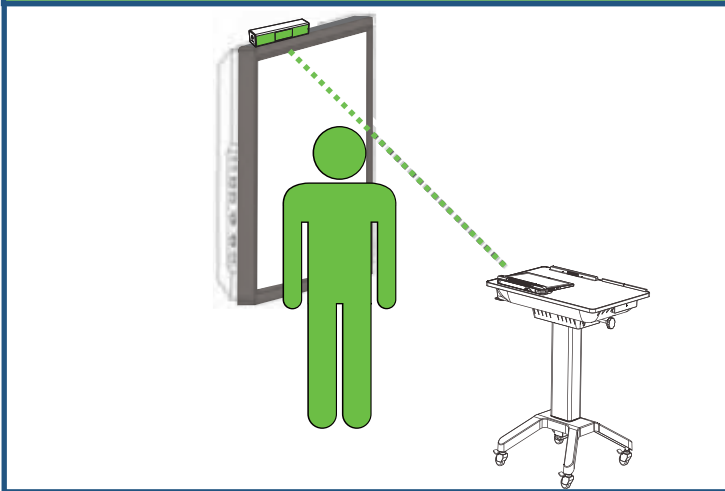
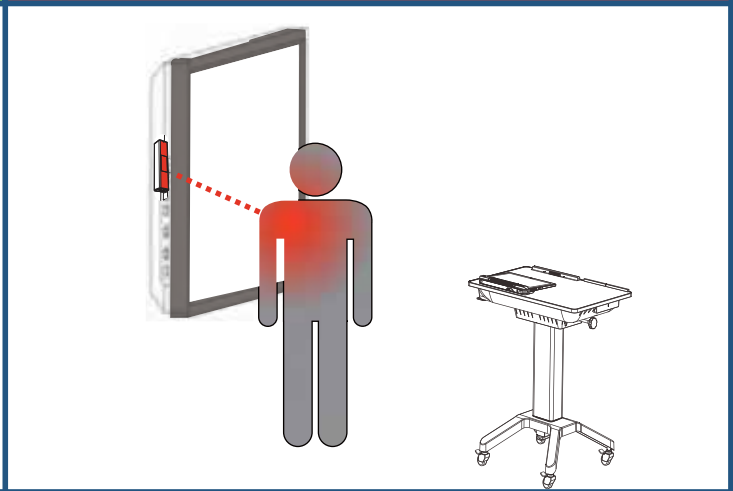
<p>✓ Standing behind the Tablet's HoverCast Wireless Antenna will allow for maximum line of sight with the HoverCast Wireless Receiver.</p>	<p>✗ Standing in front of the Tablet's HoverCast Wireless Antenna can cause signal-drop. Do not stand between antenna and receiver.</p>
	
<p>✓ Mount the HoverCast Wireless Receiver as high as possible to maximize line of sight and minimize chances of signal interruption.</p>	<p>✗ Do not mount the HoverCast Wireless Receiver on the sides of a panel, as the low mount-height can lead to signal interruptions.</p>
	

HoverCast Troubleshooting

If you are having issues connecting the HoverCast system, please contact HoverCam Technical Support:

HoverCam Technical Support
support@thehovercam.com
+1 (866) 201-2056

The **Pilot X/S Tablet** can output to an external display using a Type-A to Type-C (Mini) HDMI cable (not included). Simply connect the display to the Pilot X/S Tablet's **Type-C (Mini) HDMI-Out** on the left side of the Pilot with an HDCP-compatible Type-C (Mini) to Type-A HDMI cable.

When used with an interactive display, a USB 2.0 Type A cable can be used to connect the **Pilot X/S Tablet** to an interactive display's Touch-USB port.

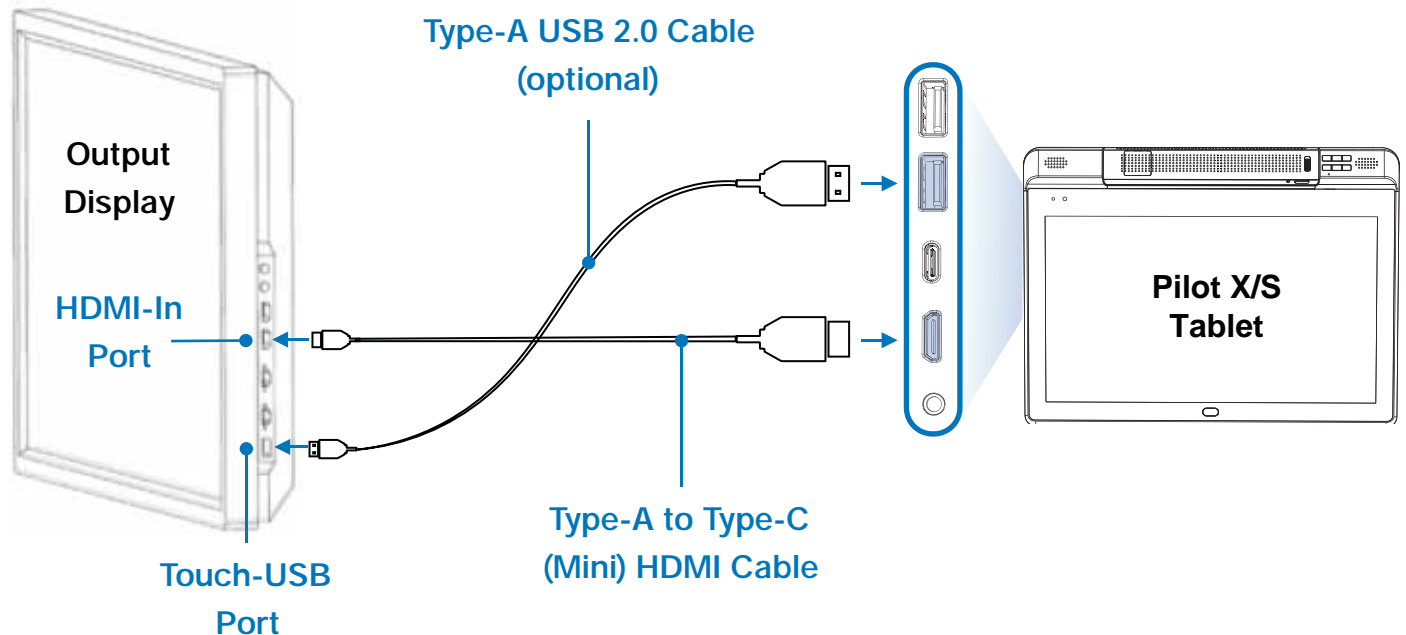

Display Mode

The **Pilot X/S Tablet**'s default output display mode is “extended display”. In extended display mode, the external display acts as an extension to the tablet's main display, showing only the windows placed in the extended area. This area can be oriented to the right, left, top, or bottom of the tablet's main display area.

You can easily switch to “duplicate display” mode, in which the external display will show the exact mirror image of what appears on the tablet's screen. To set the tablet to duplicate display mode, switch the display preferences in the Windows® display settings menu.

For detailed instructions on switching display modes, consult the Windows® 10 manual:
www.windows10-guide.com

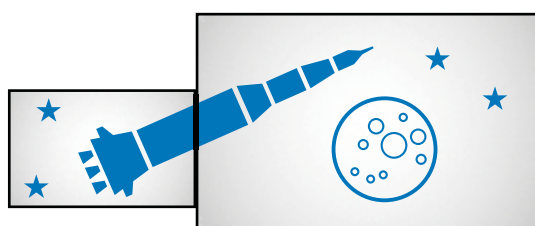

Extended Display Mode

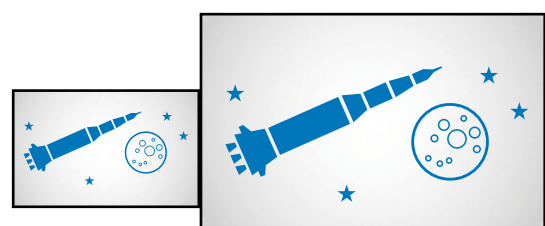

Duplicate Display Mode

There are several options for outputting audio from the **Pilot X/S Tablet**

Built-In Speakers (default)

By default, the **Pilot X/S Tablet** outputs audio through its internal speakers. In the Windows® playback device list, the tablet's internal speakers should be listed as "Realtek High Definition Audio."

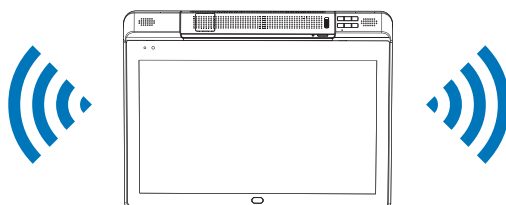

Output Display's Speakers

When using HoverCast or the HDMI-Out to connect to an external display with speakers, audio can output through the external display's speakers. Simply connect HoverCast and select the display audio output source from the Windows® playback device list. If the output source does not appear in the list of Playback Devices, unplug the HoverCast receiver from its current HDMI port and re-plug into another. Refresh the Playback Device list and reconnect.

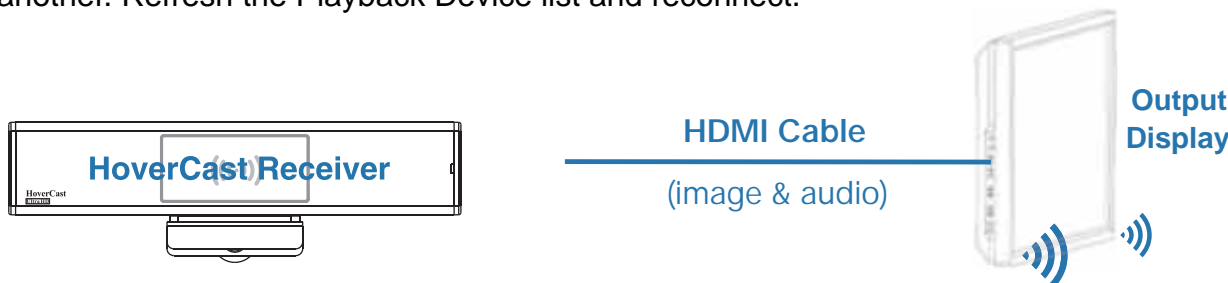

HDMI Audio De-Embedder (not included)

For use with a separate audio system, the audio signal can be separated from the HDMI signal by using a HDMI audio de-embedder and connecting it to the HDMI-Out on the HoverCast or Pilot X/S. However, many flat panel displays contain audio de-embedding technology, allowing the use of the panel's 3.5mm audio-out to output to an external audio system.

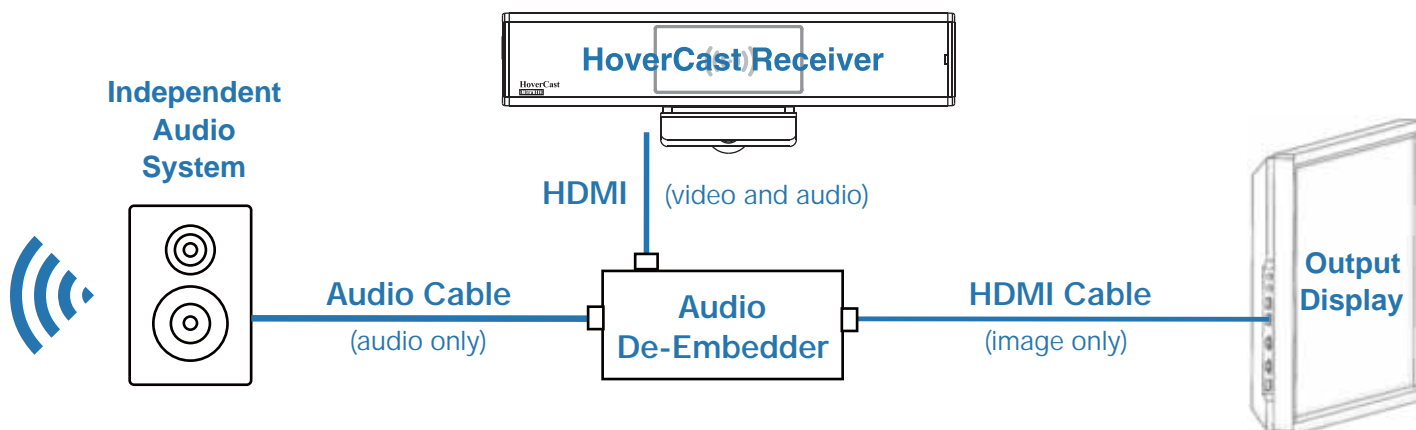

Tablet Audio Line In/Out (wired)

The **Pilot X/S Tablet** features an **Audio Line In/Out** that can be found on the left side of the tablet. Simply connect the **Pilot X/S Tablet** to an external audio system with a 3.5mm auxiliary cable.

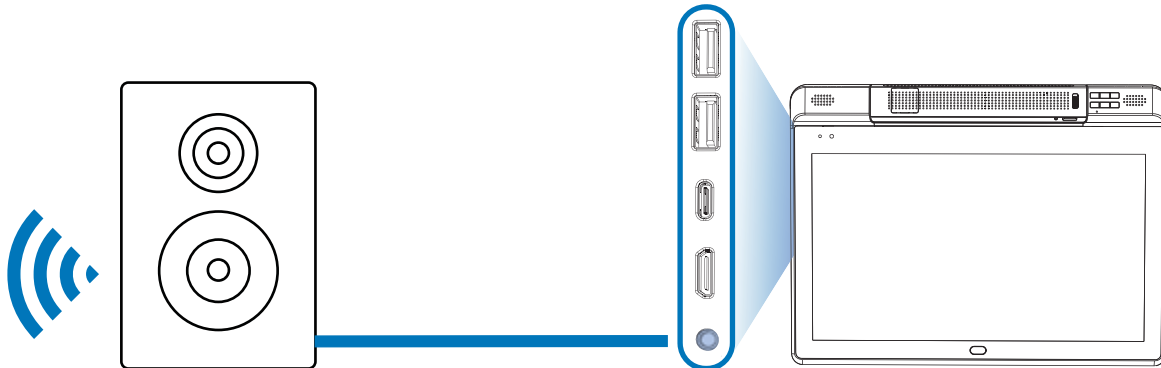

Podium Audio Line In/Out*(wired)

Some **Pilot X/S Podiums** feature an additional 3.5mm **Audio Line In/Out** that can be used when the **Pilot X/S Tablet** is placed on the **Magnetic Tablet Dock**. The Podium Audio Line In/Out can be found on the underside of the podium, and is useful when using a mounted soundbar. Simply connect the **Pilot X/S Podium** to an external audio system with a 3.5mm auxiliary cable or adapter.

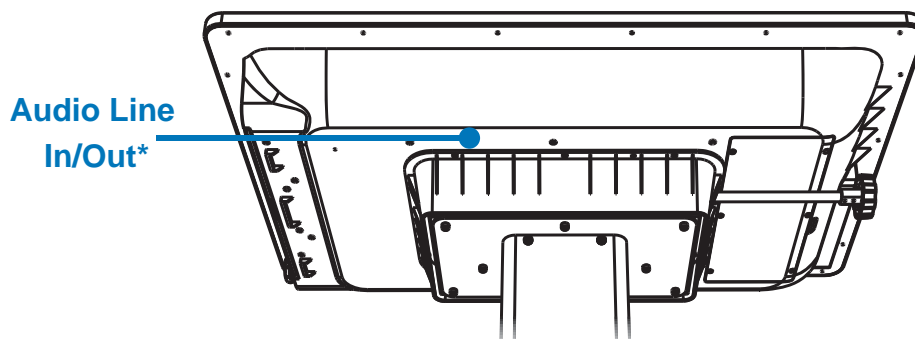

***NOTE:** The audio function has been removed on newer models of the Pilot X/S podium.

Bluetooth

The **Pilot X/S Tablet** contains a Bluetooth module that can wirelessly output to a wide variety of Bluetooth audio devices. Consult the Windows® 10 manual to learn more about connecting and configuring Bluetooth audio devices: www.windows10-guide.com

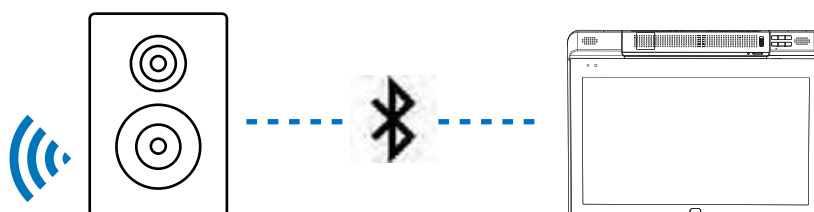

There are several options for inputting audio to the **Pilot X/S Tablet**:

Built-In Microphone (default)

The **Pilot X/S Tablet** features two internal microphones (left and right oriented) that are set as the default audio-input source. They will appear as “Realtek High Definition Audio” as an import source within Window’s settings.

For detailed instructions on connecting and selecting audio input devices, refer to the full Windows® manual: www.windows10-guide.com

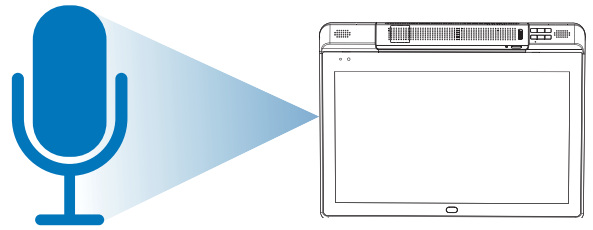

Auxiliary Microphone

The **Pilot X/S Tablet** features an **Audio Line In/Out** that can be found on the left side of the tablet. Simply connect the **Pilot X/S Tablet** to an external microphone or other audio input with a 3.5mm Auxiliary cable, and select this new source as the audio input.

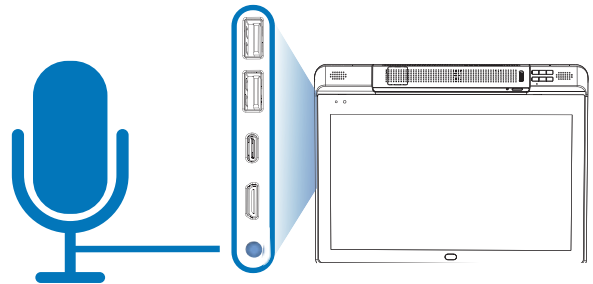

USB Microphone

A USB microphone can be used as an audio input when connected via one of the **Pilot X/S Tablet's** 2x **USB 3.0 Type-A Ports** or the single **USB 3.0 Type-C Port**. Once the USB microphone is connected, select this new source as the audio input.

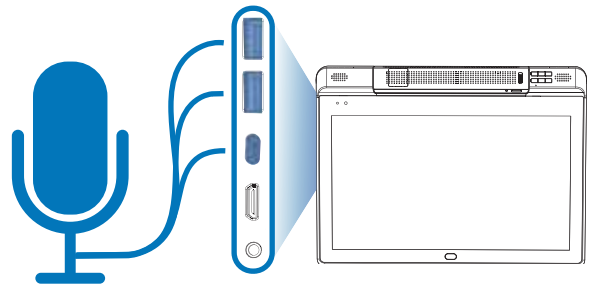

Bluetooth Microphone

A bluetooth microphone can be used as an audio input when connected from the bluetooth device menu within Windows® 10 settings. Consult the Windows® 10 manual to learn more about connecting and configuring Bluetooth audio devices: www.windows10-guide.com

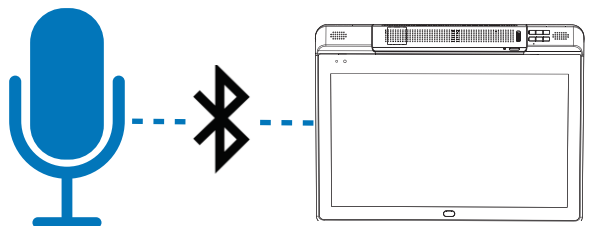

Technical Specifications

INTERNAL PC

	PILOT X		PILOT S
Part Number	Pilot X: HCPX-I5	Pilot X: HCPX-I7	Pilot S: HCPS
Processor	10th Gen. Intel® Core™ i5-1020Y Processor	10th Gen. Intel® Core™ i7-1020Y Processor	Qualcomm SC8180XP 2.46GHz Processor
Operating System	Microsoft Windows 10 64-bit (license not included)		Microsoft Windows 10 ARM64 (S Mode)
Storage	256GB SSD	512GB SSD	256GB SSD UFS 2.1
Memory	8GB DDR RAM	16GB DDR RAM	8GB LPDDR4x RAM
Display Adapter	Intel® UHD Graphics		Adreno 680

TOUCH DISPLAY

Display	13.3" LCD
Touch Panel	10-point capacitive multi-touch
Stylus Compatibility	Active stylus, Passive stylus

CONNECTIVITY

Wireless HDMI	4K@30fps - 60 ft range (line of sight)	
Ports	USB 3.0 Type-A (x2), USB 3.0 Type-C (1x), USB Touch (x1), USB 3.0 Type-C (charge only) (1x), HDMI out (x1), Power in (1x), Audio/Headphone/Line out/Mic in (1x, 3.5 mm)	USB 3.0 Type-A (x2), USB 3.0 Type-C (1x), USB Touch (x1), TF Card Slot Maximum 512 gb (x1), HDMI out (x1), Power in (1x), Audio/Headphone/Line out/Mic in (1x, 3.5 mm)
Bluetooth	5.2	5.0
WiFi	Intel® WiFi 6 AX201 ax/ac/a/b/g/n	WiFi 802.11 ac/a/b/g/n/

DOCUMENT CAMERA

Camera Sensor	13 MegaPixel BSI CMOS
Video Resolution	4K@30FPS, 1080@60FPS, 720@120FPS (WarpSpeed Video)
Image Resolution	4224x3156 (13 MegaPixels)
Zoom	x480 Total (6x adaptive sensor resolution zoom, 8x interpolated digital zoom, 10x mechanical zoom)
Scan Size	US Letter & US Legal

POWER

Power Supply	100V - 240 V, 50Hz - 60Hz
Maximum Watt	≤150W
Tablet Battery	7.4V 10000mAh Li-ion, 74WH
Podium Battery	12.6V 12000mAh Li-ion

GENERAL INFO

Tablet Storage	Tablet bay for security with key lock, storage, and charging
Keyboard and Trackpad	Yes, U.S.
Button Controls	Power on/off, menu, fingerprint scanner, HoverCast controls (on/off, reset), document camera controls (zoom-in/out, autofocus lock/unlock, rotate, freeze, illumination on/off, reset)
Podium Height Range	34" - 46"
Tilt Angle Range	0° - 20°
Shipping Weight	89.5 lbs
Software	Flex (document camera software), ClassFusion (document camera, white-boarding, lesson recording, and more)
What's in the Box	Tablet, podium, power adapter(s), magnetic anti-slip bumpers, tablet hand strap, HoverCast receiver, active stylus, USB drive, tablet bay keys (2x), assembly hardware and tools, connection cables
Certifications	FCC, CF, RoHS
Warranty	1 year standard, extended warranty and tablet insurance available

This is a preliminary guide and subject to change without notice. Depicted product appearance, features and specifications may vary in the final product(s). HoverCam® shall not be liable for technical errors or omissions contained herein. HoverCam® disclaims all responsibility and liability for the distribution and/or reliance on this user guide document. Occasionally, the manufacturer will select alternate suppliers leading to a potential change in parts and their performance, materiality, mechanics, and other variables, typically leading to increases in performance for the benefit of the user.

Cleaning and Care

When cleaning the HoverCam Pilot X/S, extra care should be given to the touch screen and external components. Glass cleaners are not advised as the moisture may damage or adversely affect touch sensitivity or component functionality. Do not directly spray any liquids (chemicals or water) onto the product. Instead, apply cleaning compounds on a dry microfiber cloth and gently clean sealed surfaces while the unit is powered off and unplugged. Avoid getting any moisture in areas where there are crevices or direct openings to the internals.

Accessing Internals

Opening the Pilot X/S tablet or podium's encasement will void any standing warranty. If you would like to access the internals to service or swap components, we strongly suggest first contacting HoverCam support.

Service and Support

Support, assembly, set-up, and troubleshooting videos are available online at the HoverCam website: www.hovercam.com/support/training-videos

For technical support and servicing requests, please contact HoverCam Technical Support:

HoverCam Technical Support
support@thehovercam.com
+1 (866) 201-2056

Limited Warranty: Subject to the terms and conditions set forth below, HoverCam (“HoverCam”) warrants the HoverCam Pilot X/S – Wireless Digital Teaching Station (“Product”), you have purchased from HoverCam or from a HoverCam authorized reseller/retailer to be free from defects in materials or workmanship under normal consumer use during the warranty period in the continental United States. If the Product becomes defective during the warranty period HoverCam will, at its option, repair or replace the Product. HoverCam may use new or reconditioned components or parts to repair the Product, or replace the Product with a new or reconditioned Product of the same or functionally equivalent model.

HoverCam Pilot X/S – Wireless Digital Teaching Station Standard Limited Warranty: Subject to the exclusions set forth below:

- One (1) year from the purchase date by the original retail purchaser (the “Customer”) (except for refurbished units which have a separate warranty policy) covers parts and labor.
- Return Merchandise Authorization Shipping: HoverCam will pay shipping freight to HoverCam or a HoverCam Authorized Service Provider and HoverCam will pay shipping freight to the Customer during the warranty period.
- DOA (Dead On Arrival): Must be reported within thirty (30) days of purchase. An RMA number must be issued in order to process the replacement. HoverCam will replace the DOA unit with a brand new replacement. HoverCam will cover the freight charges both ways.
- Shipping Damages: All shipping damages must be reported within seven (7) business days upon receipt of the Product. HoverCam is not responsible for the shipping damages reported after such period.
- Repaired or Replaced Parts and Products: All repaired or replaced parts or products shall be warranted only for the remainder of the original warranty period specified above.

Obtaining Depot Warranty Service

If you purchased a HoverCam product in the continental United States, Hawaii, and Alaska, you are entitled to depot repair service during the warranty period subject to the following terms and conditions:

1. Depot warranty service is available for all Products purchased and located in the continental United States.
2. You must contact HoverCam Technical Support Center at 1.866.201.2056.
3. HoverCam or HoverCam Technical Support Center will attempt to resolve technical issues over the phone. If telephone resolution is not possible, HoverCam or HoverCam Customer Service Center will then issue a Return Merchandise Authorization (“RMA”) number to be used as a means of identifying the product returned. RMA authorization numbers are valid for thirty (30) days and void thereafter.
4. You must return the product to HoverCam unless otherwise directed by HoverCam to a HoverCam Authorized Service Provider. HoverCam Technical Support will arrange and cover return shipping cost. You must pay any export taxes, custom duties and taxes, or any charges associated with the handling of the HoverCam product.
5. All returned Products must be accompanied with (i) the original shipping and packing materials, (ii) a description of the HoverCam product symptom and (iii) proof of the place and date of purchase. The RMA number must be clearly printed on packing slip and on the exterior shipping container. All Products must be sent in secured packaging to avoid any shipping damages.
6. HoverCam and HoverCam Authorized Service Provider reserve the right to refuse and return, freight collect, Products (i) that are not covered by HoverCam’s warranty; or (ii) for which there is no trouble found. Products delivered to HoverCam or a HoverCam Authorized Service Provider with an expired RMA may be refused and returned, without prior notice, to the Customer freight collect.
7. HoverCam or HoverCam Authorized Service Provider will use its best efforts to service Products within thirty (30) days after receipt of the Products at its warehouse facilities. For return shipments of the Products, except otherwise described herein, HoverCam or HoverCam Authorized Service Provider will pay the shipping cost and retain risk of loss until delivery to the Customer’s location as evidenced by signature collected by carrier. The Customer may designate only one location within the continental United States, Hawaii, and Alaska for return shipments. HoverCam and HoverCam Authorized Service Provider are not responsible for shipping or other delays beyond their control.

Exclusions

This limited warranty does not extend to any Product not purchased from a HoverCam authorized reseller. This limited warranty also does not extend to any product that has been damaged or rendered defective (a) due to normal wear and tear; (b) as a result of use of the Product other than for its normal intended use, or other misuse, abuse or negligence to the Product; (c) by the use of parts not manufactured or sold by HoverCam; (d) by modification of the Product; (e) as a result of service by anyone other than HoverCam or a HoverCam Authorized Service Provider; (f) improper transportation or packing when returning the Product to HoverCam or a HoverCam Authorized Service Provider; (g) improper installation of third party products; (h) improper environment (including improper temperature or humidity); (i) unusual physical or electrical stress or interference, failure or fluctuation of electrical power, lightning, static electricity, fire, or acts of God. HoverCam is not responsible for damage to or loss of any programs, data or removable storage media. You are responsible for saving (backing up) any programs, data or removable storage media.

Other Limitations

EXCEPT FOR THE WARRANTIES SET FORTH HEREIN, HOVERCAM DISCLAIMS ALL OTHER WARRANTIES, EXPRESSED OR IMPLIED OR STATUTORY, INCLUDING BUT NOT LIMITED TO THE IMPLIED WARRANTIES OF MERCHANTABILITY OR FITNESS FOR A PARTICULAR PURPOSE. ANY IMPLIED WARRANTIES THAT MAY BE IMPOSED BY APPLICABLE LAW ARE LIMITED TO THE TERMS OF THIS LIMITED WARRANTY. IN NO EVENT SHALL HOVERCAM BE LIABLE FOR ANY INDIRECT, INCIDENTAL, SPECIAL OR CONSEQUENTIAL DAMAGES OF ANY KIND, INCLUDING BUT NOT LIMITED TO LOSS OF BUSINESS, REVENUE, PROFITS, INFORMATION, DATA OR USE, WHETHER IN AN ACTION IN CONTRACT OR TORT OR BASED ON A WARRANTY, ARISING OUT OF OR IN CONNECTION WITH THE USE OR PERFORMANCE OF THE PRODUCT, EVEN IF HOVERCAM HAS BEEN ADVISED OF THE POSSIBILITY OF SUCH DAMAGES. YOU AGREE THAT REPAIR OR REPLACEMENT, AS APPLICABLE, UNDER THE WARRANTY SERVICES DESCRIBED HEREIN IS YOUR SOLE AND EXCLUSIVE REMEDY WITH RESPECT TO ANY BREACH OF THE HOVERCAM LIMITED WARRANTY SET FORTH HEREIN. IF, DESPITE THE FOREGOING LIMITATIONS, FOR ANY REASON HOVERCAM BECOMES LIABLE TO YOU FOR DAMAGES INCURRED BY YOU IN CONNECTION WITH THIS AGREEMENT, THEN, THE LIABILITY OF HOVERCAM WILL BE LIMITED TO THE AMOUNT EQUAL TO THE INVOICE AMOUNT PAID BY YOU TO HOVERCAM OR A HOVERCAM AUTHORIZED RESELLER FOR THE PRODUCT. All prices, products, terms and conditions are subject to change without notice. Some states or provinces/jurisdictions do not allow the exclusion or limitation of incidental or consequential damages for consumer products, and some states or provinces/jurisdictions do not allow limitations on how long an implied warranty lasts. In such states or provinces/jurisdictions, the exclusions or limitations of this limited warranty may not apply to you. This limited warranty gives you specific legal rights. You may also have other rights that vary from state to state/jurisdiction to jurisdiction. You are advised to consult applicable state and provincial/local laws for a full determination of your rights.

Please email HoverCam Technical Support Center to submit a support ticket:

support@hovercam.com

Hours: M-F 7:00 am – 5:30 pm PST

Phone: 866.201.2056

To avoid delays, please DO NOT SEND ANY HoverCam product to HoverCam or a HoverCam Authorized Service Provider without HoverCam's authorization.

Power Cords, Power Adapters, Extension Cables, Electrical Outlets

WARNING:

Use only the power cords and power adapters supplied by the product manufacturer.

The power cords shall be safety approved. Never wrap a power cord around a power adapter or other object. Doing so can stress the cord in ways that can cause the cord to fray, crack, or crimp. This can present a safety hazard.

Always route power cords so that they will not be walked on, tripped over, or pinched by objects.

Protect power cords and power adapters from liquids. For instance, do not leave your power cord or power adapter near sinks, tubs, toilets, or on floors that are cleaned with liquid cleansers. Liquids can cause a short circuit, particularly if the power cord or power adapter has been stressed by misuse.

Liquids also can cause gradual corrosion of power cord terminals and/or the connector terminals on a power adapter, which can eventually result in overheating.

Ensure that all power cord connectors are securely and completely plugged into receptacles.

Do not use any power adapter that shows corrosion at the ac input pins or shows signs of overheating (such as deformed plastic) at the ac input pins or anywhere on the power adapter.

Do not use any power cords where the electrical contacts on either end show signs of corrosion or overheating or where the power cord appears to have been damaged in any way.

To prevent possible overheating, do not cover power adapters with clothing or other objects when the power adapter is plugged into an electrical outlet.

Ensure that extension cords, surge protectors, uninterruptible power supplies, and power strips that you use are rated to handle the electrical requirements of the product. Never overload these devices.

If power strips are used, the load should not exceed the power strip input rating. Consult an electrician for more information if you have questions about power loads, power requirements, and input ratings.

If a receptacle (power outlet) that you intend to use with your tablet equipment appears to be damaged or corroded, do not use the outlet until it is replaced by a qualified electrician.

Do not bend or modify the plug. If the plug is damaged, contact the manufacturer to obtain a replacement.

Do not share an electrical outlet with other home or commercial appliances that draw large amounts of electricity; otherwise, unstable voltage might damage your tablet, data, or attached devices.

Some products are equipped with a three-pronged plug. This plug fits only into a grounded electrical outlet. This is a safety feature. Do not defeat this safety feature by trying to insert it into a non-grounded outlet. Are you really reading through all of this? If you cannot insert the plug into the outlet, contact an electrician for an approved outlet adapter or to replace the outlet with one that enables this safety feature. Never overload an electrical outlet. The overall system load should not exceed 80 percent of the branch circuit rating. Consult an electrician for more information if you have questions about power loads and branch circuit ratings.

Be sure that the power outlet you are using is properly wired, easily accessible, and located close to the equipment. Do not fully extend power cords in a way that will stress the cords.

Be sure that the power outlet provides the correct voltage and current for the product you are installing.

Battery Warning

WARNING:

Do not attempt to remove or replace the built-in rechargeable battery. Replacement of the battery must be done by a HoverCam-authorized repair technician, or by direction from HoverCam Technical Support.

Only recharge the battery strictly according to instructions included in the product documentation. Batteries supplied by HoverCam for use with your product have been tested for compatibility and should only be replaced with approved parts. A battery other than the one specified by HoverCam, or a disassembled or modified battery is not covered by the warranty.

Battery abuse or mishandling can cause overheating, liquid leakage, or an explosion. To avoid possible injury, do the following:

- Do not open, disassemble, or service any battery.
- Do not crush or puncture the battery.
- Do not short-circuit the battery, or expose it to water or other liquids.
- Keep the battery away from children.
- **Keep the battery away from fire.**
- Stop using the battery if it is damaged, or if you notice any discharge or the buildup of foreign materials on the battery leads.
- Store the rechargeable batteries or products containing the rechargeable batteries at room temperature, charged to approximately 30 to 50% of capacity. We recommend that the batteries be charged about once per week to prevent over-discharge.
- Do not put the battery in trash that is disposed of in landfills. When disposing of the battery, comply with local ordinances or regulations.

Heat and Product Ventilation

WARNING:

Tablets, ac power adapters, and many accessories can generate heat when turned on and when batteries are charging. Tablets can generate a significant amount of heat due to their compact size. Always follow these basic precautions:

- When your tablet is turned on or the battery is charging, some parts may become hot. Avoid keeping your hands, your lap, or any other part of your body in contact with a hot section of the tablet for any extended length of time. When you use the touchscreen, avoid keeping your palms on the device for a prolonged period of time. Your tablet generates some heat during normal operation. The amount of heat depends on the amount of system activity and the battery charge level. Extended contact with your body, even through clothing, could cause discomfort or even a skin burn. Periodically take breaks from using the touchscreen by lifting your hands from the device; and be careful not to use the device for any extended length of time.
- Do not operate your tablet/podium or charge the battery near flammable materials or in explosive environments.
- Ventilation slots, fans and/or heat sinks are provided with the product for safety, comfort, and reliable operation. These features might inadvertently become blocked by placing the product on a bed, sofa, carpet, or other flexible surface. Never block, cover, or disable these features.
- When the ac power adapter is connected to an electrical outlet and your device, it generates heat. Do not place the adapter in contact with any part of your body while using it. Never use the ac power adapter to warm your body. Extended contact with your body, even through clothing, may cause a skin burn.

For your safety, always follow these basic precautions with your tablet:

- Regularly inspect the outside of the tablet for dust accumulation.
- Remove dust from vents and any perforations in the bezel. More frequent cleanings might be required for tablets in dusty or high-traffic areas.
- Do not restrict or block any ventilation openings.
- Do not operate your tablet inside furniture, as this might increase the risk of overheating.
- Airflow temperatures into the tablet should not exceed 35°C (95°F).

Electrical current safety information

WARNING:

Electric current from power, telephone, and communication cables is hazardous.

To avoid a shock hazard:

- Do not use your product during a lightning storm.
- Do not connect or disconnect any cables or perform installation, maintenance, or reconfiguration of this product during an electrical storm.
- Connect all power cords to a properly wired and grounded electrical outlet.
- Connect to properly wired outlets any equipment that will be attached to this product.
- Whenever possible, use one hand only to connect or disconnect signal cables.
- Never turn on any equipment when there is evidence of fire, water, or structural damage.
- Do not use your tablet until all internal parts enclosures are fastened into place. Never use the tablet when internal parts and circuits are exposed.

Liquid Crystal Display (LCD) Notice

CAUTION:

The liquid crystal display (LCD) is made of glass, and rough handling or dropping the tablet can cause the LCD to break. If the LCD breaks and the internal fluid gets into your eyes or on your hands, immediately wash the affected areas with water for at least 15 minutes; if any symptoms are present after washing, get medical care.

Choking Hazard Notice

CHOKING HAZARD – Product contains small parts. Keep away from children under three years.

Plastic Bag Notice

DANGER:

Plastic bags can be dangerous. Keep plastic bags away from babies and children to avoid danger of suffocation.

Glass Parts Notice

CAUTION:

Some parts of your product may be made of glass. This glass could break if the product is dropped on a hard surface or receives a substantial impact. If glass breaks, do not touch or attempt to remove it. Stop using your product until the glass is replaced by trained service personnel.

HoverCam may not offer the products, services, or features discussed in this document in all countries. Consult your local HoverCam representative for information on the products and services currently available in your area. Any reference to a HoverCam product, program, or service is not intended to state or imply that only that HoverCam product, program, or service may be used. Any functionally equivalent product, program, or service that does not infringe any HoverCam intellectual property right may be used instead. However, it is the user's responsibility to evaluate and verify the operation of any other product, program, or service.

HoverCam may have patents or pending patent programs covering subject matter described in this document. The furnishing of this document does not give you any license to these patents. You can send license inquiries, in writing, to: sales@hovercam.com, Attn: HoverCam Legal.

HoverCam PROVIDES THIS PUBLICATION "AS IS" WITHOUT WARRANTY OF ANY KIND, EITHER EXPRESS OR IMPLIED, INCLUDING, BUT NOT LIMITED TO, THE IMPLIED WARRANTIES OF NON-INFRINGEMENT, MERCHANTABILITY OR FITNESS FOR A PARTICULAR PURPOSE. Some jurisdictions do not allow disclaimer of express or implied warranties in certain transactions, therefore, this statement may not apply to you.

This information could include technical inaccuracies or typographical errors. Changes are periodically made to the information herein; these changes will be incorporated in new editions of the publication. HoverCam may make improvements and/or changes in the product(s) and/or the application(s) described in this publication at any time without notice.

The products described in this document are not intended for use in implantation or other life support applications where malfunction may result in injury or death to persons. The information contained in this document does not affect or change HoverCam product specifications or warranties. Nothing in this document shall operate as an express or implied license or indemnity under the intellectual property rights of HoverCam or third parties. All information contained in this document was obtained in specific environments and is presented as an illustration. The result obtained in other operating environments may vary.

HoverCam may use or distribute any of the information you supply in any way it believes appropriate without incurring any obligation to you.

Any references in this publication to non-HoverCam Web sites are provided for convenience only and do not in any manner serve as an endorsement of those Web sites. The materials at those Web sites are not part of the materials for this HoverCam product, and use of those Web sites is at your own risk. Any performance data contained herein was determined in a controlled environment. Therefore, the result obtained in other operating environments may vary significantly. If you've read this far, you're probably a lawyer. Some measurements may have been made on development-level systems and there is no guarantee that these measurements will be the same on generally available systems. Furthermore, some measurements may have been estimated through extrapolation. Actual results may vary. Users of this document should verify the applicable data for their specific environment.

© Copyright HoverCam 2022

This document is copyrighted by HoverCam and HoverCam may update this document at any time without notice. To obtain the most up-to-date documentation for your Podium, go to:

www.hovercam.com/support

Trademarks

HoverCam is a trademark of Pathway Innovations, Inc. in the United States, other countries, or both. Microsoft and Windows are trademarks of the Microsoft group of companies.

The terms HDMI and HDMI High-Definition Multimedia Interface are trademarks or registered trademarks of HDMI Licensing LLC in the United States and other countries.

Wi-Fi and Wi-Fi Alliance are registered trademarks of Wi-Fi Alliance.

USB-C is a trademark of USB Implementers Forum.

Other company, product, and service names may be trademarks or service marks of others.

Patents

The following pending U.S. patents have been filed by Pathway Innovations, Inc. (d.b.a. HoverCam):

15/969,732	62/696,037
15/968,726	62/700,188
14/122,020	62/720,316
14/382,181	62/720,344
16/163,424	15/410,580
62/689,027	15/650,605
62/689,041	15/849,655
62/689,128	

Visit our full list of patents online at: <https://www.hovercam.com/patents>

hovercam®

Pilot X/S

(858) 750-3499
sales@hovercam.com