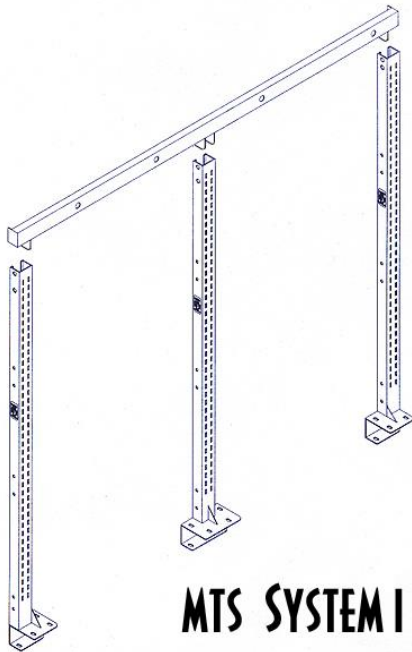
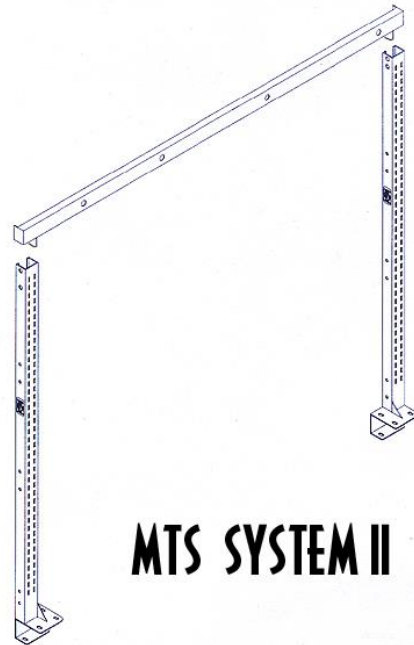


# Quick Ship



**MTS SYSTEM I**



**MTS SYSTEM II**

## **IAC INDUSTRIES**

3831 S BULLARD AVE., GOODYEAR, AZ 85338

Phone (714) 990-8997 Fax (714) 990-0557  
www.iacindustries.com

**QS Multi-Task Systems I & II**

**Assembly Instructions**

REV. (042318P65)

# TABLE OF CONTENTS:

<u>Page</u>	<u>Product</u>
3.	ESD Drilling Instructions
4.	QS MTS WSM 3 Figure 1 Vertical Frame Systems
5.	QS MTS WSM 3 Post on new or existing IAC Bench
6.	QS MTS WSM 2 Figure 2 Vertical Frame Systems
7.	QS MTS WSM 2 Post on new or existing IAC Bench
8.	QS MTS WSM 2 Post on non-IAC Stock Bench
9.	QS MTS STD. & ESD Utility Shelf
10.	QS MTS STD. & ESD Multi Rail Bin Holder
11.	QS MTS CRT Platform 25lb
12.	QS MTS Econo Light Assembly
13.	QS MTS Tool Trolley Assembly LT
14.	QS MTS Tool Trolley Assembly NLT
15.	QS MTS Electrical Outlet Channel
16.	QS MTS Flat Panel Display
17.	QS FPD Keyboard Holder with Mouse Pad Assembly
18.	QS MTS Swing Arm Pegboard Assembly
19-21	QS MTS Drill Templates (Detach FULL SIZE instructions)



## **WARNING:**

**ALL PARTICLE BOARD USED IN IAC INDUSTRIES PRODUCTS ARE SOURCED ONLY FROM VENDORS THAT ARE CARB ATCM PHASE 2 AND TSCA TITLE VI COMPLIANT WITH VALID**

**CERTIFICATES.** Drilling, Sawing, Sanding or Machining Wood products can expose you to wood dust, a substance known to the state of California to cause cancer. Avoid inhaling dust generated from wood products or use a dust mask to other safeguards for personal protection. This product can expose you to chemicals, including formaldehyde, which is known to the state of California to cause cancer, and methanol, which is known to the state of California to cause birth defects or other reproductive harm. For more information please visit, [www.P65WARNINGS.CA.GOV/WOOD](http://www.P65WARNINGS.CA.GOV/WOOD). COPY OF VENDOR CERTIFICATE AVAILABLE UPON REQUEST.

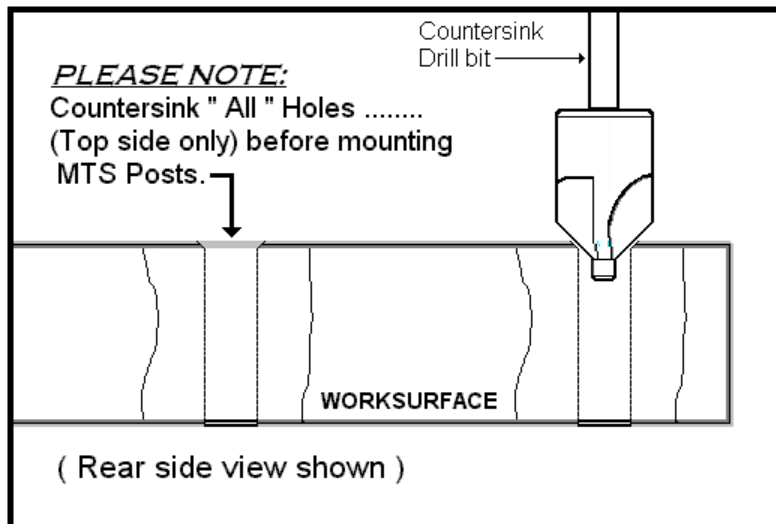
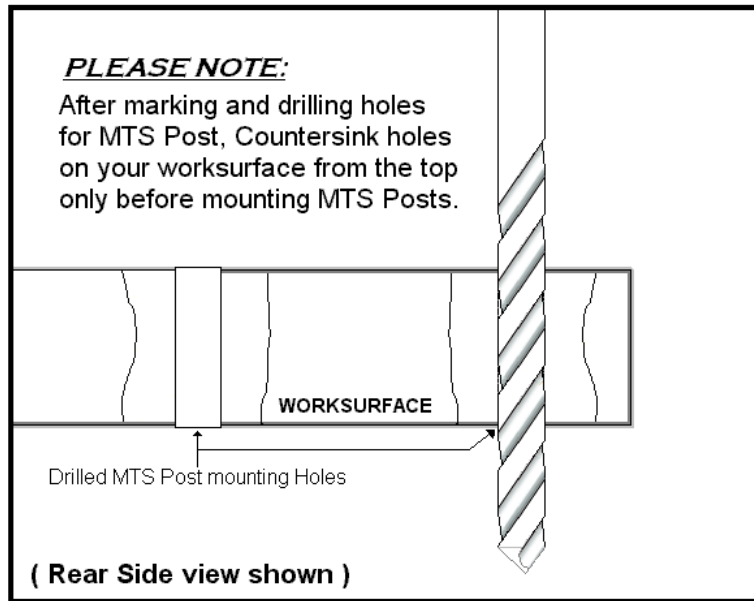
## ADDITIONAL DRILLING INSTRUCTIONS FOR **ESD** WORKSURFACES ONLY:

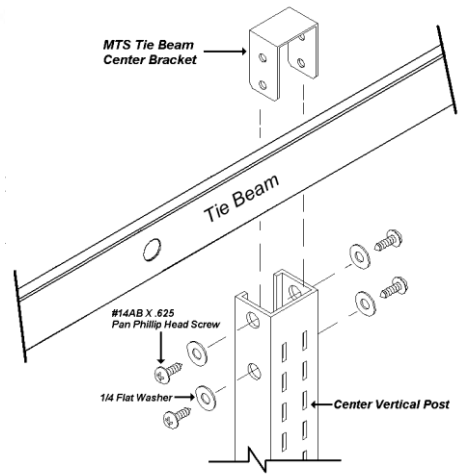
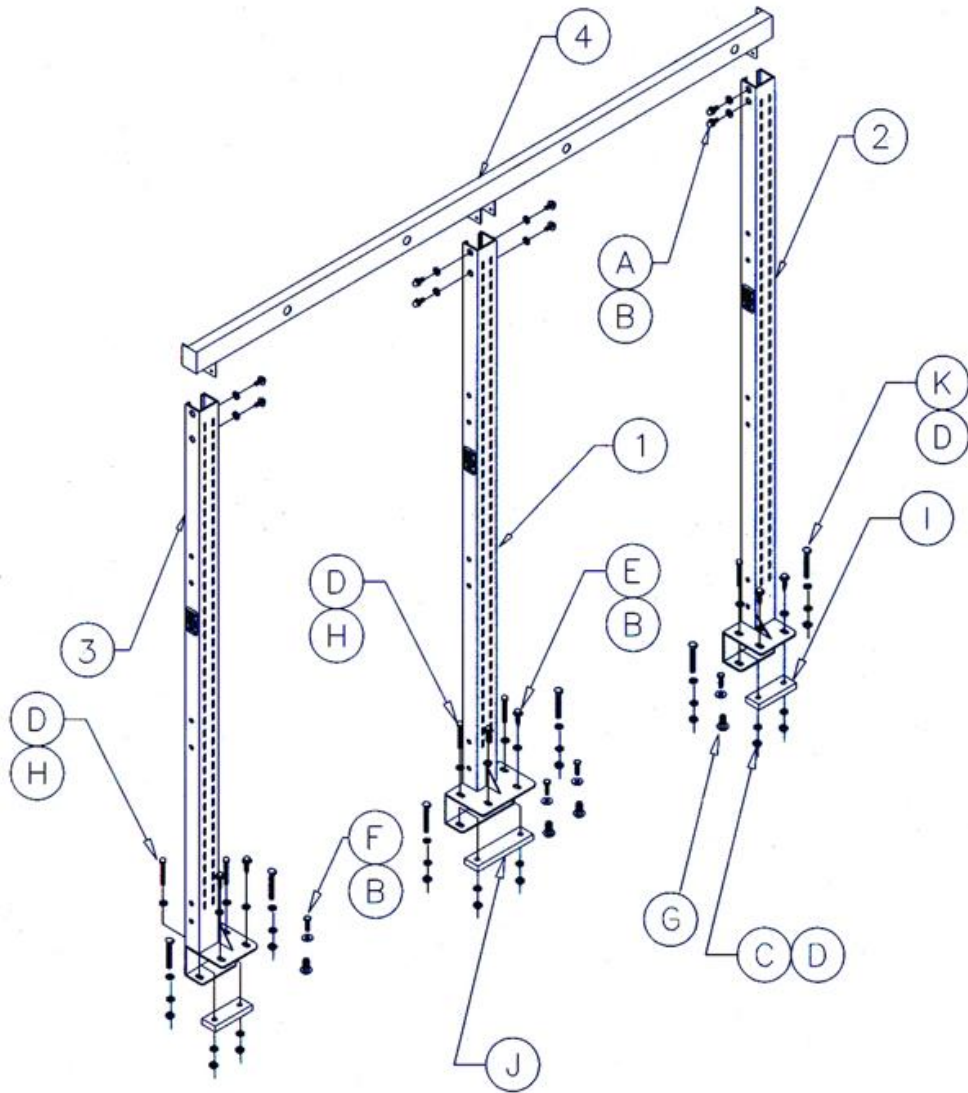
Before mounting your MTS posts to the worksurface, countersink **all** holes for your MTS posts on the top side of the worksurface only.

This will insure that any carbon from the worksurface that may have been lifted by the drill bit when drilling the holes for the posts is removed and doesn't interfere with any part of the MTS post.

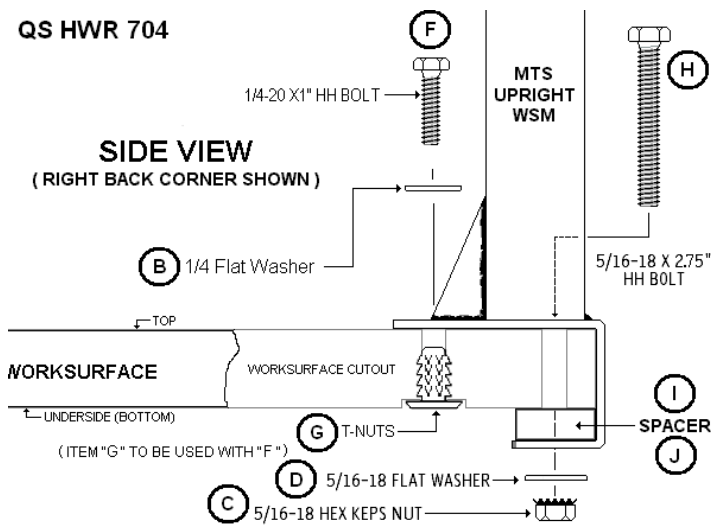
Drilling tip: countersink your holes with little to no pressure at the start of your drilling, this will insure that the countersink bit makes an even countersink.

(Note: do not countersink to deep. You only need to go down approximately 1/16".)

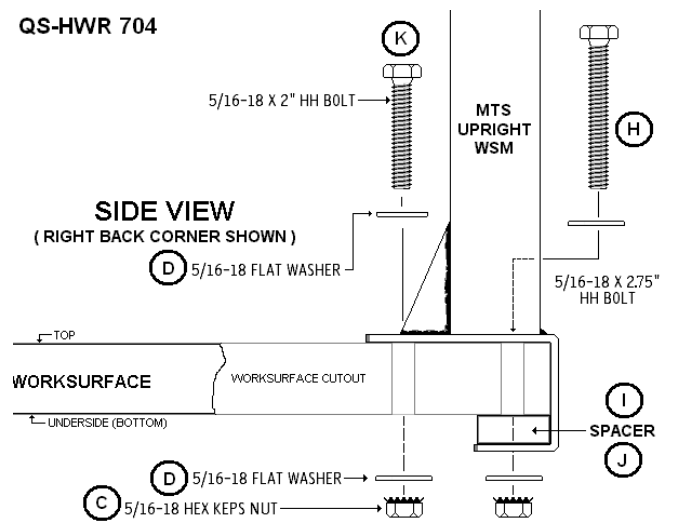




QS HWR 704



QS-HWR 704



**QS MTS I (Multi Task System) Frame, 60", 72" & 96"**  
**WORKSURFACE MOUNT (3 Post)**  
(SEE FIG. 1, PAGE 4)

Tools Required:     Drill Motor  
                              3/8" Diameter Drill Bit  
                              1/2" End Wrench or Socket  
                              1/4" End Wrench or Socket

**CAUTION: Wear eye protection when drilling.**

**CAUTION: Holes must be drilled straight.**

**Parts List**

<b>Item</b>	<b>Description</b>	<b>Qty</b>
1	Middle Vertical Frame	1**
2	Right Vertical Frame	1
3	Left Vertical Frame	1
4	Vert Channel Tie Beam	1
A	SMS PPH Screw, #14AB x .625"L	8*
B	Flat Washer, 1/4	12*
C	Hex KEPS Nut, 5/16-18	12*
D	Flat Washer, 5/16	24*
E	Lag Bolt, 1/4x1"L	6*
F	Hex Head Bolt, 1/4-20x1"L	4*
G	T-Nut, 1/4-20	4*
H	Hex Head Bolt, 5/16-18x2.75"L	6*
I	End Spacer, for 1/2" Gap	2*
J	Middle Spacer, for 1/2" Gap	1*
K	Bolt, 5/16-18x 2.00"L	6*
L	Bracket, MTS Tie Beam Center	1*

\*Contained in Hardware Kit # **QSHWR704**

\*\* Only used on MTS SYSTEM I

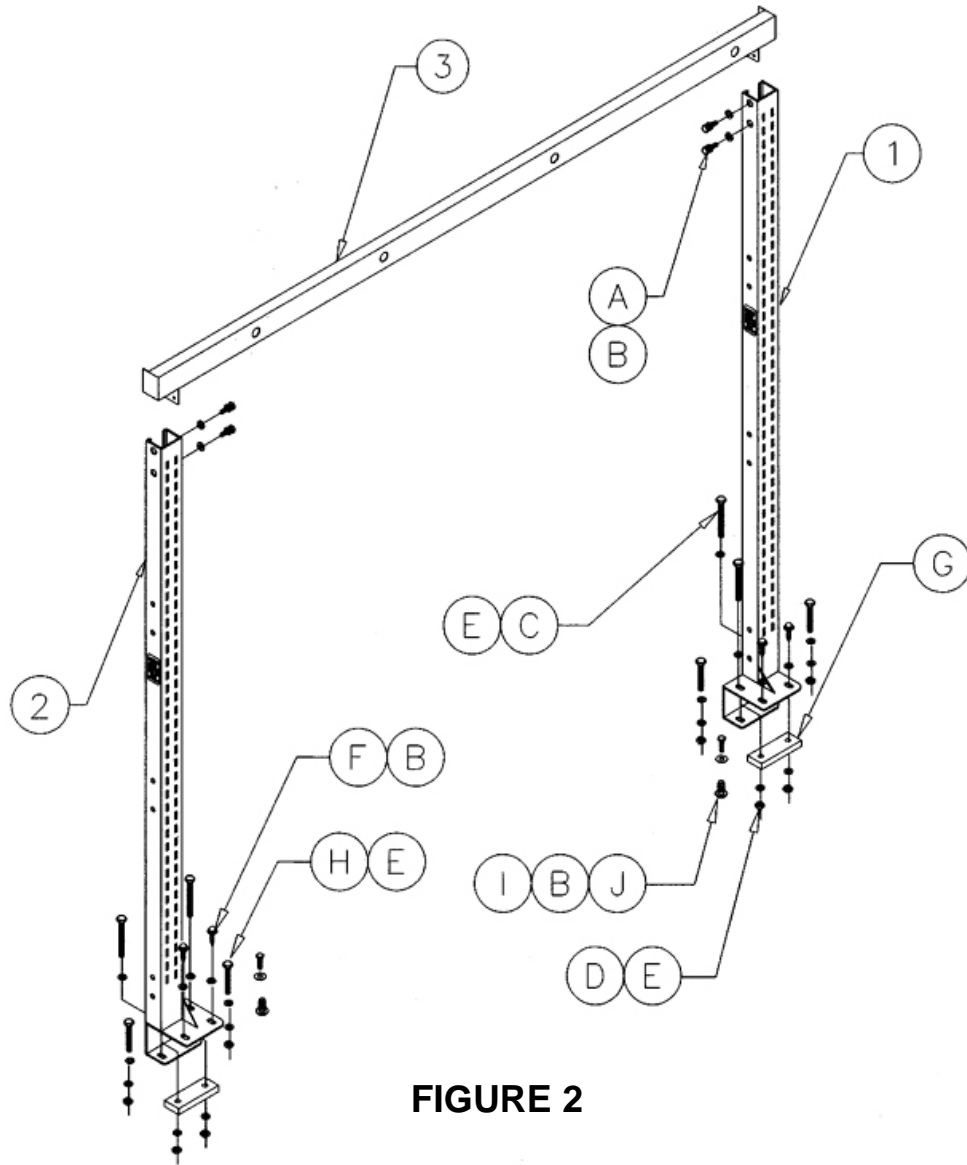
**Instructions:**

Tape drill templates (provided on the back pages) Align the appropriate edge of the template with the rear edge of the worksurface and tape in place.  
**\*Follow instructions on templates.**

**If your Worksurface is 30" deep,** press 1/4-20 T-nuts into the (4) counter-bored holes\*. Position Vertical Frame members in position and use (6) 5/16x2.75" bolts, nuts and washers in rear holes. Use spacers provided to fill the gap underneath the worksurface (if applicable). Use (4) 1/4-20x1" hex head bolts with 1/4 flat washers in holes with T-Nuts.

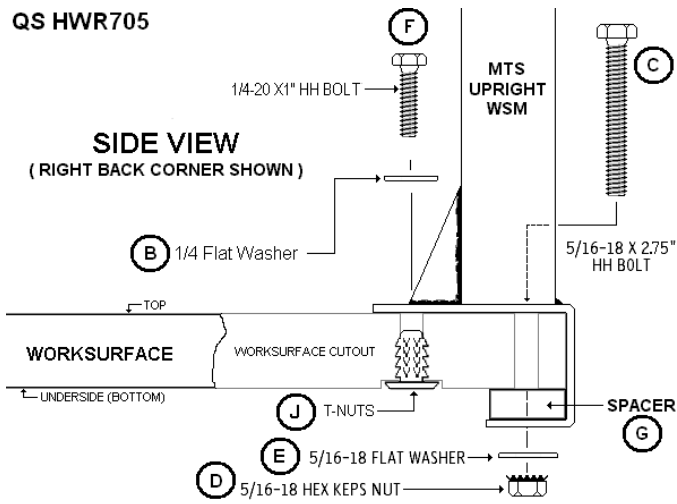
**If you have a 36" deep worksurface, no T-Nuts** will be used. Secure Vertical Frame members using (6) 5/16x2.75" bolts, nuts and washers in the rear and (6) 5/16x 2" bolts, nuts and washers in the front. Use spacers provided to fill the gap underneath the worksurface (if applicable).

Install the MTS Tie Beam item 4 at the top of the verticals by first installing the center tie beam mounting bracket item L through the slots in the inside of the bottom flange of the tie beam and attaching and fitting it and the tabs on each end of the tie beam into the top of the MTS verticals. Attach the tie beam using the #14AB X .625 PPH screws item A and 1/4 flat washers item B. Squaring the two outside MTS verticals so they are perpendicular to the worksurface tighten the hardware holding the verticals to the worksurface. Lastly, square the center MTS vertical and tighten the hardware that attaches the center vertical flange to the worksurface.

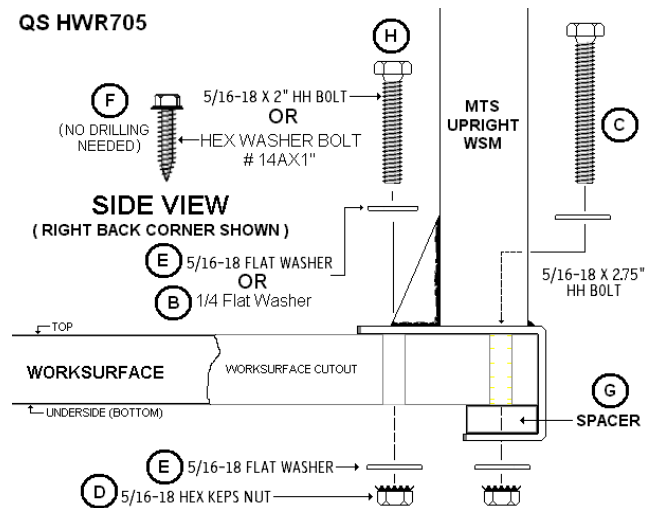


**FIGURE 2**

QS HWR705



QS HWR705



**QS MTS II Frame, WORKSURFACE MOUNT**  
**Installed on a new or existing IAC Bench See FIG. 2, PAGE 6**

Tools Required: Drill Motor  
 3/8" Diameter Drill Bit  
 1/2" End Wrench or Socket  
 1/4" End Wrench or Socket

**CAUTION: Wear eye protection when drilling.**

**CAUTION: Holes must be drilled straight.**

**Parts List**

<b>Item</b>	<b>Description</b>	<b>Qty</b>
1	Right Vertical Frame	1
2	Left Vertical Frame	1
3	Vert. Channel Tie Beam	1
A	SMS PPH Screw, #14AB x .625"L	4*
B	Flat Washer, 1/4	8*
C	Hex Head Bolt, 5/16-18x2.75"L	4*
D	Hex KEPS Nut, 5/16-18	8*
E	Flat Washer, 5/16	16*
F	Lag Bolt, 1/4x1"L	4*
G	End Spacer, for 1/2" Gap	2*
H	Bolt, 5/16-18x 2.00"L	4*
I	Hex Head Bolt, 1/4-20x1"L**	2*
J	T-Nut, 1/4-20**	2*

\*Contained in Hardware Kit # **QS HWR705**

\*\* Used together

**Instructions:**

Tape drill templates (provided on the back pages) Align the appropriate edge of the template with the rear edge of the worksurface and tape in place.  
**\*Follow instructions on templates.**

**If your Worksurface is 30" deep**, press 1/4-20 T-nuts into the (2) counter-bored holes\*. Position Vertical Frame members in position and use (4) 5/16x2.75"bolts, nuts and washers in rear holes. Use (2) 1/4-20x1" hex head bolts and 1/4 flat washers in holes with T-Nuts. and (2) 5/16x 2" bolts, nuts and washers in the other (2) front holes. Use spacers provided to fill the gap underneath the worksurface (if applicable).

**If you have a 36" worksurface, no** T-Nuts will be used. Secure Vertical Frame members with (4) 5/16x2.75" bolts, nuts and washers and (4) 5/16x 2" bolts, nuts and washers in the front. Use spacers provided to fill the gap underneath the worksurface (if applicable).

Install the MTS Tie Beam item 3 by first fitting it and the tabs on each end of the tie beam into the top of the MTS verticals. Attach the tie beam using the #14AB X .625 PPH screws item A and 1/4 flat washers item B. Squaring the two MTS verticals so they are perpendicular to the worksurface tighten the hardware holding the two verticals to the worksurface.

## QS MTS II Frame, WORKSURFACE MOUNT Installed on a non-IAC Bench See FIG. 2, PAGE 6

Tools Required: Drill Motor  
 3/8" Diameter Drill Bit  
 1/2" End Wrench or Socket  
 1/4" End Wrench or Socket

**CAUTION: Wear eye protection when drilling.**

**CAUTION: Holes must be drilled straight.**

### Parts List

Item	Description	Qty
1	Right Vertical Frame	1
2	Left Vertical Frame	1
3	Vert. Channel Tie Beam	1
A	SMS PPH Screw, #14AB x .625"L	4*
B	Flat Washer, 1/4	8*
C	Hex Head Bolt, 5/16-18x2.75"L	4*
D	Hex KEPS Nut, 5/16-18	8*
E	Flat Washer, 5/16	16*
F	Lag Bolt, 1/4x1"L	4*
G	End Spacer, for 1/2" Gap	2*
H	Bolt, 5/16-18x 2.00"L	4*
I	Hex Head Bolt, 1/4-20x1"L**	2*
J	T-Nut, 1/4-20**	2*

\*Contained in Hardware Kit # **QS HWR705**

\*\* Used together

### Instructions:

**The rear of the worksurface must over hang the bench frame by at least 1-9/16".**

Tape drill templates (provided on the back pages) Align the appropriate edge of the template with the rear edge of the worksurface and tape in place. **Follow instructions on templates.**

**If worksurface overhangs bench frame by less than 3.5"**, drill only the rear most (4) holes to 3/8" diameter through the circles on the template and secure with 5/16x2.75" bolts, nuts and washers. Secure the front of the bracket with (4) 1/4x1" Lag bolts and 1/4 flat washers.

**If worksurface overhangs bench frame by more than 3.5"**, drill all (8) 3/8" diameter holes through the circles on the template. Position Vertical Frame members in position and secure using (4) 5/16"x2.75"L bolts, nuts and washers in the rear and (4) 5/16x 2" bolts, nuts and washers in the front. Use spacers provided to fill the gap underneath the worksurface (if applicable).

Install the MTS Tie Beam item 3 by first fitting it and the tabs on each end of the tie beam into the top of the MTS verticals. Attach the tie beam using the #14AB X .625 PPH screws item A and 1/4 flat washers item B. Squaring the two MTS verticals so they are perpendicular to the worksurface tighten the hardware holding the two verticals to the worksurface.

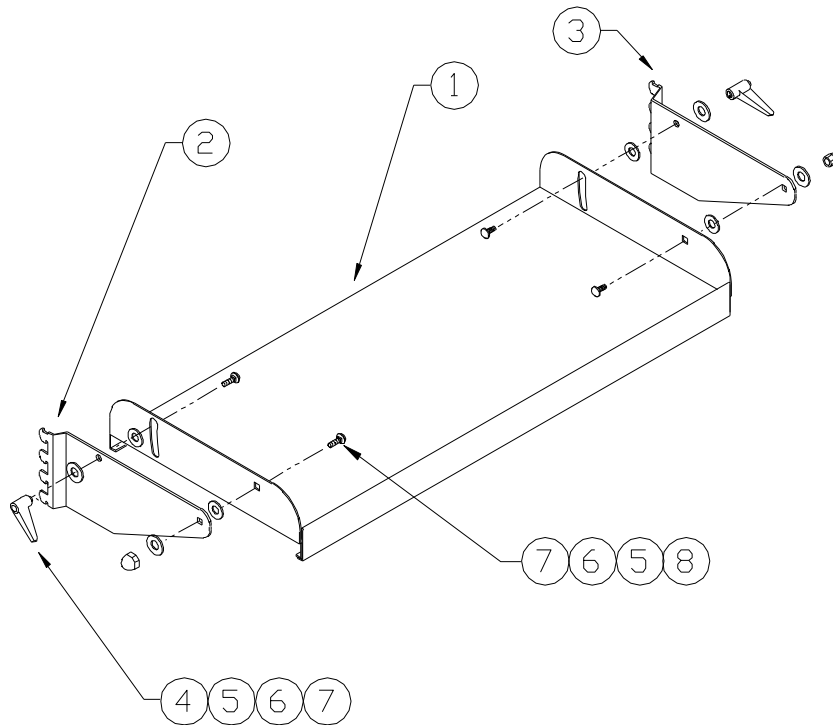


# QS MTS, STD / ESD UTILITY SHELF

Item	Description	Qty
1	STD Shelf / ESD Shelf **	1
2	Clip System Bracket-Left	1
3	Clip System Bracket-Right	1
4	Ratchet Handle 1/4-20	2*
5	Flat Washer 1/4	4*
6	Plastic Washer	4*
7	Carriage Bolt 1/4-20x1/2	4*
8	Acorn Nut 1/4-20	2*

\*Hardware Kit # QS-HWR708

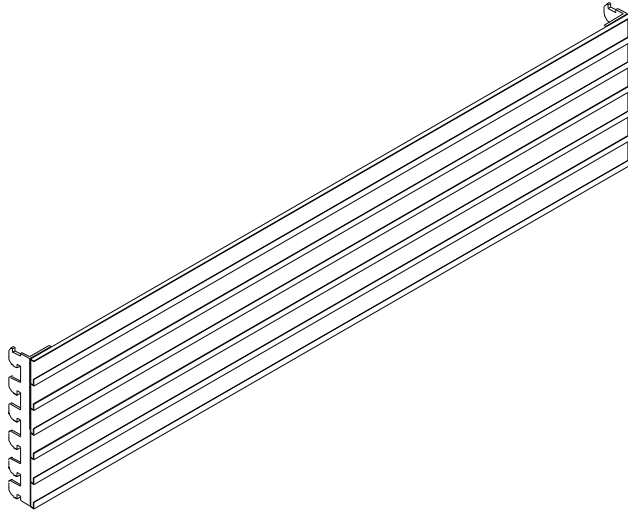
ESD Laminate with Snaps & ESD KIT # HWR115



**Note: Item #6 plastic washer goes between shelf body and shelf bracket.**

## QS MTS MULTI-RAIL BIN HOLDER

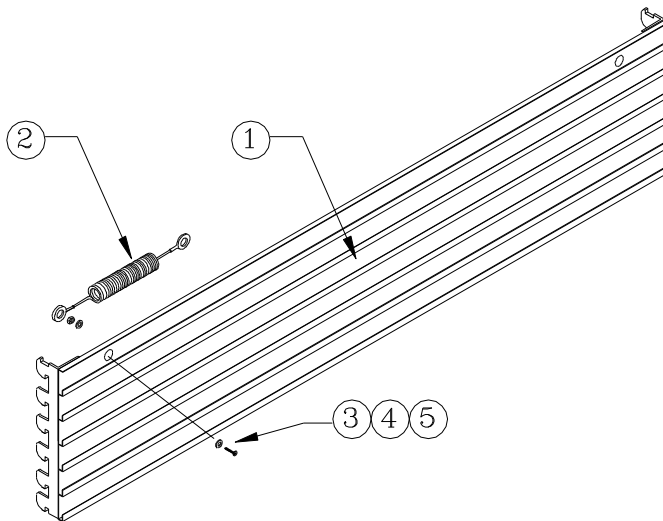
Item	Description	Qty
1	Bin Holder Panel	1



## QS MTS MULTI RAIL BIN HOLDER ESD

Item	Description	Qty
1	ESD Bin Holder	1
2	Cord, Coiled Ground Lug-Lug	1*
3	Nut 8-32 Hex	1*
4	Screw 8-32x1/2 PHP	1*
5	Washer Flat #10	2*

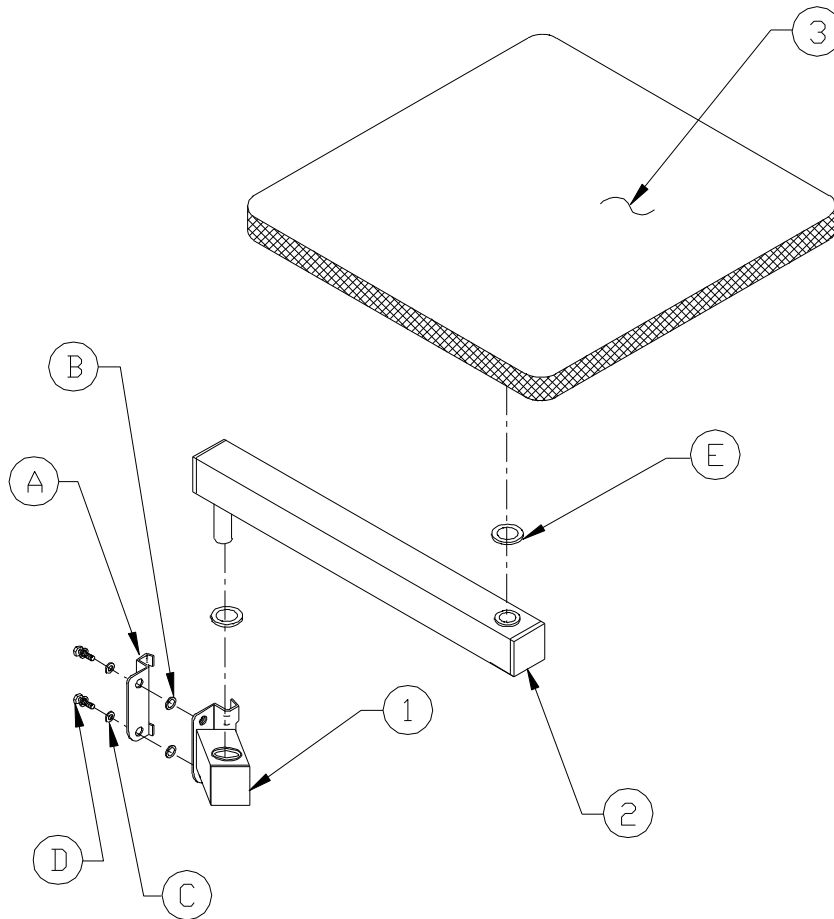
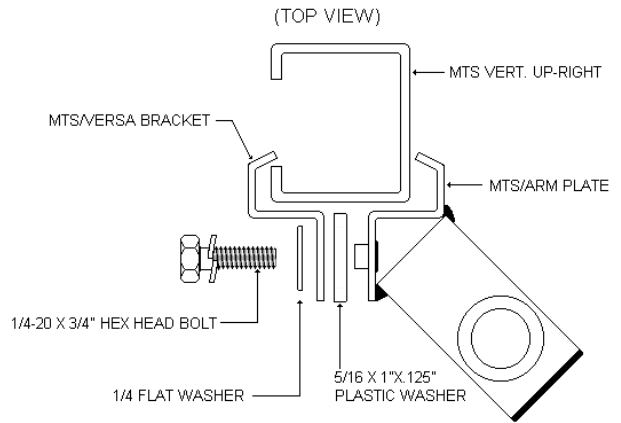
\*Hardware Kit # QS-HWR724



# QS MTS CRT PLATFORM 25LB

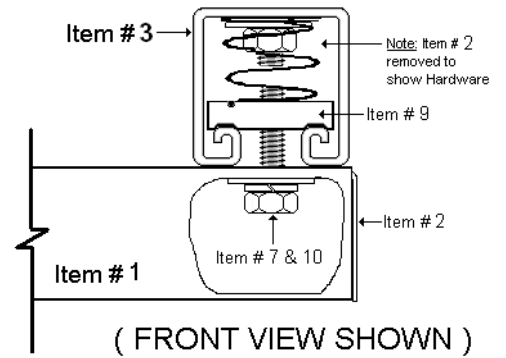
Item	Description	Qty
1	MTS Mounting Plate Sub-Assy	1
A	Versa Bracket	1
D	Bolt, 1/4-20X3/4 HH	2*
C	Washer Flat 1/4"	2*
2	Arm Assembly 15.75"	1
3	Monitor Platform 25lb	1
E	Plastic Washer 3/4x1.25"	2*
B	Washer 5/16x1x1.25	2*

**\*Hardware Kit QS-HWR713**

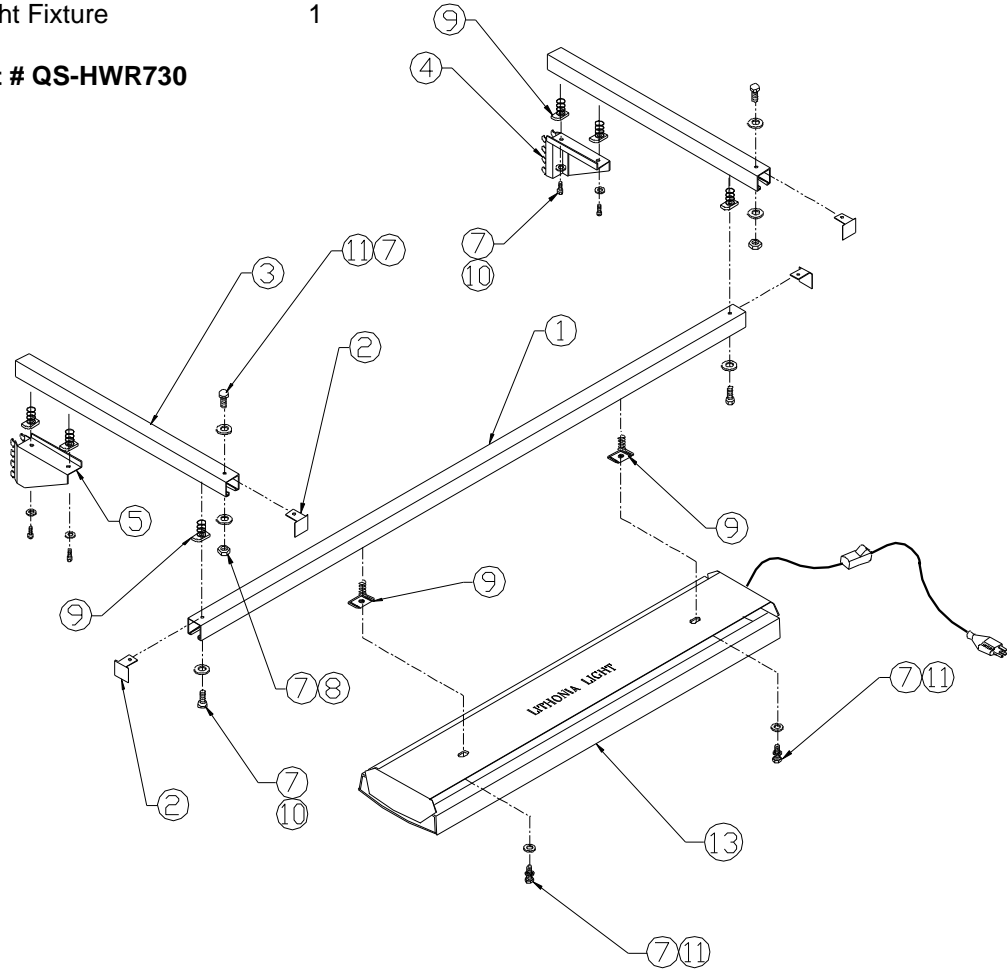


# QS MTS ECONO LIGHT ASSEMBLY

Item	Description	Qty
1	Econo Light Channel	1
2	End Stop, Tool Rail	4*
3	Support Channel	2
4	Clip System Bracket-Right	1*
5	Clip System Bracket-Left	1*
7	Washer Flat 1/4"	12*
8	Nut 1/4-20 Hex	2*
9	Unistrut Nut 1/4-20	8*
10	Bolt 1/4-20x1" HH	6*
11	Bolt 1/4-20x3/4 HH	4*
13	LT Light Fixture	1



\*Hardware Kit # QS-HWR730



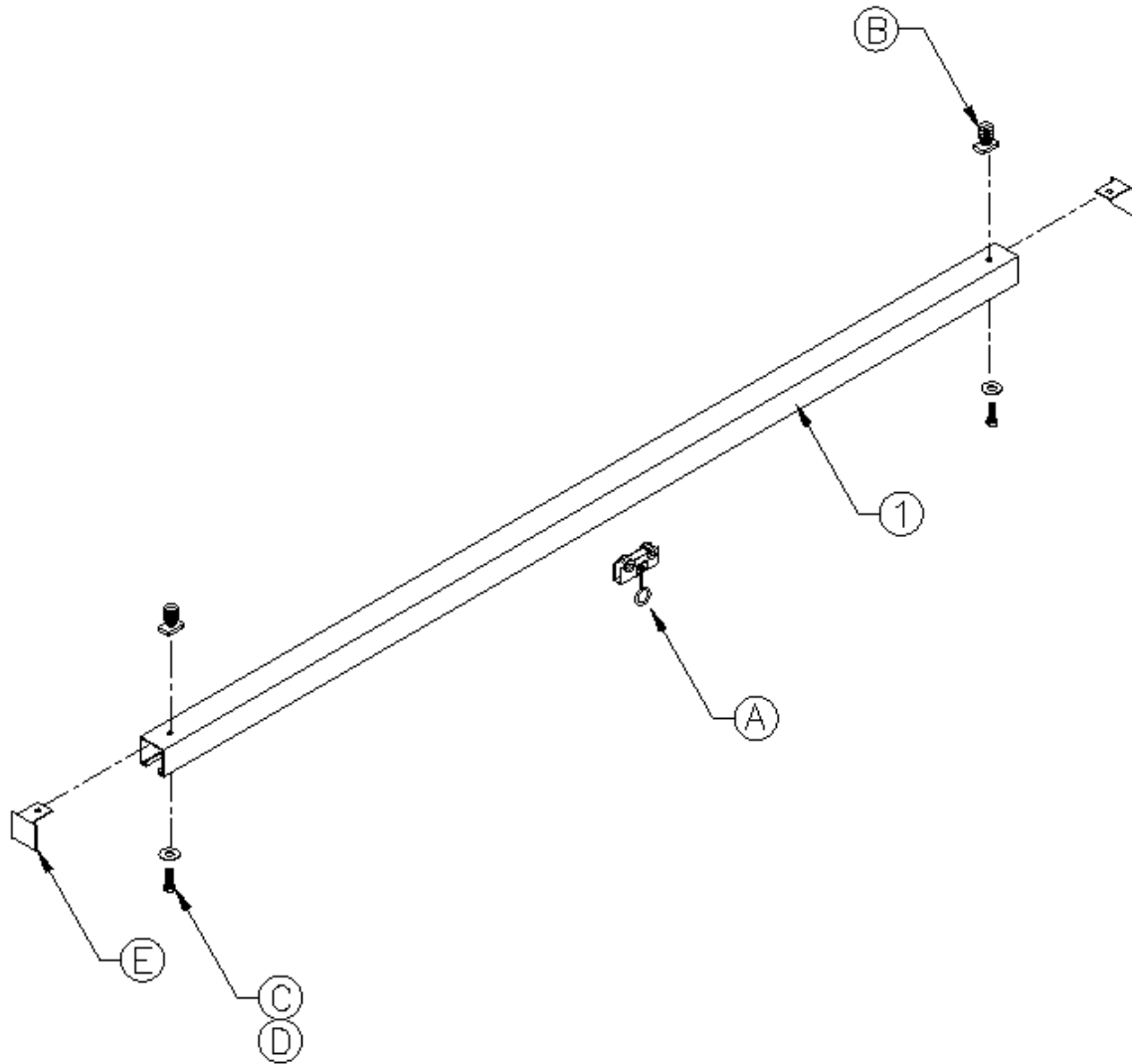
**Note:** The light fixture diffuser and ballast cover must be removed to expose the mounting slots in the light fixture housing. This must be done with extreme caution so that neither part is broken nor that wires are not exposed when the ballast cover is reinstalled.

T8 light tubes are recommended like the F32 T8 light tubes. Install the light tube into the light tube holders located at each end of the light fixture by inserting one of the two pins on each end of the light tube into the channel of light tube holders. Insert the second pin of the light tube in the channel of the light tube holders and slowly turn the light tube into the channels. Rotate the light tube into the light tube holders, being sure both pins of the light tube are in the light tube holder channels, until the light tube locks into place. Before plugging in and turning the light fixture on double check that all four pins of each light tube is in the light tube holders correctly.

## QS MTS TOOL TROLLEY ASSEMBLY LT

Item	Description	Qty
A	Tool Trolley Car	1*
B	Nut, 1/4-20 Unistrut	2*
C	Washer, 1/4 Flat Black	2*
D	Bolt, 1/4-20 x 1.00 HH Black	2*
E	Bracket, MTS Tool Trolley End Stop	1*

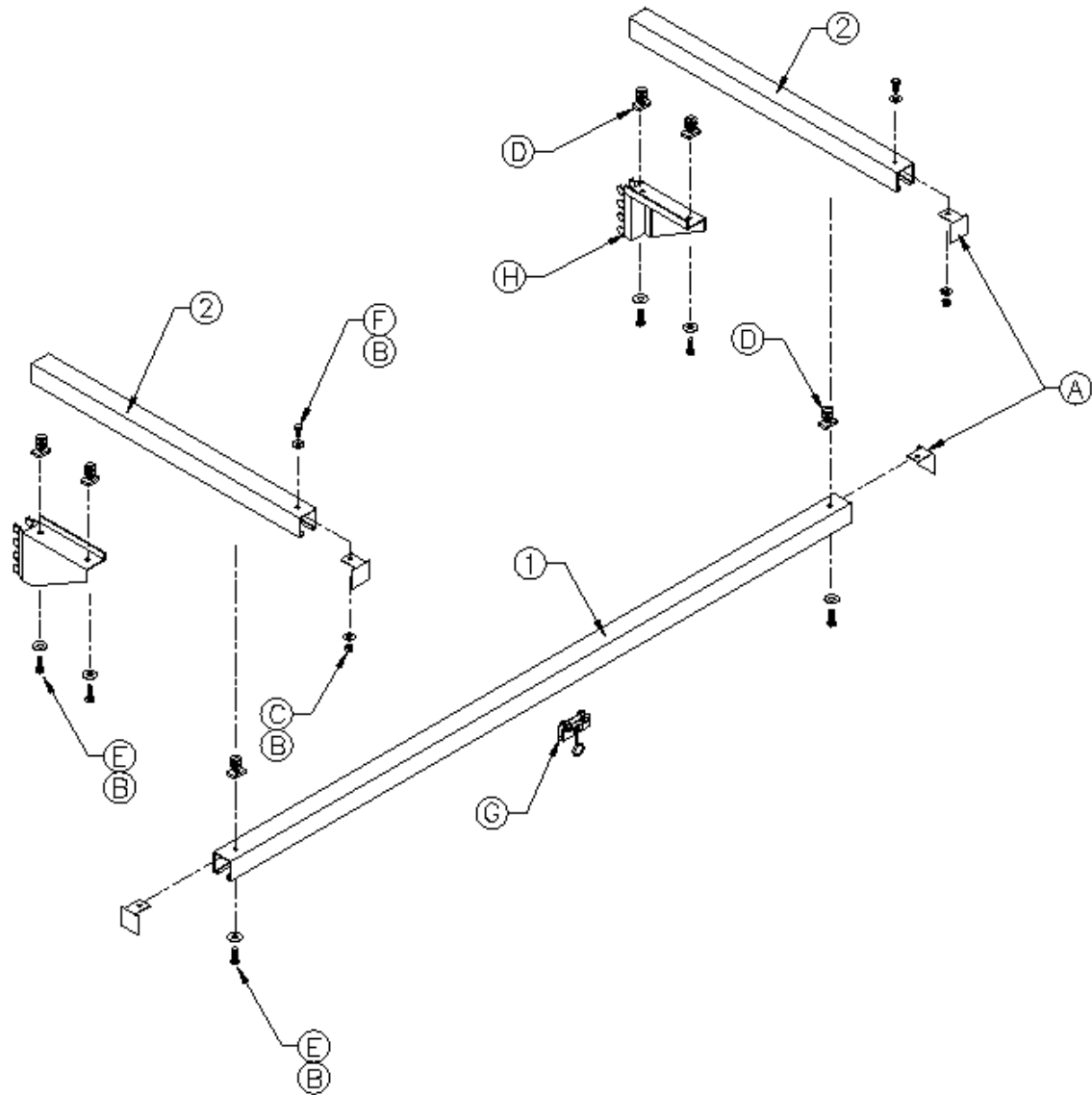
\*Hardware Kit # QS-HWR714



# QS MTS TOOL TROLLEY ASSEMBLY NLT

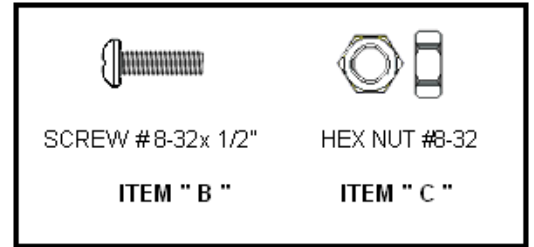
Item	Description	Qty
A	End Stop, Tool Rail	4*
B	Washer Flat 1/4"	10*
C	Nut 1/4-20 Hex	2*
D	Unistrut Nut 1/4-20	6*
E	Bolt 1/4-20x1" HH	6*
F	Bolt 1/4-20x3/4 HH	6*
G	Tool Trolley Car Wheel Type	1*
H	Clip System Bracket-Right	1*
J	Clip System Bracket-Left	1*

\*Hardware Kit # QS-HWR729

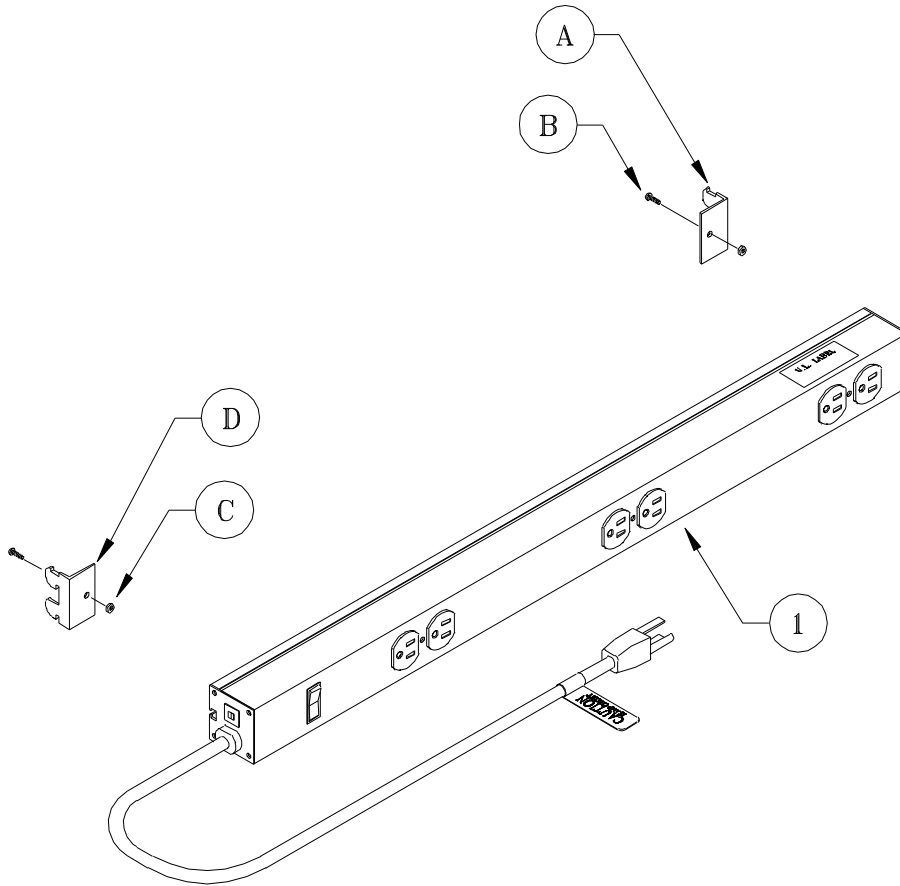


# QS MTS Electrical Outlet Channel

Item	Description	Qty.
1	Electrical Channel Sub-Assy	1
A	Mounting Bracket- Right	1
D	Mounting Bracket- Left	1
B	Screw #8-32x1/2"	2*
C	Hex Nut #8-32	2*



\*Hardware Kit # QS-HWR709

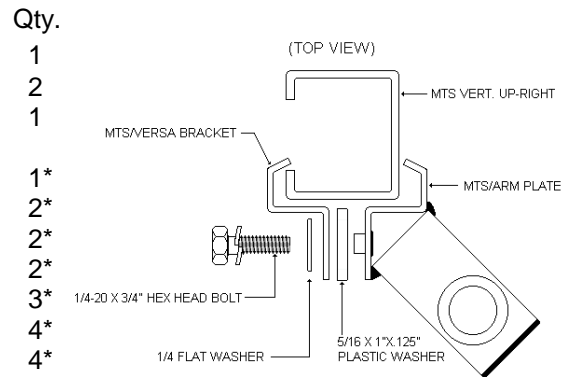


**Note:** Electrical Channel shown is for assembly reference only. Size and outlets may vary.

**Note:** CAUTION: Risk of Electric Shock. Do NOT plug into another Relocatable power tap.

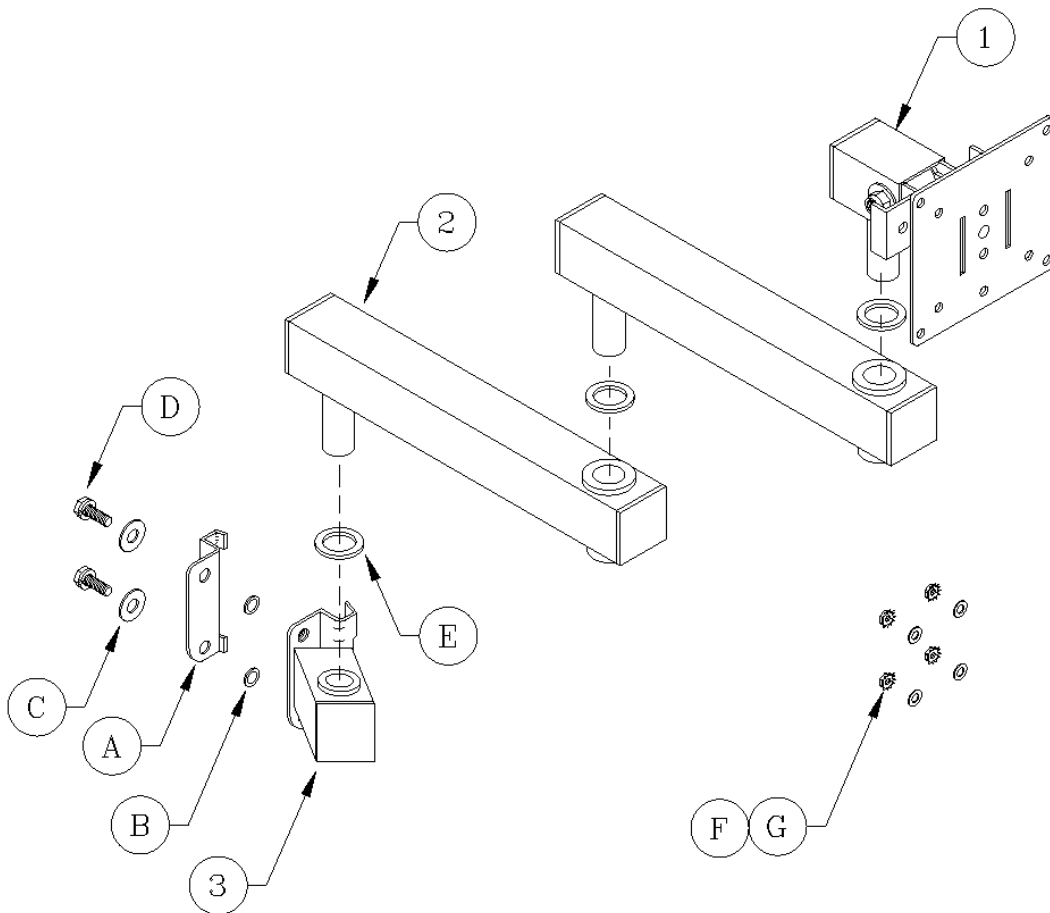
# QS MTS Flat Panel Display

Item	Description
1	D4 FPD Pivot Swivel Sub-Assy
2	Swing Arm Sub-Assy
3	MTS MTG Plate Ext. Arm Sub-Assy
A	MTS Versa Bracket
B	5/16x 1"x .125" Nylon Washer
C	1/4 Flat Washer
D	Bolt 1/4-20x.750 H.H.B
E	.750 ID 1.125 OD x .093 Plastic Washer
F	#10-32 Hex Head KEPS Nut
G	#10 Flat Washer



\*Hardware Kit # QS-HWR036

**PLEASE NOTE:** Hardware items "F" and "G" are not used or needed for this installation.





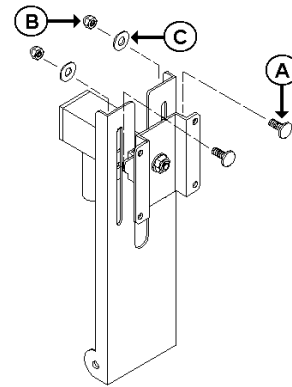
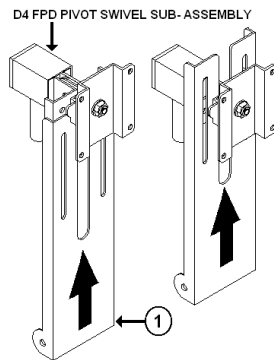
# QS FPD Keyboard Holder with Mouse Pad Assembly

(Please Note: Monitor Front Plate removed from below pictures to shown mounting of Hardware only)

ITEM	DESCRIPTION	QTY
1	FPD Keyboard Holder Vertical Support	1
2	FPD Keyboard Holder Horizontal Support	1
3	Keyboard Shelf with Mouse Tray	1

ITEM	DESCRIPTION	QTY
A	Bolt 1/4-20 x .500 Carriage Zinc	4*
B	Nut 1/4-20 Acorn Zinc	4*
C	Washer 1/4 Flat Black	4*

\*Hardware Kit # QS-HWR044

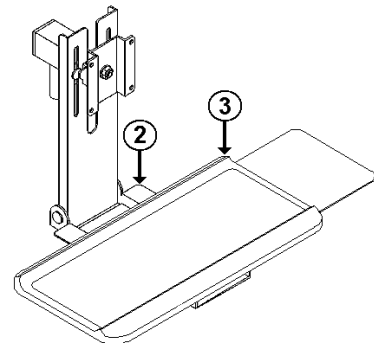
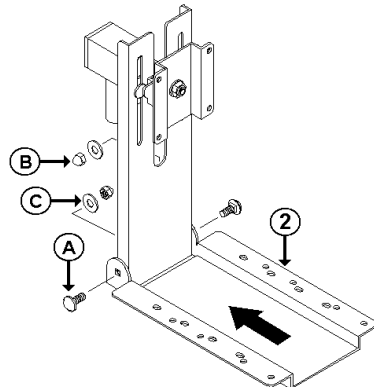


## Step 1:

Slide item 1 FPD Keyboard Holder Vertical Support between the FPD Pivot Swivel Sub-Assembly as shown above.

## Step 2:

Install item 1 FPD Keyboard Holder Vertical Support to the FPD Pivot Swivel Sub-Assembly using two set of 1/4-20 x .500 Carriage bolts item A, 1/4 flat washers item C and 1/4-20 Acorn nuts item B as shown above. Do not tighten hardware yet.



Note: This Hardware is included with the buyout keyboard tray

## Step 3:

Install item 2 to item 1 using I two sets of 1/4-20 x .500 Carriage bolts item A, 1/4 flat washers item C, and 1/4-20 Acorn nuts item B as shown above.

## Step 4:

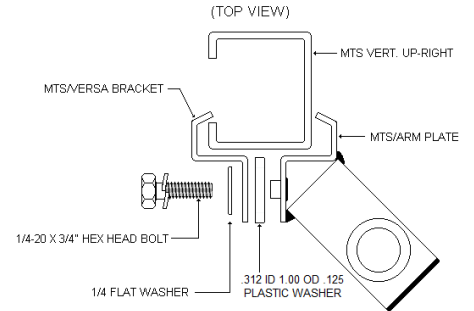
Install Keyboard Shelf with Mouse Tray item 3 to item 2 by placing keyboard tray on top of item 2 and install it using hardware that comes with the buyout tray.

## Step 5:

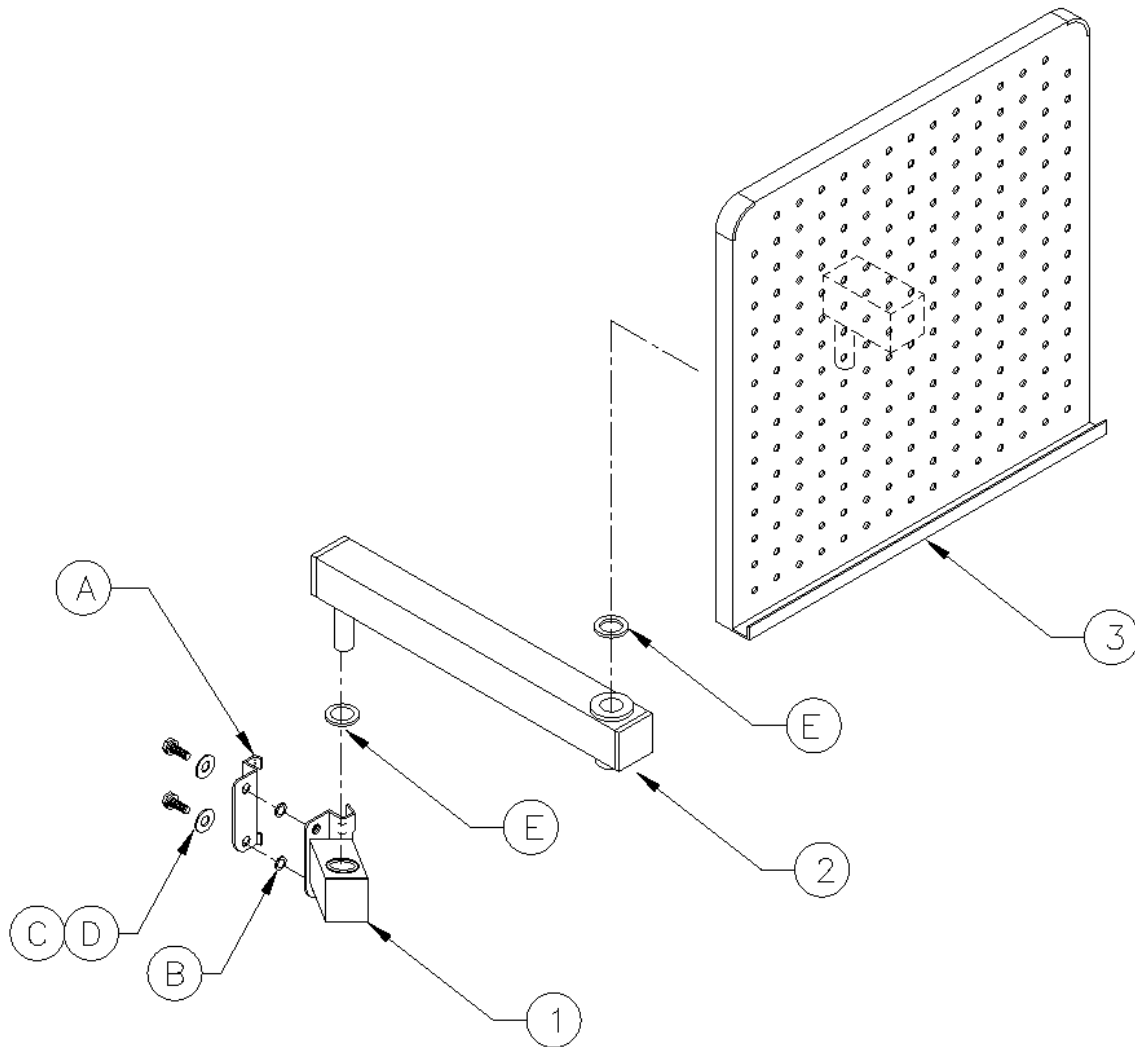
Adjust keyboard tray to height needed and tighten hardware.

# QS MTS Swing Arm Pegboard Assembly

Item	Description	Qty.
1	MTS MTG Plate Ext Arm	1
2	Swing Arm Sub-Assy	1
3	SA Pegboard	1
A	MTS Versa Bracket	1*
B	.312 ID 1"x .125" Nylon Washer	2*
C	1/4 Flat Washer	2*
D	Bolt 1/4-20x.750 H.H.B	2*
E	.750 ID 1.125 OD x .093 Plastic Washer	2*



\*Hardware Kit # QS-HWR 713



## **Tape drill templates: (3) Required Single sided reprints only!**

- Drill template right
- Drill template center
- Drill template left

**(Attach to the end of assembly instructions)**

### **PLEASE NOTE:**

These pages need to be made single sided and “FULL” size to work correctly.

Only copy from Masters!

Only have Engineer Personnel made copies from CAD drawings so to make correct size sheets.