

# Triple Output Programmable DC Power Supply Series IT6300A/B User's Manual



---

Model: IT6322A/IT6332A/IT6333A  
IT6322B/IT6332B/IT6333B  
Version: V2.1

## Notices

© Itech Electronics, Co., Ltd. 2017  
No part of this manual may be reproduced in any form or by any means (including electronic storage and retrieval or translation into a foreign language) without prior permission and written consent from Itech Electronics, Co., Ltd. as governed by international copyright laws.

### Manual Part Number

IT6300A/B-402204

### Revision

Second Edition: February  
28, 2017

Itech Electronics, Co., Ltd.

### Trademarks

Pentium is U.S. registered trademarks of Intel Corporation.

Microsoft, Visual Studio, Windows and MS Windows are registered trademarks of Microsoft Corporation in the United States and/or other countries and regions.

## Warranty

The materials contained in this document are provided "as is", and is subject to change, without prior notice, in future editions. Further, to the maximum extent permitted by applicable laws, ITECH disclaims all warranties, either express or implied, with regard to this manual and any information contained herein, including but not limited to the implied warranties of merchantability and fitness for a particular purpose. ITECH shall not be held liable for errors or for incidental or indirect damages in connection with the furnishing, use or application of this document or of any information contained herein. Should ITECH and the user enter into a separate written agreement with warranty terms covering the materials in this document that conflict with these terms, the warranty terms in the separate agreement shall prevail.

### Technology Licenses

The hardware and/or software described herein are furnished under a license and may be used or copied only in accordance with the terms of such license.

### Restricted Rights Legend

Restricted permissions of the U.S. government. Permissions for software and technical data which are authorized to the U.S. Government only include those for custom provision to end users. ITECH follows FAR 12.211 (technical data), 12.212 (computer software), DFARS 252.227-7015 (technical data--commercial products) for national defense and DFARS 227.7202-3 (permissions for commercial computer software or computer software documents) while providing the customized business licenses of software and technical data.

## Safety Notices

### CAUTION

A CAUTION sign denotes a hazard. It calls attention to an operating procedure or practice that, if not correctly performed or adhered to, could result in damage to the product or loss of important data. Do not proceed beyond a CAUTION sign until the indicated conditions are fully understood and met.

### WARNING

A WARNING sign denotes a hazard. It calls attention to an operating procedure or practice that, if not correctly performed or adhered to, could result in personal injury or death. Do not proceed beyond a WARNING sign until the indicated conditions are fully understood and met.



### NOTE

A NOTE sign denotes important hint. It calls attention to tips or supplementary information that is essential for users to refer to.

## Quality Certification and Assurance

We certify that IT6300A/B series power supply meets all the published specifications at time of shipment from the factory.

## Warranty

ITECH warrants that the product will be free from defects in material and workmanship under normal use for a period of one (1) year from the date of delivery (except those described in the Limitation of Warranty below).

For warranty service or repair, the product must be returned to a service center designated by ITECH.











- The product returned to ITECH for warranty service must be shipped PREPAID. And ITECH will pay for return of the product to customer.
- If the product is returned to ITECH for warranty service from overseas, all the freights, duties and other taxes shall be on the account of customer.



## Limitation of Warranty

This Warranty will be rendered invalid if the product is:

- Damaged resulting from customer-wired circuits or customer-supplied parts or accessories;
- Modified or repaired by customer without authorization;
- Damaged resulting from customer-wired circuits or use in an environment not designated by us;
- The product model or serial number is altered, deleted, removed or made illegible by customer;
- Damaged as a result of accidents, including but not limited to lightning, moisture, fire, improper use or negligence.

## Safety Symbols

	Direct current		ON (power)
	Alternating current		OFF (power)
	Both direct and alternating current		Power-on state
	Chassis (earth ground) symbol.		Power-off state
	Earth (ground) terminal		Reference terminal

	Caution	+	Positive terminal
	Warning (refer to this manual for specific Warning or Caution information)	-	Negative terminal
	A chassis terminal	-	-

## Safety Precautions

The following safety precautions must be observed during all phases of operation of this instrument. Failure to comply with these precautions or specific warnings elsewhere in this manual will constitute a default under safety standards of design, manufacture and intended use of the instrument. ITECH assumes no liability for the customer's failure to comply with these precautions.

### WARNING

- Do not use the instrument if it is damaged. Before operation, check the casing to see whether it cracks. Do not operate the instrument in the presence of inflammable gasses, vapors or dusts.
- The power supply is provided with a three-core power line during delivery and should be connected to a three-core junction box. Before operation, be sure that the power supply is well grounded. Make sure to use the power cord supplied by ITECH.
- Check all marks on the instrument before connecting the instrument to power supply.
- Use electric wires of appropriate load. All loading wires should be capable of bearing maximum short-circuit of electronic load without overheating. If there are multiple loads, each pair of the load power cord must be carry out the full rated short-circuit output current of the power securely.
- Ensure the voltage fluctuation of mains supply is less than 10% of the working voltage range in order to reduce risks of fire and electric shock.
- Do not install alternative parts on the instrument or perform any unauthorized modification.
- Do not use the instrument if the detachable cover is removed or loosen.
- To prevent the possibility of accidental injuries, be sure to use the power adapter supplied by the manufacturer only.
- Never use the instrument with a life-support system or any other equipment subject to safety requirements.

### CAUTION

- Failure to use the instrument as directed by the manufacturer may render its protective features void.
- Always clean the casing with a dry cloth. Do not clean the internals.
- Make sure the vent hole is always unblocked.

## Environmental Conditions



The instrument is designed for indoor use and an area with low condensation. The table below shows the general environmental requirements for the instrument.

Environmental Conditions	Requirements
Operating temperature	0°C to 40°C
Operating humidity	20%-80% (non-condensation)
Storage temperature	-20°C to 70 °C
Altitude	Operating up to 2,000 meters
Installation category	II
Pollution degree	Pollution degree 2



To make accurate measurements, allow the instrument to warm up for 30 min.

## Regulatory Markings

	<p>The CE mark indicates that the product complies with all the relevant European legal directives. The specific year (if any) affixed refers to the year when the design was approved.</p>
	<p>The instrument complies with the WEEE Directive (2002/96/EC) marking requirement. This affix product label indicates that you must not discard the electrical/electronic product in domestic household waste.</p>
	<p>This symbol indicates the time period during which no hazardous or toxic substances are expected to leak or deteriorate during normal use. The expected useful life of the product is 10 years. The product can be used safely during the 10-year Environment Friendly Use Period (EFUP). Upon expiration of the EFUP, the product must be immediately recycled.</p>

## Waste Electrical and Electronic Equipment (WEEE)

### Directive



2002/96/EC Waste Electrical and Electronic Equipment (WEEE) Directive

This product complies with the WEEE Directive (2002/96/EC) marking requirement. This affix product label indicates that you must not discard the electrical/electronic product in domestic household waste.

#### Product Category

With reference to the equipment classifications described in the Annex 1 of the WEEE Directive, this instrument is classified as a "Monitoring and Control Instrument".

To return this unwanted instrument, contact your nearest ITECH office.

## Compliance Information

Complies with the essential requirements of the following applicable European Directives, and carries the CE marking accordingly:

- Electromagnetic Compatibility (EMC) Directive 2014/30/EU
- Low-Voltage Directive (Safety) 2014/35/EU

Conforms with the following product standards:

### EMC Standard

IEC 61326-1:2012/ EN 61326-1:2013 <sup>123</sup>

Reference Standards

CISPR 11:2009+A1:2010/ EN 55011:2009+A1:2010 (Group 1, Class A)

IEC 61000-4-2:2008/ EN 61000-4-2:2009

IEC 61000-4-3:2006+A1:2007+A2:2010/ EN 61000-4-3:2006+A1:2008+A2:2010

IEC 61000-4-4:2004+A1:2010/ EN 61000-4-4:2004+A1:2010

IEC 61000-4-5:2005/ EN 61000-4-5:2006

IEC 61000-4-6:2008/ EN 61000-4-6:2009

IEC 61000-4-11:2004/ EN 61000-4-11:2004

1. The product is intended for use in non-residential/non-domestic environments. Use of the product in residential/domestic environments may cause electromagnetic interference.
2. Connection of the instrument to a test object may produce radiations beyond the specified limit.
3. Use high-performance shielded interface cable to ensure conformity with the EMC standards listed above.

### Safety Standard

IEC 61010-1:2010/ EN 61010-1:2010

## Contents

Quality Certification and Assurance .....	iii
Warranty.....	iii
Limitation of Warranty .....	iii
Safety Symbols.....	iii
Safety Precautions .....	iv
Environmental Conditions .....	v
Regulatory Markings .....	v
Waste Electrical and Electronic Equipment (WEEE) Directive.....	vi
Compliance Information .....	vii
<b>Chapter1      Acceptance and Installation .....</b>	<b>1</b>
1.1 Confirm package contents.....	1
1.2 Installation Position.....	1
1.3 Adjustment of power handle.....	4
1.4 Connecting the Power Cord.....	5
<b>Chapter2      Quick Start .....</b>	<b>6</b>
2.1 Brief Introduction.....	6
2.2 Introduction to the front panel.....	7
2.3 Introduction of the keypad.....	7
2.4 Introduction of indicators on the screen .....	9
2.5 Introduction to the rear panel .....	9
2.6 Power-on selftest .....	10
2.7 Output verification .....	12
<b>Chapter3      Function and Features.....</b>	<b>13</b>
3.1 Front-panel Operation Overview .....	13
3.2 Menu Description.....	14
3.3 Channel Operation .....	20
3.4 OUT ON/OFF .....	20
3.5 Timer operation .....	21
3.6 Set Voltage .....	21
3.7 Current Operation .....	21
3.8 Save and Recall Operation .....	22
3.9 Key Lock Set .....	22
3.10 Protections.....	22
3.11 Remote sense function.....	23
<b>Chapter4      Technical Specifications .....</b>	<b>24</b>
4.1 Major technical parameters .....	24
<b>Chapter5      Communication with PC.....</b>	<b>28</b>
5.1 RS232 interface .....	28
5.2 USB interface .....	29
5.3 GPIB interface .....	30
<b>Appendix .....</b>	<b>31</b>



Specifications of Red and Black Test Lines ..... 31

# Chapter1 Acceptance and Installation

Power supply is a high level safety equipment, there is a protected ground terminal. Before Installation or operation, please read the safety signs and instructions in this manual.

## 1.1 Confirm package contents

Open the package and check the articles within package box before operation. In case of any non-conformity, missing or appearance wearing, please contact ITECH immediately.

The package box should comprise:

Device name	Quantity	Model	Remarks
Power supply	x1	IT6300A/B series	IT6300A/B series include: IT6322A/IT6332A/IT6333A/ IT6322B/IT6332B/IT6333B
Power Cord	x1	IT-E171/IT-E172/ IT-E173/IT-E174	The User may select different power cords based on local outlet specification. For detailed specifications, refer to 1.4 Connecting the Power Cord.
CD	x1	-	It contains User's Manual and Programming Guide.
Ex-factory Test Report	x1	-	It is the test report of the instrument before delivery.



### NOTE

After confirming that package contents are consistent and correct, please appropriately keep package box and related contents. The package requirements should be met when the instrument is returned to factory for repair.

## 1.2 Installation Position

The instrument should be installed at well-ventilated and rational-sized space. Please select appropriate space for installation based on the power supply size.

IT6322A/IT6322B: 214.5mmW\*88.2mmH\*345mmD (W:width H:height D:depth)

IT6332A/IT6333A/IT6332B/IT6333B: 214.7mmW\*88.2mmH\*444.5mmD

Refer to the dimension below:

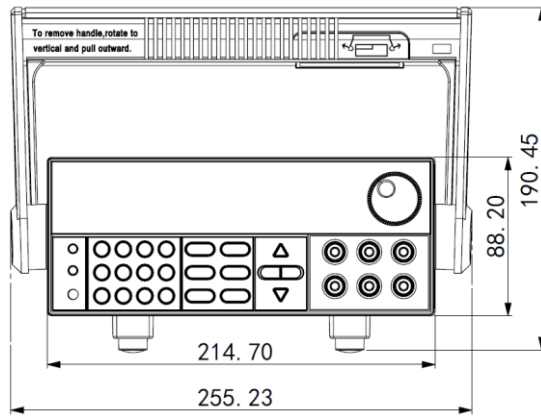

Front view for IT6322A/IT6332A/IT6333A/IT6322B/IT6332B/IT6333B.

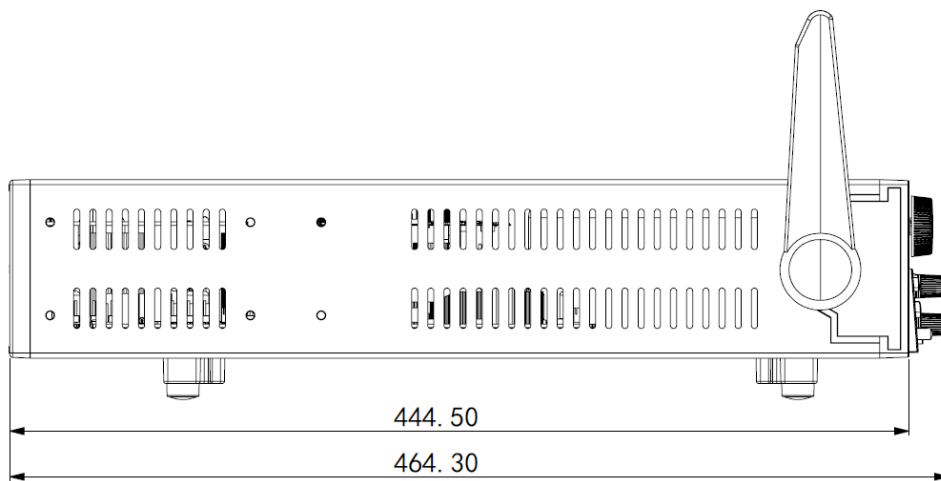

Lateral view for IT6332A/IT6333A/IT6332B/IT6333B.

Unit: millimeter (mm)

IT6322A Model

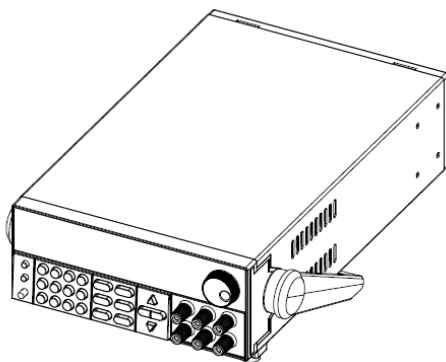

Dimension:  
 Width: 255mm  
 Height: 108.7mm  
 Depth: 374.32

Detailed Dimension Drawing

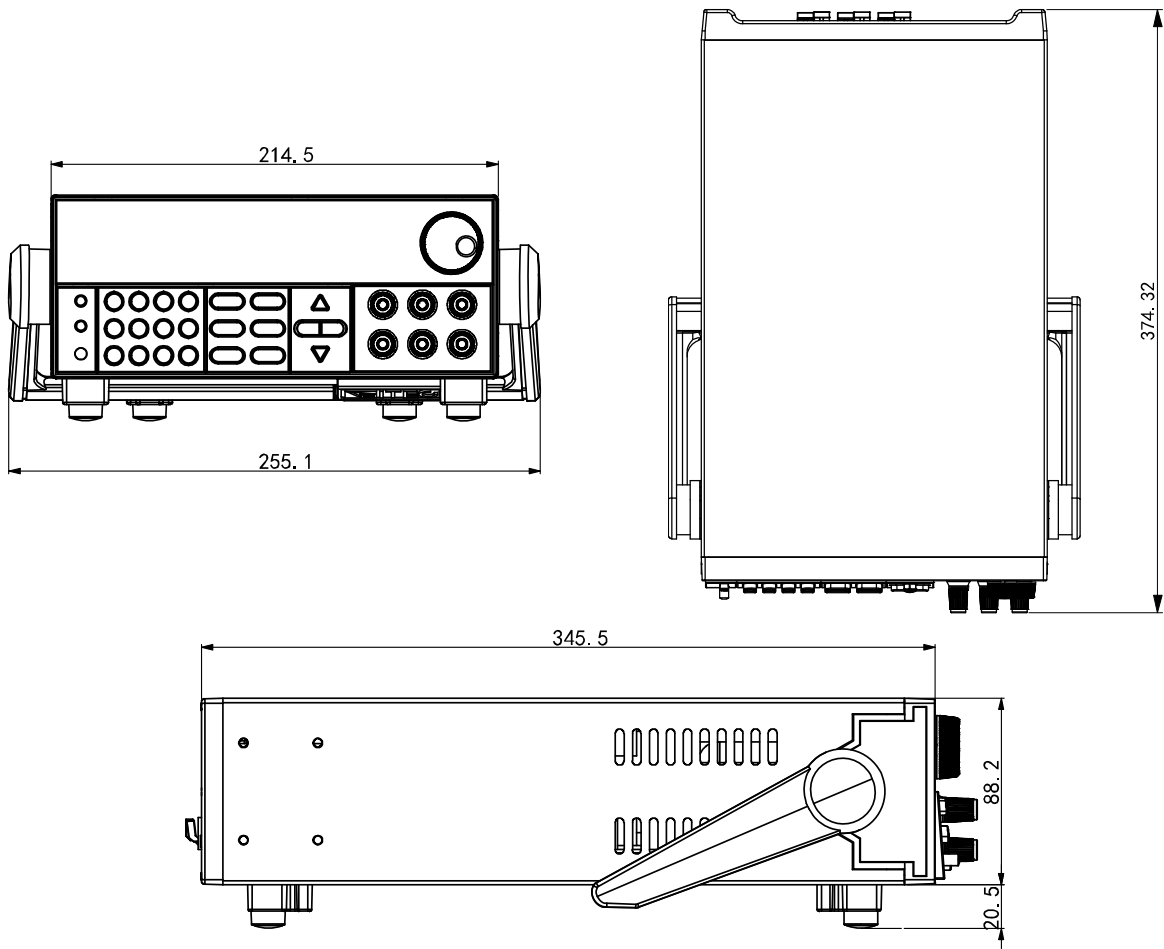

IT6322B Model

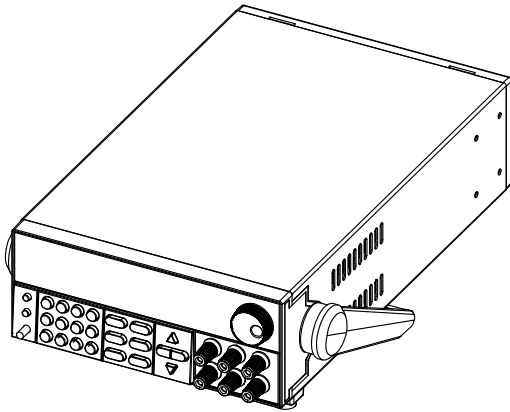

Dimension:

Width: 255mm

Height: 108.7mm

Depth: 365.7mm

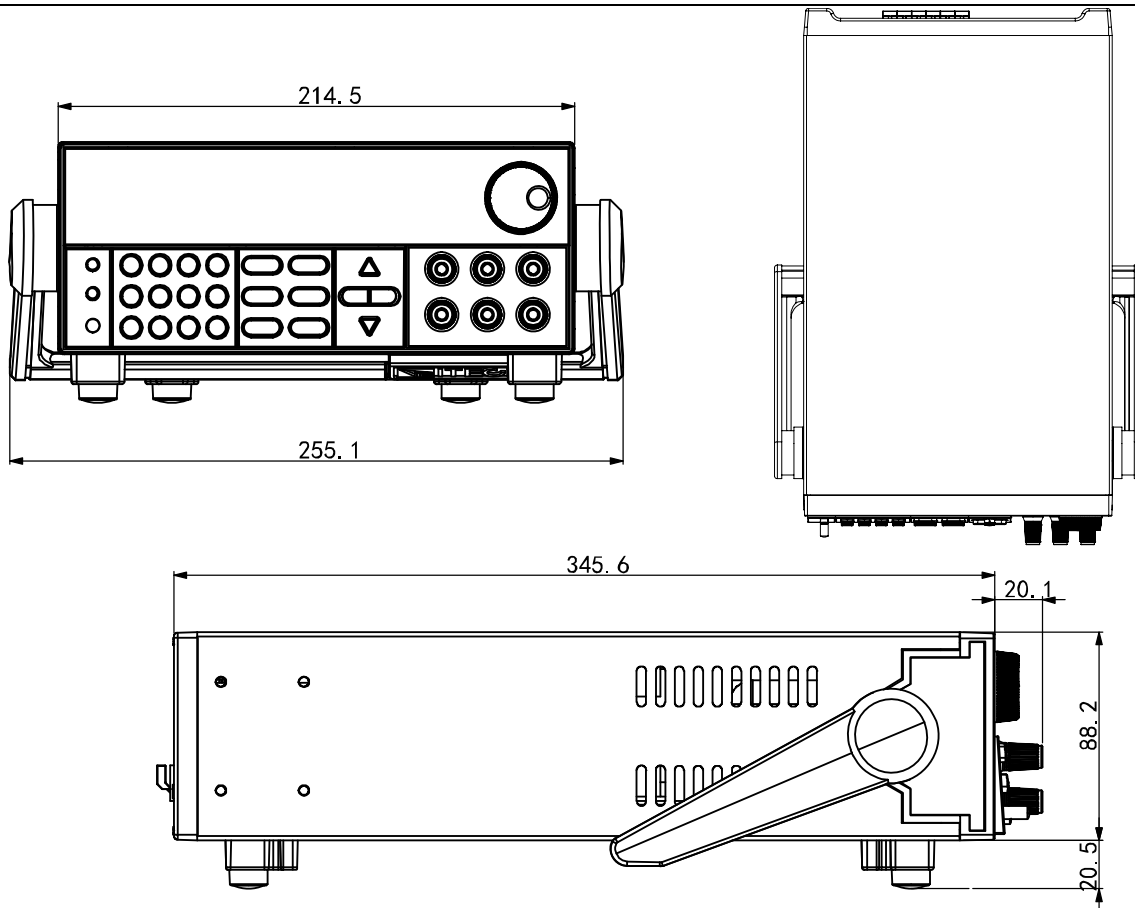
**Detailed Dimension Drawing**

### 1.3 Adjustment of power handle

To adjust the position, grasp the handle by the sides and pull outward. Then rotate the handle to the desired position.

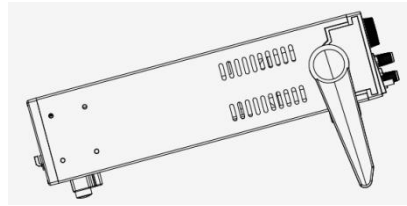
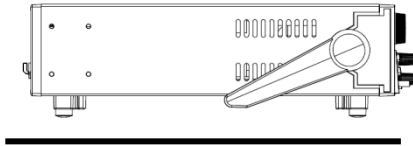

Bench operation

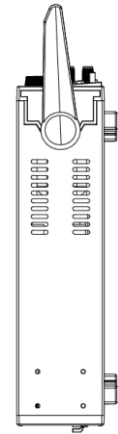

Handle

## 1.4 Connecting the Power Cord

Connect power cord of standard accessories and ensure that the power is under normal power supply.

### AC power input level

Working voltage of IT6300A/B series includes 110V and 220V (which can be selected by the switch at the bottom of load).

AC power input level:

- Option Opt.01: 220VAC  $\pm$  10%, 47 to 63 Hz
- Option Opt.02: 110 VAC  $\pm$  10%, 47 to 63 Hz

### Categories of power lines

Select from the flowing schedule of power cord specifications an appropriate power cord that matches the voltage for the area in which you use the instrument. If the power cord included in the instrument you purchased does not match the voltage, contact the dealer or manufacturer for change.

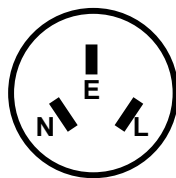

China

IT-E171

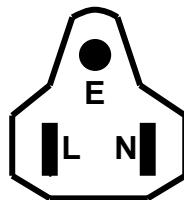

 United States &  
Canada & Japan

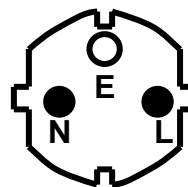
IT-E172

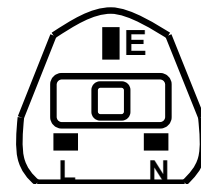

Europe

IT-E173



England

IT-E174

## Chapter2 Quick Start

This chapter introduces the front panel, the rear panel, key functions and VFD display function of the power supply, make sure that you can quickly know the appearance, instruction and the key function before you operate the power supply, Help you make better use of this series of power supply.

### 2.1 Brief Introduction

IT6300A/B series triple output programmable DC power supply, the output voltage or current of each channel can be set from 0 to max rated value.

The triple output power supply provides you with high-resolution, high accuracy and high stability, and supports over voltage, over temperature protection; Provides a serial or parallel mode, used to extend the voltage or current output capacity. Resolution reaches up to 1mV/1mA that it can meet the needs of a variety of applications, and is a great choice for University or R & D department and the manufacturer. The main features and advantages are as follows:

- Triple output voltage, all are adjustable.
- CH1 and CH2 can set to serial/parallel/track mode.
- The voltage and current for the three channels can be displayed at the same time.
- Small size of 1/2 2U
- VFD display
- Function keys with LED light
- Remote measurement function, compensation online pressure drop.
- High accuracy 、 resolution and stability.
- Switch to control the output status.
- Limited voltage and over heat protection.
- Intelligent fan control, energy conservation, noise reduction.
- Built-in RS232/USB/GPIB communication interface.
- Low ripple and low noise
- Shut off memory function
- Can be monitored by computer software.
- Can calibrate through software.
- Memory capacity of 36 groups, for save and recall.
- Can adjust the voltage or current by knob.
- Can adjust the stepping by Left/right arrow button.
- Output timer function (0.1 ~ 99999.9 seconds)

Model Selection Table for IT6300A/B Series:

Model	Channel	Voltage	Current
IT6322A	CH1	30V	3A
	CH2	30V	3A
	CH3	5V	3A

IT6332A	CH1	30V	6A
	CH2	30V	6A
	CH3	5V	3A
IT6333A	CH1	60V	3A
	CH2	60V	3A
	CH3	5V	3A
IT6322B	CH1	30V	3A
	CH2	30V	3A
	CH3	5V	3A
IT6332B	CH1	30V	6A
	CH2	30V	6A
	CH3	5V	3A
IT6333B	CH1	60V	3A
	CH2	60V	3A
	CH3	5V	3A

\*IT6322A/IT6332A/IT6333A has not standard GPIB communication interface.

## 2.2 Introduction to the front panel

The front panel of IT6300A/B series is shown in the next figure.

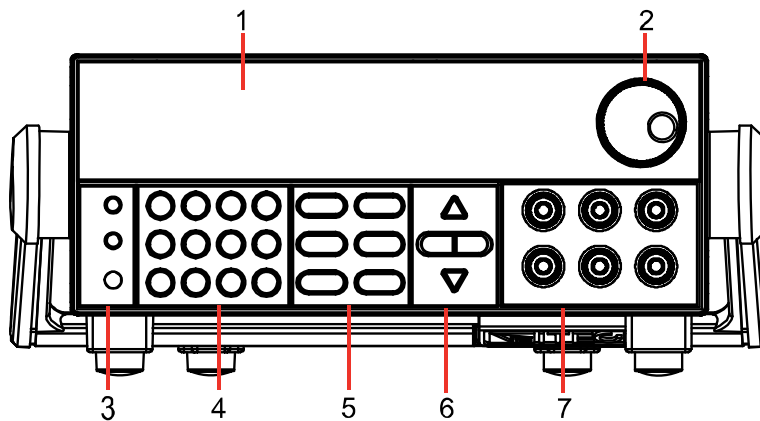









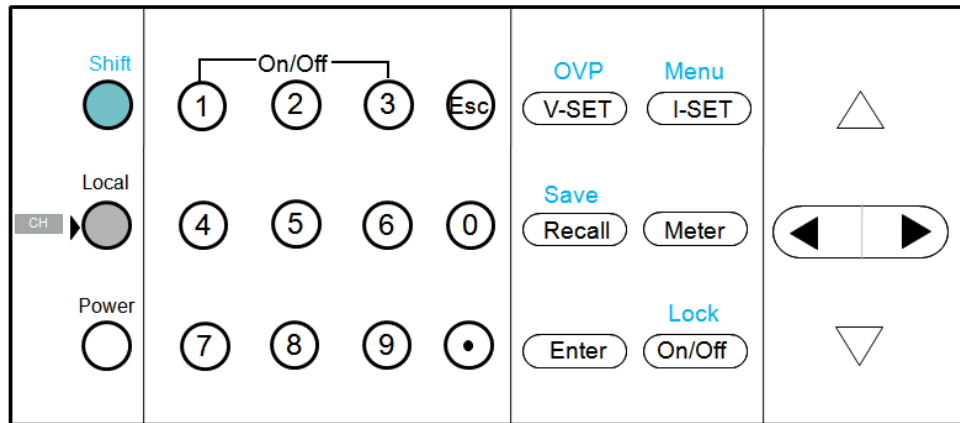



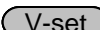
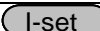

1. VFD display
2. Rotary knob
3. Power switch, Local and Shift key
4. Numeric keys and ESC escape key
5. Function keys
6. Up/Down/Left/Right keys
7. Output terminal

## 2.3 Introduction of the keypad

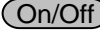



The keypad of IT6300A/B series is shown in the next figure.





Key Symbol	Name & Function
0~9	Numeric keys. Use keys 1~3 to control the output state of the 3 channels which should coordinate with Shift key. Note: In key lock mode, Shift key is not needed.
	Escape from the current setting or menu item.
 (Shift)	Compound key.
 (Local)	Used to switch to local operation mode.
 (Power)	Used to power on/off the DC source.
 /OVP	Used to set the voltage or shift+V-set to set OVP value.
 /Menu	Used to set the current or shift+I-set to enter the menu operation.
 /Save	Save or recall different operating parameters in memory locations.
	Switch the display between setting value and actual value.
	Enter button to confirm the selection.
 /Lock	Used to control the output state of all channels or Shift+On/Off to lock the front keys.
	Right/Left key, use to move the cursor or scroll through the menu items.
	Up/down key, used to increase or decrease the setting value.
 (Shift)+1,  (Shift)+2,  (Shift)+3	Used to turn on the output of corresponding channel no matter in menu operation or Meter state.

## 2.4 Introduction of indicators on the screen

<b>C</b>	In constant current mode.
<b>V</b>	In constant voltage mode.
	Keyboard operation for the lock mode.
	Open the remote sense function.
	Indicates the shift button is pressed.
	Indicates the channel currently selected.
<b>T</b>	Enable tracking mode.

## 2.5 Introduction to the rear panel

The rear panel of IT6322B/IT6332B/IT6333B is shown in the next figure.

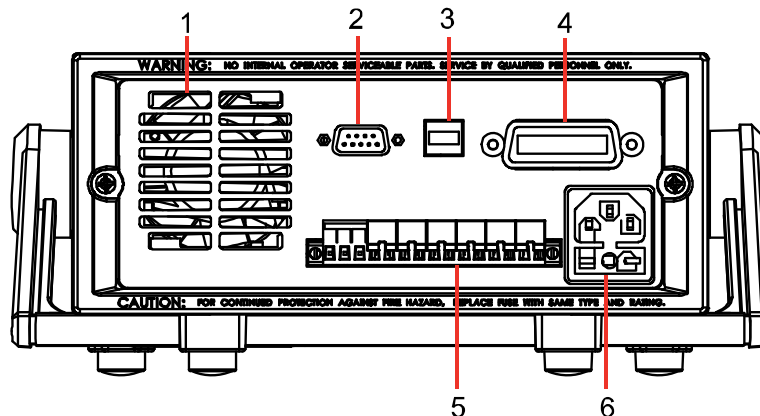

The rear panel of IT6322A/IT6332A/IT6333A is shown in the next figure.

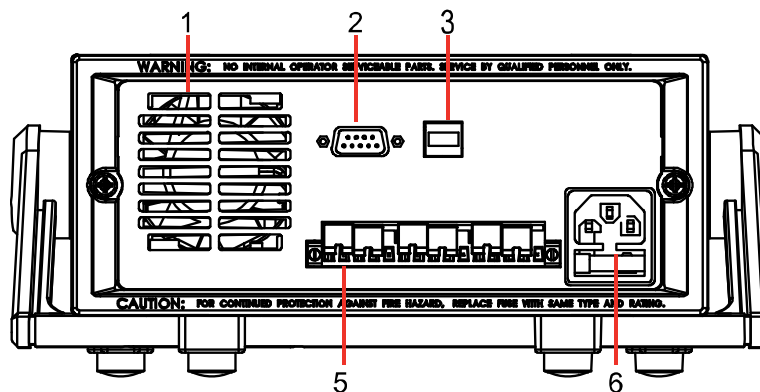

1. Cooling window
2. RS232 communication interface
3. USB communication interface
4. GPIB communication interface
5. Remote measurement terminal
6. 110V/220V AC power selection switch and Fuse

## 2.6 Power-on selftest

A successful selftest indicates that the purchased power product meets delivery standards and is available for normal usage.

Before operation, please confirm that you have fully understood the safety instructions.

### WARNING

- To avoid burning out, be sure to confirm that power voltage matches with supply voltage.
- Be sure to connect the main power socket to the power outlet of protective grounding. Do not use terminal board without protective grounding. Before operation, be sure that the power supply is well grounded.
- To avoid burning out, pay attention to marks of positive and negative polarities before wiring.

### Selftest steps

Normal selftest procedures:

1. Correctly connect the power cord. Press **Power** key to start up.
2. After selftest, VFD display information as follows, the first row displays the voltage, the second row displays the output state or the current. From left to right, as the first, second, third channel voltage current display area.

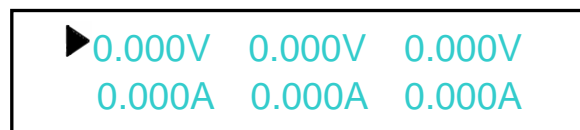

▶ 0.000V 0.000V 0.000V  
0.000A 0.000A 0.000A



#### NOTE

The figure above is configuration menu (Config) for the factory set up on display, the different Out State and Out Param setting in the menu will affect on the final state of the display.

### Error Information References

The following error information may occur when an error occurs during Power On self-test:

- If the EEPROM was damaged, the VFD will display “EEPROM Fail”.
- If the latest operation state of the power supply was lost, then the VFD will display “System Lost”.
- If send channel data, the channel response failure, the VFD display the tooltip information “Model Fail”.
- If calibration data read failure, the VFD display the tooltip information “Cal Lost”.
- If the channel to send data loss, channel initialization failed, the VFD

display the tooltip information “Model Lost”.

- If the factory calibration data in EEPROM is lost, and then the VFD will display “FACT LOST”.

### Exception handling

If the power supply can not start normally, please check and take measures by reference to steps below.

1. Check whether the power cord is correctly connected and confirm whether the power supply is powered.

Correct wiring of power cord => 2

Incorrect wiring of power cord => Re-connect the power cord and check whether the exception is removed.

2. Check whether the power in On. Power key is under “I” On status.

Yes => 3

No => Please check the Power key to start power and check whether the exception is removed.

3. Check whether the fuse of power supply is burned out.

If yes, change fuse. Detailed steps:

- 1) Pull out power line and take out the fuse box at power line jack with a small screw driver. As shown below.

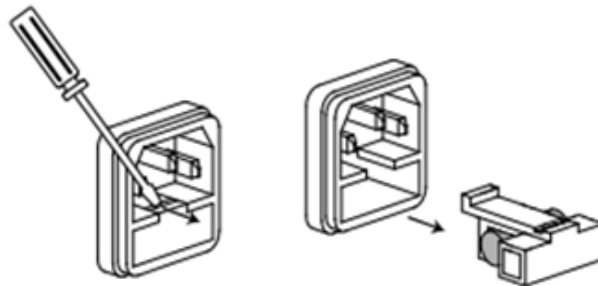

- 2) If the fuse is fused, please change fuse of same specification based on machine model. See the table below for matching information of fuse and machine model.

Products	Specification (220VAC)	Specification (110VAC)
IT6322A/ IT6322B	3.15A T250V	6.30A T250V
IT6332A/ IT6332B	5A T250V	10A T250V
IT6333A/ IT6333B	5A T250V	10A T250V

- 3) After replacement, install the fuse box back to original position, as shown below.

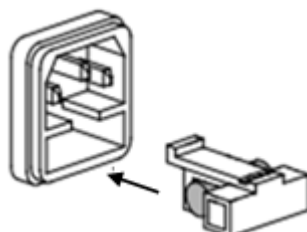

----End

## 2.7 Output verification

The following procedure verify that the power supply outputs the correct voltage and current levels and properly responds to entries from the front panel.

### Voltage Output Check

The following steps verify basic voltage function without load.

1. Press Power key to turn on the power supply.
2. Press **On/Off** key to enable the output.
3. Set the voltage value.

Adjust the voltage, then press **Meter** to lit the key (indicates it is in the METER mode), make sure that the set value and output value are same, and if the current displayed on the VFD is nearly 0A.

4. Make sure the voltage can be adjusted from zero to the maximum rated value.
5. Check the other two channels by the same method.



#### NOTE

when **Meter** key is gray, the power supply is in SET mode, then the VFD displays the set voltage and current; when the key is lit, then the power supply is in METER mode, the actual voltage and current display on the VFD. When the output is OFF, the "OFF" indicate will display at the current display area.

----End

### Current output Check

The following steps check the basic current functionality by shorting the power supply's output.

1. Press Power key to turn on the power supply.
2. Press **On/Off** to disable the output, ensure the output is OFF.
3. Connect a short across (+) and (-) output terminals with an insulated test lead, use a wire sufficient to handle the maximum current.
4. Adjust the voltage value to 1V.
5. Press **On/Off** to enable the output.
6. Adjust the current.

Set some different current values, in METER mode, check whether the voltage value on VFD is near 0v, and the current on it is close to the value you set.









7. Make sure that the current can be adjusted from 0 to full rated value.
8. Disable the output and then remove the short wire.
9. Check the other two channels by the same method.

----End

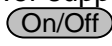
## Chapter3 Function and Features

So far we have covered the quick start chapter which briefly introduced the front panel operation and how to check basic voltage and current functionality. This chapter describes in detail how to operate the instrument manually via the front-panel keys.

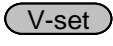
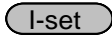
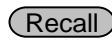
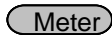
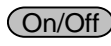

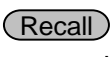

### 3.1 Front-panel Operation Overview

- The power supply is shipped from the factory ready for front-panel operation mode. At power-on, the power supply will automatically enter the front-panel operation mode and the instrument can be controlled via the front panel keys and knob.
- The power supply enters remote mode as soon as a valid remote command is received via the communication connector in the rear. Switching to remote mode does not impact the supply's output parameters. In remote mode, front-panel operation is disabled. Only Meter and Local buttons are enabled. If the power supply is in remote mode, and the  (Local) key is enabled, you can revert to manual mode by pressing the  (Local) key.
- The power supply is in Set mode when it is powered on. In this mode, the VFD will display the setting voltage and current.
- The output of power supply can be enabled/disabled from the front panel by pressing the  button. When turn on the output, the VFD will display the state and voltage/current of each channel. "CC" represents constant current mode. "CV" represents constant voltage mode. **When output is in OFF mode, VFD will have no any indicators of CC or CV.**
- The VFD also displays operation states or error information. "  " means the power supply is in remote mode. When front-panel keys are locked,  button will be lit. "  " means the power supply keyboard locked. For more details, please refer to chapter of "Descriptions about VFD marks".
- If the power supply is in set mode, you can modify parameters using the knob. If the power supply is in menu operation, the knob is used for menu selection.
- When , , ,  or  buttons are lit, means they are selected and under corresponding state now. If pressing  (Shift)+  (Save),  button will keep flickering and waiting for a number to be entered to specify the memory location.
- When V-SET/I-SET buttons are lit, following conditions will enable the cursor to display again.
  - Pressing V-SET/I-SET buttons again.
  - Adjusting the knob.
  - Pressing direction buttons.

**NOTE**

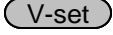
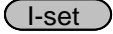
If there is any operation on front panel within 5S, the cursor will disappear automatically. You can also disable the cursor by pressing ESC button. When VFD displays cursor, you can modify the parameters by adjusting knob or up/down keys, or move the cursor by right/left keys.



**Details about key buttons' state:**

	When button is lit, means you can set voltage. When button keeps flickering, means in OVP setting mode.
	When button is lit, means in current setting mode.
	When button is lit, means in recall mode. When button keeps flickering, means in save mode and waiting for a number to be entered to specify the memory location.
	When button is lit, means current VFD displays actual voltage and current.
	When button is lit, means at least one channel output is on. Or all channels are in OFF mode.

**NOTE**

 ,  ,  buttons will not be lit at the same time.

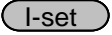
## 3.2 Menu Description

Press  (Shift)+  (Menu) to indicate operation mode. View the menu on the VFD, and use the right/left key to change the setup, and up/down key to scroll through the complete menu items. Press  to enter the selected menu function. Press  button to return to the previous menu. When the item keeps flickering indicates it is selected currently.

Power Menu...			
Config	Configuration Menu		
	Configuration Menu...	Configuration Menu	
Out State	Power Out State Set	Power supply power on output state Settings	
	Off	all along OFF	
	Keep	Keep the last time state before the shutdown	
Out Param	Power Out Param Set	Set up the related parameters when power on	
	Reset	default	
	Keep	Restore the last time parameters	
Knob	Knob Function Set	Pulsating knob function Settings	
	Unlock	Pulsating knob function open	
	Lock	Pulsating knob function closed	
Buzzer	Power Key Beeper Set	Key sound establishment	

		Off	Key sound closed		
		On	Key sound open		
	Communication	Communication Select	Communication interface choice		
		RS232	Choose RS232 communication interface		
			RS232 Communication Set	RS232 communication set	
				4800, 8, N, 1, Single	
				9600 O Mux	
				19200 E	
				38400	
				57600	
		115200			
		GPIB	Choose GPIB communication interface		
	Communication Address		GPIB communications address		
	Address=15 (0~31)				
	USB	Choose USB communication interface			
Ext Port	Ext Port settings...	External interface Settings			
	None	None			
Memory Group	Select Memory Group	Memory group set			
	GRP1	Group 1			
	GRP2	Group 2			
	GRP3	Group 3			
	GRP4	Group 4			
Command	SCPI Version	SCPI version select			
	Select...				
	ITECH	ITECH SCPI command			
	EXT1	Extended SCPI command 1			
	EXT2	Extended SCPI command 2			
Return Meter	Auto Return to Meter State	Auto Return to Meter State			
	Off	Function close			
	Wait 5 Sec	The front panel display will change from setting to meter state automatically after 5s.			
Reset	Reset Menu Default	restore the factory setting			
	No	Cancel			
	Yes	Enter			
Exit	Exit the config menu				
System	System Menu				
	Channel Sel ...	Channel Select			
	CH1	System Menu...			
		Max volt	Max voltage Set		
			Max Volt=31.000V		



	Out timer	Out Timer State Set		
		Disable		
		Enable		
	Exit			
	CH2	System Menu...		
		Max Volt	Max Voltage Set	
			Max Volt=31.000V	
		Out Timer	Out Timer State Set	
			Disable	
			Enable	
		Exit		
	CH3	System Menu...		
		Max Volt	Max Voltage Set	
			Max Volt=6.000v	
		Out timer	Out Timer State Set	
Disable				
Enable				
Exit				
Comb	Power Combine Set...			
	Off			
	Series	Series Choose...	Select serial connect mode	
		CH1+CH2	Connect CH1 and CH2 in serial	
	Parallel	Parallel Choose...	Select parallel connect mode	
		CH1+CH2	Connect CH1 and CH2 in parallel	
		CH2+CH3	Connect CH2 and CH3 in parallel	
		ALL	Connect three channels in parallel	
	Track	Track Choose...	Enable tracking function	
		CH1+CH2	Connect CH1 and CH2 in track	
		CH2+CH3	Connect CH2 and CH3 in track	
		ALL	Connect three channels in track	
Exit	Exit the system menu			

**NOTE**

In the menu, right/left arrow keys and rotary knob used for flow around the menu, change the options,  Used to identify the current menu commands or into the next layer menu.

Press  can exit menu or enter a layer menu.

## Out State

This parameter sets the output On/Off state at power up. If you select “**Keep**”, the power supply will save the output state prior to power down and revert to that state at power up. If you select “**Off**”, the output state is always

“OFF” when the power supply is turned on. The recommend setting is “OFF”.

## Out Param

This menu item is used for set up power whether save the last output parameters. If you select “Keep”, the power save the last time before the shutdown of the output parameters. The next time after startup power output parameter is still the last output parameters. If you select “Reset”, the power output for factory default output parameters.

## Knob

This item enables (“On”) or disables (“Off”) the knob.

## Buzzer

This item turns the beep sound for key presses “On” or “Off”.

## Communication

This item set the communication mode, optional communication interfaces are RS232, GPIB, USB.

- **RS232 Communication Set**

This item configures the baud rate for serial communication. Possible values are 4800,9600,19200,38400,57600,115200. When operating the power supply in remote mode, make sure that you configure identical baud rate settings for the power supply and the computer.

Optional settings of parity bit for serial communication are NONE, ODD and EVEN. Default setting is NONE.

- **GPIB**

This item set the communication address for GPIB interface. Available range is 0-31.

- **USB**

Select communication mode via USB interface.

## Memory Group

You can store up to 36 different operating states in a nonvolatile memory space. All saved parameters are divided into four groups. They are Grp1, Grp2, Grp3 and Grp4. Each group can save 9 different operating states (1~9).

## Command

This item set the communication protocol. Possible settings are SCPI, EXT1 and EXT2. Default setting is SCPI.

## Return Meter

This item enable (“Wait5Sec”) or disable (OFF) the function to turn back to meter state automatically. When select “Wait5Sec”, the display on front panel will automatically change to meter state under the condition of no operation within 5S.

## Reset

If you enter this menu and select “YES”, all parameters will be set to their default values.

## Exit

Escape the menu.

## System

This item set the max voltage and out timer of each channel. Choose one channel and set the parameters.

## Max Volt

The max voltage you set should be within the range of 0V to the maximum rated voltage. You can edit this value using the  $\Delta$ ,  $\nabla$  keys or via numerical key pad followed by **Enter**. The default setting is the maximum rated voltage for each channel.

## Out Timer

This item sets the output timer for each channel. The range is 0.1~99999.9S. If you enable this function, and the output state of all channels is on, the timer will start counting down immediately. Once the timer expires (count down from set value to zero) the output of the assigned channel will turn off. To disable the timer, set the output time to zero. Default setting is 0 seconds.

## Comb

This item configures the instrument connection mode.

- **Off**

“Off” means that each channel operates independently. When set successfully, front panel will display “Remove success!”

- **Series (Series mode)**

This function configures the instrument for series operation of CH1 and CH2. Press **Enter** button to confirm your set. And press **Esc** to quit the operation.

When enable series connection mode, the front panel will indicate “Series success!” and escape this screen after 2S.

Front display as follows in condition of output off and meter state.

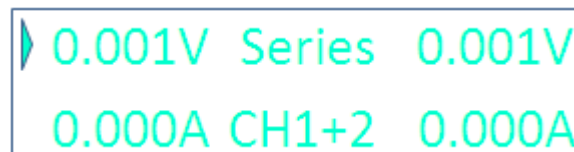

The screenshot shows the instrument's front display with the following text:
   
▶ 0.001V Series 0.001V
   
0.000A CH1+2 0.000A

- **Parallel (Parallel mode)**

This function configures the instrument for parallel operations of three channels. Possible combination mode are CH1+CH2, CH2+CH3, ALL.

Press **Enter** button to confirm your set. And press **Esc** to quit the operation.

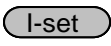
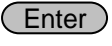
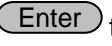

Take “CH2+CH3” as an example, press  (Shift) +  (Menu) -----Select “ Comb” and press  to confirm.-----select “ CH2+CH3” item and press  to confirm.The front panel will indicate “Parallel Success!” and escape this screen after 2S.

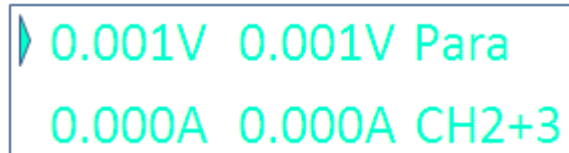
Front display as follows in condition of output off and meter state.



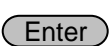

- **Track (sync output setting)**

This function configures the instrument for tracking operations of three channels. Possible combination mode are CH1+CH2,CH2+CH3,ALL.

Press  button to confirm your set.And press  to quit the operation.

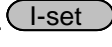
In tracking mode,once the parameters of any one channel are changed,other channels will change proportionally.

For example, set voltage and current of CH1 and CH2 as follows, CH1: 4V, 1A; CH2: 8V, 2A. Press  (Shift) +  (Menu) into Menu, and press  to select Comb, VFD will display as follows:

**CH1+CH2    CH2+CH3    ALL**

Select “CH1+CH2” and press  to confirm. The VFD will display “Track Set Success!” and escape this screen after 2S..

Front display as follows in condition of output off and meter state.

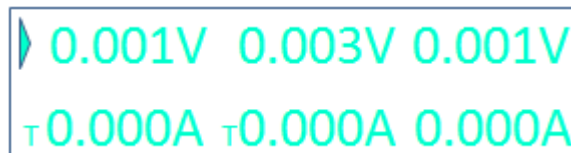

For example: In setting status, if voltage of CH1 is set as 2V, voltage of CH2 will automatically change to 4V proportionally.



**NOTE**

Tacking function is disabled to the channel with 0V or 0A setting. In the former example,if CH2 setting is 0V or 0A, then when CH1 voltage is adjusted to 2V,CH2 will remain unchanged.

**Parameters in Serial, Parallel or Tracking mode**

Maximum voltage

Operate “CH1+CH2” in series, the max voltage is 62V the sum of the max voltage of CH1 and CH2.

Operate “CH1+CH2” in parallel, the max voltage is the smallest max voltage of the two channels. It is 31V.

Operate “CH2+CH3” in parallel, the max voltage is the smallest max voltage of the two channels, it is 6V.

Operate “CH1+CH2+CH3” in parallel, the max voltage is the smallest max voltage of the three channels. It is 6V.

In tracking mode, the max voltage is 31V.

In serial, parallel and tracking mode, the out timer function will be disabled.

In serial, parallel and tracking mode, the Save/Recall function will be disabled.



#### NOTE

When changed to serial, parallel or tracking mode, all channels will be OFF and voltage will be reset to 0V. The channels configured to serial, parallel or tracking mode will be add a label of “[ ]” in the display.

## Power Information

Press  (Shift) + , VFD will display power information; the information includes the following parts:

### Power Model

Display the model of power supply: IT63XX

### Soft Version

Firmware version of power supply: Ver=1.XX-1.XX



### Power SN

Display the serial number of the power supply: SN:XXXXXXXXXXXXXXXXXXXX



### Calibration information

Display calibration information: 2005-8-26 17:46:13

### Error Information



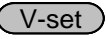
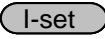





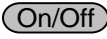
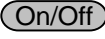



If error, press  (Shift) + , VFD will display error information, press any key to display the next error message, If not, then continue to display information on above(model, the software version, serial number, etc.) Error message will be cleared in the display, but fault still exist.

## 3.3 Channel Operation

When  or  button is lit, press  (Local) key can switch between the three channels.

## 3.4 OUT ON/OFF

Pressing  button toggles the output state of all 3 channels of the power supply. If the output state is ON, press it to turn the output state to OFF. While the output state is OFF, press  and the power supply output will turn ON.

To control channels individually, press  (Shift) + ,  (Shift) + ,  (Shift) +  corresponding to each channel.  (Shift) +  controls the output state of the first channel,  (Shift) +  controls the output state of the second channel,  (Shift) +  controls the output state of the third channel.

When the power supply is in remote mode, you can set the output state by sending SCPI command (OUTPUT: ON | OFF). The output state operation does not affect any other parameter.



NOTE

The **On/Off** key controls the output state of all 3 channels simultaneously. If you want to control the output state of individual channels, use the number keys 1-3 with shift button.

## 3.5 Timer operation

If the “Out timer” is enabled for any channel in the menu, after the time set, the specified channel of the power supply will automatically switch to output off state. Please refer to Out Timer of chapter 3.2.

## 3.6 Set Voltage

- **Solution 1:** press **Local** to select channel, press **V-set** then enter a numerical value followed by **Enter**.
- **Solution 2:** Press **V-set**, then press **▶** **◀** to move the cursor position and adjust the voltage value using the knob. Press **Esc** or **Enter** to exit.
- **Solution 3:** Press **V-set**, then press **▶** **◀** to move the cursor position and adjust the voltage value using **▲** **▼**. Press **Esc** or **Enter** to exit.



NOTE



When output in OFF mode and **Meter** button is dark, rotary knob and up/down keys can't be used to adjust voltage and current. If rotary knob is enabled, then adjusting it will real-time change the current output setup without pressing **Enter** to confirm.

## 3.7 Current Operation

- **Solution 1:** press **Local** to select channel, press **I-set** then enter a numerical value followed by **Enter**.
- **Solution 2:** Press **I-set**, then press **▶** **◀** to move the cursor position and adjust the current value using the knob. Press **Esc** or **Enter** to exit.
- **Solution 3:** Press **I-set**, then press **▶** **◀** to move the cursor position and adjust the current value using **▲** **▼**. Press **Esc** or **Enter** to exit.

## 3.8 Save and Recall Operation

You can store up to 36 different operating states in memory locations 1 through 36. They are divided to four groups, each group includes nine different setups. Each operating state includes a constant voltage value, constant current value, maximum output voltage.

Press  (Shift) +  (Save) followed by a number key to save the current operating state to non volatile memory.

Press  + number 1 to 9 to recall operating state assigned to this location.

You can also use the SCPI command(\*SAV、\*RCL) to save and recall.



When Save operation is done, there will be a corresponding information to indicate the successful or failed operation. While for Recall operation, only information to indicate failed recall.











### NOTE

The power supply doesn't support Save/Recall operation when in serial/parallel or tracking mode. If in serial/parallel mode and do Save/Recall operation, the VFD will display INV OPER (invalid Operation) to remind the user of a wrong operation. If parameters want to be recalled do not exist, the current value position on VFD will display -----, and then resume after 2S.



## 3.9 Key Lock Set

Press  (Shift) +  (Lock) can lock the front panel keys and label “” will be lit on the lower left corner

In key lock mode, all keys are disabled, except , , , , ,  (Local) and  +  keys.

## 3.10 Protections

### OVP operation

Select the channel-----press  (Shift)+  (OVP)-----select “ON” and continue to set the OVP value. After set successfully, when the actual voltage is higher than OVP value, then VFD will display “OVER VOLT”.

### Over Temperature Protection

If the internal temperature of the power supply exceeds 80°C, the instrument will protect itself by automatically turning power OFF. When this happens you will hear a buzzer and the display will indicate the following:

Over Temperature...

### 3.11 Remote sense function

Remote voltage sensing is used to maintain good regulation at the load and reduce the degradation of regulation that would occur due to the voltage drop in the leads between the power supply and the load. By connecting the supply for remote voltage sensing, voltage is sensed at the load rather than at the supply's output terminals. This will allow the supply to automatically compensate for the voltage drop in the load leads and improve regulation.

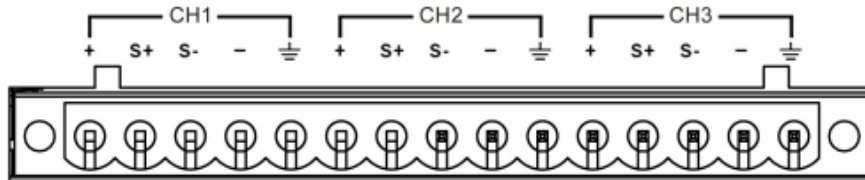

**+, -:** output terminal, the same as front pane output terminals.

**S+,S-:** Remote sensing terminal.

#### Disable remote sense function:

1. Use the standard shorting clip which has been installed before leave the factory. Or you can also use wires to short “S+” and “+”, “S-” and “-”.
2. Connect output “+” and “-” to the load input terminals “+” and “-”.

#### Enable remote sense function:

1. Remove the shorting clip between “S+” and “+”, “S-” and “-”.
2. Connect output “+” and “-”(front panel) to the load input terminals “+” and “-”.
3. Connect “S+” to “+” of the load, ”S-” to the “-” of the load.



NOTE

To ensure the system stability, please use twisted-pair cables between sense terminal and load.

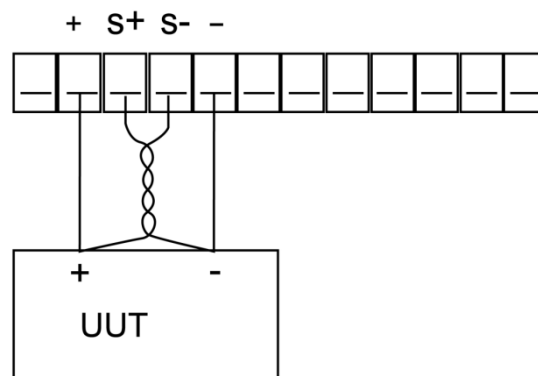



## Chapter4 Technical Specifications

### 4.1 Major technical parameters

IT6322A/IT6322B				
Parameters		CH1	CH2	CH3
Rated values (0 °C - 40 °C)	Voltage	0~30V	0~30V	0~5V
	Voltage limiting	0~31V	0~31V	0~6V
	Current	0~3A	0~3A	0~3A
	Power	90W	90W	15W
Load regulation (%of output + offset)	Voltage	≤0.01%+3mV		
	Current	≤0.1%+3mA		
Line regulation (%of output + offset)	Voltage	≤0.01%+3mV		
	Current	≤0.1%+3mA		
Setup resolution	Voltage	1mV		
	Current	1mA		
Read-back resolution	Voltage	1mV		
	Current	1mA		
Setup accuracy (Within 12 months) (25 °C ± 5 °C) (%of output + offset)	Voltage	≤0.03%+10mV		
	Current	≤0.1%+5mA		
Read-back accuracy (25 °C ± 5 °C) (%of output + offset)	Voltage	≤0.03%+10mV		
	Current	≤0.1%+5mA		
Ripple and noise (20Hz-20MHz)	Voltage (Vp-p)	≤3mVp-p		
	Voltage (rms)	≤1mVrms		
	Current	≤3mA <sub>rms</sub>		
Output Temp. coefficient (0 °C ~ 40 °C) (%of output + offset)	Voltage	≤0.03%+10mV		
	Current	≤0.1%+5mA		
Read-back Temp. coefficient (%of output + offset)	Voltage	≤0.03%+10mV		
	Current	≤0.1%+5mA		
Parallel setup accuracy	Voltage	≤0.02%+5mV		
	Current	≤0.1%+20mA		
Memory	Save/recall	36 groups		
Timer	Function	Output timer		
	Time set	0.1~99999.9 second		
	Resolution	0.1 second		
Working temperature		0-40°C		
Dimension (mm)	WxHxD	214.5mmx88.2mmx354.6mm		

IT6332A/IT6332B				
Parameters		CH1	CH2	CH3
<b>Rated values</b> (0 °C - 40 °C)	Voltage	0-30V	0-30V	0-5V
	Voltage limiting	31V	31V	6V
	Current	0-6A	0-6A	0-3A
	Power	180W	180W	15W
<b>Load regulation</b> (% of output + offset)	Voltage	≤0.01%+3mV	≤0.01%+3mV	≤0.01%+3mV
	Current	≤0.01%+3mA	≤0.01%+3mA	≤0.01%+3mA
<b>Line regulation</b> (% of output + offset)	Voltage	≤0.01%+3mV	≤0.01%+3mV	≤0.01%+3mV
	Current	≤0.01%+3mA	≤0.01%+3mA	≤0.01%+3mA
<b>Setup resolution</b>	Voltage	1mV	1mV	1mV
	Current	1mA	1mA	1mA
<b>Read-back resolution</b>	Voltage	1mV	1mV	1mV
	Current	1mA	1mA	1mA
<b>Setup accuracy</b> (Within 12 months) (25°C ± 5 °C) (% of output + offset)	Voltage	≤0.03%+10mV	≤0.03%+10mV	≤0.03%+10mV
	Current	≤0.1%+8mA	≤0.1%+8mA	≤0.1%+5mA
<b>Read-back accuracy</b> (25 °C ± 5 °C) (% of output + offset)	Voltage	≤0.03%+10mV	≤0.03%+10mV	≤0.03%+10mV
	Current	≤0.1%+8mA	≤0.1%+8mA	≤0.1%+5mA
<b>Ripple and noise</b> (20Hz-20MHz)	Voltage (Vp-p)	≤4mVp-p	≤4mVp-p	≤3mVp-p
	Voltage (rms)	≤1mVrms	≤1mVrms	≤1mVrms
	Current (rms)	≤5mA <sub>rms</sub>	≤5mA <sub>rms</sub>	≤4mA <sub>rms</sub>
<b>Output Temp. coefficient</b> (0 °C ~ 40 °C) (% of output + offset)	Voltage	≤0.03%+10mV	≤0.03%+10mV	≤0.03%+10mV
	Current	≤0.1%+5mA	≤0.1%+5mA	≤0.1%+5mA
<b>Read-back Temp. coefficient</b> (% of output + offset)	Voltage	≤0.03%+10mV		
	Current	≤0.1%+5mA		
<b>Parallel setup accuracy</b>	Voltage	≤0.02%+5mV		
	Current	≤0.1%+30mA		
<b>Memory</b>	Save/recall	36 groups		
<b>Timer</b>	Function	Output timer		
	Time set	0.1-99999.9 second		
	Resolution	0.1 second		
<b>Working temperature</b>		0-40°C		
<b>Dimension (mm)</b>	W×H×D	214.5mm×88.2mm×453.1mm		
<b>Weight (net)</b>		15Kg		

IT6333A/IT6333B				
Parameters		CH1	CH2	CH3
Rated values (0 °C - 40 °C)	Voltage	0-60V	0-60V	0-5V
	Voltage limiting	61V	61V	6V
	Current	0-3A	0-3A	0-3A
	Power	180W	180W	15W
Load regulation (% of output + offset)	Voltage	≤0.01%+3mV	≤0.01%+3mV	≤0.01%+3mV
	Current	≤0.01%+3mA	≤0.01%+3mA	≤0.01%+3mA
Line regulation (% of output + offset)	Voltage	≤0.01%+3mV	≤0.01%+3mV	≤0.01%+3mV
	Current	≤0.01%+3mA	≤0.01%+3mA	≤0.01%+3mA
Setup resolution	Voltage	1mV	1mV	1mV
	Current	1mA	1mA	1mA
Read-back resolution	Voltage	1mV	1mV	1mV
	Current	1mA	1mA	1mA
Setup accuracy (Within 12 months) (25°C ± 5 °C) (% of output + offset)	Voltage	≤0.03%+10mV	≤0.03%+10mV	≤0.03%+10mV
	Current	≤0.1%+5mA	≤0.1%+5mA	≤0.1%+5mA
Read-back accuracy (25 °C ± 5 °C) (% of output + offset)	Voltage	≤0.03%+10mV	≤0.03%+10mV	≤0.03%+10mV
	Current	≤0.1%+5mA	≤0.1%+5mA	≤0.1%+5mA
Ripple and noise (20Hz-20MHz)	Voltage (Vp-p)	≤4mVp-p	≤4mVp-p	≤3mVp-p
	Voltage (rms)	≤1mVrms	≤1mVrms	≤1mVrms
	Current (rms)	≤4mA rms	≤4mA rms	≤4mA rms
Output Temp. coefficient (0 °C ~ 40 °C) (% of output + offset)	Voltage	≤0.03%+10mV	≤0.03%+10mV	≤0.03%+10mV
	Current	≤0.1%+5mA	≤0.1%+5mA	≤0.1%+5mA
Read-back Temp. coefficient (% of output + offset)	Voltage	≤0.03%+10mV		
	Current	≤0.1%+5mA		
Series setup resolution	Voltage	0-99V	--- 1mV	--
		100-120V	--- 10mV	
	Current	1mA		--
Series Read-back resolution	Voltage	0-99V	--- 1mV	--
		100-120V	--- 10mV	
	Current	1mA		--
Parallel setup accuracy	Voltage	≤0.02%+10mV		
	Current	≤0.1%+30mA		
Memory	Save/recall	36 groups		
Timer	Function	Output timer		
	Time set	0.1-99999.9 second		

	Resolution	0.1 second
<b>Working temperature</b>		0-40°C
<b>Dimension (mm)</b>	W×H×D	214.5mm×88.2mm×453.1mm
<b>Weight (net)</b>		15Kg

\*The above specifications may be subject to change without prior notice.

## Chapter5 Communication with PC

IT6322B/IT6332B/IT6333B Standard configuration have three communication interface: RS232 , USB and GPIB, IT6322A/IT6332A/IT6333A Standard configuration have two communication interface: RS232 and USB. The user can choose any one to realize the communication with the computer. The following content can help you understanding how to through the computer control power supply output.

### 5.1 RS232 interface

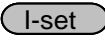
The power rear panel has a DB9 needle mouth. Using both for the COM (DB9) cable connect computer. Press  (Shift) +  (Menu) , setting menu of configuration the same as the computer configuration before Activation connection. RS-232 interface can use all of the SCPI command to programming.



#### NOTE

In the procedure, the RS-232 must be set consistently with the front panel system menu set. If

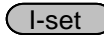
you want to change, please press  (Shift)+  (Menu) and access to menu to change.

#### RS-232 data format

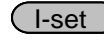
RS-232 data is a start bit and a stop bit 10 words. Start bit and the number of stop bits can not be edit. However, press  (Shift)+  (Menu) and you can choose the following parity item. Parity options are stored in nonvolatile memory.

#### Baud rate

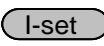
Press  (Shift)+  (Menu) , under the system menu, you can select a baud rate which is stored in nonvolatile memory:

4800/9600/19200/38400/57600/115200

#### RS-232 connection

RS-232 serial port can connect with controller serial port by using a piece of RS-232 cable with DB-9 interface.(such as PC). The following table shows the plug of the pin.

If your computer connect with RS-232 interface with DB-25 plug, you need a cable and a adapter which one aspect of the matter is DB-25 plug the other end is DB-9 plug.



Base pin number	Description
1	No conjunction
2	TXD, data transmission

RS232 Pins of Plug

3	RXD, data receiving
4	No conjunction
5	GND, grounding
6	No conjunction
7	CTS, clear to send
8	RTS, request to send
9	No conjunction

## RS-232 troubleshooting

If you are having trouble communicating over the RS-232 interface, check the following:

- The computer and the power supply must be configured for the same baud rate, parity, number of data bits, and flow control options. Note that the power supply is configured for 1 start bit and 1 stop bit (these values are fixed).
- The correct interface cables or adapters must be used, as described under RS-232 Connector. Note that even if the cable has the proper connectors for your system, the internal wiring may be incorrect.
- The interface cable must be connected to the correct serial port on your computer (COM1, COM2, etc.).

## Communication settings

Before communication, you should first make the following parameters of power supply and PC matches.

Baud Rate: 9600 (4800/9600/19200/38400/57600/115200). You can enter the system menu from the front panel, and then set the baud rate.

Data bits: 8

Stop bit: 1

Parity: (none, even, odd)

**EVEN**      Eight data bits have even check

**ODD**        Eight data bits have odd check

**NONE**      Eight data bits have no check

The machine address: (0 ~ 31, the factory a value of 0)

Parity=None	Start Bit	8 Data Bits	Stop Bit
-------------	-----------	-------------	----------

## 5.2 USB interface

You can connect the power and computer by using a USB cable with an A type port and a B type port. All the power function can be programmed through the USB.

The power supply USB488 interface functions are described as follows:



- Interface is 488.2 USB488 interface.

- Interface receive the request of REN\_CONTROL, GO\_TO\_LOCAL, and LOCAL\_LOCKOUT.
- Interface receive command information about MsgID = TRIGGER USBTMC and pass on TRIGGER order to function layer.

The power USB488 device function are described as follows:

- Equipment can read all the forced SCPI command.
- Equipment is SR1 enabled.
- Equipment is RL1 enabled.
- Equipment is DT1 enabled.

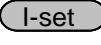
## 5.3 GPIB interface

First of all, you should make power supply GPIB port connecting to computer GPIB card through the IEEE488 bus. Make sure the connect is firmly and then set the address, power supply address range is: 0 ~ 31. You can Enter the system menu functions by pressing  (Shift)+  (Menu). You can find GPIB address settings through pressing  and Input address, then press  to confirm. GPIB address is stored in nonvolatile line storage.

## Appendix

### Specifications of Red and Black Test Lines

ITECH provides you with optional red and black test lines, which individual sales and you can select for test. For specifications of ITECH test lines and maximum current values, refer to the table below.

Model	Specification	Cross section	Length
IT-E301/10A	10A	-	1m
IT-E301/30A	30A	6mm <sup>2</sup>	1.2m
IT-E301/30A	30A	6mm <sup>2</sup>	2m
IT-E301/60A	60A	20mm <sup>2</sup>	1.5m
IT-E301/120A	120A	50mm <sup>2</sup>	2m
IT-E301/240A	240A	70mm <sup>2</sup>	1m
IT-E301/240A	240A	70mm <sup>2</sup>	2m
IT-E301/360A	360A	95mm <sup>2</sup>	2m

For maximum current of AWG copper wire, refer to table below.

AWG	10	12	14	16	18	20	22	24	26	28
The Maximum current value(A)	40	25	20	13	10	7	5	3.5	2.5	1.7

**Note: AWG (American Wire Gage), it means X wire (marked on the wire). The table above lists current capacity of single wire at working temperature of 30°C. For reference only.**





Call Us 1.877.571.7901

## Contact Us

Thanks for purchasing ITECH products. In case of any doubts, please contact us as follows:

1. Refer to accompanying data disk and relevant manual.
2. Visit ITECH website: [www.itechate.com](http://www.itechate.com)
3. Select the most convenient contact method, for further information.