

InFocus INV30(V30) projector

User's guide

InFocus

Table of contents

TABLE OF CONTENTS	2
SAFETY WARNINGS, CAUTIONS AND IMPORTANT INFORMATION	3
Precautions	3
Additional maintenance instructions	3
EU STANDARDS	3
INFOCUS INV30(V30) PROJECTOR PRODUCT FEATURES	3
PROJECTOR PACKAGE OVERVIEW	4
PRODUCT OVERVIEW	4
Main unit	4
Connections	5
Remote control.....	6
INSTALLATION	7
Turning on the projector	7
Putting the projector into Standby mode.....	7
Focusing the image	7
STATUS LIGHTS	8
PROJECTOR SETTINGS	8
Picture menu	8
Position menu	9
Setting menu	9
Audio menu	10
Options menu.....	10
LAN menu.....	11
APPENDIX	12
Pin configuration on the projector's RS-232 connector.....	12
RS232 Commands	12
Replacing the lamp	12
Clean Filters Note INV30(V30).....	15
COMPLIANCE	16
Waste Electrical and Electronic Equipment Regulations	16
Restriction of Certain Hazardous Substances (RoHS) Directives	16
CUSTOMER SUPPORT	16
Online support	16
Contacting InFocus Technical Support	16
General inquiries.....	16
WARRANTY	16
REGISTRATION	16
INV30(V30) SPECIFICATION	17



Safety warnings, cautions and important information

Follow all the warnings, precautions and maintenance instructions in this document and on the InFocus Support web site InFocus.com/Support

Precautions

- Do not look into the projector's lens when the lamp is on. The bright light may damage your eyes.
- To reduce the risk of fire or electric shock, do not expose this projector to rain or moisture.
- Do not open or disassemble the projector as this may cause electric shock.
- Before replacing the lamp, allow the projector to cool down and then turn it off. Disconnect the projector from the power outlet, and follow all the lamp replacement instructions.
- When you switch the projector off, ensure that the cooling cycle is complete before disconnecting the power. Allow 90 seconds for the projector to cool down.
- To extend lamp life, avoid turning the projector on and off frequently. Once you have turned on the projector, keep it on for a minimum of 15 minutes.
- When the lamp is approaching the end of its life, the message "Lamp is approaching the end of its useful life in full power operation" appears on the screen. Contact your local reseller or service center to change the lamp as soon as possible.

Additional maintenance instructions

- Turn off the product before cleaning it.
- Use a soft cloth moistened with a mild detergent to clean the display housing.
- Disconnect the power plug from the AC outlet if the product isn't being used for a long period of time.
- Do not block the ventilation slots and openings on the unit.
- Do not use abrasive cleaners, waxes or solvents to clean the unit.
- Do not use in extremely hot, cold or humid environments:
- Do not stare into the beam, RG2.
- "As with any bright source, do not stare into the direct beam, RG2 IEC 62471-5:2015"
- Do not look directly into the lens, eye damage could result.



EU standards

IEC 60950-1:2005 (Second Edition); Am1:2009 + Am2:2013. IEC62471-5:2015.



InFocus INV30(V30) projector product features

This product is a single-chip DLP® projector. Features include the following:

- DLP technology
- XGA 1024 x 768 resolution
- 4:3 with support for 16:9, 16:10 and 5:4 with scaling
- Short throw 0.63:1 ratio
- 99 cm (39") minimum throw distance
- 3000 lumens in 240 W mode at a CCT of 6500 K by the IEC method
- Computer compatibility
 - Mac OS X
 - Windows®
- Video interface compatibility
 - HDCP compliant HDMI, Composite, VESA® RGB with additional interface support for Component YPbPr and Component YCbCr inputs with the proper adapters (not included)
- Video system compatibility
 - HDTV (720p and 1080p) video system compatibility and HD Ready (HDMI technology and 720p) available, NTSC, NTSC 4:43, PAL, PAL-N, PAL-M and SECAM (480i/p and 576i/p)
- Remote manager via network and RS-232
- 17,000:1 contrast ratio

Projector package overview

This projector comes with all the items shown below. Check to make sure your package is complete. Contact your dealer immediately if anything is missing.

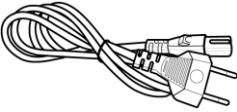
 <p>Projector</p>	 <p>Remote control</p>	 <p>Documentation</p>
 <p>Power Cord</p>		

Product overview

Main unit

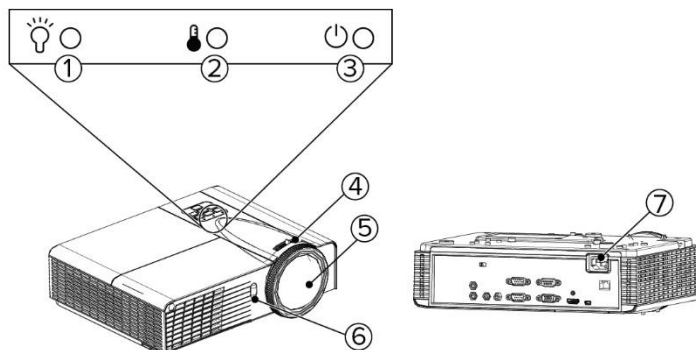

No.	Part	No.	Part
1	Lamp indicator light	5	Lens
2	Diagnostic indicator light	6	Infrared receiver
3	Power indicator light	7	Power port
4	Focus		

Connections

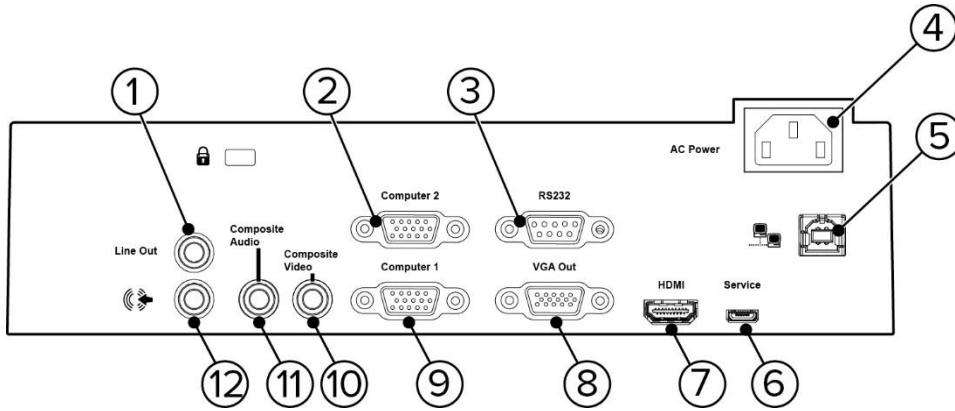

No.	Connector	No.	Connector
1	3.5 mm phone jack audio variable output	7	HDMI in
2	DB15F RGB VGA video input (VGA In)	8	DB15F RGB VGA video output (VGA Out)
3	DB9F RS-232 control port	9	DB15F RGB VGA video input (VGA In)
4	Power	10	RCA analog composite video (yellow)
5	RJ45 (Cat 5)	11	3.5 mm phone jack audio input (composite video)
6	USB Mini-B (for service access only)	12	3.5 mm phone jack audio input (shared by Computer 1 and Computer 2 input)

Remote control

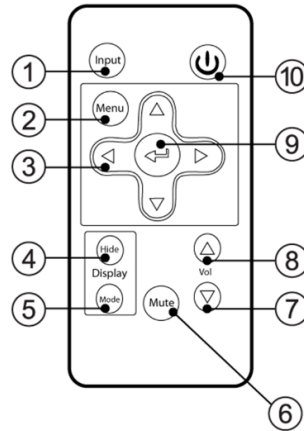

No.	Function	Description
1	Input	Select a video and audio input source on the projector and the associated USB input source on the extended control panel.
2	Menu	Show or hide the projector menus.
3	◀ (Left), ▶ (Right), ▲ (Up) and ▼ (Down)	Change the menu selections and adjustments.
4	Hide	Hide or display the image.
5	Mode	Select a display mode.
6	Mute	Mute audio.
7	▼ (Volume Down)	Decrease audio volume.
8	▲ (Volume Up)	Increase audio volume.
9	↵ (Enter)	Accept the selected mode or option.
10	⏻ (Power)	Turn on the projector or put it into Standby mode.

Installing the remote control battery

Follow this procedure to install the remote control battery.

1. Hold down the side release, pull out the battery holder.

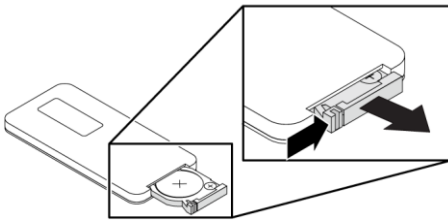

2. Insert the new battery in the battery holder.

Be sure to align the positive and negative terminals of the battery properly.

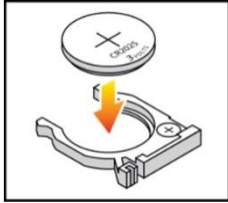

3. Insert the battery holder in the remote control.

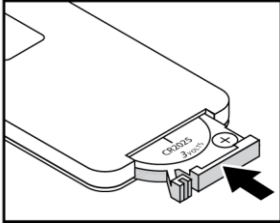

Installation

Turning on the projector

NOTE:

The first time you use the projector, you can select your preferred language from the main menu after the startup screen appears.

If you connect multiple sources at the same time, press **Input** on the remote control to switch between inputs.



1. Ensure that the power cable and the video signal cable are connected. The Power LED is solid red.
2. Turn on the lamp by pressing Power  on the remote control. The power light turns green, and the startup screen appears in approximately 10 seconds.
3. Turn on your source. Select **Input** on the remote control to select an input source (VGA-1, Composite or HDMI). The projector detects the source you select and shows the image.

Putting the projector into Standby mode

CAUTION:

Do not turn on the projector immediately after you put it into Standby mode.

Follow this procedure to put the projector into Standby mode.

1. Press Power  on the remote control to turn off the projector lamp.
2. Press Power  again to confirm your selection. If you don't press Power  again, the message disappears after 10 seconds.

Focusing the image

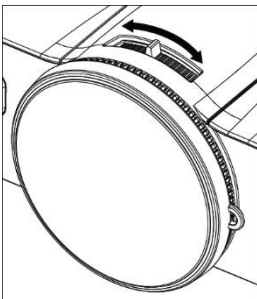

Use the focus lever to focus the projected image

Turn the focus lever clockwise or counterclockwise until the image is in focus.



Status lights

Use the following table to determine the status of your projector

 Power indicator light	 Temperature indicator light	 Lamp indicator light	Projector Status
Solid red	Off	Off	Standby
Flashing green	Off	Off	Powering up
Solid green	Off	Off	On
Flashing red	Off	Off	Cooling
Alternating green and red	Solid red	Solid red	Downloading firmware
Solid red	Solid red	Off	Projector over-heated
Solid red	Flashing red	Off	Fan failure
Solid red	Off	Solid red	Lamp failure
Solid red	Off	Flashing red	Color wheel failure

Projector settings

The remote control's Menu button enables you to access the on-screen display to adjust the projector settings.

Picture menu

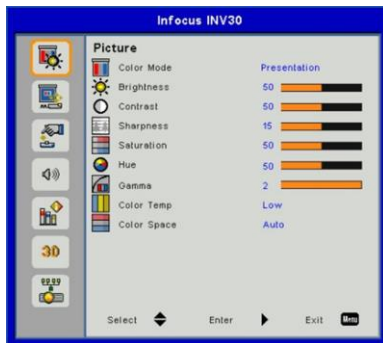

Setting	Description	Setting	Description
Color Mode	Indicates the projector's display output (Bright Classroom , Dark Classroom , Presentation , Game and User).	Hue	Sets the image hue from 0 to 100.
Brightness	Sets the projector's brightness from 0 to 100.	Gamma	Sets the gamma from 0 to 3.
Contrast	Sets the difference between the lightest and darkest parts of the image from 0 to 100.	Color Temp	Sets the color temperature (Low , Mid and High).
Sharpness	Sets the image sharpness from 0 to 31.	Color Space	Sets the signal color space (Auto , RGB and YUV).
Saturation	Sets the image saturation from 0 to 100.		

Position menu

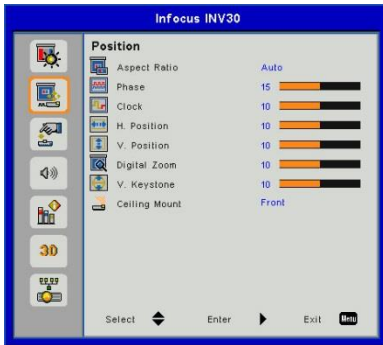

Setting	Description	Setting	Description
Aspect Ratio	Sets the image output to Auto, 4:3, 16:9 and 16:10.	V. Position	Determined by VGA source input only.
Phase	Determined by VGA source input only.	Digital Zoom	Sets the image zoom from 0 to 10.
Clock	Determined by VGA source input only.	V. Keystone	Sets the keystone correction of the image from -40 to 40
H. Position	Determined by VGA source input only.	Ceiling Mount	Sets the projector orientation Default is Front Ceiling .

Setting menu



Setting	Description	Setting	Description
Language	Selects the language preference from English, Spanish, Portuguese, French, Arabic, Chinese (Simplified), Chinese (Traditional), Czech, Dutch, German, Hungarian, Italian, Japanese, Korean, Norwegian, Polish, Romanian, Russian, Slovak, Swedish and Turkish.	Startup Logo	Turns on or off a startup logo when the projector lamp is starting and a video source signal isn't displayed.
Menu Location	Selects the menu position on the screen from Top Left, Top Right, Center, Bottom Left and Bottom Right.	UART Mode	Selects LAN terminal or the RS 232 terminal for UART mode.
Closed Caption	Turns on or off the closed captioning feature.	LAN (Standby)	Turns on or off the LAN terminal during standby
VGA Out (Standby)	Turns on or off the VGA out port during standby.	Reset	Resets projector settings to their default values.
Test Pattern	Turns on or off a projected circle pattern.		

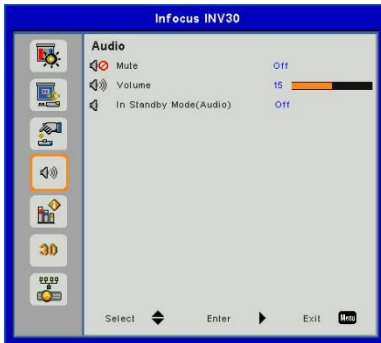

Audio menu

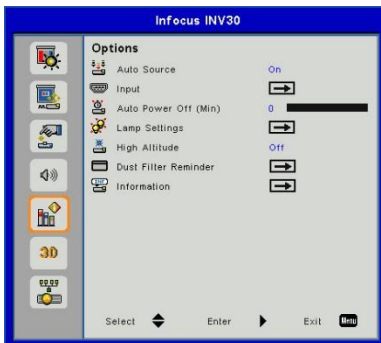

Setting	Description
Mute	Mutes the projector's audio output.
Volume	Adjusts the projector's volume from 0 to 32.
In Standby Mode	Turns on or off audio output when the projector is in Standby mode.

Options menu

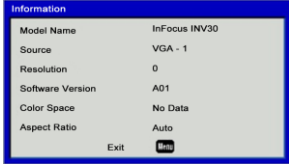

Setting	Description	Setting	Description
Auto Source	Turns on or off automatically switching to a video source.	High Altitude	Turns on or off high fan speed.
Input	Selects the video source (HDMI 1, VGA 1, VGA 2 or Video 1). 	Dust Filter Reminder	Adjusts the dust filter reminder settings. 
Auto Power Off	Sets the length of the auto power-off countdown timer between 0 to 120 minutes in 5 minute increments.	Information	Displays projector information. 

Lamp Settings	Displays current lamp hours, turns on or off the Lamp Life Reminder, sets lamp power mode and resets lamp hours		
---------------	-----------------------------------------------------------------------------------------------------------------	--	--

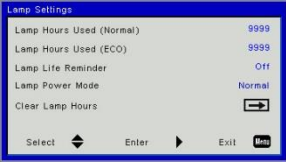

LAN menu

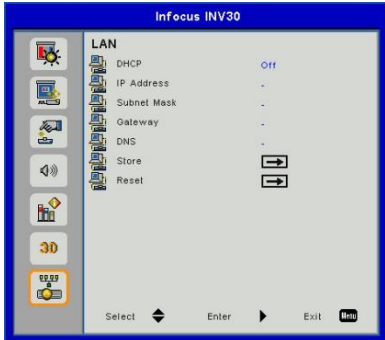

Setting	Description	Setting	Description
DHCP	Turns on or off the network's Dynamic Host Configuration Protocol (DHCP)	DNS	Shows the current DNS, can be changed with DHCP set to Off
IP Address	Shows the current IP address, can be changed with DHCP set to Off	Store	Stores the values you entered.
Subnet Mask	Shows the current Subnet mask, can be changed with DHCP set to Off	Reset	Resets values in the LAN menu to their default values.
Gateway	Shows the current Gateway, can be changed with DHCP set to Off		

Appendix

Pin configuration on the projector's RS-232 connector

The following table provides the pin configuration on the InFocus INV30(V30) projector. This pin configuration follows a three-wire connection so that a straight-through male-to-female RS-232 serial cable connects to the projector's serial interface in the following arrangement:

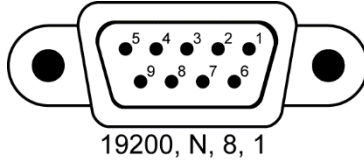

Pin number	Projector's female RS-232 connector
2	Transmit data (Tx)
3	Receive data (Rx)
5	Signal Ground (GND)

RS232 Commands

Command	Response	Target or Value
on	powerstate=powering	
off	powerstate=cooling	
set input=<target>	input=<target>	HDM1/VGA1/VGA2/Composite1
get powerstate	powerstate=<value>	powering; cooling; on; standby
get input	input=<value>	HDM1/VGA1/VGA2/Composite1
set vol+<value>		0-32
set vol-<val>		0-32
set vol=<val>		0-32

*Baud rate is 19200

Commands ignored during powering and cooling states

Replacing the lamp

Eventually the lamp module will dim, and a message will appear reminding you to replace the lamp. Make sure you have a replacement projector lamp module before proceeding.

Warning

- Replace the lamp when the projector displays its lamp life warning message **Lamp is approaching the end of its useful life in full power operation**. If you continue to use the projector after this message appears, the lamp can shatter or burst, scattering glass throughout the projector.



- If the lamp shatters or bursts, leave and then ventilate the area. Next do the following:
 - Avoid touching the glass fragments because they can cause injury.
 - Wash your hands thoroughly if you have come into contact with lamp debris.
 - Thoroughly clean the area around the projector, and discard any edible items placed in that area because they could be contaminated.
 - Call your authorized InFocus reseller for instructions. Do not attempt to replace the lamp.
- Before you remove the lamp, put the projector into Standby mode and wait 30 minutes for the lamp to cool completely. Disconnect the projector's power cord.
- Do not remove any screws other than those specified in the lamp replacement instructions.
- Wear protective eyewear while changing the lamp. Failure to do so can cause injuries including loss of eyesight if the lamp shatters or bursts.
- Use only replacement lamps approved by InFocus Technologies. Contact your authorized InFocus reseller for replacement parts.
- Never replace the lamp module with a previously used lamp module.
- Always handle the fragile lamp module with care to prevent premature lamp failure or exposure to mercury. Use gloves when touching the lamp. Do not touch the lamp with your fingers.
- Recycle or dispose of the lamp module as hazardous waste in accordance with local regulations. www.lamprecycle.org
See InFocusTech.com/compliance for the projector's Material Safety Data Sheet (MSDS) documents.

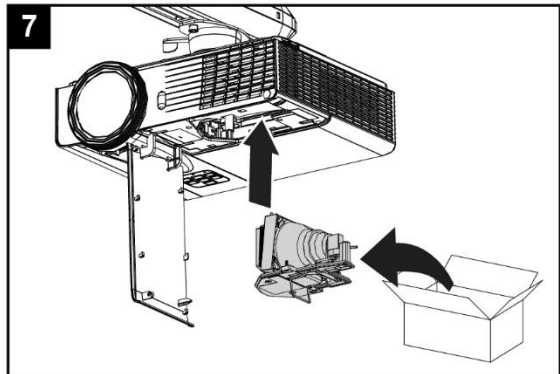
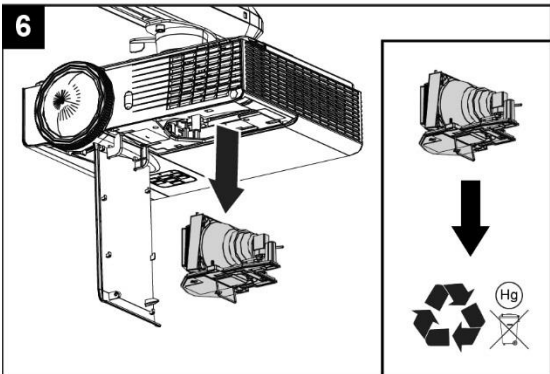
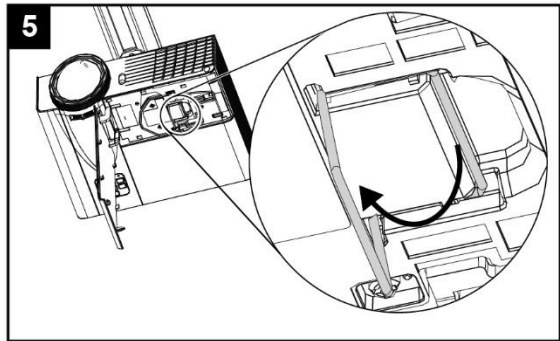
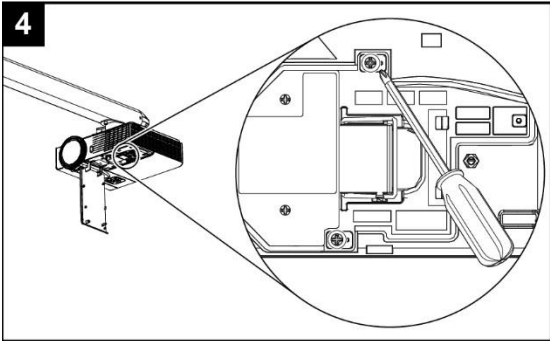
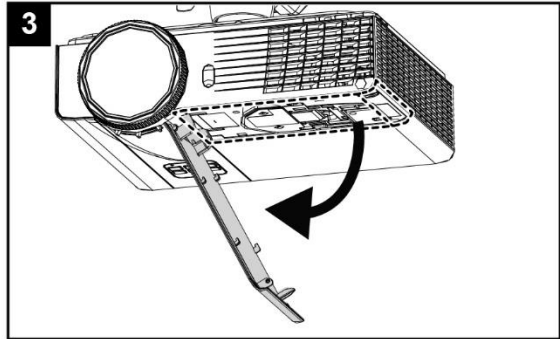
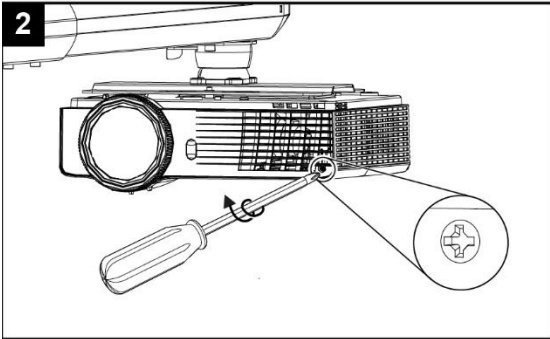
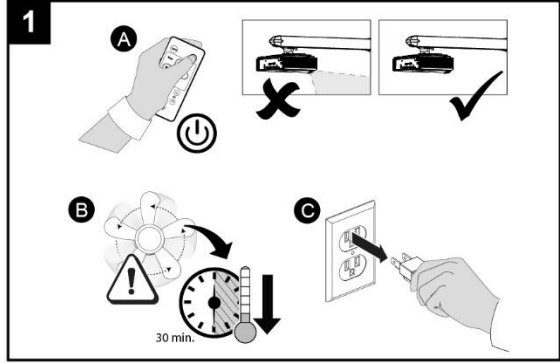
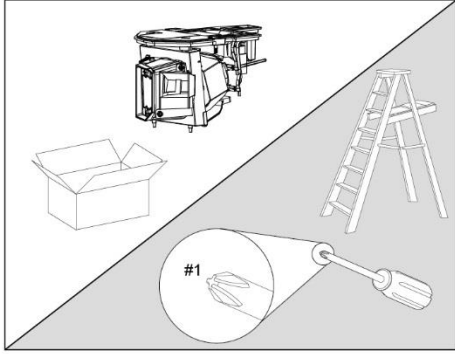

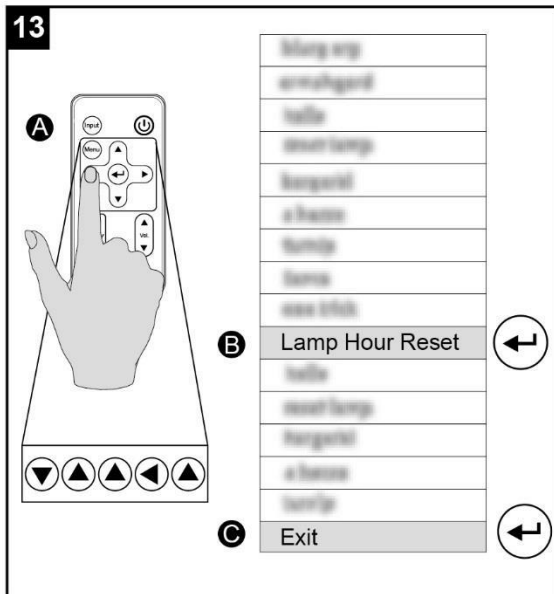
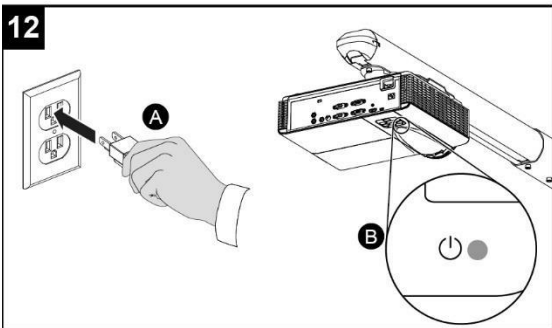
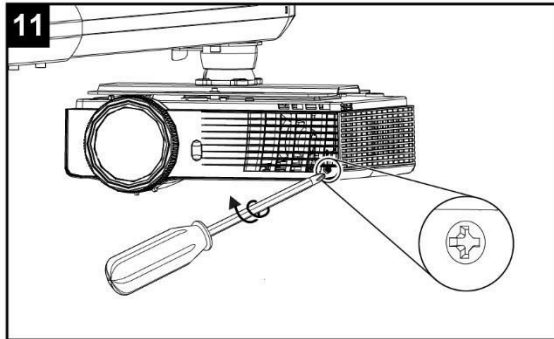
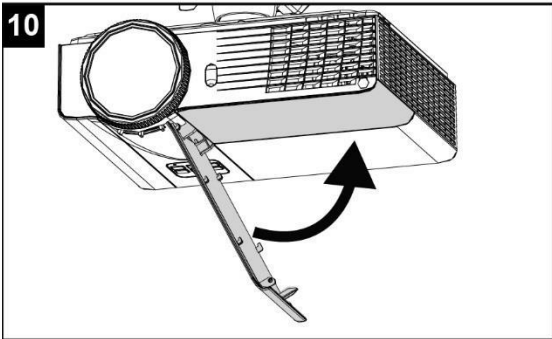
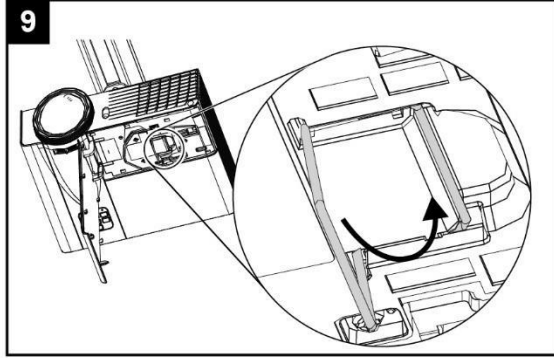
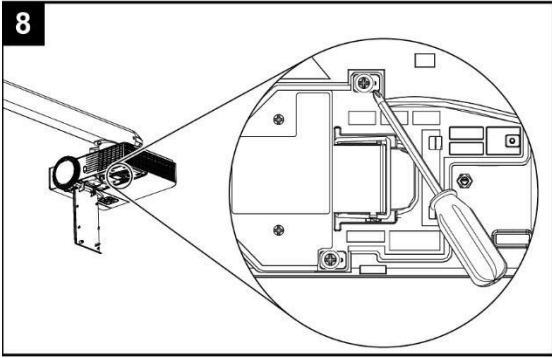

Filter Cleaning Instructions: SP.74013GC01

Regulatory

[Clean Filters Note INV30\(V30\)](#)

Warning:

Cleaning a wall-mounted projector can result in a fall or injury. Use caution when climbing a ladder.

Caution:

- Before you clean the projector press the **Power**  button twice on the remote control or projector keypad to put the projector in Standby mode, then wait 90 seconds for the fan to turn off.
- Never touch the lens with your hands or a brush.
- Do not allow liquids or commercial solvents of any kind to flow into the projector base or head.

Do not spray cleaners or solvents near any part of the projector because they can spread a chemical mist on some of the projector's components and lamp, resulting in damage, staining or poor image quality.

- Do not use compressed air to clean the projector.

A message will appear reminding you to clean the filters.

When cleaning the air filters:

Use compressed air to clean the filters.

You can also order replacement air filters (part no. SP.74013GC01) from your authorized InFocus reseller. It contains two replacement air filters.

To clean the air filters

1. Locate the two filters on each side on the rear of the projector.

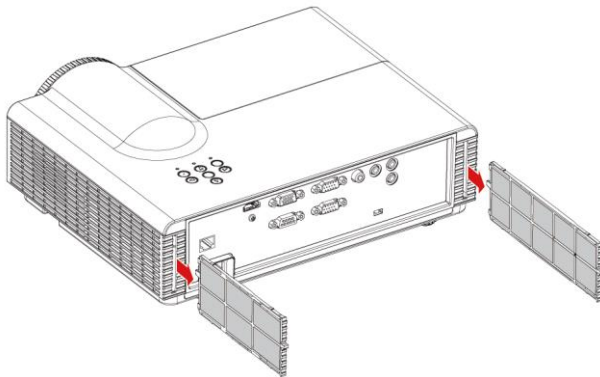

2. Remove the filters from the projector.
3. Clean the filter with compressed air. Insert the clean filter.

InFocus

Compliance

Waste Electrical and Electronic Equipment Regulations

Waste Electrical and Electronic Equipment regulations apply to all electrical and electronic equipment sold within the European Union.

When you dispose of any electrical or electronic equipment, including InFocus products, we strongly encourage you to contact your local WEEE recycling agency for recycling and disposal advice.

Your InFocus product required the extraction and use of natural resources for its production. It may contain hazardous substances. By disposing of electrical and electronic equipment appropriately, you lower the impact of these substances upon health and the environment and reduce the pressure on natural resources. Recycling agencies can reuse or recycle most of the materials from your product.

Please think about how you intend to dispose of any product that has a WEEE symbol or accompanying WEEE guidelines.



If you need more information on the collection, reuse and recycling of electrical and electronic equipment, please contact your local WEEE recycling agency. Alternatively, contact your local reseller or InFocus Technologies for information on the environmental performance of our products.

Restriction of Certain Hazardous Substances (RoHS) Directives

InFocus Technologies supports global efforts to ensure that electronic equipment is manufactured, sold and disposed of in a safe and environmentally friendly manner.

This product meets the requirements of the European Union's Restriction of Certain Hazardous Substances (RoHS) Directive 2011/65/EU.

Subsequently, this product also complies with other, less stringent directives that have arisen in various geographical areas, and that incorporate the European Union's RoHS directive as a basis.

For more information, refer to your local regulations or visit Infocus.com/Support.

Customer support

Online support

See infocus.com/support to view and download user documentation and software.

Contacting InFocus Technical Support

InFocus Technical Support welcomes your call. However, if you experience difficulty with your InFocus product, you may want to contact your authorized InFocus reseller first. Your InFocus reseller may be able to resolve the issue without delay.

Online: infocus.com/support

General inquiries

InFocus Technologies

13190 SW 68th Parkway, #200, Portland OR 97223 USA

1 503 207-4700

Warranty

Product warranty is governed by the terms and conditions of InFocus's Limited Equipment Warranty that shipped with the InFocus product at the time of purchase.

Registration

To help us serve you, register at InFocus.com/Register.

INV30(V30) Specification

Brightness (Standard)	3000 lumens in 240 W mode at a CCT of 6500 K by the IEC method
Brightness (Eco 1)	2250 lumens in 190 W mode at a CCT of 6500 K by the IEC method
Native resolution	XGA 1024 x 768
Aspect ratio	4:3 with support for 16:9, 16:10 and 5:4 with scaling
Throw ratio	Short-throw 0.630:1 ratio
Throw distance	39" (1 m)
Keystone	Vertical keystone adjustment available
Display technology	The projector uses DLP® technology by Texas Instruments™, providing BrilliantColor™ performance and quality Gamma 2.2 correction with Bright Room, Dark Room, sRGB, User and Presentation modes
Color support	24 bit (16.7 million colors)
Lamp life	6500 hours in Standard (ImageCare) 240 W mode. 8000 hours in Eco 1 (ImageCare) 190 W mode.
Integrated speaker	5 W RMS
Projector noise	38 dBA (Normal mode) or 32 dBA (Eco 1 [Image Care]) measured using the ISO-7779 method
Contrast ratio	(typical) 3000:1
Video system compatibility	HDTV (720p and 1080p) video system compatibility and HD Ready (HDMI technology and 720p) available, NTSC, NTSC 4:43, PAL, PAL-N, PAL-M and SECAM (480i/p and 576i/p)
Video interface compatibility	HDCP compliant HDMI, Composite, VESA® RGB with additional interface support for Component YPbPr and Component YCbCr inputs with the proper adapters (not included)
Horizontal frequency	15 kHz–72 kHz
Vertical frequency	25 Hz–75 Hz
Clock frequency	165 MHz
External management	Infrared remote control, RS-232 control port, internal web page
Theft protection	Padlock ring
Included cables and hardware	Infrared remote control 14' 9" (4.5 m) power cable
Weight (N.W)	5 lb. 12 oz. (2.6 kg)
Shipping dimensions (N.W)	16 1/4" W x 13" H x 5 3/4" D (41.8 cm x 33 cm x 14.7 cm)
Connectors	3.5 mm phone jack audio input (shared by VGA 1 and VGA 2 input) 3.5 mm phone jack audio input (composite video) 3.5 mm phone jack audio variable output DB15F RGB VGA video input (VGA In) x 2 DB15F RGB VGA video output (VGA Out) DB9F RS-232 control port HDMI 1.4 input 1.8M power cable (100V–240V AC at 50 Hz–60 Hz) Mini-USB B port (for service use only) RJ45 Ethernet connector RCA analog composite video (yellow)
Storage and operating requirements	
Power consumption	Normal mode 310 W Eco 1 mode 240 W Standby mode 0.5 W Standby mode with network enabled ≤ 4 W
Operating temperature	0' to 2500' (0 m to 762 m): 41°F to 104°F (5°C to 40°C) 2500' to 5000' (762 m to 1524 m): 41°F to 95°F (5°C to 35°C) 5000' to 10 000' (1524 m to 3048 m): 41°F to 86°F (5°C to 30°C)
Storage temperature	14°F to 140°F (-10°C to 60°C)
Humidity	Up to 80% storage relative humidity, non-condensing. Up to 80% operating relative humidity, non-condensing.
Certification and compliance	Regulatory certification CB, CE, FCC, UL, EAC



- Month and year of manufacturing of technical device, please refer to the SN label on I/O port (Year/Month: 201009).