

Technical Specifications

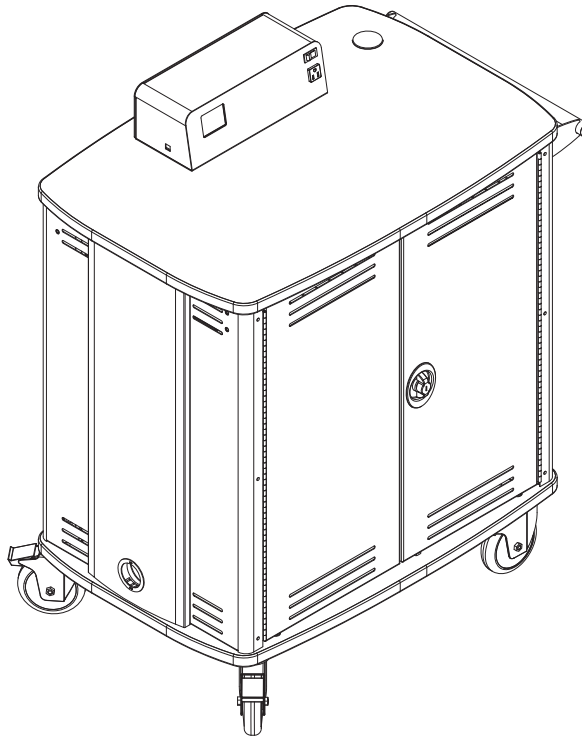

InTouch 40 Cart with Sync / Charge	
55438	with cord reel
55439	with cord wraps

InTouch 20 Cart with Sync / Charge	
55436	with cord reel
55437	with cord wraps



205 Westwood Ave, Long Branch, NJ 07740
Phone: 866-94 BOARDS (26273) / (732)-222-1511
Fax: (732)-222-7088 | E-mail: sales@touchboards.com

Spectrum's InTouch 40 Tablet Cart with Sync / Charge System is a unique cart designed to store, transport, recharge, and sync up to 40 iPad computers. Designed specifically for the iPad and other tablets that use a single USB cable for both syncing and charging functions, the easy-to-use Sync / Charge System provides the ability to charge or synchronize / image these devices. The cart stores up to 40 computing devices up to 1" thick in individual vertical compartments with soft plastic dividers. Simple wire management trays store and route USB cables directly above each tablet for easy student access. The teachers laptop and accessories easily store in an optional pull-out shelf directly above student tablets.

Features and Benefits

- Storage for up to 20, or 40 iPad computers (up to 1" thick) with easy-access to electrical power
- Intuitive Sync / Charge System synchronizes or charges iPads exclusively through USB connection
- Ample clearance is provided for easy removal/insertion of tablets
- Durable powder coated steel chassis
- Scratch and impact-resistant 1 $\frac{1}{8}$ " high-pressure laminate worksurface
- Two directional, swivel locking 5" balloon wheels can be rotated and locked at 180° intervals for steering purposes and make the unit extremely mobile for easy transport between classrooms.
- Pull-out trays keep cords and charge blocks organized
- Numbered storage slots keep tablet computers organized
- Students have access to tablet computers and USB only through locking student-side doors
- Doors and side panels are effectively ventilated for circulating "chimney effect" airflow to keep tablets cool
- Durable plastic dividers protect iPads from damage
- Storage area at top of cart provides 28 $\frac{3}{8}$ "W x 13 $\frac{1}{4}$ "D x 4 $\frac{1}{2}$ "H of space for a laptop or other items
- Cord management system keeps cords organized and routed to each storage slot
- 20-port USB power unit(s)
- Electrical system consists of UL-listed components
- External cord management brackets keep power cord organized
- Cable grommets strategically placed throughout for effective cord management
- One standard handle provides control and mobility
- Optional pull-out instructor tray provides 25 $\frac{3}{8}$ "W x 11 $\frac{3}{8}$ "D x 2 $\frac{1}{8}$ "H of storage for a laptop or other peripherals
- Optional 15' retractable UL-listed 15-amp power cord reel provides quick and easy power-access
- Optional pull-out instructor shelf provides additional storage for a laptop or other peripherals
- Warranted to be free of all defects in materials and workmanship with a 10-year warranty

Capacity
40 or 20 tablets

Base
DW - 5" balloon wheels (2 rigid, 2 swivel directional locking)

Options & Accessories
Page 14

Color Options

Standard laminate / color combinations

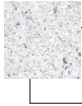
White Fiesta / Cool White (WFCW) 

Standard color combination refers to the quickest deliverable product color combination. Custom laminates and color combinations are available-additional lead-times and up-charges may apply. Call 1-800-235-1262 for further information.

Construction

- The worksurface and base panel is constructed from 1½" thick NAUF (no added urea formaldehyde) composite board with .030 high-pressure laminate on one face, and a balancing phenolic backer on the opposing face
- 16-gauge steel side panels, doors, and shelves
- Worksurface edges are covered with 3mm vinyl
- All metal components are finished with a scratch-resistant powder coat epoxy
- Each InTouch Tablet Cart is factory-assembled, packaged, and shipped on its own skid. handle, and cord wrap brackets, to be installed by customer.

Specifications

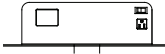
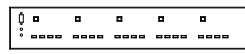
iPad capacity	qty 40 (InTouch 40)	qty-20 (InTouch 20)
Storage slots	1¼"W x 12½"D x 9⅞"H	
Available space in storage area at top of cart	28⅞"W x 13¼"D x 4½"H	
5" balloon wheels	weight capacity 325 lbs each	
Electrical	  <p>Sync / Charge unit with display:</p> <ul style="list-style-type: none"> • USB port for syncing device on worksurface • lighted on/off switch • 15' nominal AWG 3-wire power cord • 15-amp breaker • 2A auxiliary outlets (one above worksurface, one below worksurface) • touch screen display with intuitive menus and options (see p.13 for more info) <p>20-port USB power unit(s):</p> <p>InTouch 40 - qty 2 InTouch 20 - qty 1</p>	
Cord reel (55436, 55439 only)	15' retractable, 15-amp, 12AWG, with breaker, UL-listed	
Available space on optional pull-out instructor tray	25⅞"W x 11⅞"D x 2⅞"H	
Unit weights (nominal)	InTouch 40 216 lbs - 55438, 55439	InTouch 20 184 lbs - 55436, 55437
Shipping weights (nominal)	InTouch 40 258 lbs - 55438, 55439	InTouch 20 223 lbs - 55436, 55437
Meets or exceeds all ANSI-BIFMA test standards		

Specifications subject to change without notice

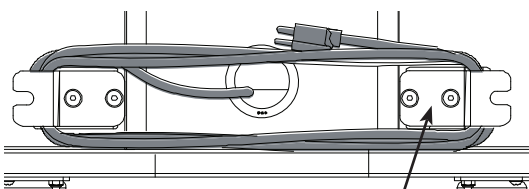

cord wrap brackets on lower side of cart

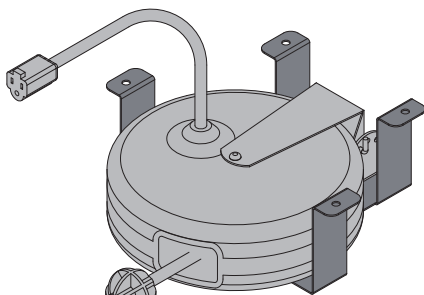

optional cord reel

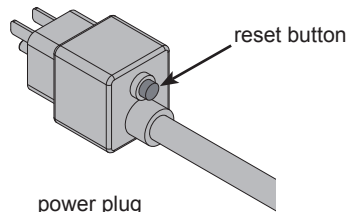

power plug

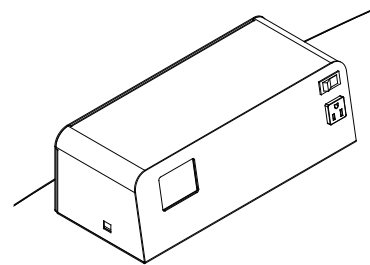

Sync / Charge unit

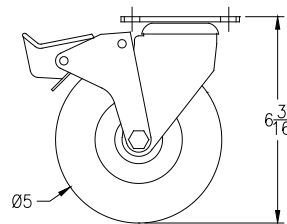

5" balloon wheel

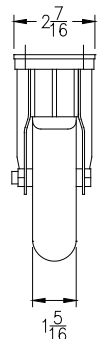

Note: Two swivel directional locking 5" balloon wheels can be rotated and locked at 180° intervals to be rigid, or unlocked to be swivel, and allow the unit to be extremely mobile for easy transport between classrooms.

InTouch Cart with Sync / Charge System
(shown w/ cord reel)

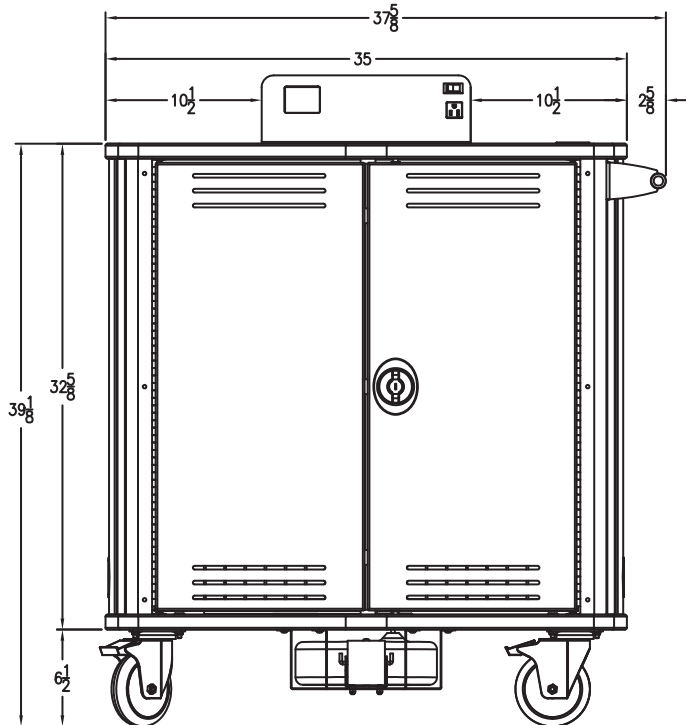
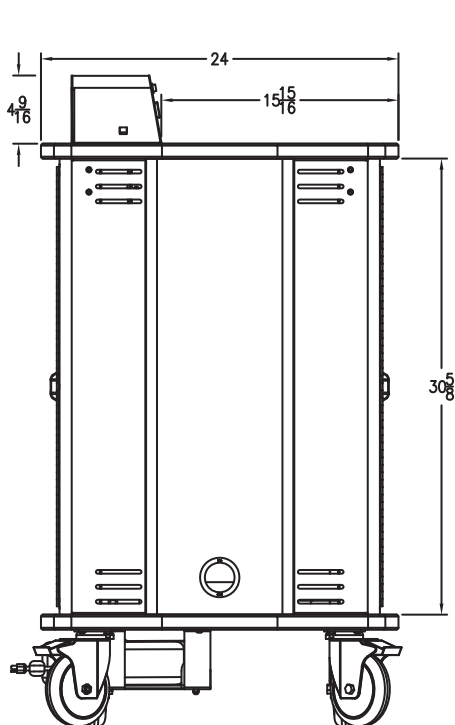
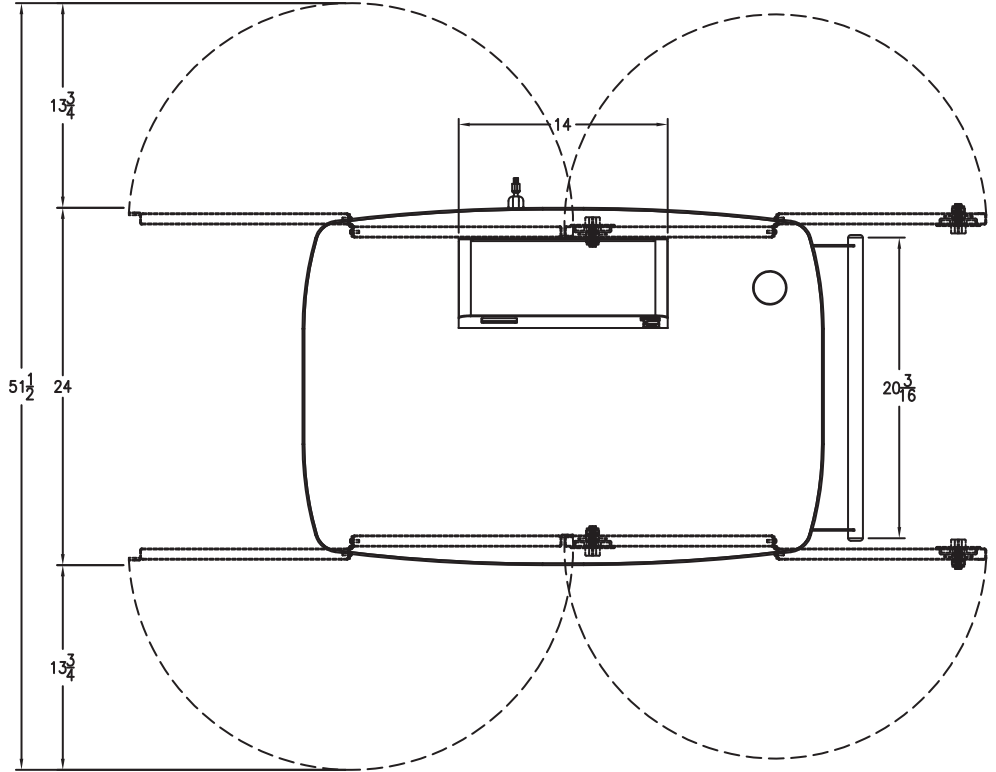
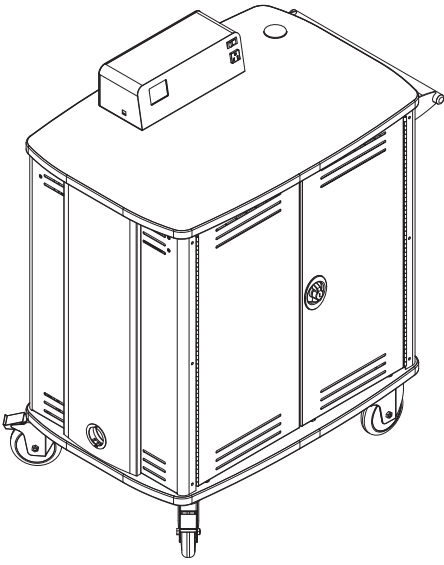

side view
(shown with doors removed)

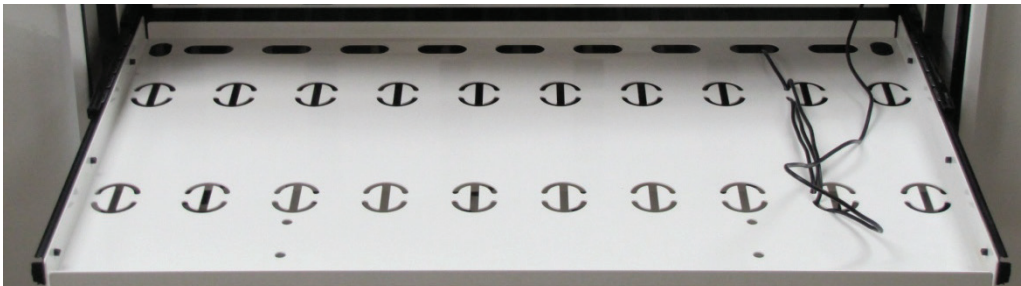
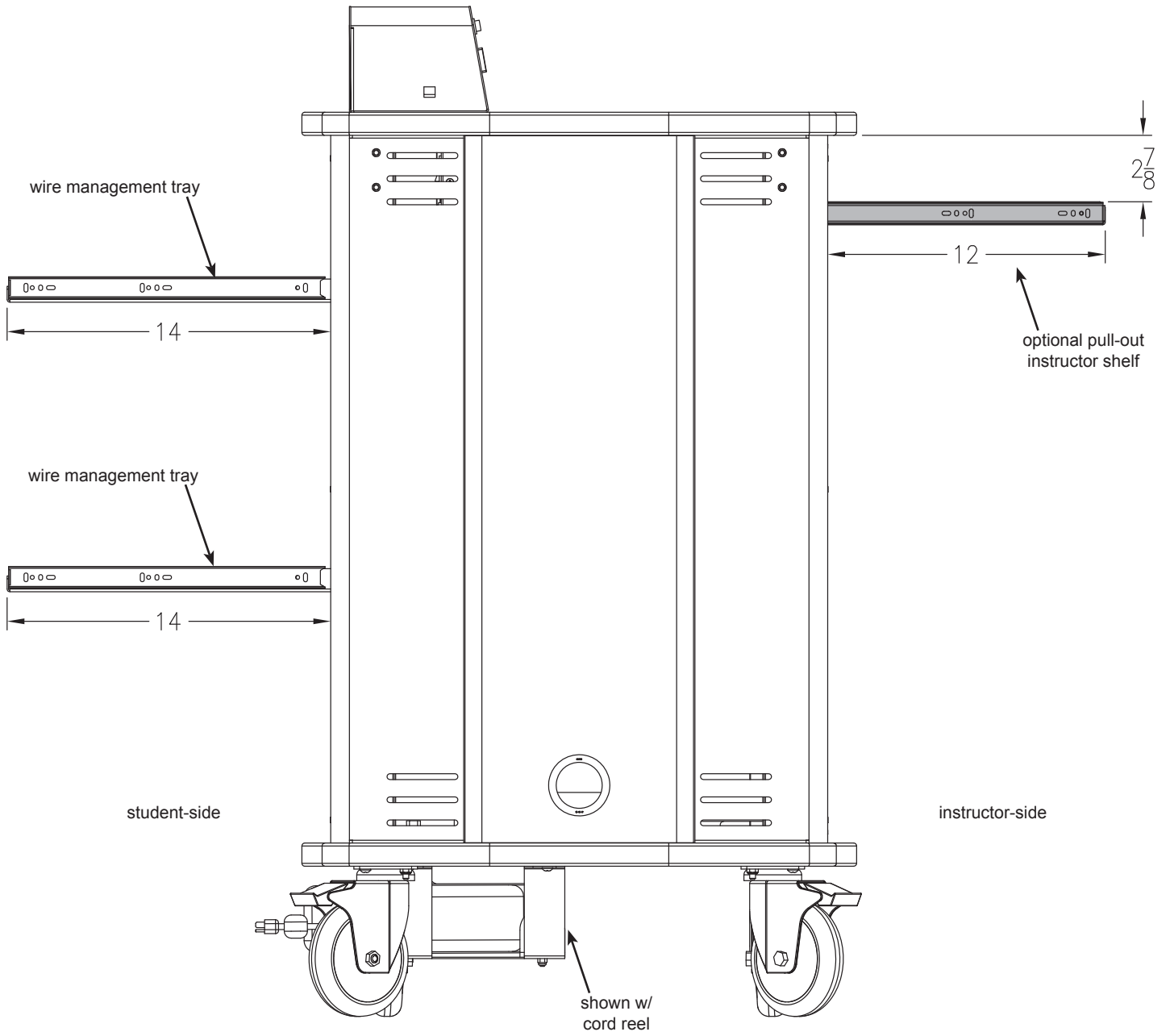

optional pull-out
instructor shelf

InTouch 40 Cart

student-side view
(shown with doors removed)

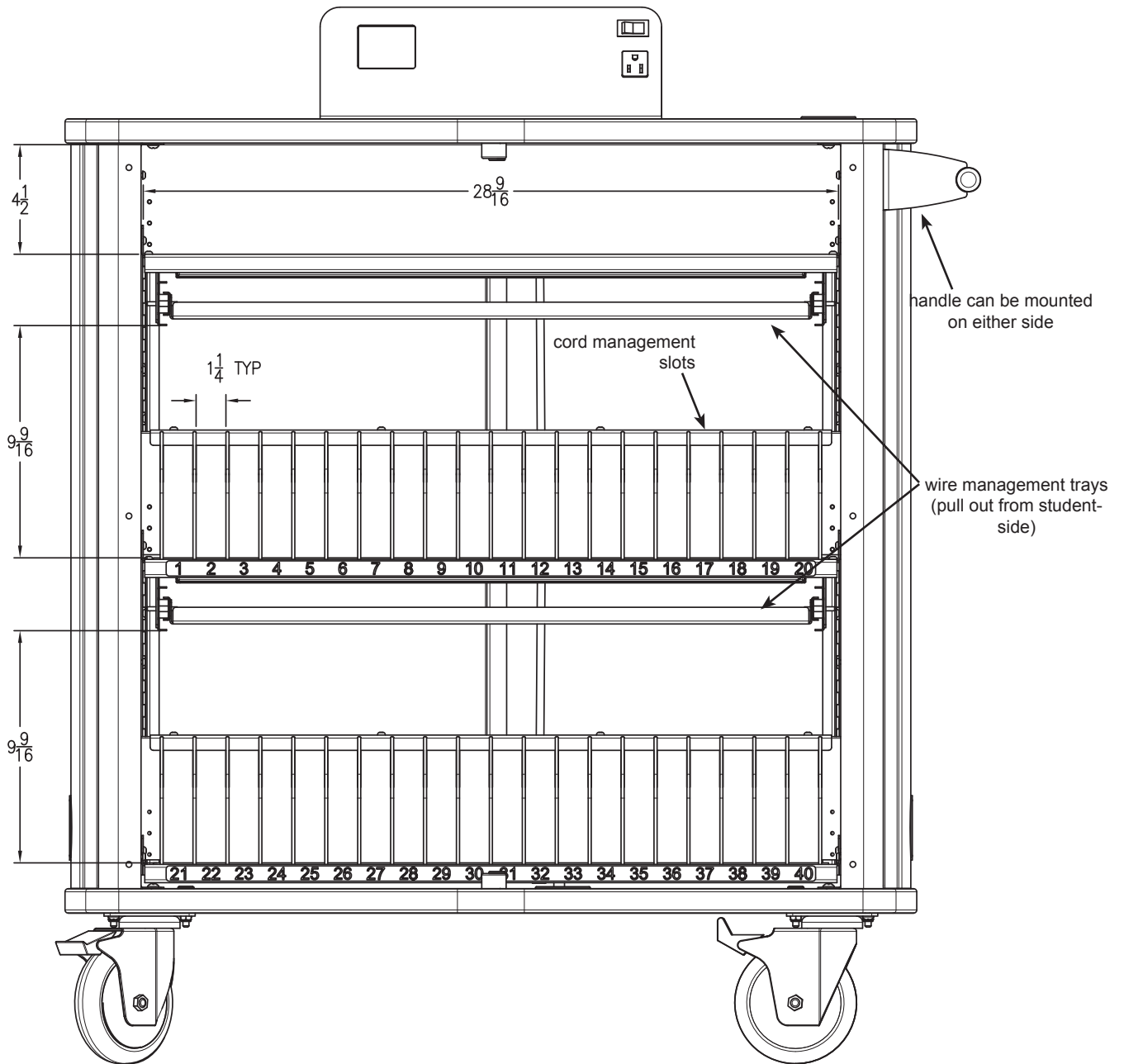

InTouch 40 Cart

instructor-side view
(shown with doors removed)

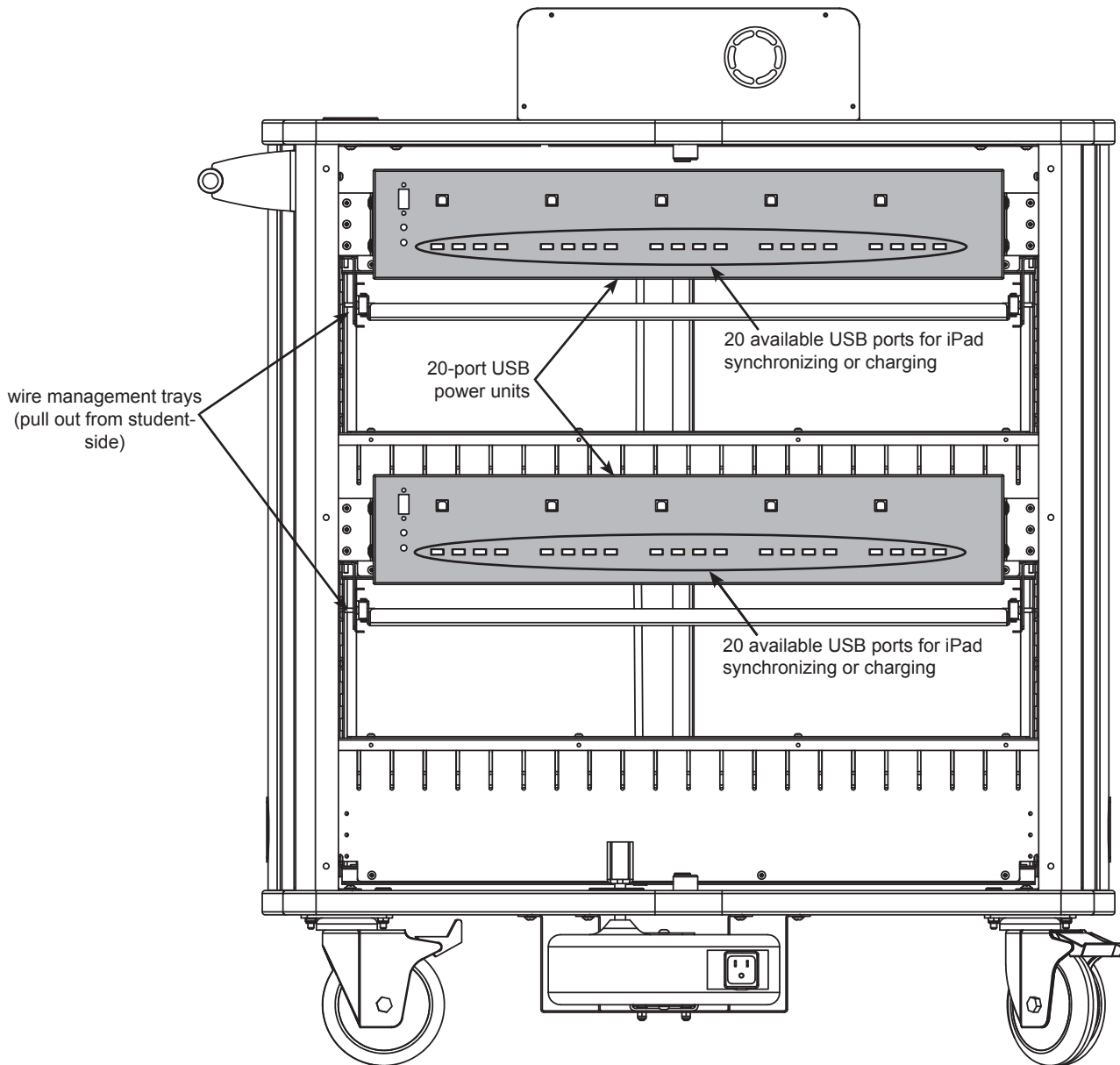

InTouch 40 Cart

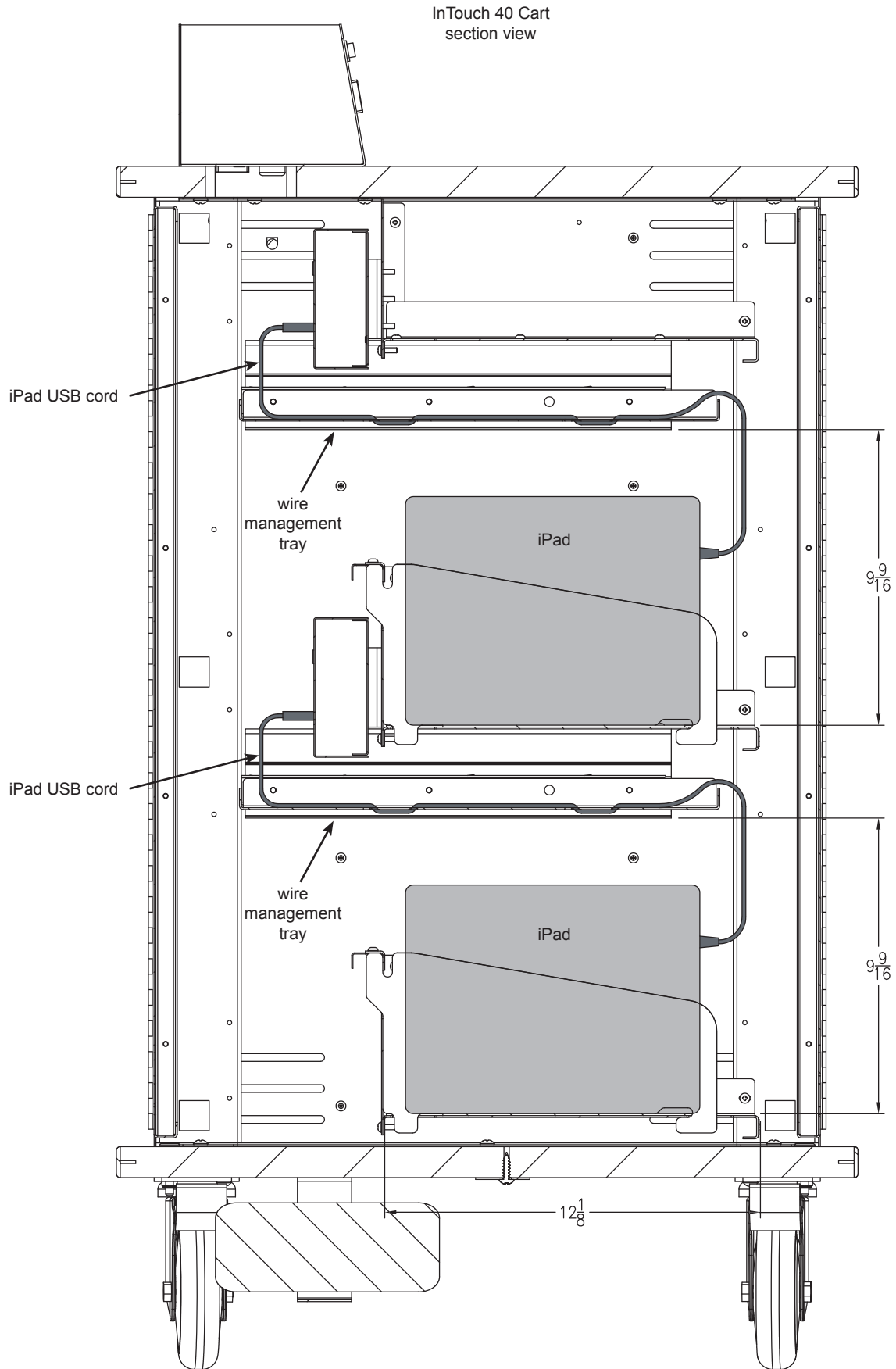

InTouch 40 Sync / Charge & USB Power Unit Wiring

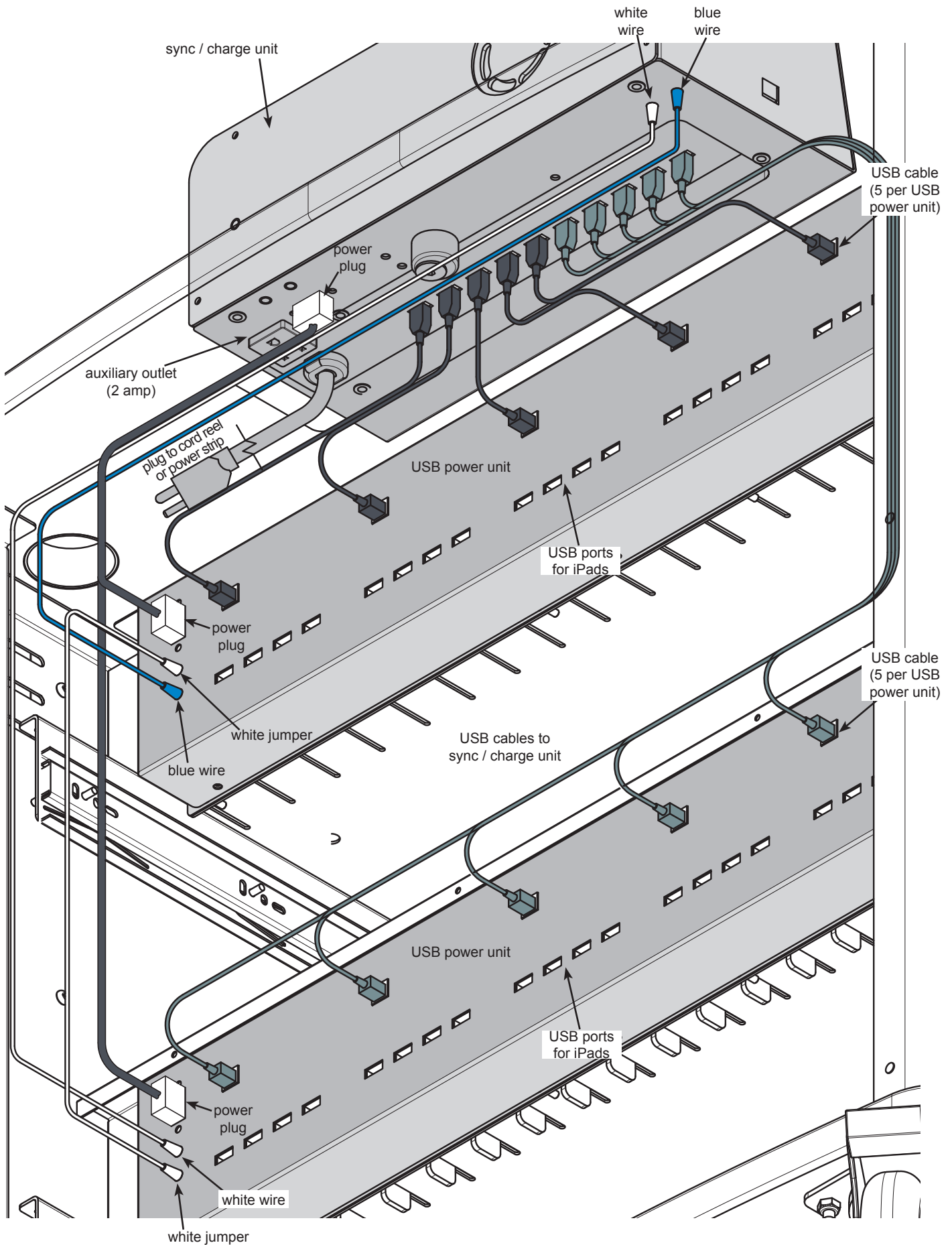

InTouch 20 Cart

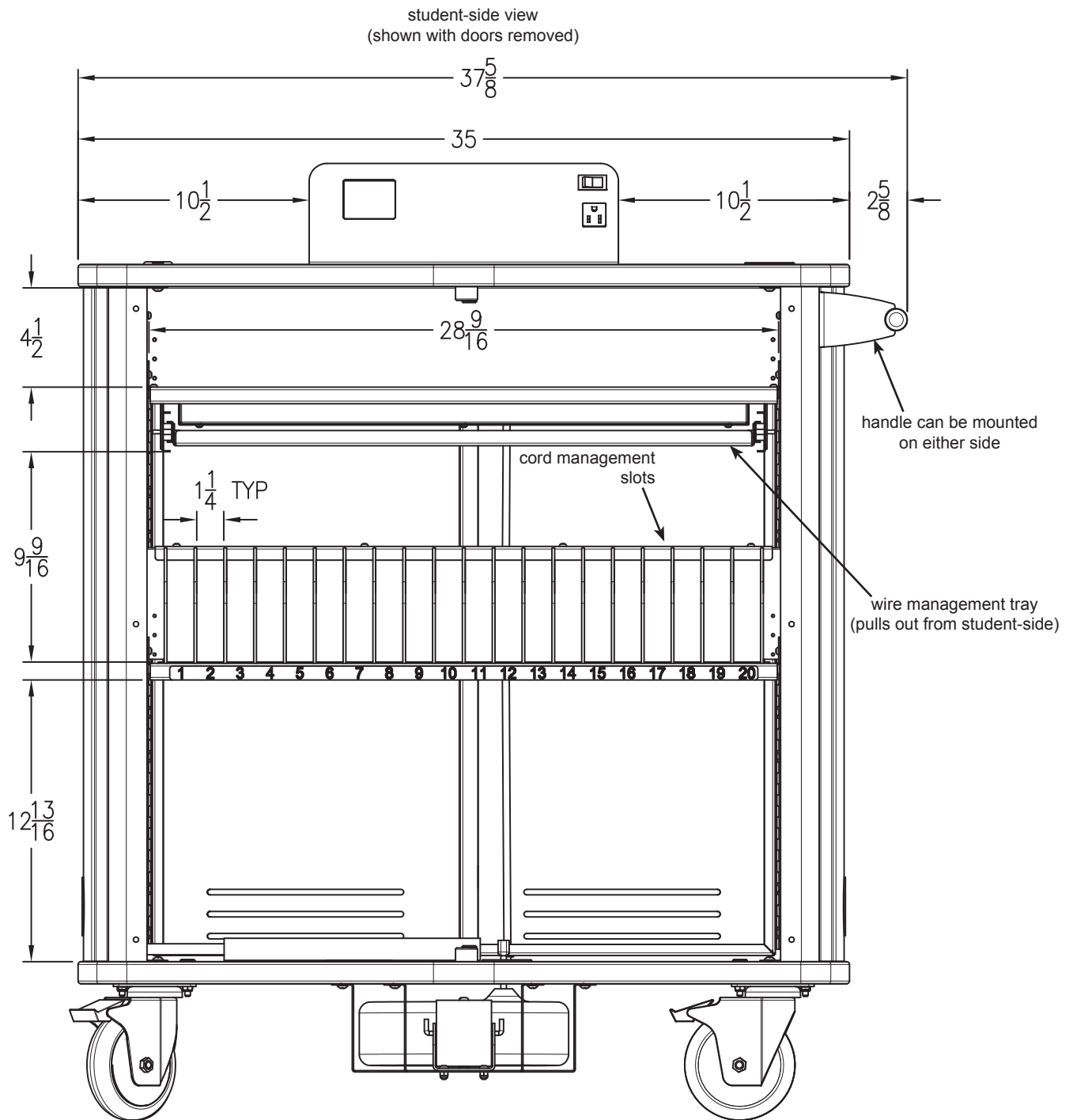

InTouch 20 Cart

instructor-side view
(shown with doors removed)

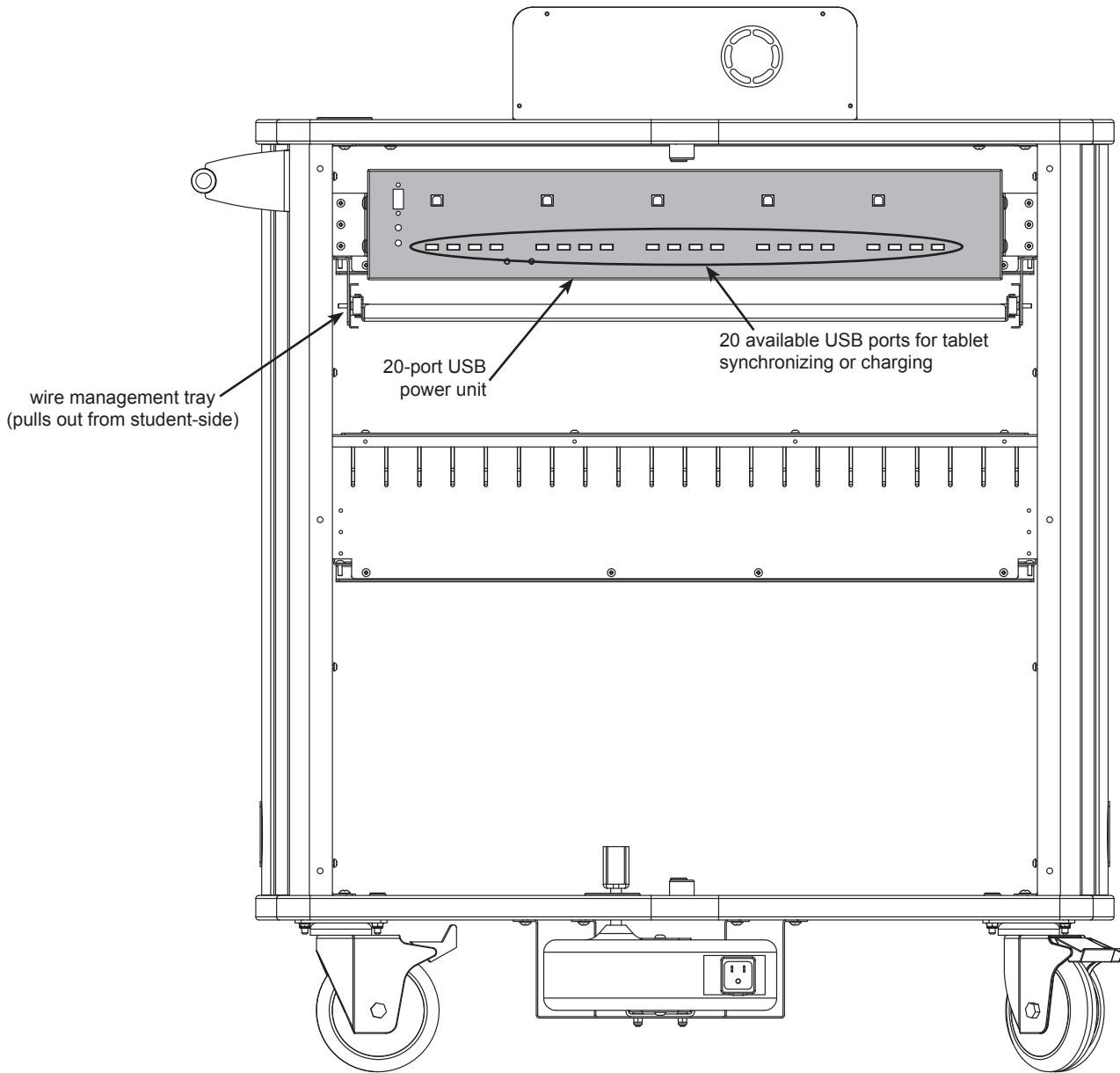

InTouch 20 Cart

InTouch 20 Cart
section view

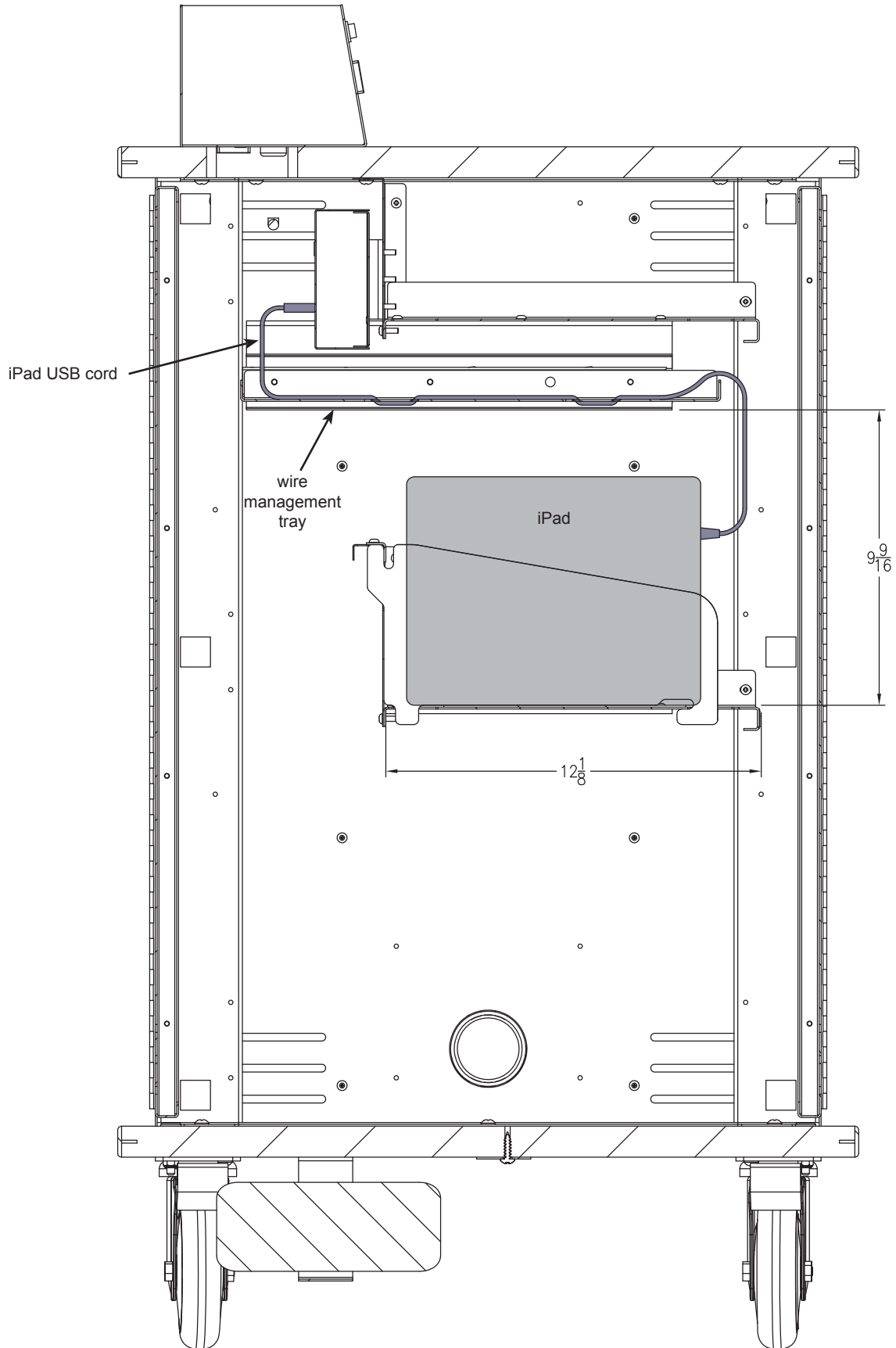

InTouch 20 Sync / Charge & USB Power Unit Wiring

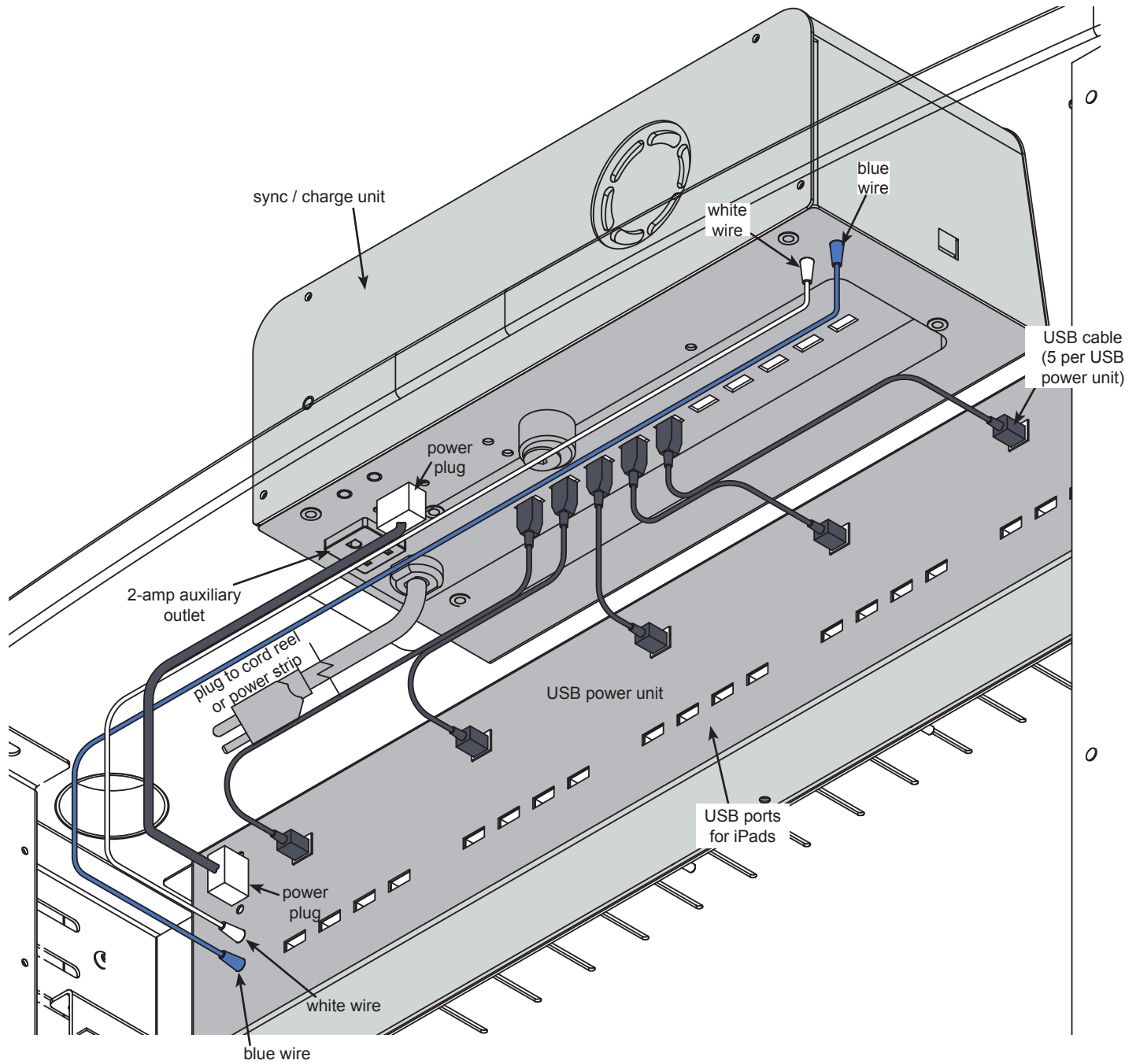

Sync / Charge™ Unit

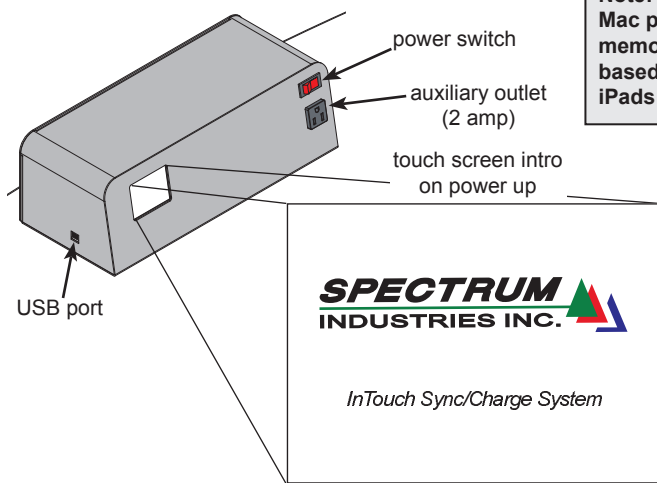

Note: For best syncing results, use an Apple Mac product as the host computer with enough memory to download to iPads. Windows-based products have limitations on quantity of iPads they can sync at one time.

Note: All cables should remain plugged in while power is present. If cables are removed and reconnected, the power must be reset to the host computer and cart.

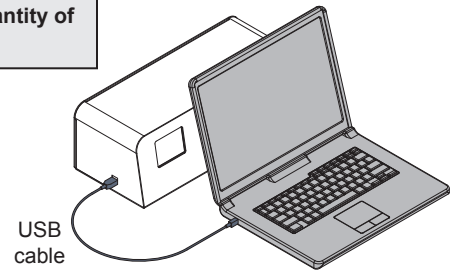

Plugging a host computer USB cable into the side USB port at any time while the unit is powered on will cause the system to switch to Sync Mode. Unplugging the USB cable will return system to Charge Mode.

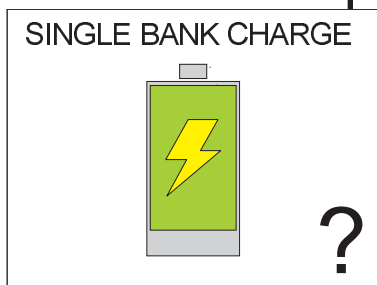

If only one bank is plugged in and detected (**InTouch 20 Cart**), the Single Bank Charge Mode is displayed until the host computer is plugged in.

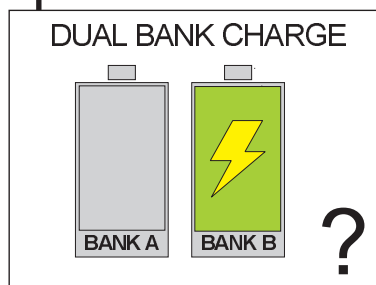

If two banks are plugged in and detected (**InTouch 40 Cart**), the Dual Bank Charge mode is displayed until the host computer is plugged in. Charging will cycle between banks at 15 minute intervals.

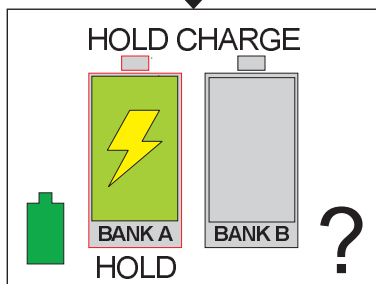

Press the 'A' or 'B' battery icon hold charge on either bank and discontinue cycling. Press the small battery (charge) icon to return to the Dual Bank Charge Mode.

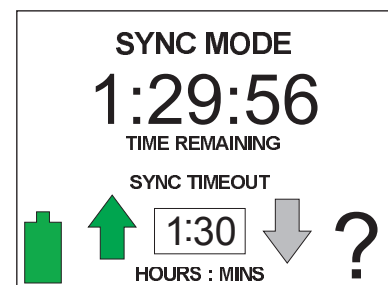

Sync Mode Timer

- Syncs up to 40 iPads at once
- Can be set from 30 min to 9.5 hrs by touching arrows (default setting: 30 min)
- Shows countdown in minutes
- Switches to Charge Mode after time expires or battery (charge) icon button is pressed

Note: Be sure to allow enough time on the automatic sync time-out for all downloading and syncing to be completed to iPad's.

CHARGE MODE HELP X

- Charges side A and B
- Push A to hold charge on side A
- Push B to hold charge on side B
- To enter SYNC MODE, plug in host computer
- Push small battery icon to return to Charge Mode.
- Further assistance call: 1-800-235-1262

To access the help screen, press ? in the lower right corner. When the help screen is displayed, the system remains on and continues operation in Charge Mode. Press X to return to the previous screen.

SYNC MODE HELP X

- SYNC TIMEOUT will switch to Charge Mode when time expires at indicated interval.
- Push small battery icon to return to Charge Mode Manually.
- Further assistance call: 1-800-235-1262

To access the help screen, press ? in the lower right corner. When the help screen is displayed, the system remains on and continues operation in Sync Mode. Press X to return to the previous screen.

Options

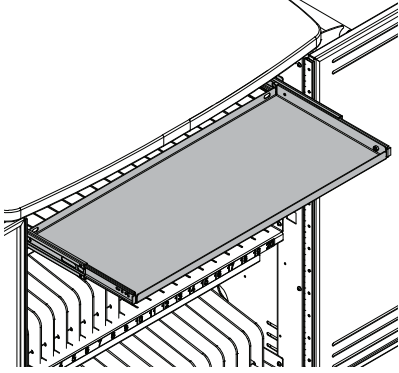

Pull-out Instructor Shelf
(for instructor laptop or storage)
25 $\frac{7}{16}$ "W x 11 $\frac{3}{8}$ "D x 3 $\frac{13}{16}$ "H
55442

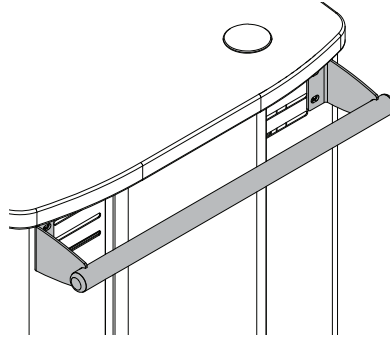

Additional Steel Handle
(mounts on left or right-max 2 per unit)
20 $\frac{3}{16}$ "W
55393



Replacement Key Set
55142

Warranty

WE WILL MAKE IT RIGHT FOR YOU!

Spectrum is committed to provide complete customer satisfaction. Each of our products are manufactured from the best materials available and each product is stringently monitored throughout the production process through our P.A.C.E. program (Product Assurance to meet Customer Expectations). Our Customer Service Help Line 1-800-235-1262 is ready to provide immediate attention to any questions, comments or concerns. We are available to answer your calls Monday through Friday from 7 am to 5 pm CST, excluding observed holidays. In addition your product comments or concerns are welcome via e-mail at: spectrum@spectrumfurniture.com.

Warranty Statement

We guarantee all Spectrum products to be free of all defects in materials and workmanship, for the original owner, for a period of ten years. Any item deemed defective by Spectrum or the original manufacturer, under normal use conditions, will be repaired or replaced at Spectrum's discretion. This warranty applies to all products manufactured and distributed by Spectrum except the products listed below.

Items that have a varying warranty include, but are not limited to, the following:

- Adjustable Crank/Electric Desk Legs (1 yr)
- Flat Panel Desk Gas Cylinders (1 yr)
- Upholstered Soft-Goods (5 yrs)
- Adjustable Height & Stacking Chair Parts – including frames, gas cylinders, wood and plastic parts, and control handles (7 yrs)
- Adjustable Height & Stacking Chair Casters (2 yrs)
- Chair Upholstery & Textiles (2 yrs of normal use of Soft Goods, Adjustable Height, Stacking, Wood and Metal Chairs)
- Chair Upholstery - Graded-In Fabrics and C.O.M (no warranty)
- Height Adjustable Columns and Lifts (1 yr)
- General Use Casters (1 yr)
- Electrical – Electri-Pak, Power Communication Modules, and special order ECA electrical items (1 yr)
- Electrical - Power Strips & Electrical Timers (1 yr)
- Electrical Surge Suppressors (lifetime)
- Electrical - Retractable Power Cords (1 yr)
- Keyboard/Mouse Trays (1 yr)
- Flat Panel Monitor Arm – General Parts (5 yrs)
- Flat Panel Monitor Arm – Gas Cylinders (2 yrs)
- CRT Monitor Arm (1 yr)

Warranty is void if product is not used for its intended purpose or subjected to an unusual application, multiple-shift use, alteration, accident, abuse or abnormal wear and tear. Representations of colors on-line and in printed materials are meant to be a close reference to the actual colors but not an exact match. Slight variations in color and texture of wood stains, powder coating, laminates, fabrics and other materials are normal in different manufacturing lots; as such these variations are not considered defects.

DESIGNED FOR INDOOR USE ONLY – Unless specifically stated in the product specifications, Spectrum's products have been designed and constructed for indoor use only. Moving or using outdoors, or on excessively rough surfaces, may cause damage to the products and will void the warranty. If an outdoor application is desired please contact us to discuss potential custom design solutions.

The warranty, as stated above, supersedes any previous warranties and is effective as of 9/1/2010



Touchboards

205 Westwood Ave, Long Branch, NJ 07740
Phone: 866-94 BOARDS (26273) / (732)-222-1511
Fax: (732)-222-7088 | E-mail: sales@touchboards.com



INDOOR AIR QUALITY
Indoor Advantage | Furniture

