

Owner's Manual

InTouch 40 Cart with Sync / Charge™ System for iPads®

InTouch 40 Cart with Sync / Charge™ System	
55438	with cord reel
55439	with cord wraps

Touchboards

205 Westwood Ave, Long Branch, NJ 07740
Phone: 866-94 BOARDS (26273) / (732)-222-1511
Fax: (732)-222-7088 | E-mail: sales@touchboards.com

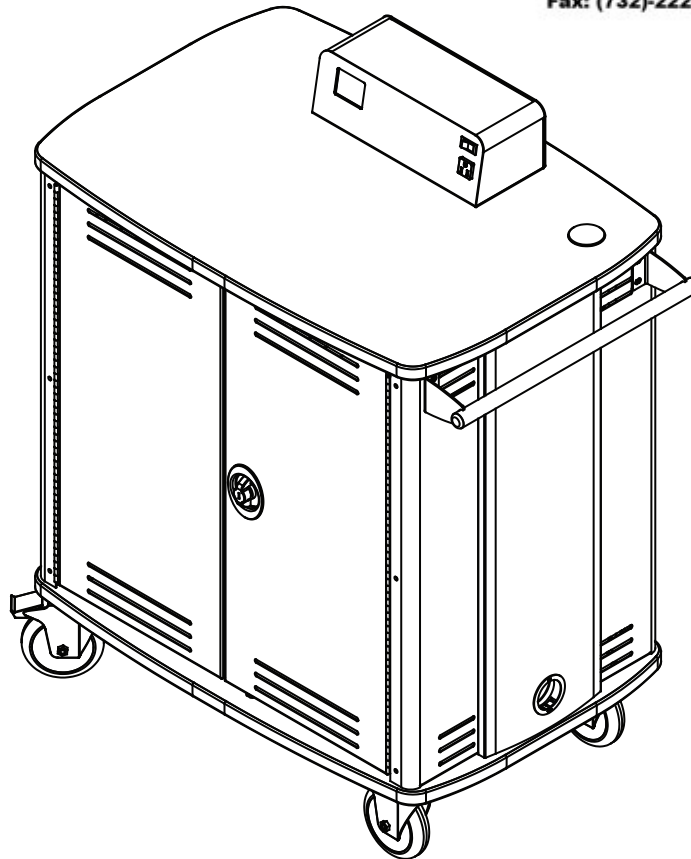

CAUTION:

Before using this product, read this manual and follow all safety and operating instructions.

Before you begin, please make sure all parts and proper quantities are included. Any parts damaged during shipment must be reported within 15 days of receipt. To report information regarding damages or if you have any questions, please call 1-800-235-1262.

To purchase parts or accessories, please contact us at
www.spectrumfurniture.com
1-800-235-1262
Thank you for purchasing Spectrum products!



Spectrum Industries, Inc
Chippewa Falls, WI 54729, USA



Safety



- Read this owner's manual before assembly or operation.
- Do not allow children to move cart.
- Move slowly and carefully when mobile.
- For indoor use only. Do not install or store the unit where it will be exposed to weather. Keep unit dry.
- For added safety, plug the unit into a grounded three-prong receptacle controlled by a GFI (Ground Fault Interrupter) circuit breaker.

Hardware Package Contents



(10) 052605
1/4-20 x 15mm JC bolts

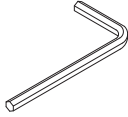

(1) 025039
4mm hex wrench

Tools Required

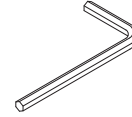

4mm hex wrench
(included)

Assembly / Setup

1. Handle Assembly

- Determine which side of the cart the handle is to be mounted.
- Attach the handle to the cart with (4) 1/4-20 x 15mm JC bolts and tighten securely. **Figure 1.**

Note: Attaching the handle on the same side of the cart as the 2 swivel balloon wheels will provide more control when the directional wheels are locked.

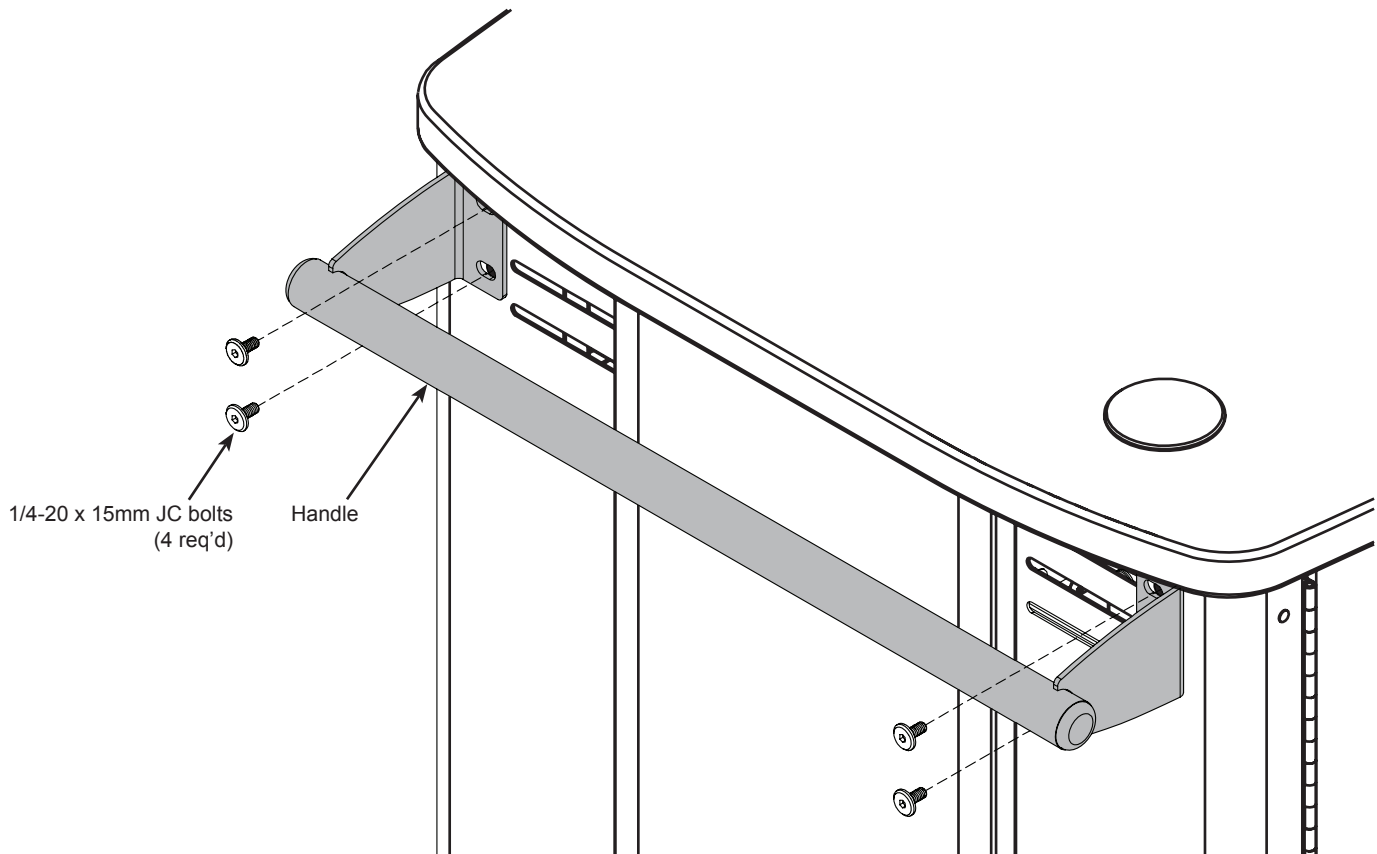

Figure 1

2. iPad Charger Wiring (student-side)

- A. Open the student-side doors.
- B. Place up to 40 iPads in the cart. Figure 2.
- C. Leave doors open.

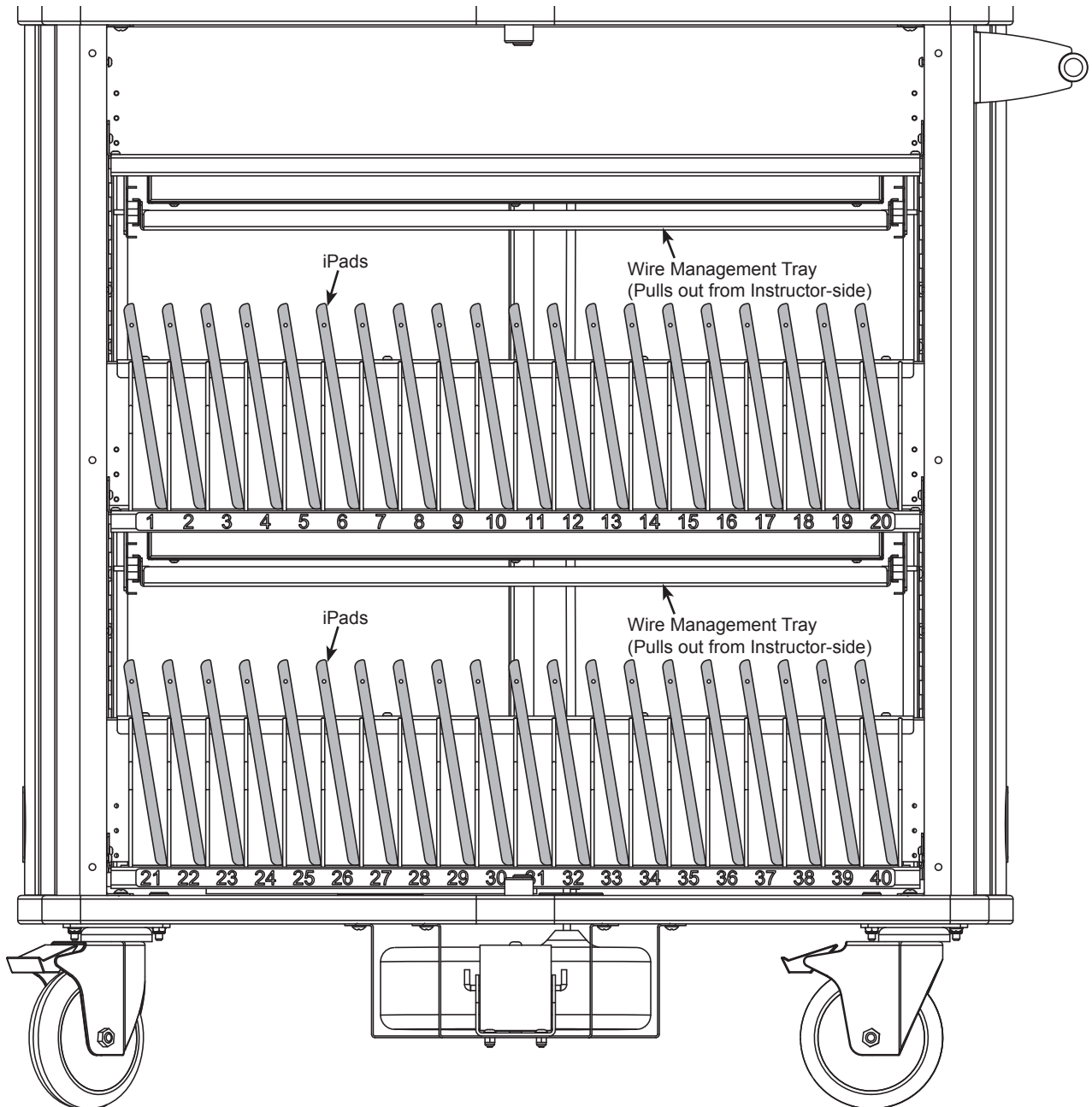

Figure 2

3. iPad Wiring (instructor-side)

- A. Open the instructor-side doors and pull out the wire management tray(s).
- B. Measure out the length of USB cord shown in **Figure 3A** for each iPad. (approximately 10-11")
- C. Insert the cord end (wide connector) through the opening in the tray and feed through the 10-11" of cord length. **Figure 3B.**
- D. Secure the cord to the tray and wrap excess using the cord management cutouts in the tray. Make sure 10-11" of cord length remains below the tray.
- E. Check the student side after the first wire is set to make sure each iPad can be plugged in without tension on the wire, then plug the USB cord into one of the USB ports located on the power unit above the tray.
- F. Continue this process with each remaining iPad.

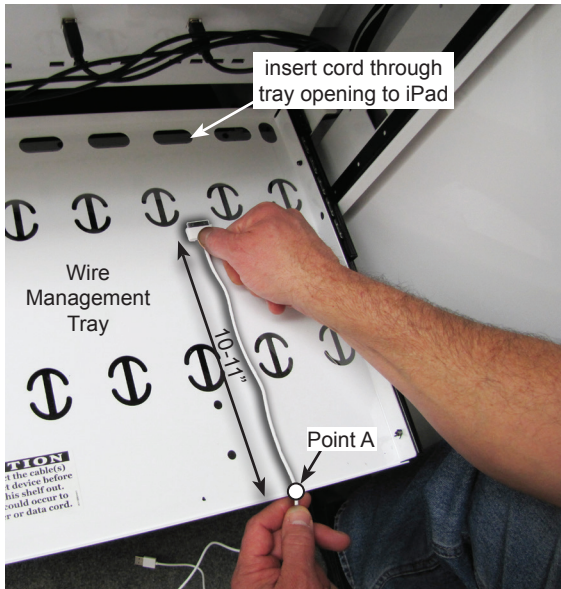

Figure 3A



Figure 3B

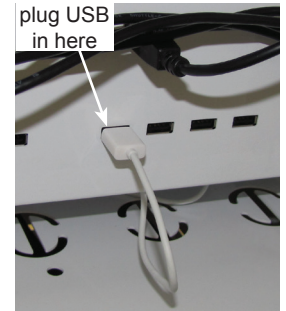

Figure 3C

- F. Repeat this procedure on the remaining iPad cords. **Figure 7D.**

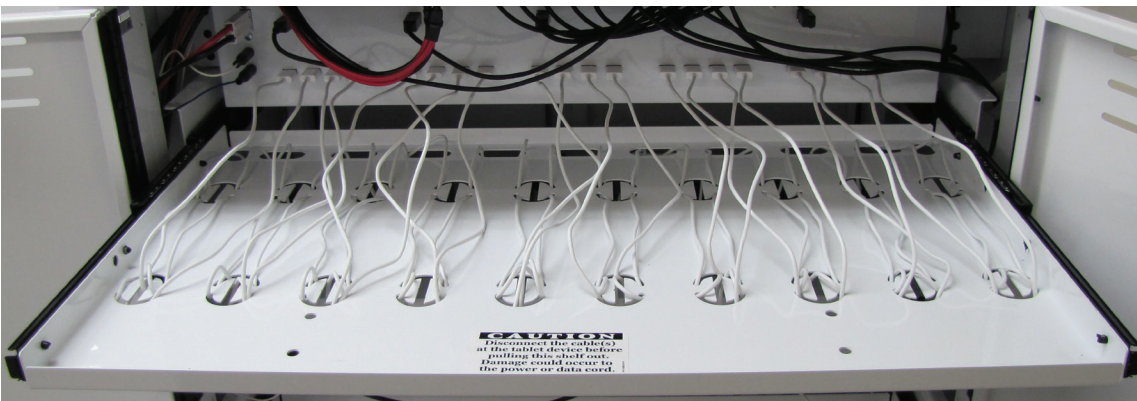

Figure 3D

- G. When the tray is closed, the cords on the student-side (opposite side) should look like **Figure 6E.**

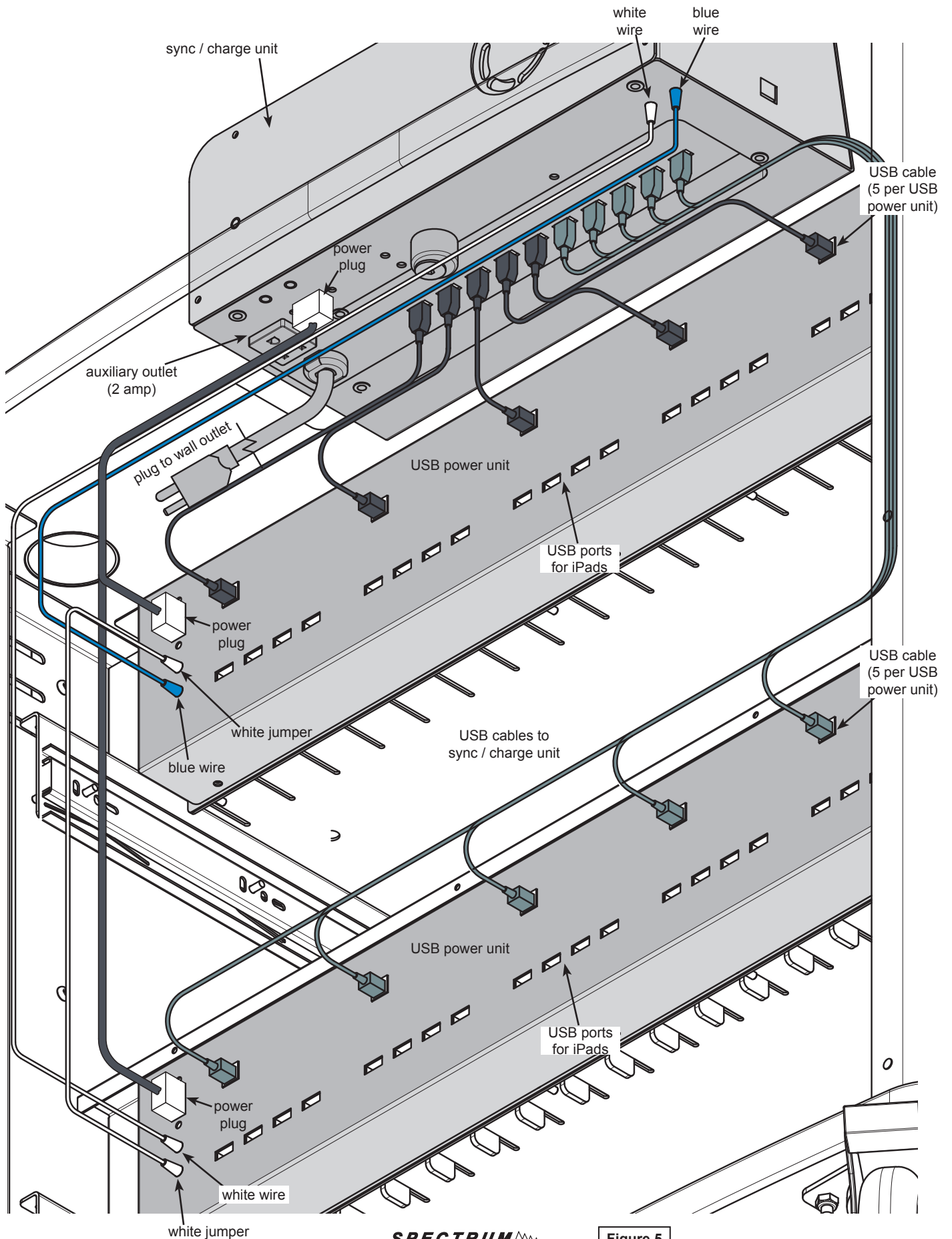

Figure 3E

CAUTION
 ALWAYS UNPLUG USB CORDS FROM iPADS **BEFORE** PULLING OUT AND ACCESSING WIRE MANAGEMENT TRAY.

wide connectors

Sync / Charge & USB Power Unit Wiring



Sync / Charge™ Unit

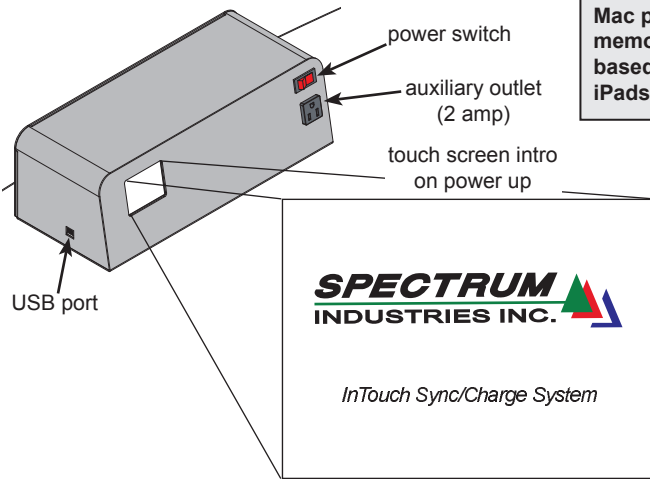

Note: For best syncing results, use an Apple Mac product as the host computer with enough memory to download to iPads. Windows-based products have limitations on quantity of iPads they can sync at one time.

Note: All cables should remain plugged in while power is present. If cables are removed and reconnected, the power must be reset to the host computer and cart.

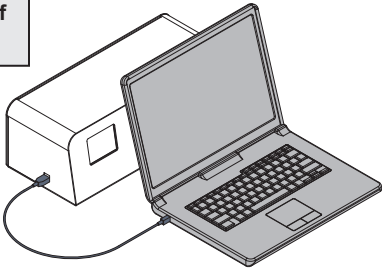

USB cable

Plugging a host computer USB cable into the side USB port at any time while the unit is powered on will cause the system to switch to Sync Mode. Unplugging the USB cable will return system to Charge Mode.

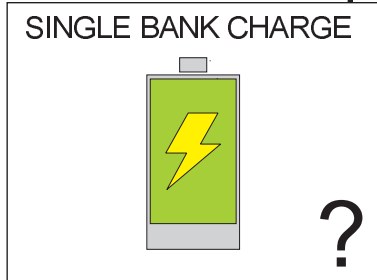

If only one bank is plugged in and detected (**InTouch 20 Cart**), the Single Bank Charge Mode is displayed until the host computer is plugged in.

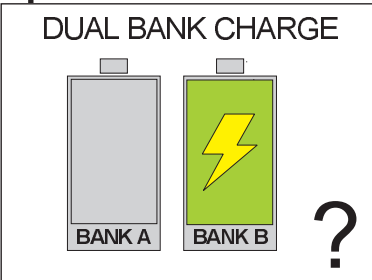

If two banks are plugged in and detected (**InTouch 40 Cart**), the Dual Bank Charge mode is displayed until the host computer is plugged in. Charging will cycle between banks at 15 minute intervals.

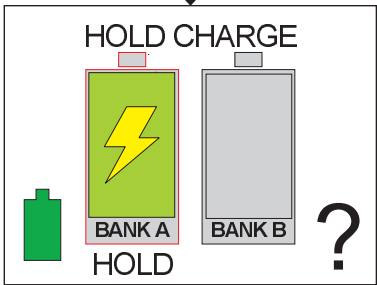

Press the 'A' or 'B' battery icon hold charge on either bank and discontinue cycling. Press the small battery (charge) icon to return to the Dual Bank Charge Mode.

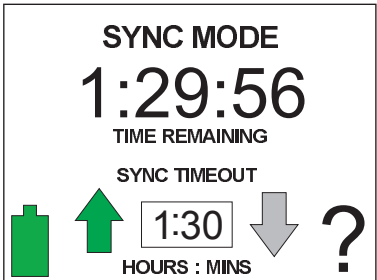

- Sync Mode Timer
- Syncs up to 40 iPads at once
 - Can be set from 30 min to 9.5 hrs by touching arrows (default setting: 30 min)
 - Shows countdown in minutes
 - Switches to Charge Mode after time expires or battery (charge) icon button is pressed

Note: Be sure to allow enough time on the automatic sync time-out for all downloading and syncing to be completed to iPad's.

CHARGE MODE HELP X

- Charges side A and B
- Push A to hold charge on side A
- Push B to hold charge on side B
- To enter SYNC MODE, plug in host computer
- Push small battery icon to return to Charge Mode.
- Further assistance call: 1-800-235-1262

To access the help screen, press ? in the lower right corner. When the help screen is displayed, the system remains on and continues operation in Charge Mode. Press X to return to the previous screen.

SYNC MODE HELP X

- SYNC TIMEOUT will switch to Charge Mode when time expires at indicated interval.
- Push small battery icon to return to Charge Mode Manually.
- Further assistance call: 1-800-235-1262

To access the help screen, press ? in the lower right corner. When the help screen is displayed, the system remains on and continues operation in Sync Mode. Press X to return to the previous screen.

Divider Panel Removal

The divider panels can be removed or reconfigured to accept a wide variety of iPads and devices.

- To adjust or remove the dividers, use a Phillips screwdriver to remove the (4) 8-32 x 1/2" PHM screws securing the divider stop bracket. **Figure 6.**
- Adjust / remove the dividers as necessary.
- Replace the bracket and PHM screws. Tighten screws securely.

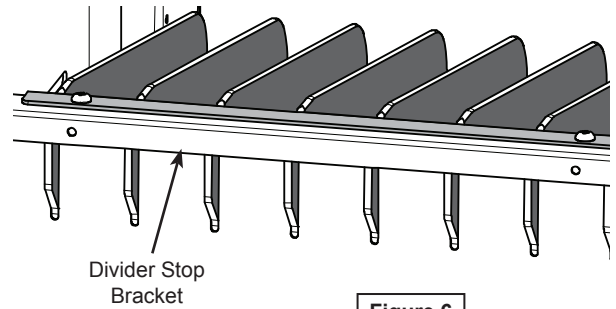

Figure 6

Wheel Operation

Two directional, swivel locking 5" directional balloon wheels are provided and can be rotated and locked at 180° intervals to be rigid, or unlocked to be swivel. This provides control when transporting between classrooms, while allowing maneuverability in tight spaces.

- To lock the wheel direction, align each wheel with the cart width and depress the brake lever. **Figure 7.** (Each wheel can be locked at 180° intervals)
- To resume swivel operation, unlock each brake lever.

Note: Wheel rotation cannot be locked on directional wheels. To prevent the cart from rolling, lock the standard locking balloon wheels on the other side of the cart.

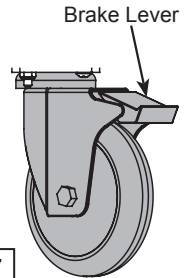

Figure 7

Door Stop Adjustment

If necessary, the offset door stop can be rotated slightly to adjust the closed position of the doors and lock rods.

- To rotate, loosen the JC bolt slightly with a 4mm hex wrench. **Figure 8.**
- Rotate the door stop until the door is positioned correctly.
- Re-tighten the JC bolt securely.

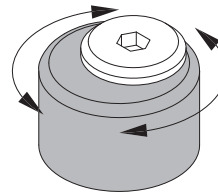

Figure 8

Cord reel operation (#55438 only)

Operating Instructions:

- To latch cord - Pull cord out to full length. Allow the cord to retract 1-2 feet back into the reel. Pull the cord out slowly. When a 'click' is heard, the cord will latch in place.
- Plug into 110-125V (single phase), 3-conductor wall outlet.
- To release cord - Unplug from wall outlet. Pull cord out slowly until clicking stops. The latch will release and the cord can be guided back into the reel. Do not allow the cord to fly unrestricted back into the reel.
- Do not overload or circuit breaker (15-amp maximum) will cut off current. To restore power, remove overload, wait two minutes, then reset the circuit breaker by pressing the button on the back of the 3-prong male power plug.

Maintenance:

- Remove dirt and grime as soon as it accumulates on the reel case by using a soft, damp cloth (a mild detergent may be used if needed), being careful not to wet the electrical plug. Never immerse any part of the unit in any solution to clean. **DO NOT** use solvents such as gasoline, turpentine, etc. to clean unit.
- Keep cord clean to assure smoothest automatic retraction. Simply pull cord to its full length and allow to retract through a dampened rag. Pull out full length again and sprinkle cord with talcum powder.

Specifications:

15' retractable, 15-amp, 125V, 12 AWG with breaker, UL listed

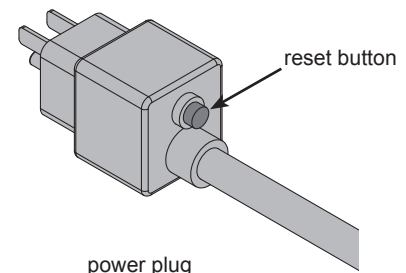
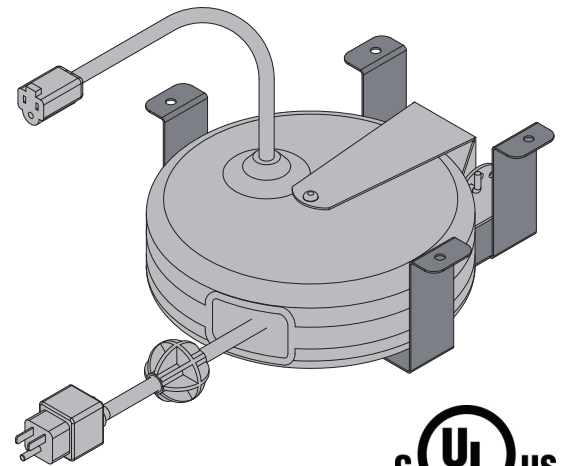

WARNING

- This cord reel is intended for general indoor use only. It is not intended to be used in potentially dangerous locations such as flammable or explosive atmospheres. The reel is not waterproof and not intended for use in potentially wet locations.
- Do not overload (15-amp maximum).

Moving the cart

1. Before moving the unit, unplug all power cords and wrap power cord or retract power cord into the reel (if equipped).
2. Be sure the casters are in the unlocked position and the doors closed.
3. Move the cart slowly and carefully.
4. Lock the casters after moving.

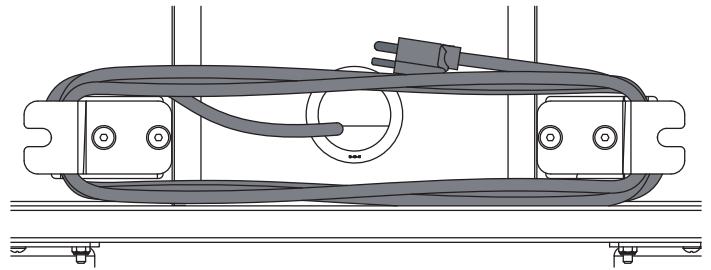

Figure 9



WARNING



ATTENTION









CAN TIP OVER RESULTING IN RISK OF INJURY, DO NOT ALLOW CHILDREN UNDER 16 TO MOVE CART. MOVE CART SLOWLY.

PEUT BASCULER, ENTRAINANT UN RISQUE DE BLESSURE, NE LAISSEZ PAS LES ENFANTS DO MOINS DE 16 POUR DEPLACER PANIER. DEPLACER PANIER LENTEMENT

ONLY ADULTS SHOULD MOVE THIS UNIT

SEULS LES ADULTES DEVRAIENT PASSER CET APPAREIL

APPLY MOVING FORCE ON NARROW DIMENSION

APPLIQUER UNE FORCE EN MOUVEMENT SUR LA DIMENSION

NEVER APPLY FORCE AT TOP ALWAYS PUSH NEAR MIDDLE

JAMAIS EMPLOYER LA FORCE EN HAUT TOUJOURS POUSSER PRES DU MILIEU

PUSH, DO NOT PULL

POUSSER, NE TIREZ PAS

Options

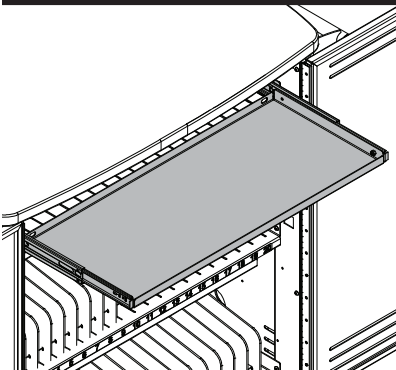

Pull-out Instructor Shelf
(for instructor laptop or storage)
25⁷/₁₆"W x 11³/₈"D x 3¹³/₁₆"H
55442

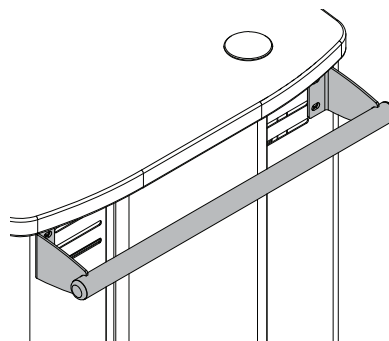

Additional Steel Handle
(mounts on left or right-max 2 per unit)
20³/₁₆"W
55393



Replacement Key Set
55142

Troubleshooting

Note: For best syncing results use a high-powered Apple Mac product as host computer when downloading your files to the iPads through Apple Configurator software.

Symptom	Problem	Solution
On / off switch does not light up, and/or touch screen remains off	No power to control box or system has exceeded 15-amp breaker capacity.	Make sure all power cords are connected and plugged into a 'hot' wall outlet. Turn on/off switch off and back on to reset breaker. Power cord reel also has a breaker button on the end of the cord. Push button to reset.
On / off switch lights up but touch screen remains off, or no power to USB ports when charging.	Faulty touchscreen or connection inside sync / charge unit	Call Spectrum
Charging bank of 20 iPads: Only one bank receiving power during charge cycle	Possible loose USB connections	Check all connections from the sync / charge unit to each bank of 20 ports-see Figure 5 . Also check all USB connections from each bank to each iPad to be sure the USB cables are fully plugged-in.
Neither bank seems to be getting power but touch screen status shows power is cycling.		
Syncing: After host computer is connected, software senses and shows fewer iPads than are connected		
Slow / interrupted downloads or system seems to be "thinking"	Low battery or memory in host laptop prevents efficient downloading	Be sure host computer is fully charged, or use a faster host computer.
Can only sync 7-8 iPads at a time	Using a windows-based laptop to sync iPads	Use an Apple product as host computer.
Only one or a few iPad(s) fail to report connectivity	iPad is not charged	Be sure all iPads have a charge or are charging. If not charged, set 1/2 hr for automatic cycle charging to provide enough charge to allow time to sync. If charging, wait a few minutes for iPad to report.
	Loose or defective USB cable	Completely unplug and plug back in USB cable from device and cart. If issues persist, switch with a new, or known operational cable.
	Corrupted iPad (Plug directly into host computer to test.)	Unplug iPad. Hard boot (completely power cycle) device. Re-connect iPad to cart.
Touch screen flashes and continually resets	Power connections to the top sync / charge unit. (Power and/or blue & white data cables loose or defective)	Check all power cables in back of unit for connectivity. Unplug cart from power source at wall. Unplug and re-plug-in power cables, and white / blue wires. Plug cart back into power at wall and restart system.

Warranty

WE WILL MAKE IT RIGHT FOR YOU!

Spectrum is committed to provide complete customer satisfaction. Each of our products are manufactured from the best materials available and each product is stringently monitored throughout the production process through our P.A.C.E. program (Product Assurance to meet Customer Expectations). Our Customer Service Help Line 1-800-235-1262 is ready to provide immediate attention to any questions, comments or concerns. We are available to answer your calls Monday through Friday from 7 am to 5 pm CST, excluding observed holidays. In addition your product comments or concerns are welcome via e-mail at: spectrum@spectrumfurniture.com.

Warranty Statement

We guarantee all Spectrum products to be free of all defects in materials and workmanship, for the original owner, for a period of ten years. Any item deemed defective by Spectrum or the original manufacturer, under normal use conditions, will be repaired or replaced at Spectrum's discretion. This warranty applies to all products manufactured and distributed by Spectrum except the products listed below.

Items that have a varying warranty include, but are not limited to, the following:

- Adjustable Crank/Electric Desk Legs (1 yr)
- Flat Panel Desk Gas Cylinders (1 yr)
- Upholstered Soft-Goods (5 yrs)
- Adjustable Height & Stacking Chair Parts – including frames, gas cylinders, wood and plastic parts, and control handles (7 yrs)
- Adjustable Height & Stacking Chair Casters (2 yrs)
- Chair Upholstery & Textiles (2 yrs of normal use of Soft Goods, Adjustable Height, Stacking, Wood and Metal Chairs)
- Chair Upholstery - Graded-In Fabrics and C.O.M (no warranty)
- Height Adjustable Columns and Lifts (1 yr)
- General Use Casters (1 yr)
- Electrical – Electri-Pak, Power Communication Modules, and special order ECA electrical items (1 yr)
- Electrical - Power Strips & Electrical Timers (1 yr)
- Electrical Surge Suppressors (lifetime)
- Electrical - Retractable Power Cords (1 yr)
- Keyboard/Mouse Trays (1 yr)
- Flat Panel Monitor Arm – General Parts (5 yrs)
- Flat Panel Monitor Arm – Gas Cylinders (2 yrs)
- CRT Monitor Arm (1 yr)

Warranty is void if product is not used for its intended purpose or subjected to an unusual application, multiple-shift use, alteration, accident, abuse or abnormal wear and tear. Representations of colors on-line and in printed materials are meant to be a close reference to the actual colors but not an exact match. Slight variations in color and texture of wood stains, powder coating, laminates, fabrics and other materials are normal in different manufacturing lots; as such these variations are not considered defects.

DESIGNED FOR INDOOR USE ONLY – Unless specifically stated in the product specifications, Spectrum's products have been designed and constructed for indoor use only. Moving or using outdoors, or on excessively rough surfaces, may cause damage to the products and will void the warranty. If an outdoor application is desired please contact us to discuss potential custom design solutions.

The warranty, as stated above, supersedes any previous warranties and is effective as of 9/1/2010

Touchboards

205 Westwood Ave, Long Branch, NJ 07740
Phone: 866-94 BOARDS (26273) / (732)-222-1511
Fax: (732)-222-7088 | E-mail: sales@touchboards.com

