



EVO® 5900

EVO® provides ergonomics and space savings in a sleek monitor arm. EVO® offers one-touch monitor adjustment and unique Better Balance® Technology to provide true constant force across the arm's entire range of motion. It's easier than ever to mount a flat panel monitor while complementing any workspace with EVO's modern design.



reddot award 2017 winner



FEATURES

- Effortlessly reposition with one-touch monitor adjustment.
- Tension adjustment at each joint.
- Easily rotate flat panel monitor for portrait or landscape viewing.
- Mount installation is performed above desk for quick and easy set-up.
- Sleek cable management system routes cables beneath the monitor arm.
- Durable, quick-install VESA adapter reduces installation time.

AVAILABLE OPTIONS

5900 Supports a 1 - 12 lb (0.5 - 5.4 kg) monitor

FINISHES

FLAT WHITE | color code: **248**

SILVER | color code: **124**

VISTA BLACK | color code: **104**



CAPABILITIES

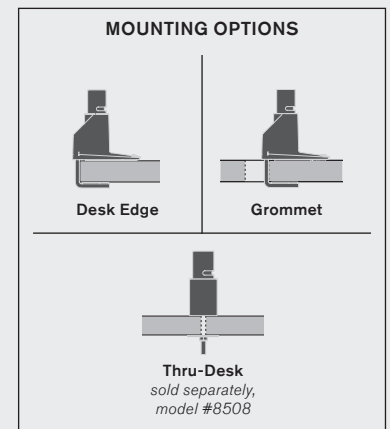
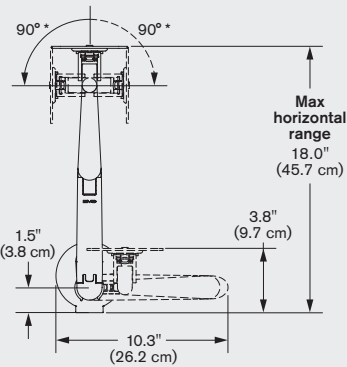
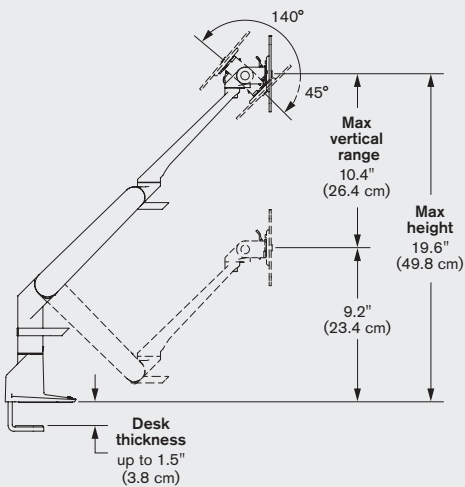

* Joint is capable of rotating 360 degrees, but size of monitor will limit the rotation.

© 2017 Innovative Office Products, LLC



800.531.3746 • info@thehumansolution.com • thehumansolution.com



EVO® 5902

The Dual EVO® monitor mount utilizes our EVO® monitor arm in a dual monitor desk mount application. The monitor arms provide intuitive function and dual monitor rotation for easy, ergonomic viewing of both screens.

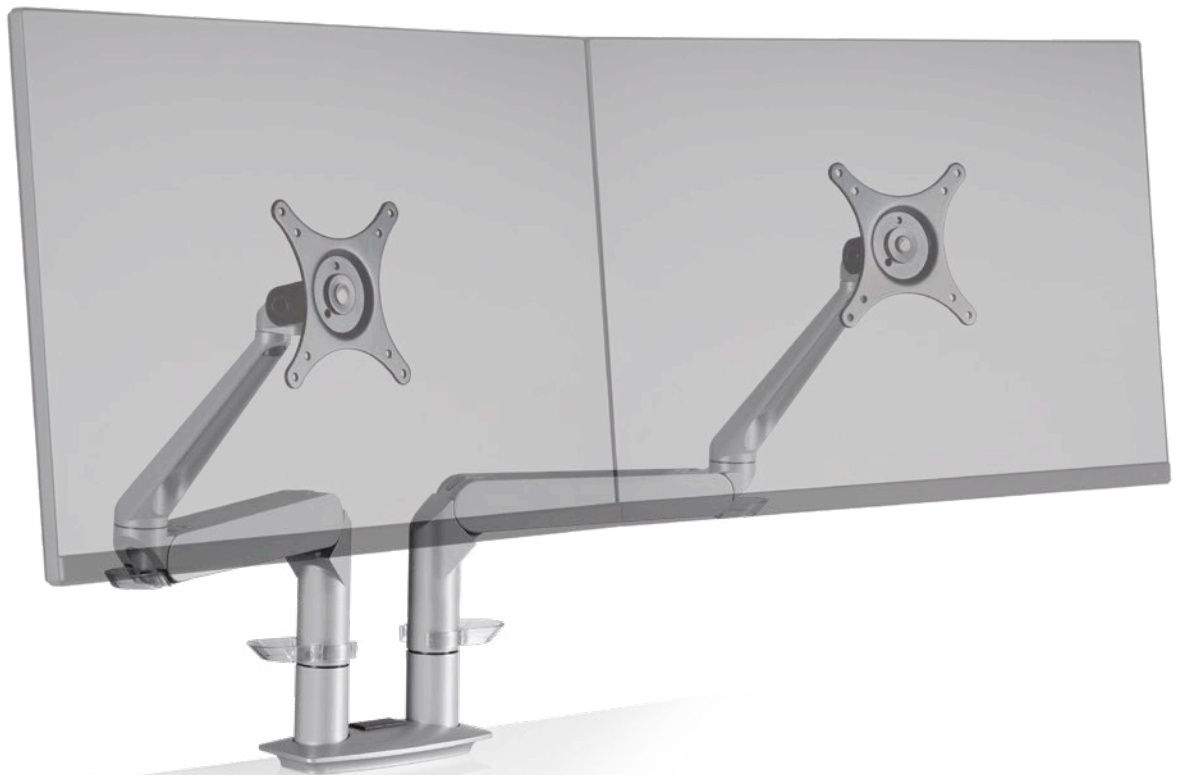

FEATURES

- Extremely flexible positioning of dual flat panel monitors.
- Ease-of-use encourages users to work with their dual monitors ergonomically.
- Rotate dual monitors for portrait or landscape viewing.
- Tension adjustment at each joint.
- Mount design includes a cable management system that routes cables beneath the monitor arm.
- Durable, quick-install VESA adapter reduces installation time.

AVAILABLE OPTIONS

5902 Supports 1 - 15 lbs (0.5 - 6.8 kg) per monitor, up to 27"

FINISHES

FLAT WHITE | color code: **248**

SILVER | color code: **124**

VISTA BLACK | color code: **104**



CAPABILITIES

