

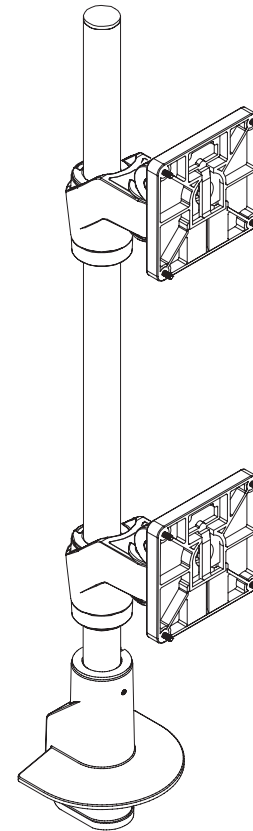

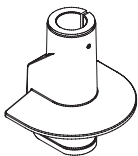

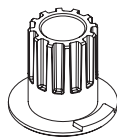







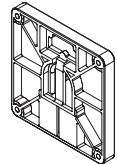

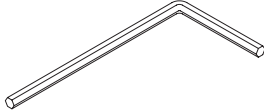
**STX-01S**

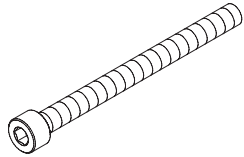
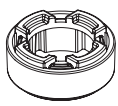
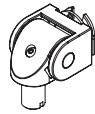
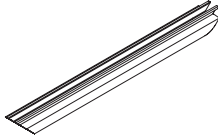
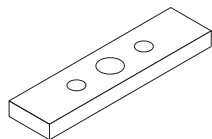

**STX-11S**

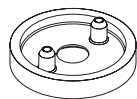
# PARTS LIST

<p>A</p> <p>Top Down Mount 8524</p> 	<p>F</p> <p>Bushing Adapter 112945</p> 	<p>K</p> <p>10-32 x 3/8" FPhMS w/Lock Patch 705198</p> 	<p>P</p> <p>3/32" Allen Wrench 700146</p> 
<p>B</p> <p>Dimpled Pole 110607-14</p> 	<p>G</p> <p>Quick Connect VESA Plate 114808</p> 	<p>L</p> <p>Pole Cap 105195</p> 	<p>Q</p> <p>7/32" Allen Wrench 701127</p> 
<p>C</p> <p>Stackable Mount 413054</p> 	<p>H</p> <p>M6 x 1mm Phillips Pan Head Screw 701153</p> 	<p>M</p> <p>Cable Clip 104533</p> 	<p>R*</p> <p>M8 x 95mm SCHS 716061</p> 
<p>D</p> <p>Pole Collar 113332</p> 	<p>I</p> <p>Monitor Tilter 8500 Tilter</p> 	<p>N</p> <p>Cable Cap 114810</p> 	<p>S*</p> <p>Spacer 701544</p> 
<p>E</p> <p>Pole Clip 113449</p> 	<p>J</p> <p>Dog Washer 105189</p> 	<p>O</p> <p>1/8" Allen Wrench 701312</p> 	<p>T*</p> <p>Lock Nut 710015</p> 

## DESK EDGE CONFIGURATION

1

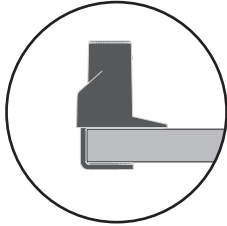

Desk thickness  
up to 1.5" (3.8 cm)

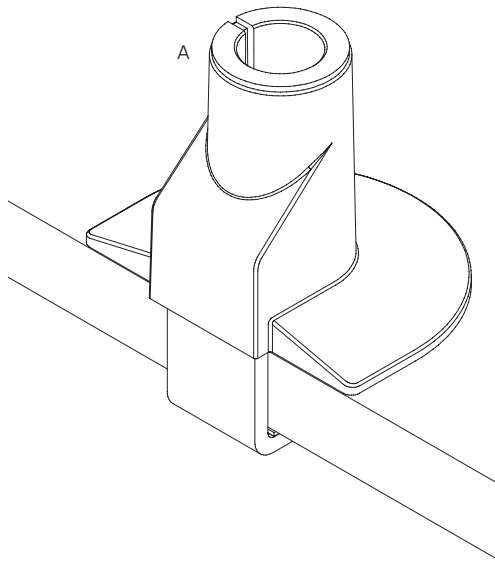

OR

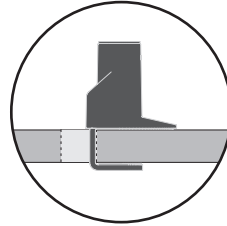

Desk thickness  
up to 1.5" (3.8 cm)

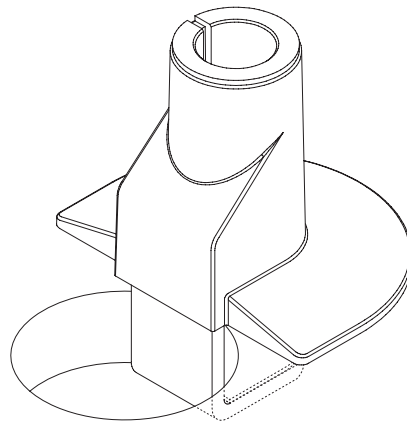

2

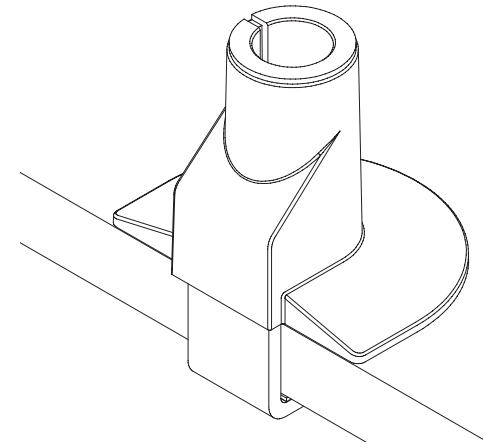
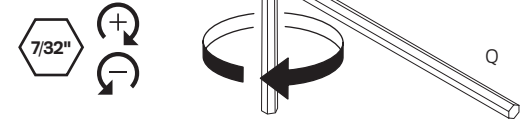

If the monitor arm or pole does not easily fit into the mount, remove the bushing from the mount and place it on the monitor arm or pole and press firmly back into the mount.

2a

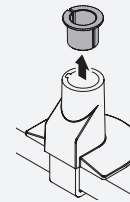

2b

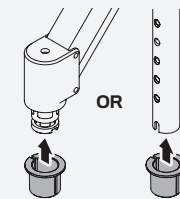

2c

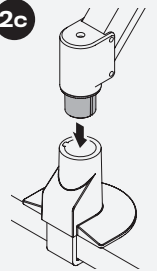

THRU-DESK CONFIGURATION\*

3

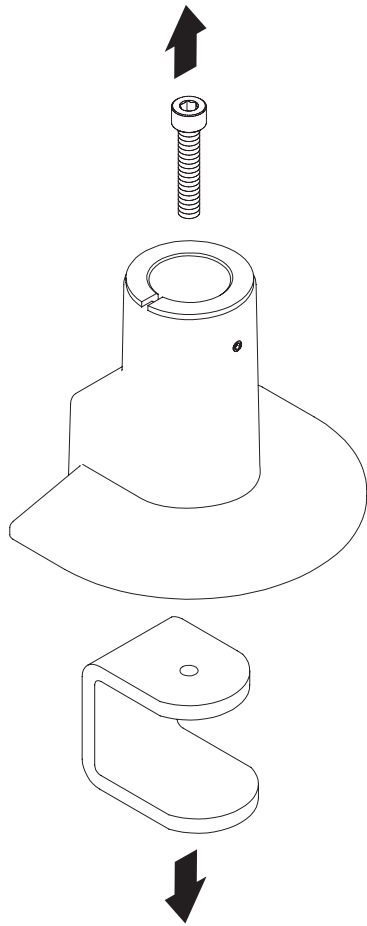

4

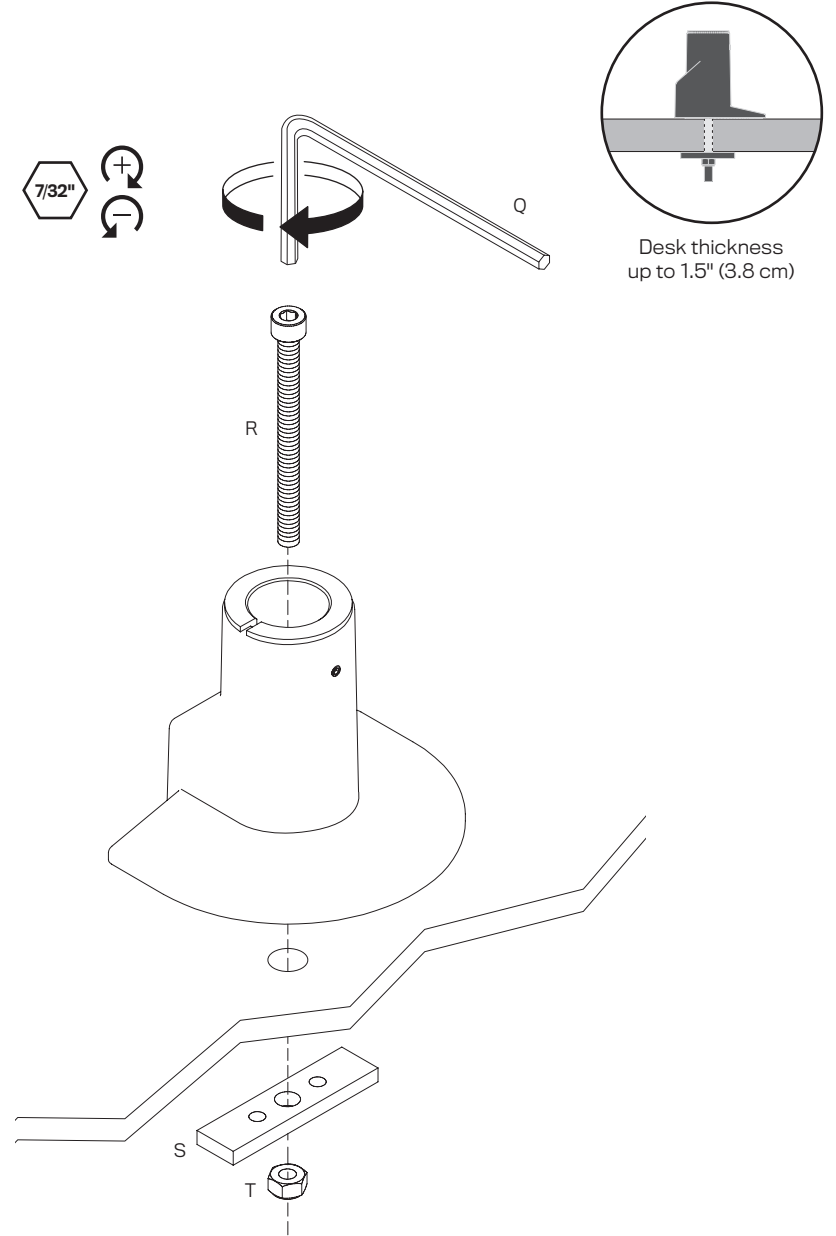

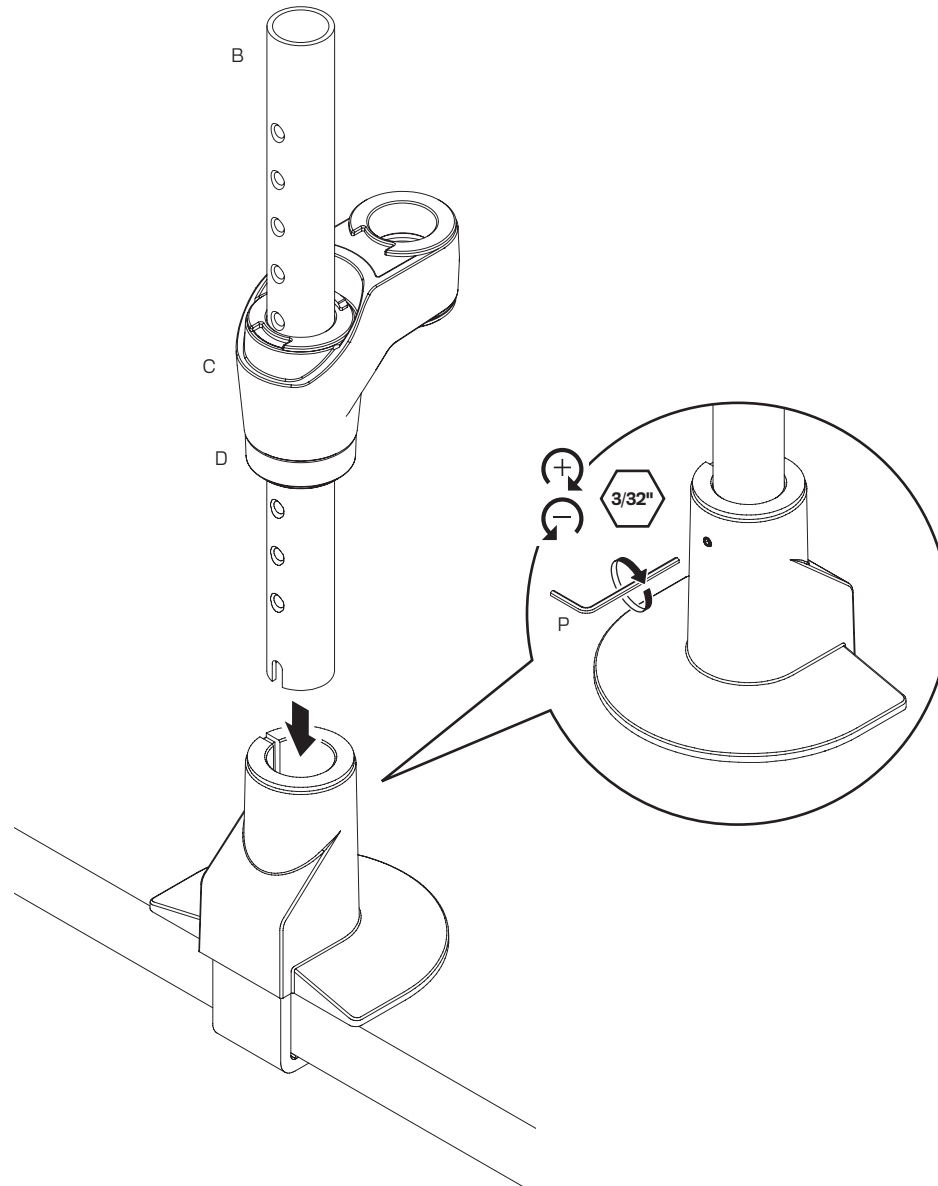
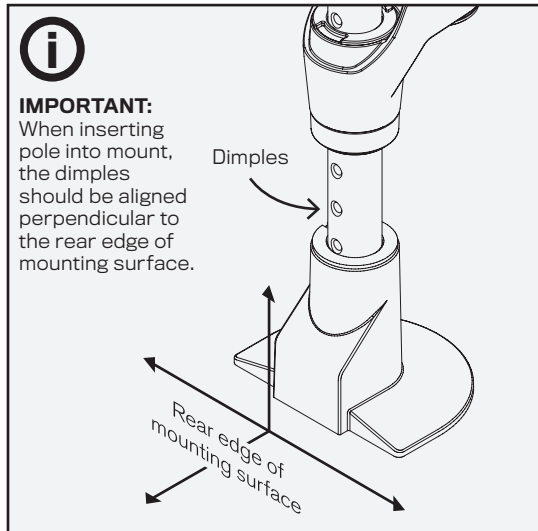

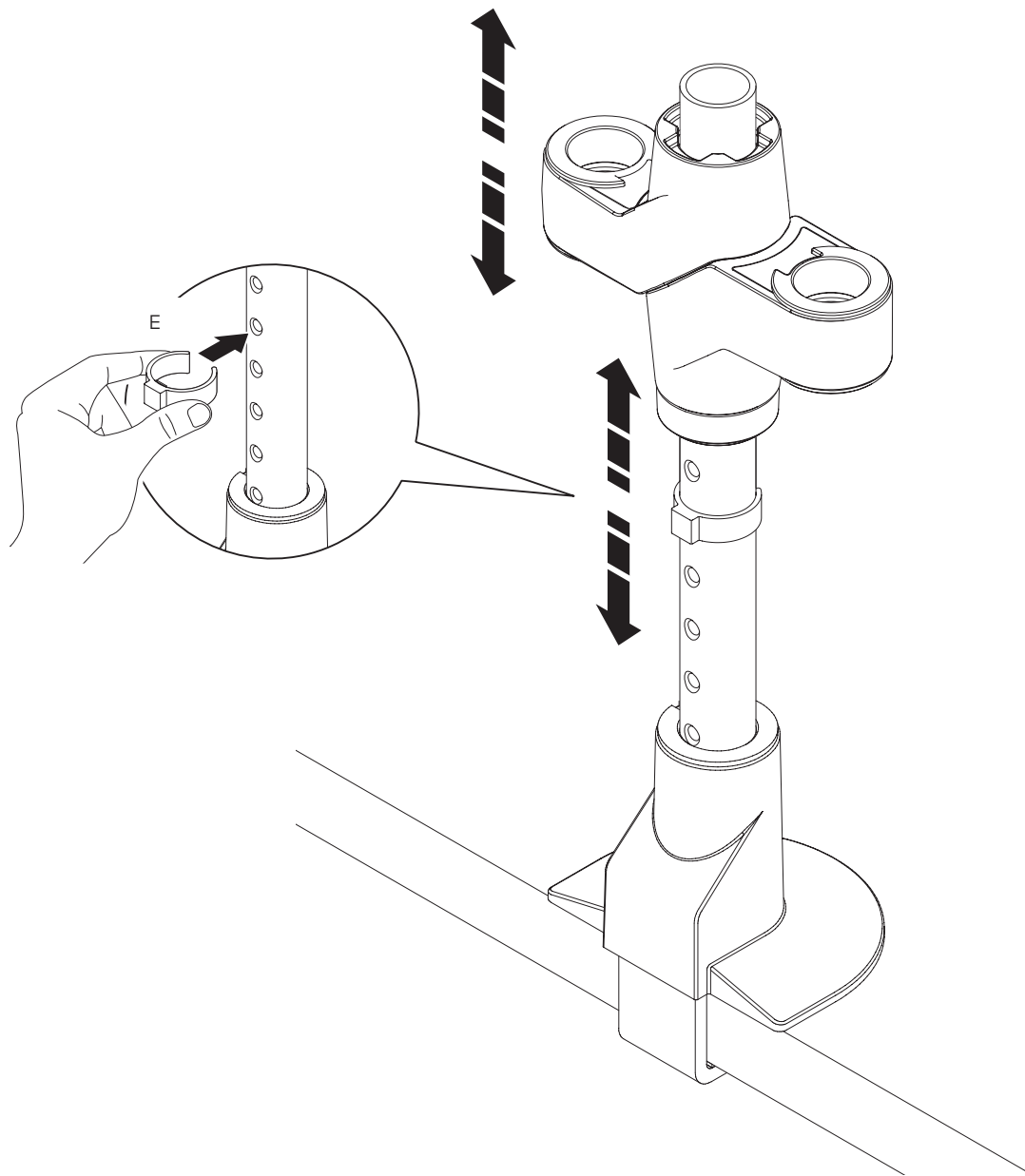

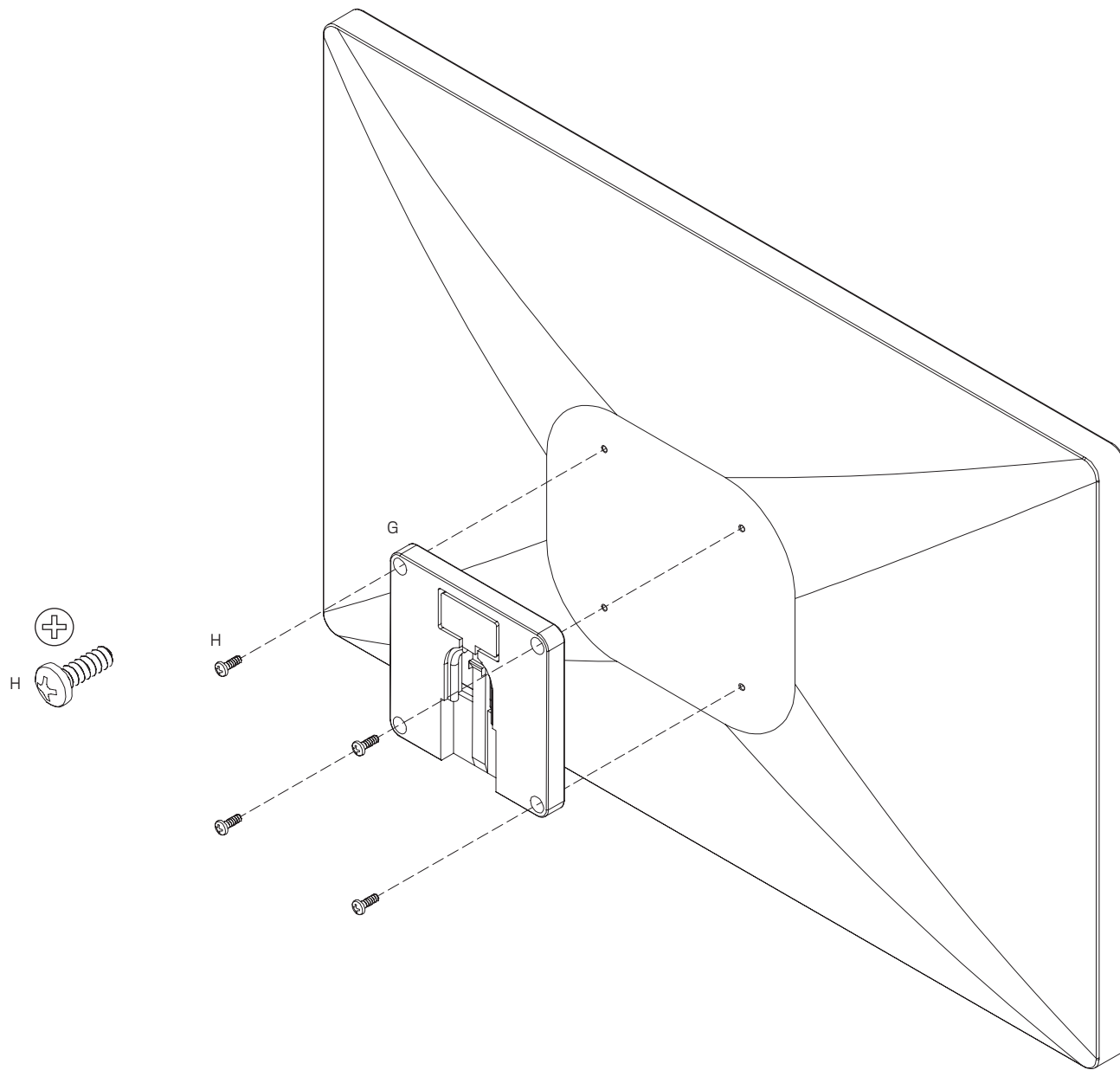

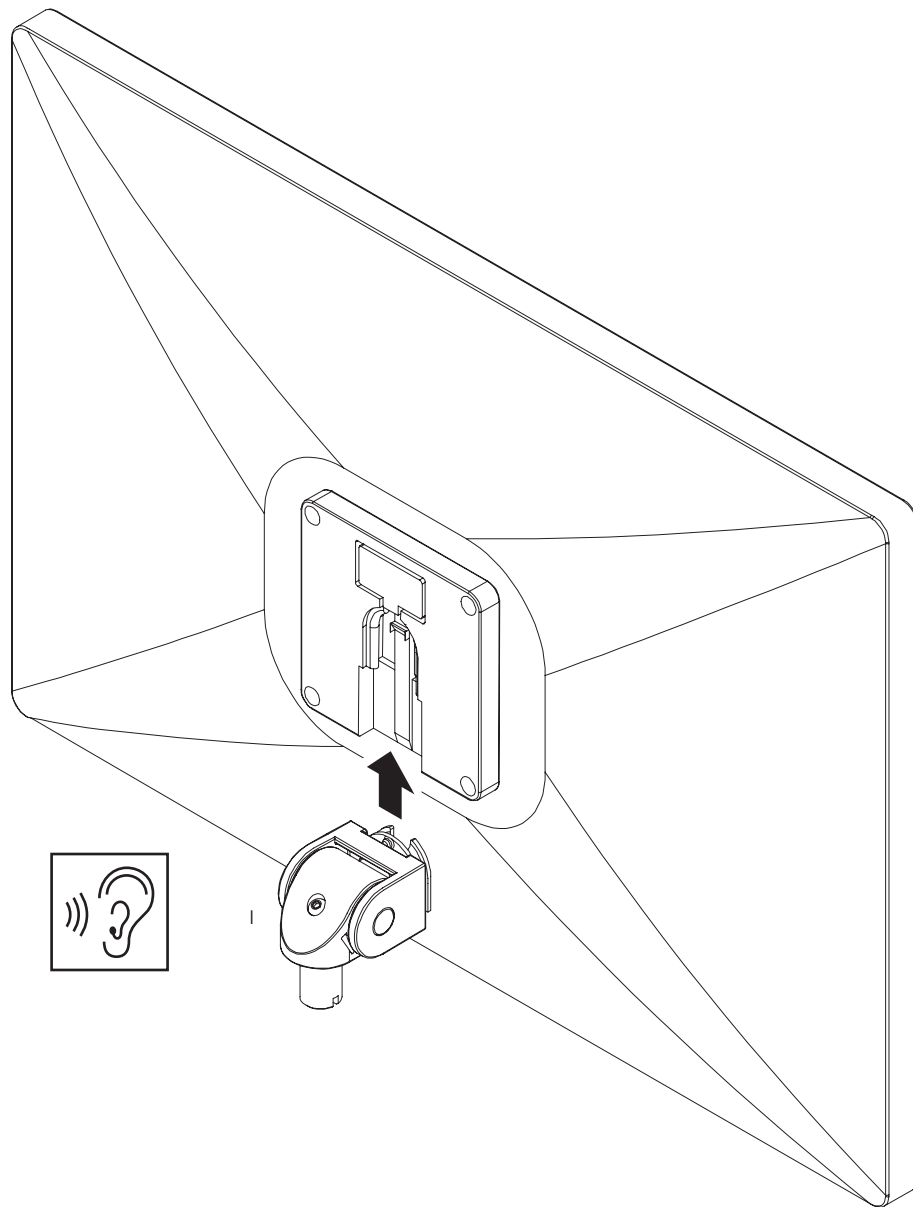



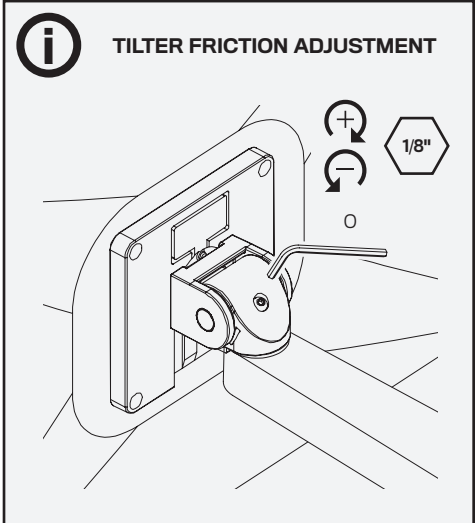
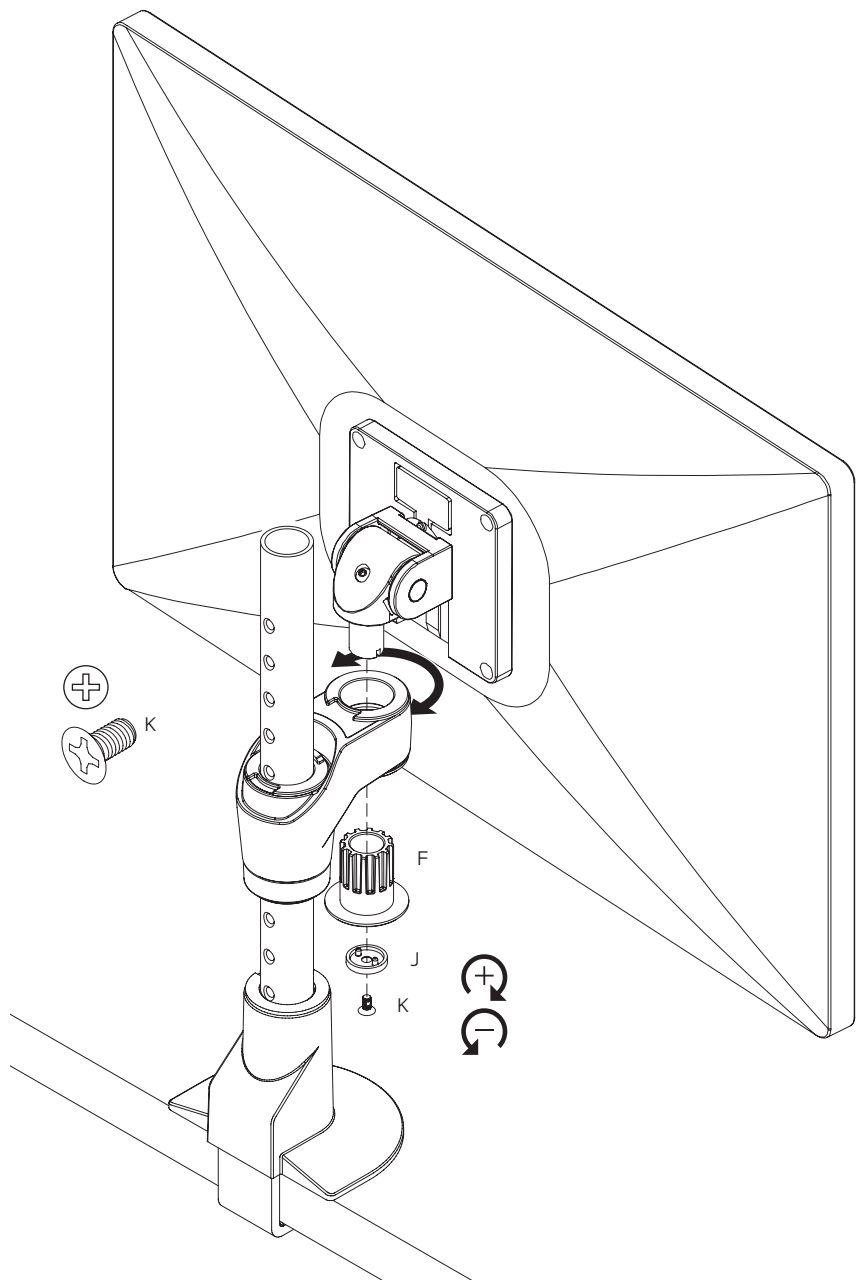

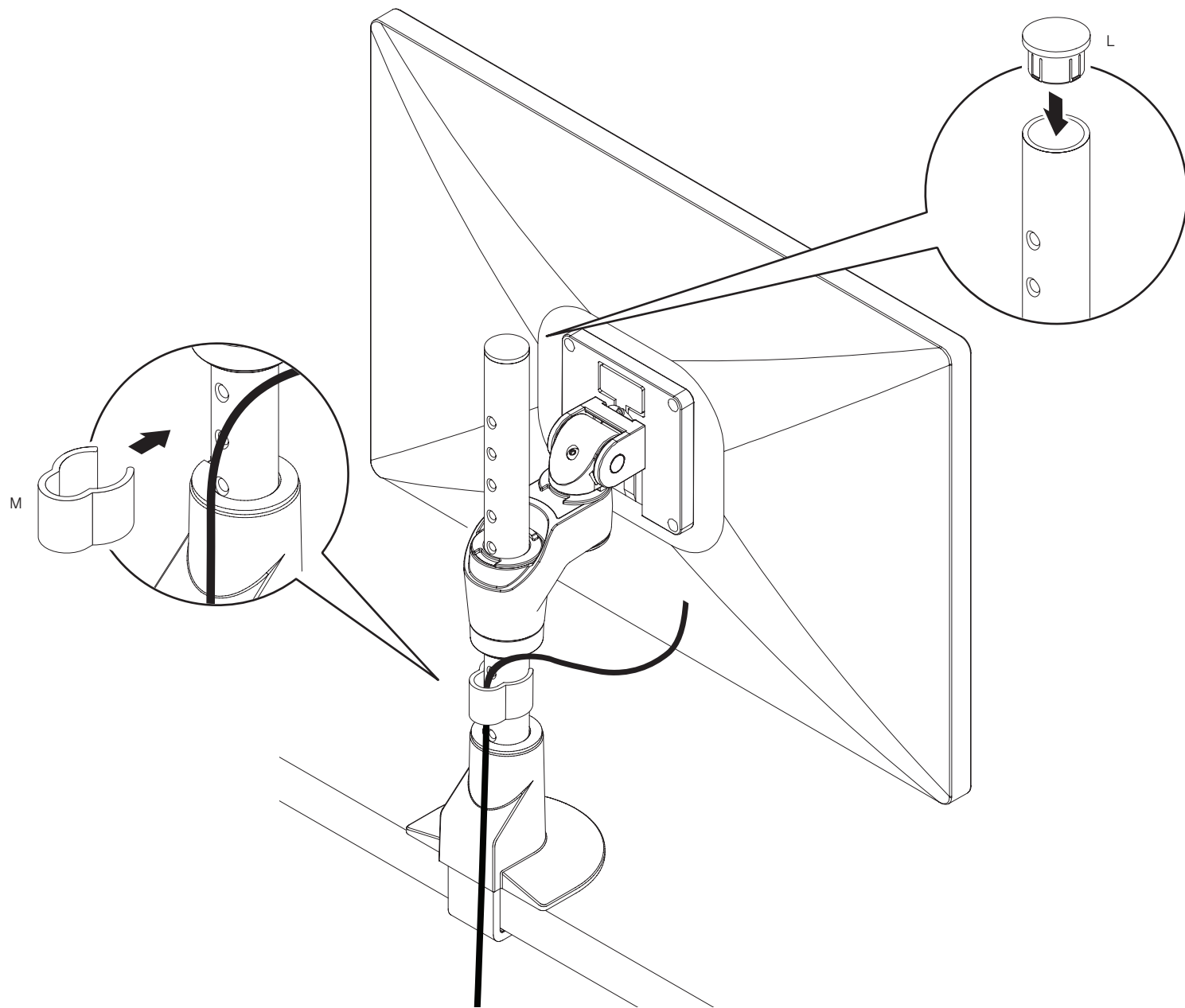

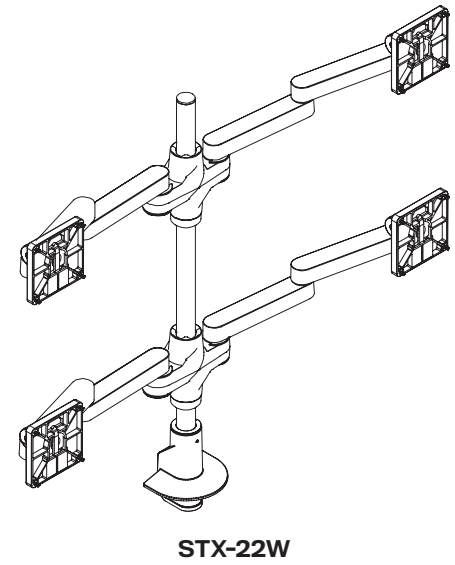
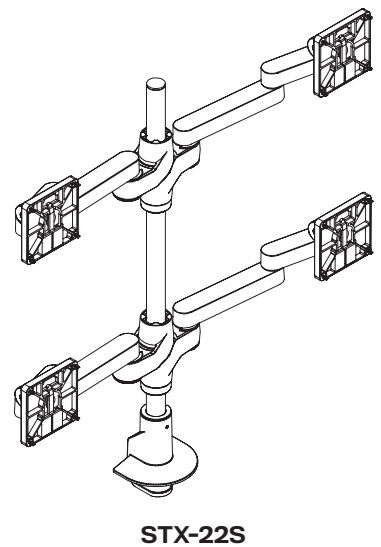
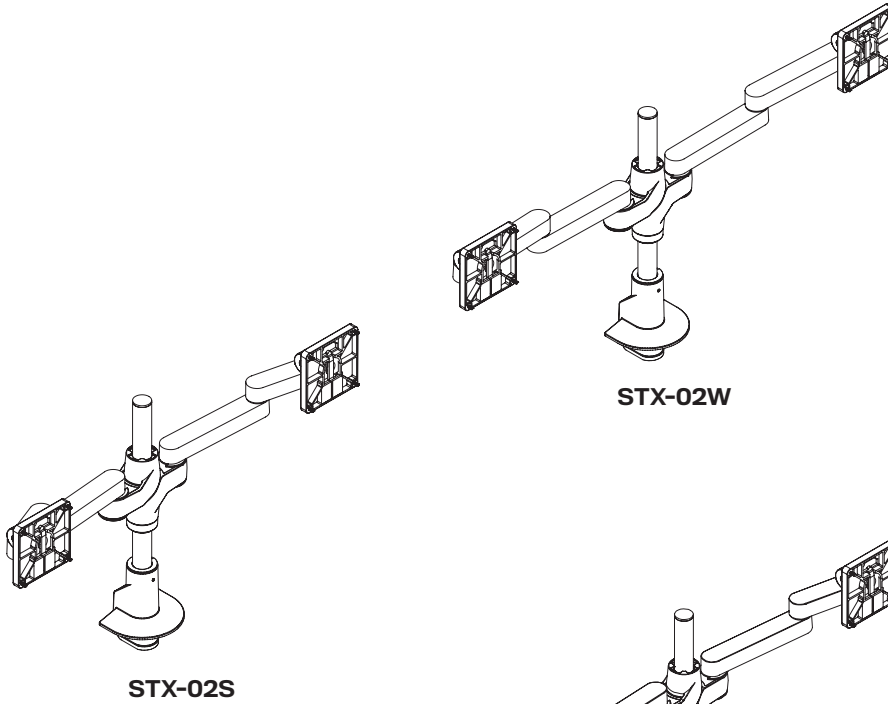



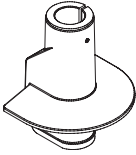
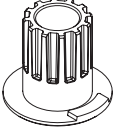

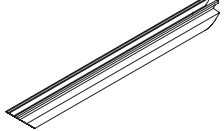
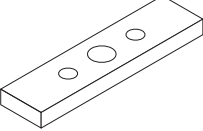

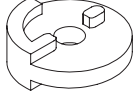
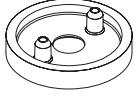





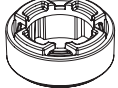
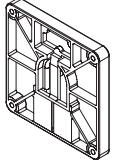

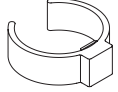
# PARTS LIST

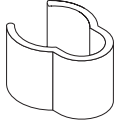
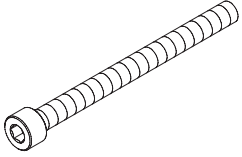
<p>A Top Down Mount 8524</p> 	<p>F Bushing Adapter 112945</p> 	<p>K Monitor Tilter 8500 Tilter</p> 	<p>P Cable Cap 114810</p> 	<p>U* Spacer 701544</p> 
<p>B Dimpled Pole 110607-14</p> 	<p>G Rotation Stop for Extension Arms 113703</p> 	<p>L Dog Washer 105189</p> 	<p>Q 1/8" Allen Wrench 701312</p> 	<p>V* Lock Nut 710015</p> 
<p>C Stackable Mount 413054</p> 	<p>H 10-32 x 5/8" Phillips Pan Head Screw 702200</p> 	<p>M 10-32 x 3/8" FPhMS w/Lock Patch 705198</p> 	<p>R 3/32" Allen Wrench 700146</p> 	
<p>D Pole Collar 113332</p> 	<p>I Quick Connect VESA Plate 114808</p> 	<p>N Pole Cap 105195</p> 	<p>S 7/32" Allen Wrench 701127</p> 	
<p>E Pole Clip 113449</p> 	<p>J M4 x 12mm Phillips Pan Head Screw 701153</p> 	<p>O Cable Clip 104533</p> 	<p>T* M8 x 95mm SCHS 716061</p> 	

# DESK CLAMP CONFIGURATION

1

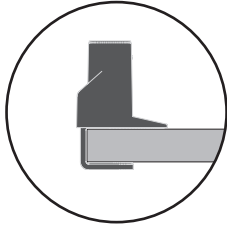

Desk thickness  
up to 1.5" (3.8 cm)

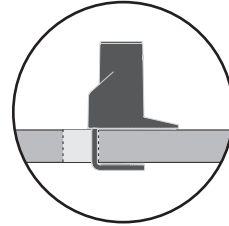
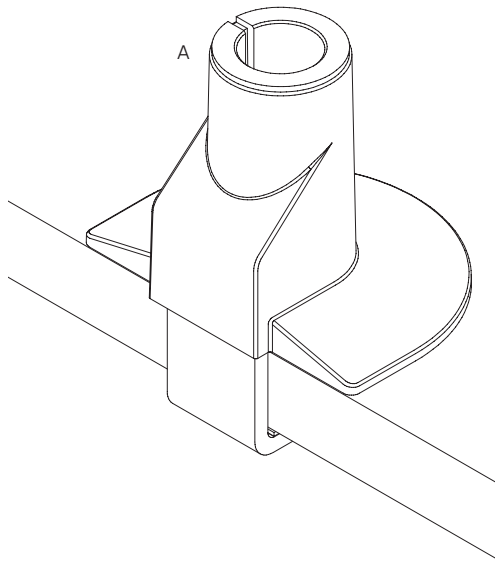

Desk thickness  
up to 1.5" (3.8 cm)

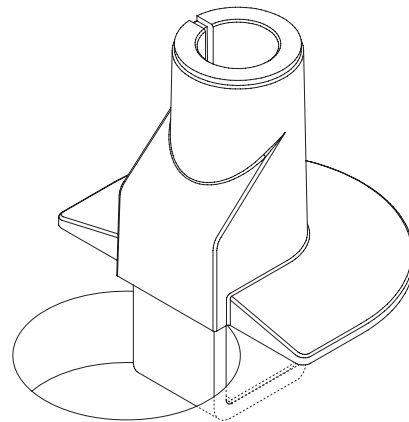

OR

2

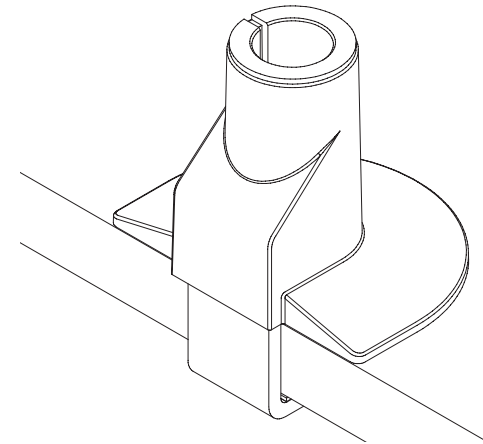
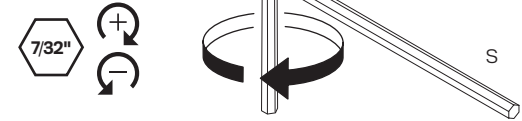

**i** If the monitor arm or pole does not easily fit into the mount, remove the bushing from the mount and place it on the monitor arm or pole and press firmly back into the mount.

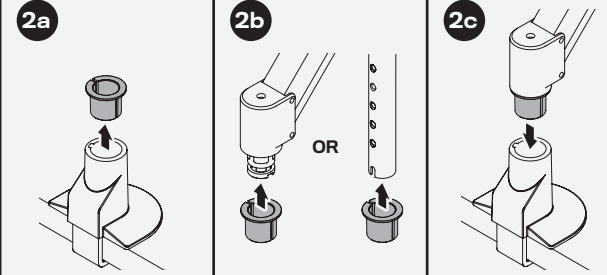

# THRU-DESK CONFIGURATION\*

3

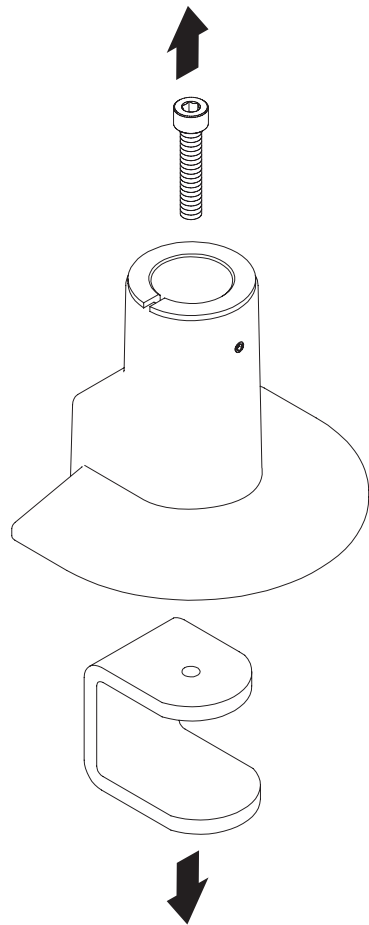

4

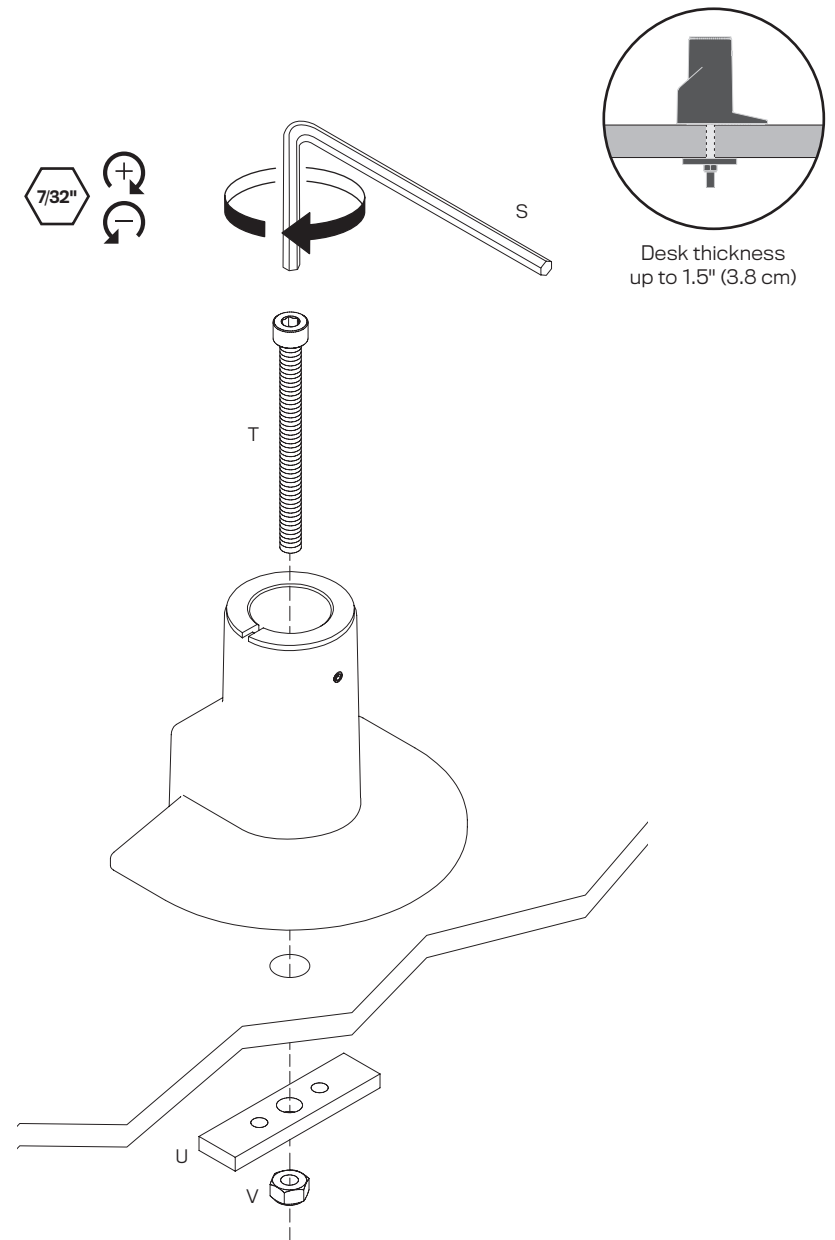

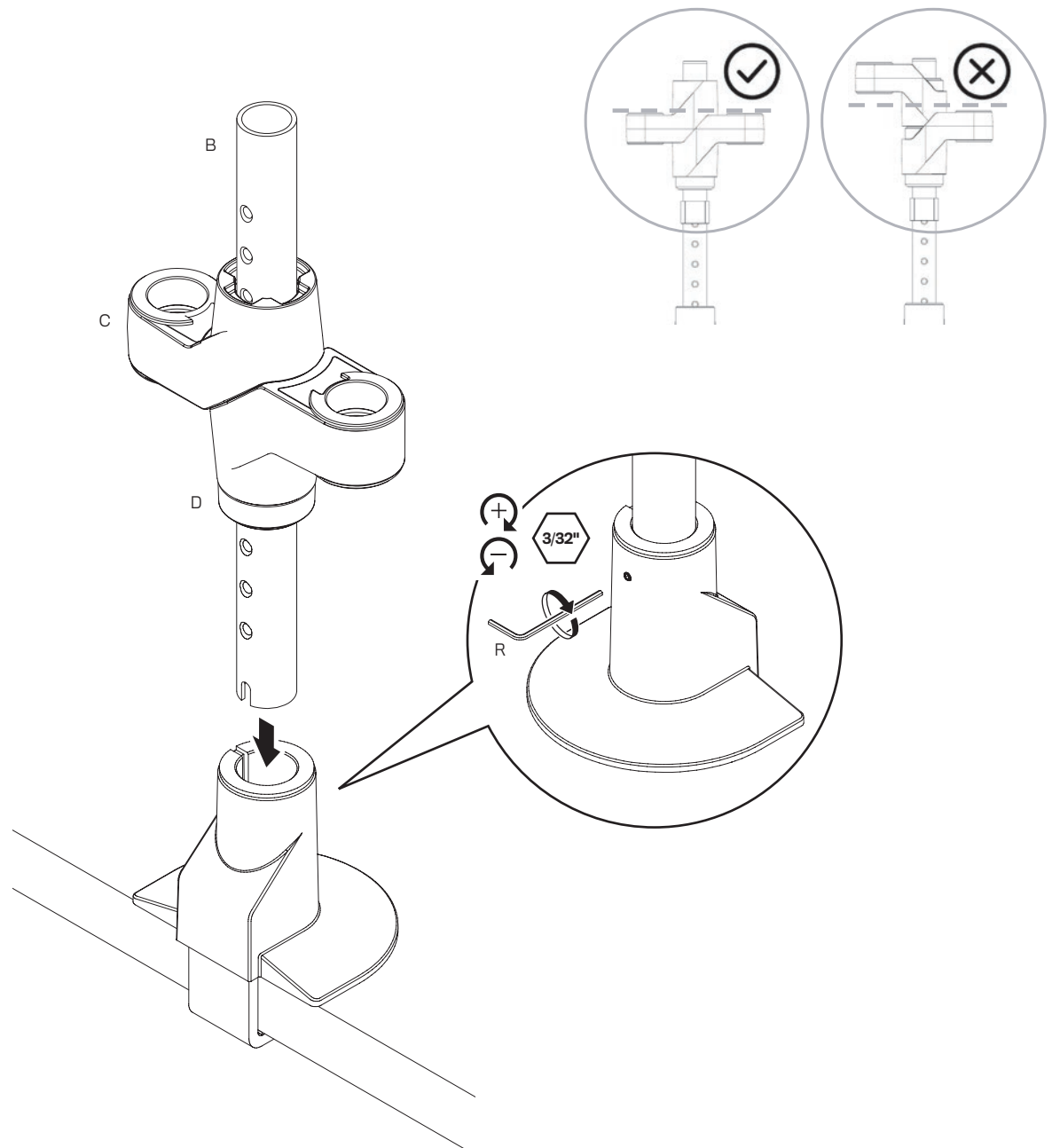
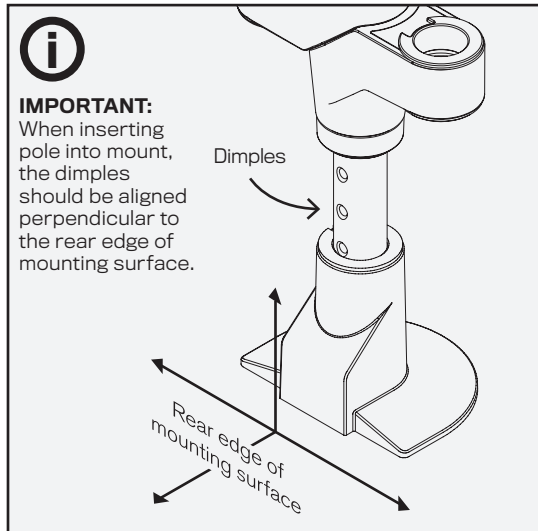

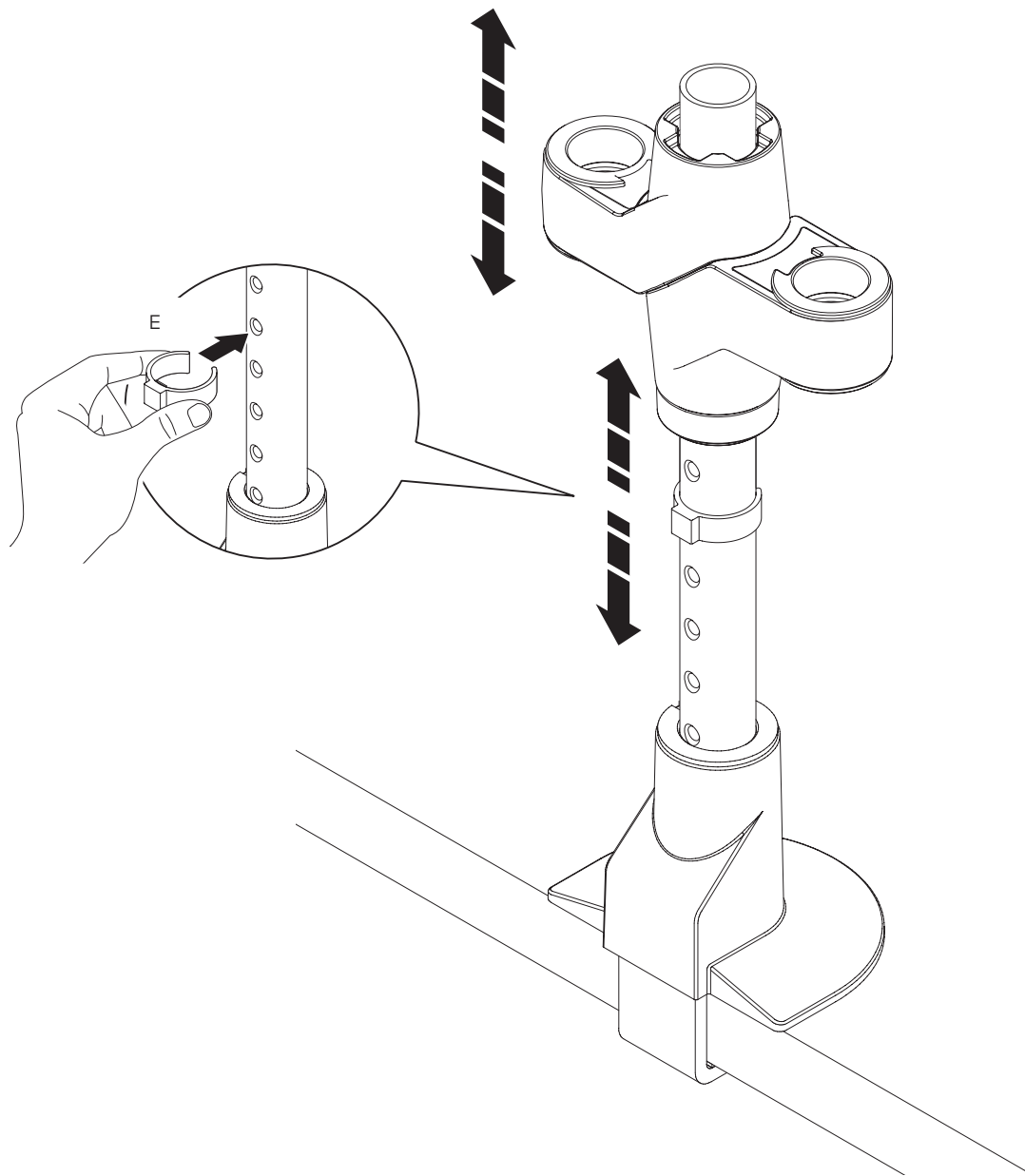



7

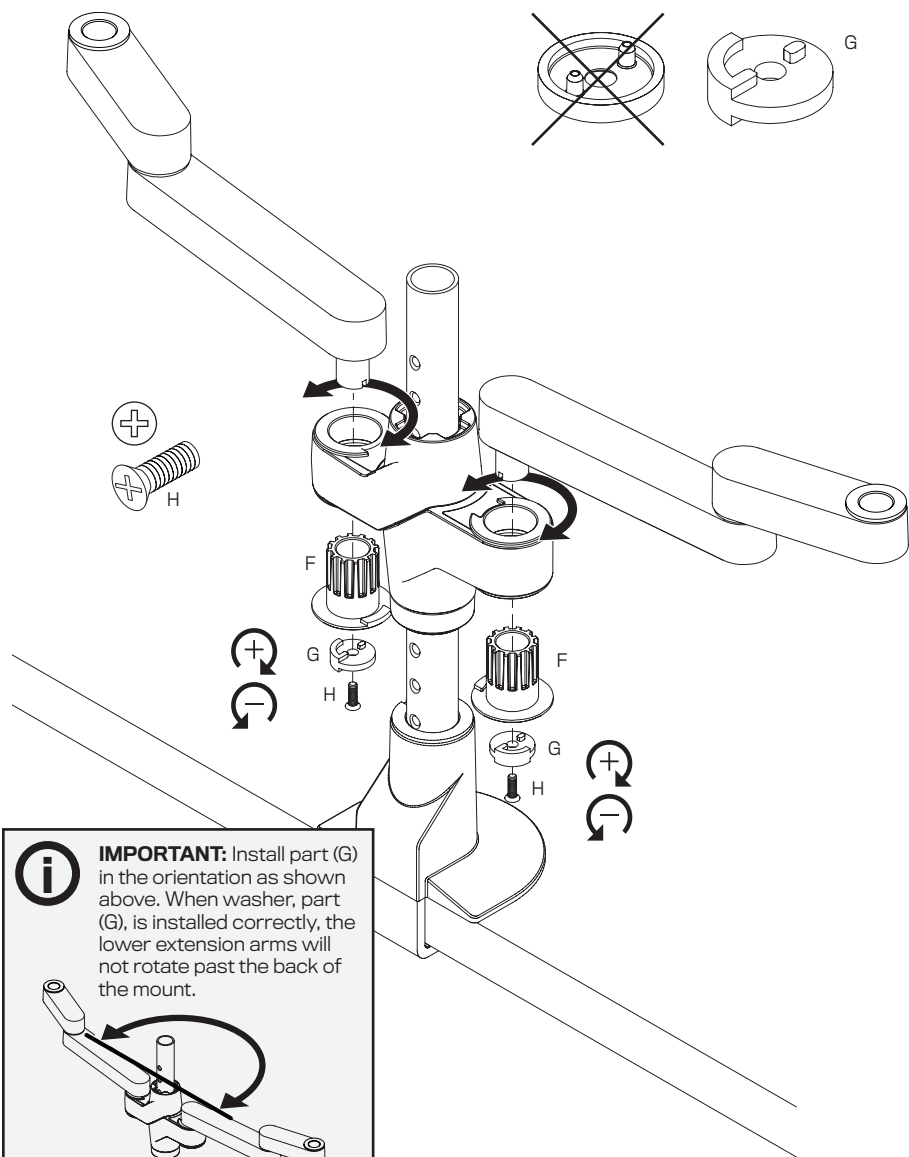

8

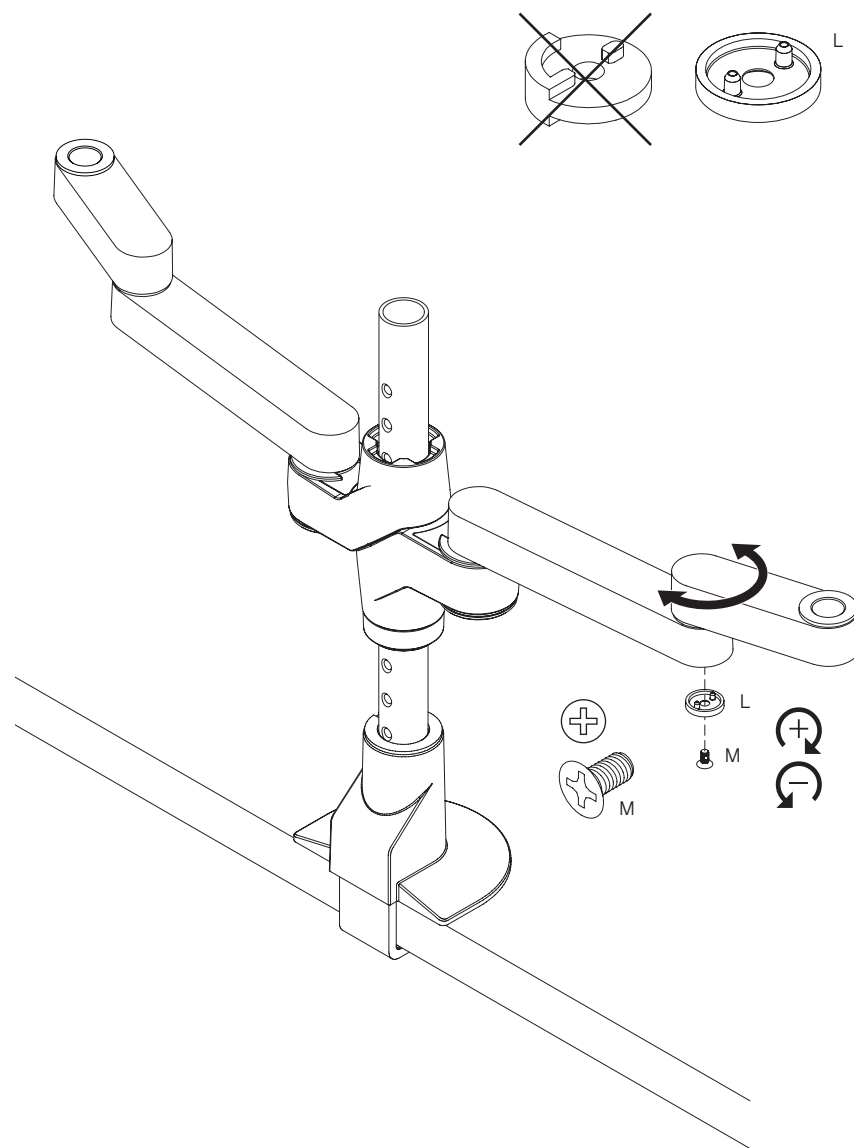

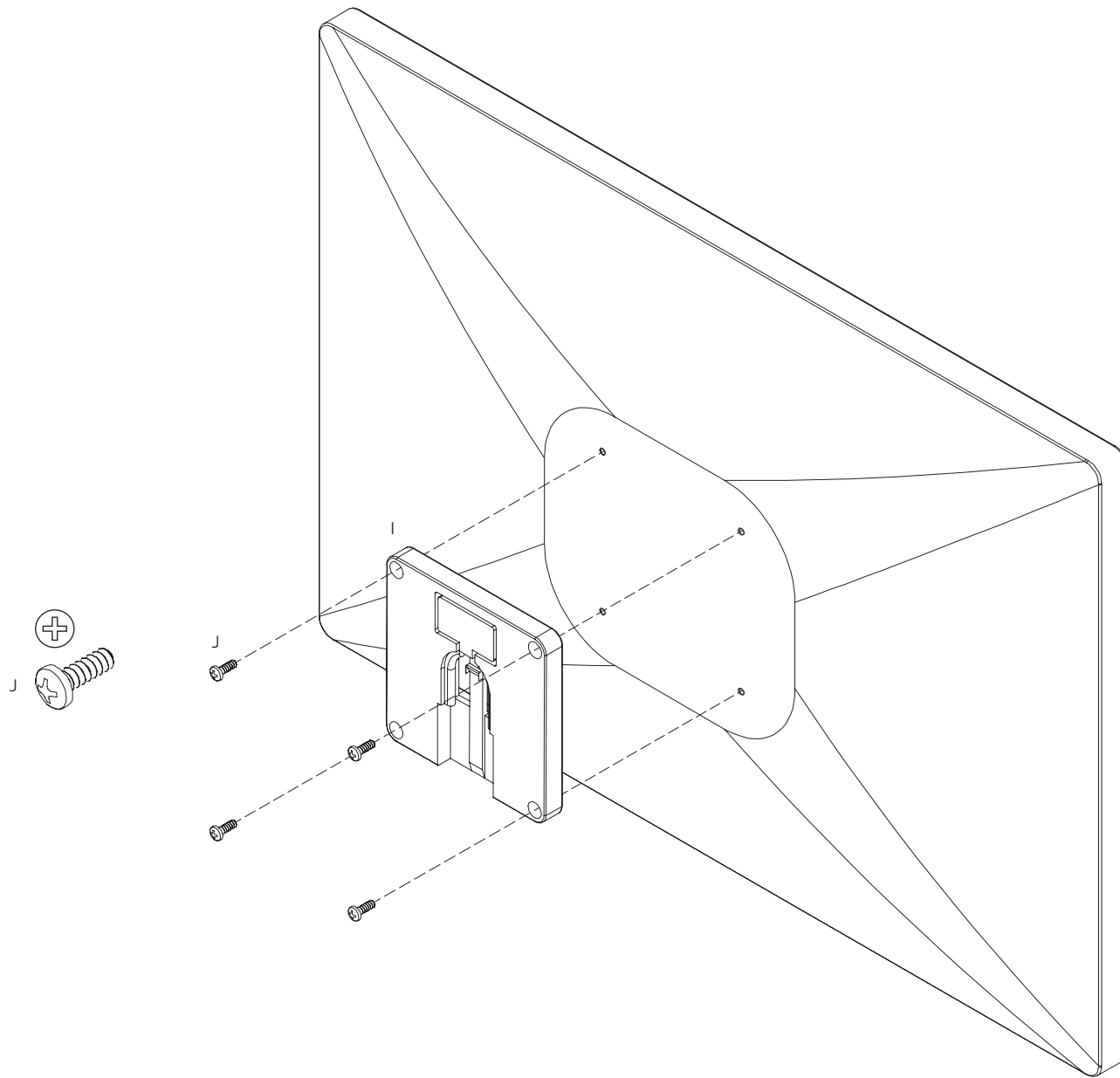

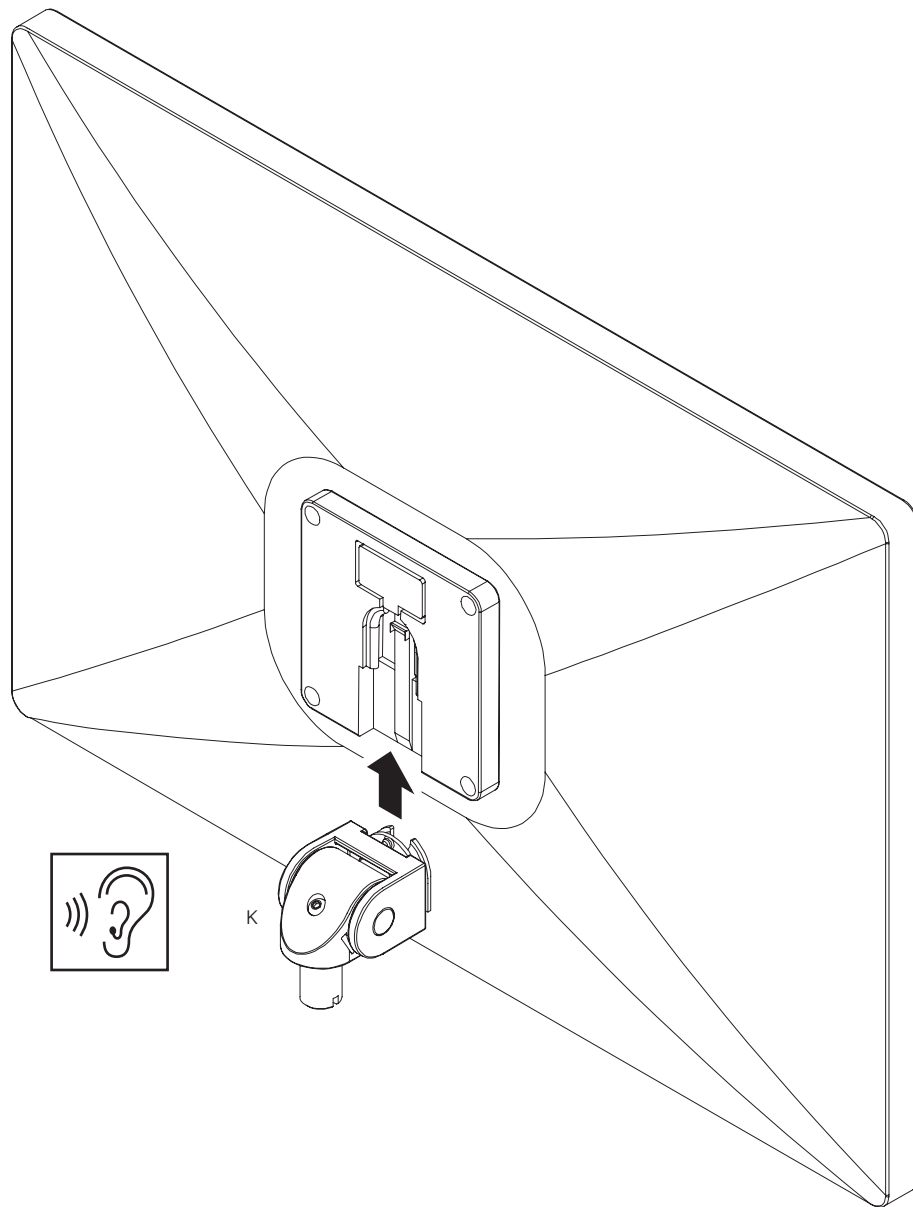

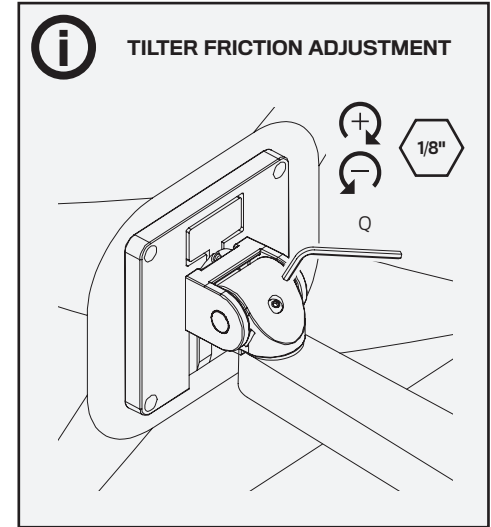
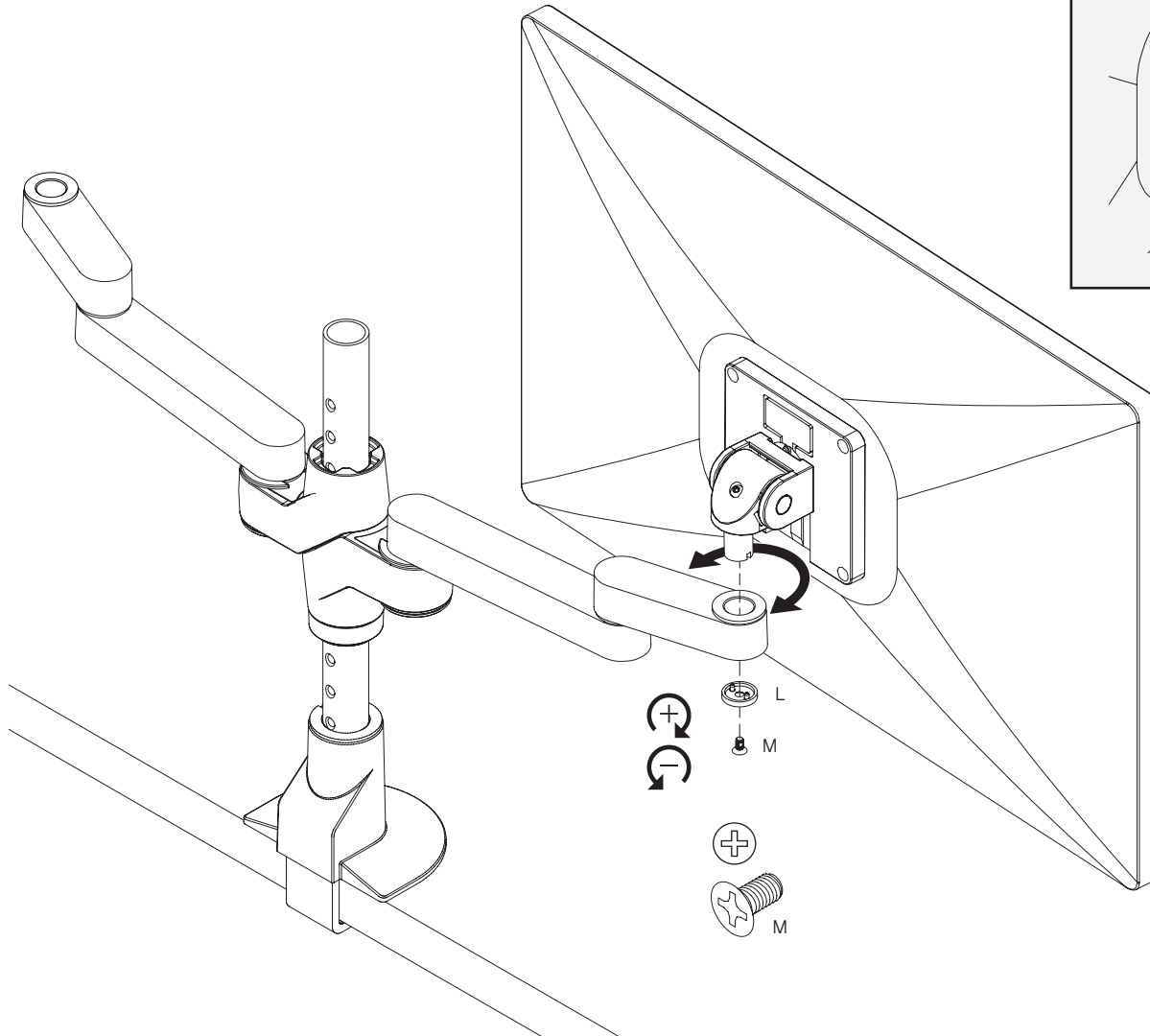
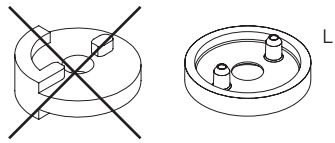

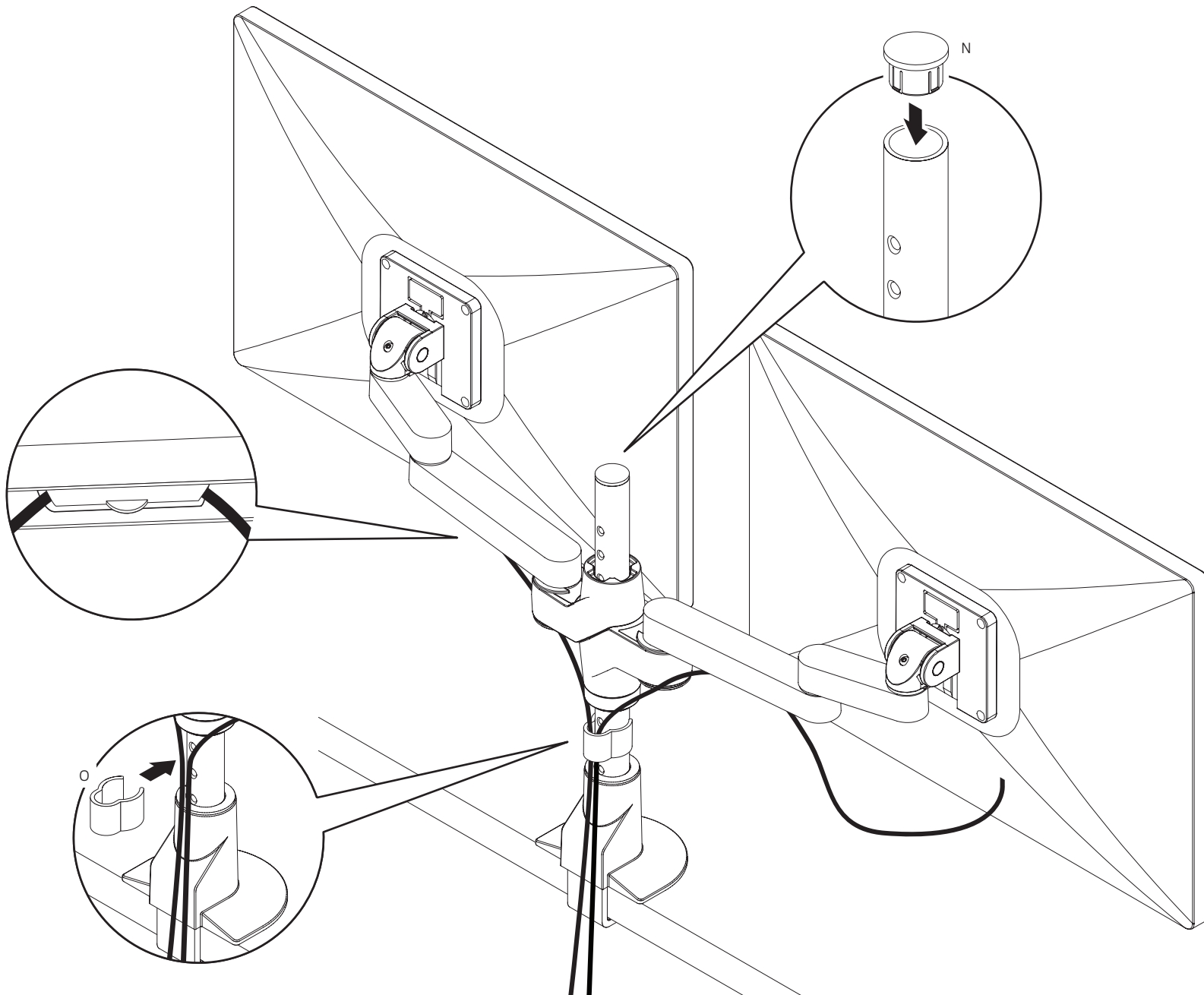

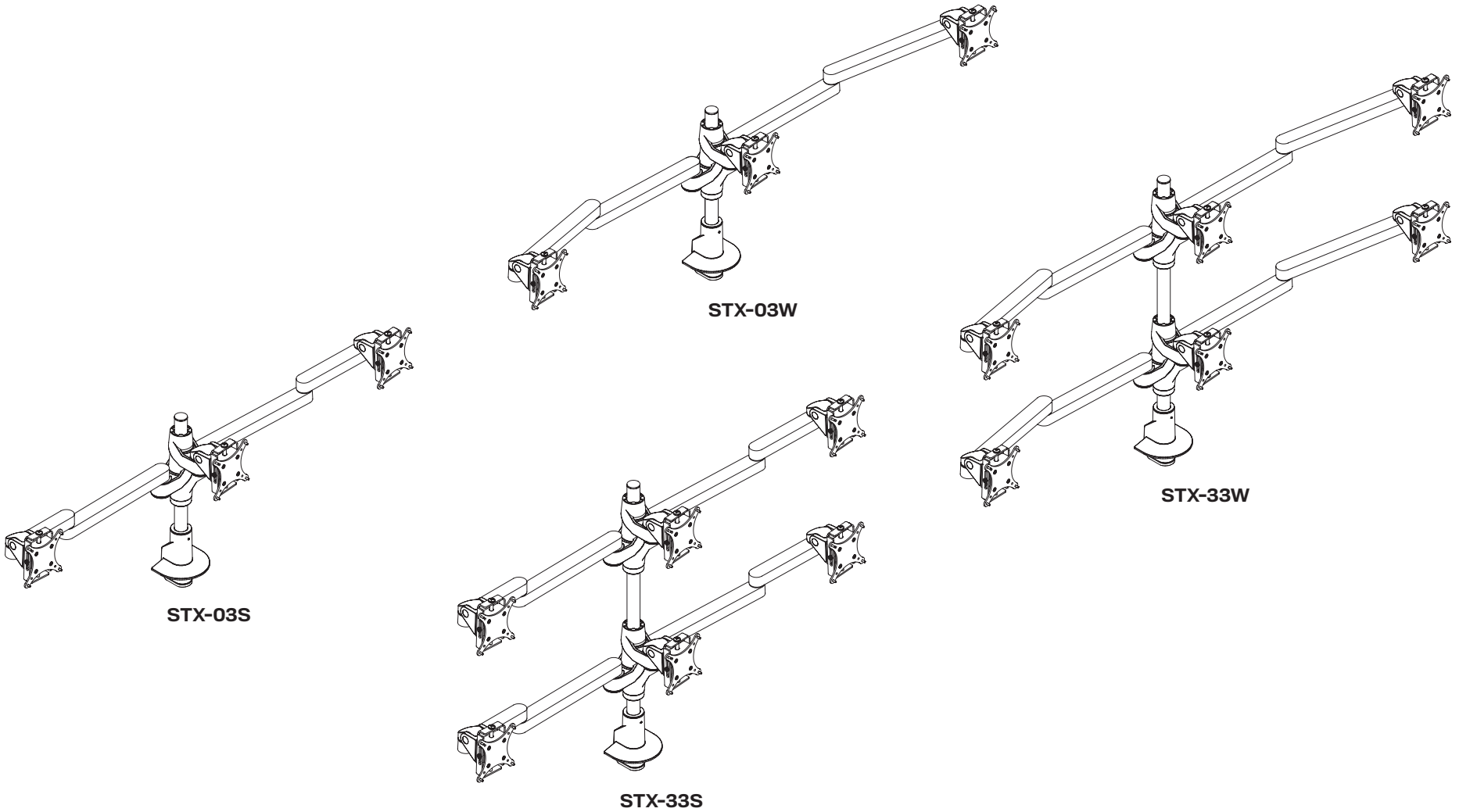



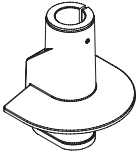
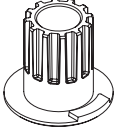
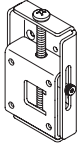

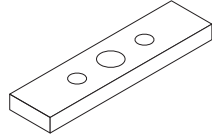

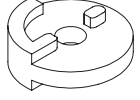
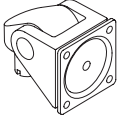
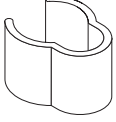





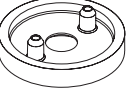
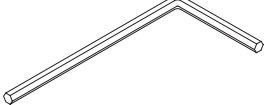
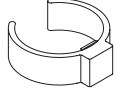
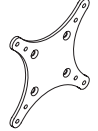

# PARTS LIST

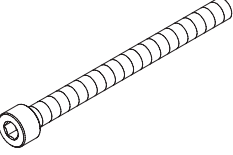
<p>A Top Down Mount 8524</p> 	<p>F Bushing Adapter 112945</p> 	<p>K Height Adjust Adapter 8473</p> 	<p>P Pole Cap 105195</p> 	<p>U* Spacer 701544</p> 
<p>B Dimpled Pole 110607-14</p> 	<p>G Rotation Stop for Extension Arms 113703</p> 	<p>L Monitor Tilter 405397</p> 	<p>Q Cable Clip 104533</p> 	<p>V* Lock Nut 710015</p> 
<p>C Stackable Mount 413054</p> 	<p>H 10-32 x 5/8" Phillips Pan Head Screw 702200</p> 	<p>M M4 x 12mm PhPHS (4-pack) 702096</p> 	<p>R 3/32" Allen Wrench 700146</p> 	
<p>D Pole Collar 113332</p> 	<p>I 10-32 x 3/8" PhPHS (4-pack) 702281</p> 	<p>N Dog Washer 105189</p> 	<p>S 7/32" Allen Wrench 701127</p> 	
<p>E Pole Clip 113449</p> 	<p>J 75/100mm VESA Adapter 105587</p> 	<p>O 10-32 x 3/8" FPHMS w/Lock Patch 705198</p> 	<p>T* M8 x 95mm SCHS 716061</p> 	

# DESK CLAMP CONFIGURATION

1

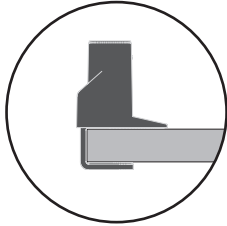

Desk thickness  
up to 1.5" (3.8 cm)

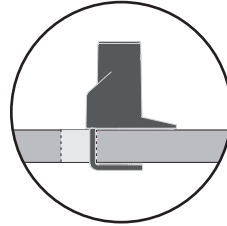

Desk thickness  
up to 1.5" (3.8 cm)

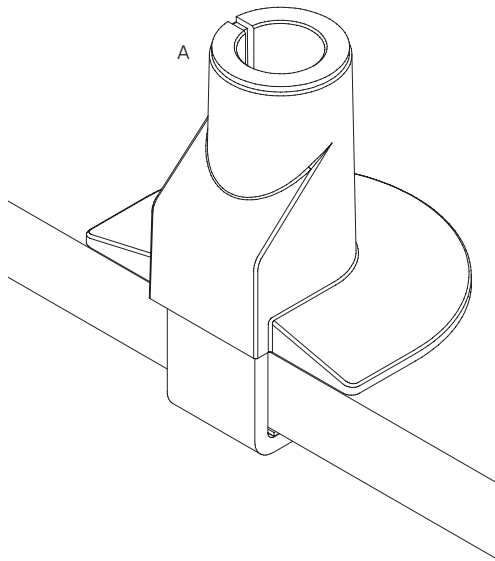

OR

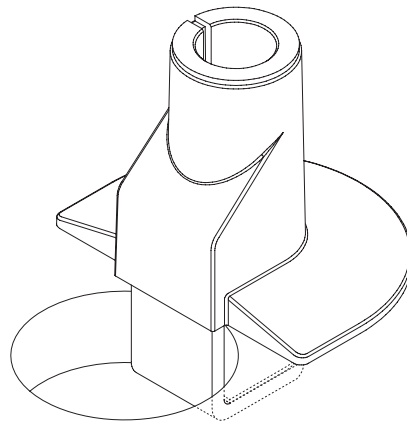

2

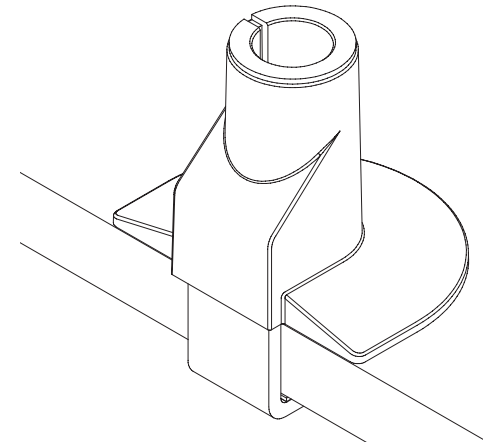
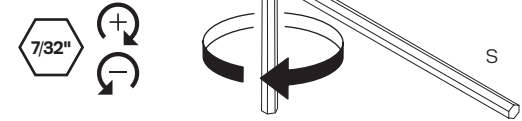

**i** If the monitor arm or pole does not easily fit into the mount, remove the bushing from the mount and place it on the monitor arm or pole and press firmly back into the mount.

2a

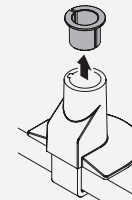

2b

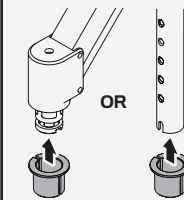

2c

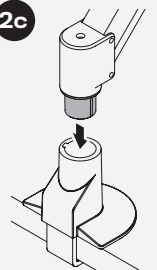



THRU-DESK CONFIGURATION\*

3

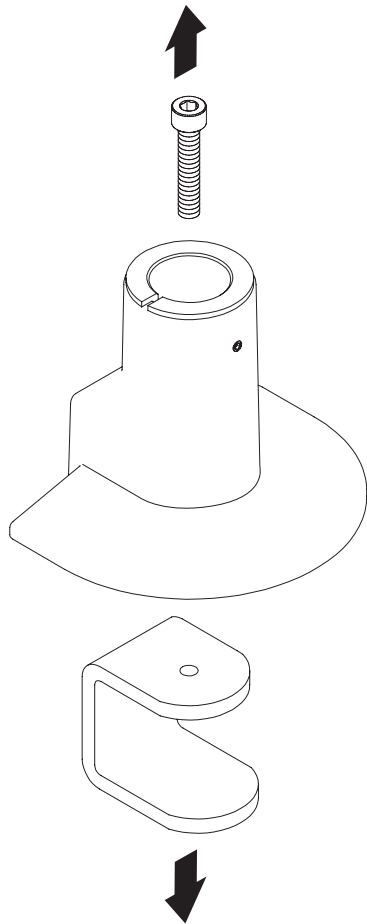

4

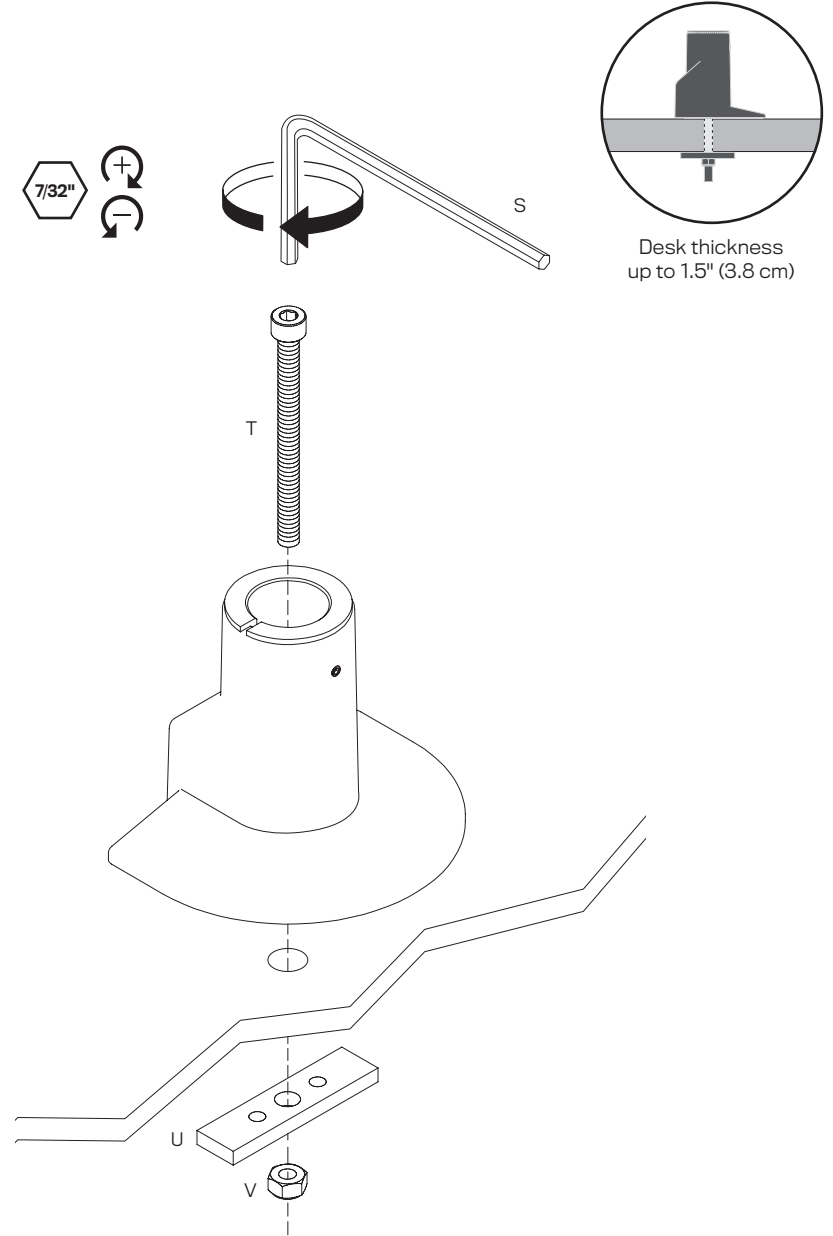



**IMPORTANT:**  
When inserting pole into mount, the dimples should be aligned perpendicular to the rear edge of mounting surface.

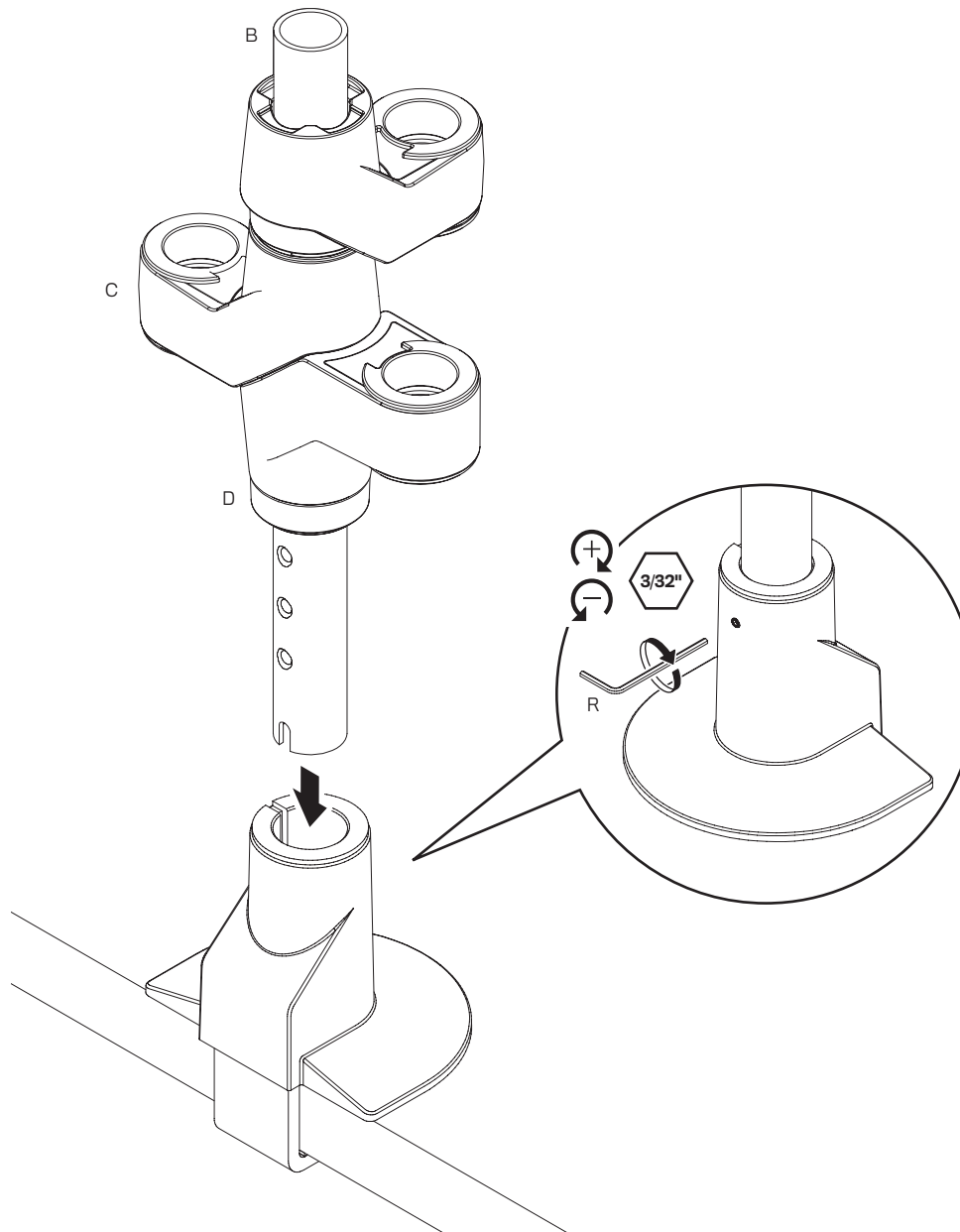
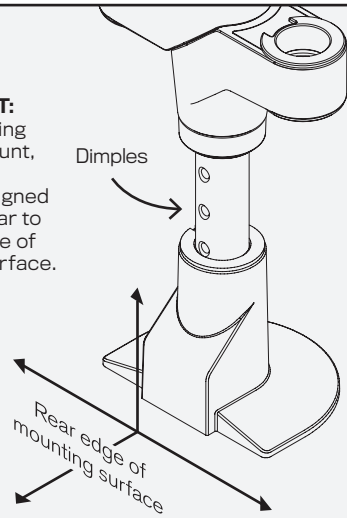

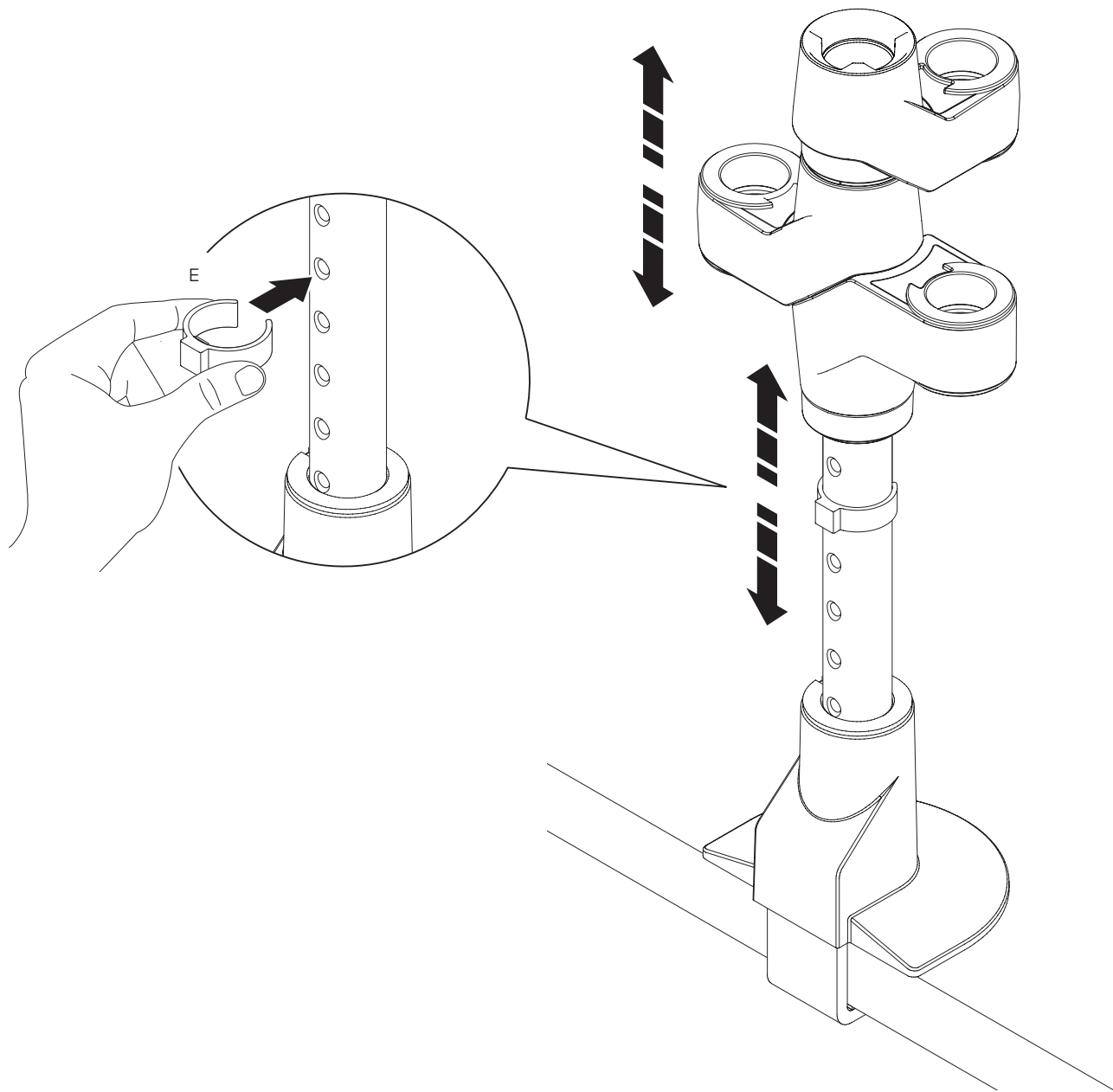

7

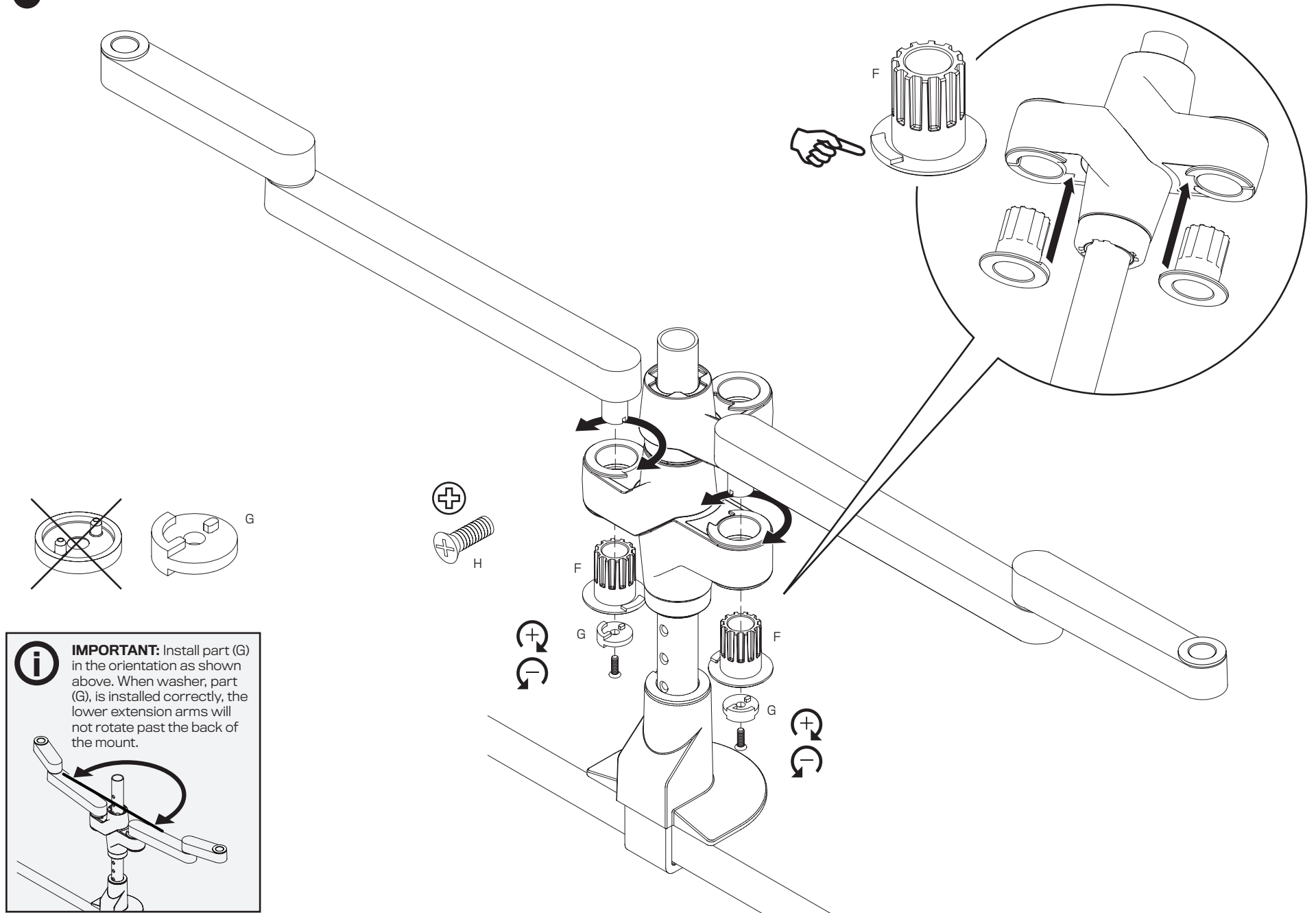

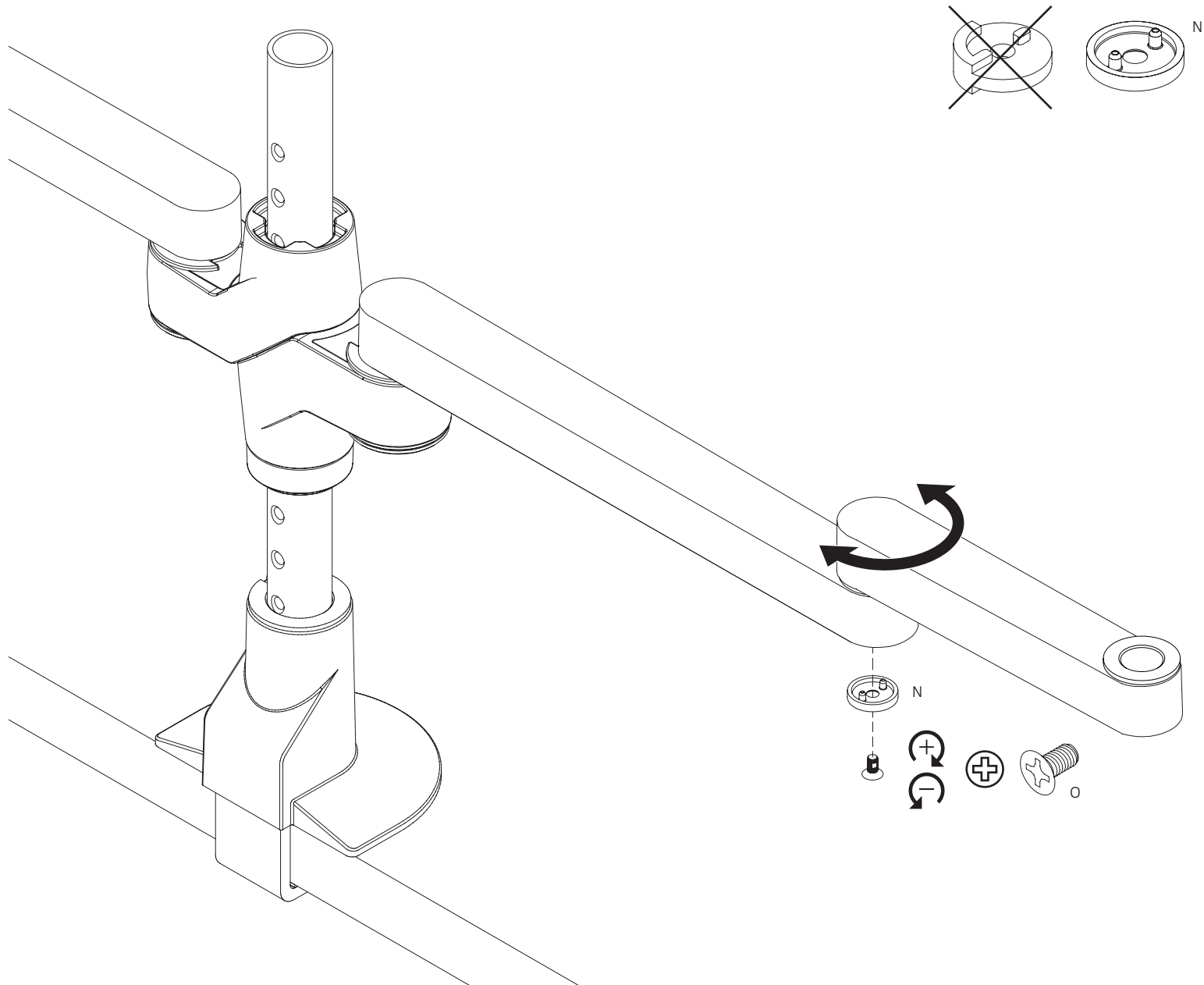

9

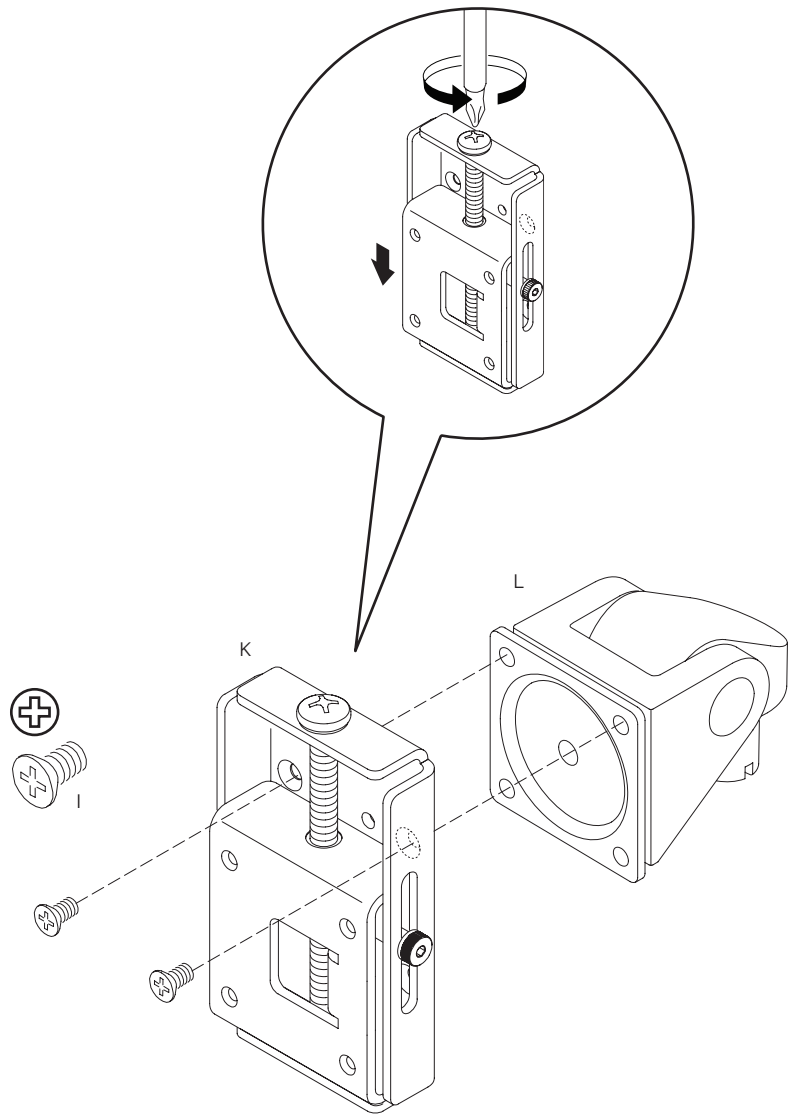

10

