

# **JBC**

[www.jbctools.com](http://www.jbctools.com)

## **INSTRUCTION MANUAL**



## **Guide sets for AL250-B**

# Packing List

The following items should be included:

**Guide set** ..... 1 unit

Ref. 0002399 - **Ø 0,4 - 0,5 mm** (0.015 - 0.02 in)

Ref. 0002402 - **Ø 0,6 - 0,8 mm** (0.023 - 0.03 in)

Ref. 0002401 - **Ø 0,9 - 1 mm** (0.035 - 0.04 in)

Ref. 0002843 - **Ø 1,1 - 1,5 mm** (0.043 - 0.06 in)

Ref. 0013915 - **Ø 1,6 - 1,8 mm** (0.062 - 0.07 in)

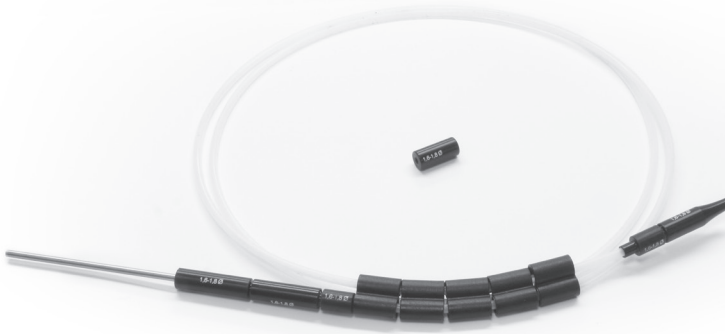

**Driver Gear** ..... 1 unit  
Ref. 0002863



**Manual** ..... 1 unit  
Ref. 0004111

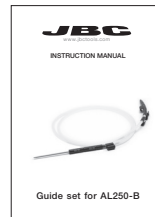

*\*Only included in the Ø 1,1 - 1,5 mm & Ø 1,6 - 1,8 mm for a correct dragging of the solder wire.*

## Guide set assembly

1. Open dragging mechanism.
2. Place the guide set and tighten the screws.

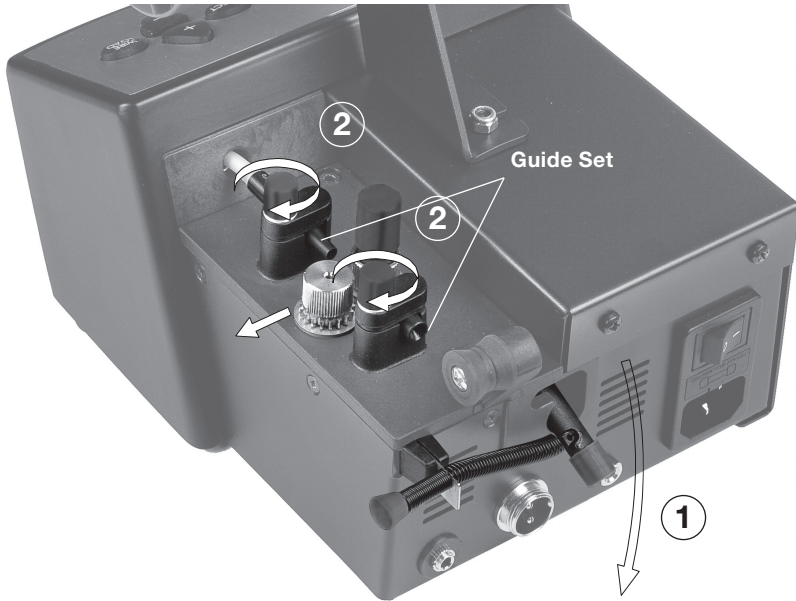

3. Insert the guide set in the tool. You must leave a gap of 8-10 mm between cartridge tip and the end of the guide tube.

4. Tighten the guide tube screw to block the position of the guide.

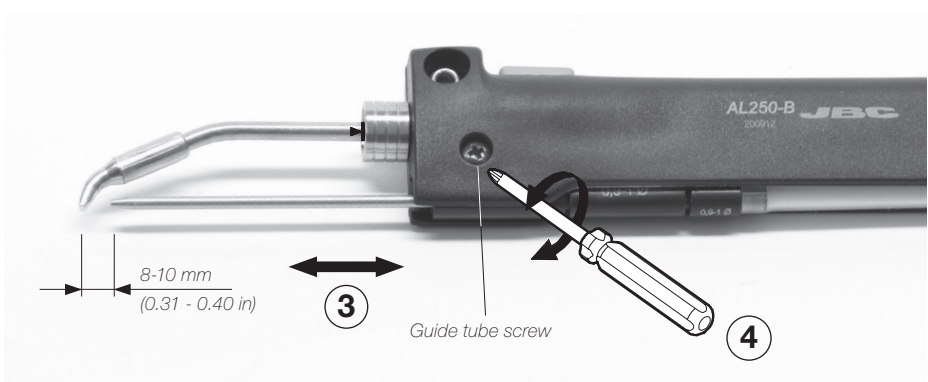

5. Take the solder wire from the reel until the guide tube start.

6. Close the dragging mechanism.

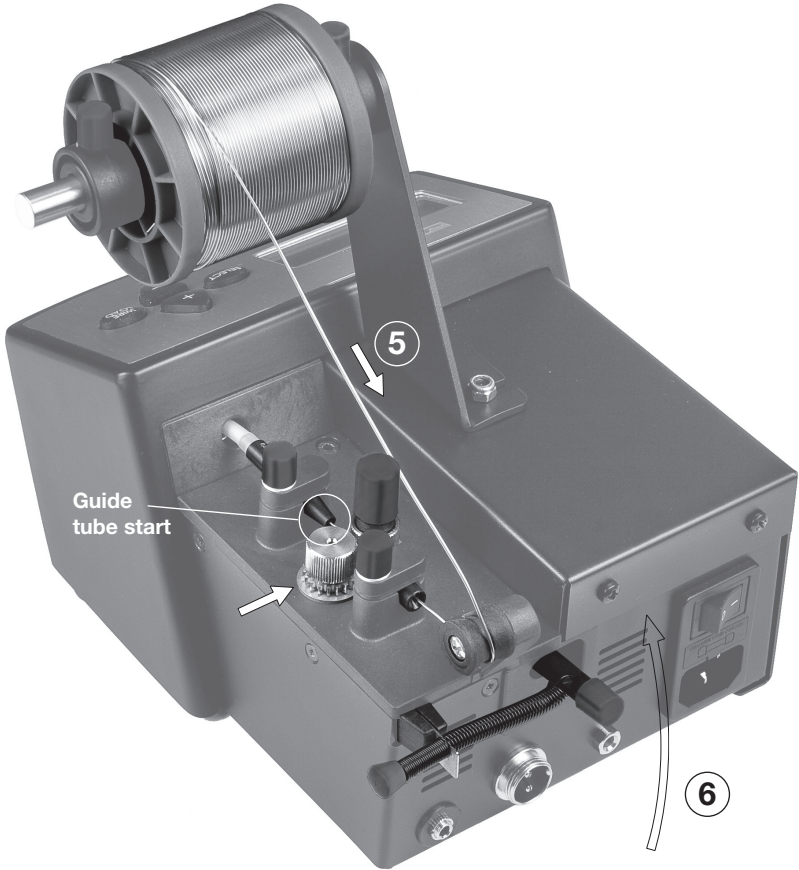

7. Connect the Auto-feed Iron to the station and switch it on. With the Iron out of the

stand, press the WIRE LOAD key till the solder leaves by the end of the guide tube.

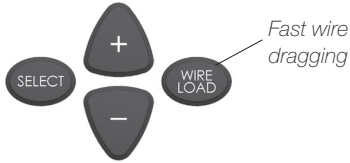

**LOADING  
SOLDER WIRE**

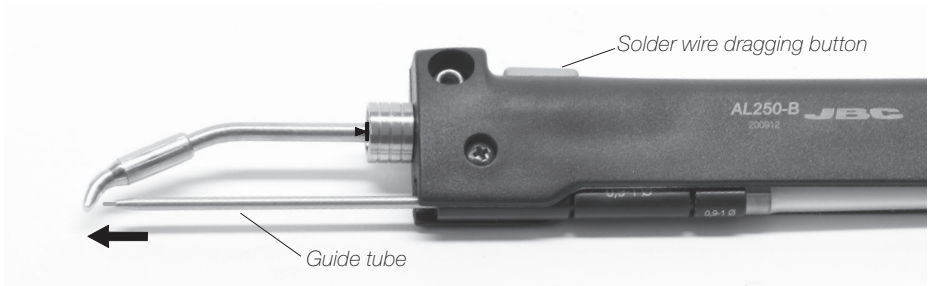

## Clutch regulation

**A.** Adjust the dragging strength to allow the forwarding of the solder wire and to avoid stall and or clogging situations when any cause arises.

**B.** Tighten the dragging mechanism.

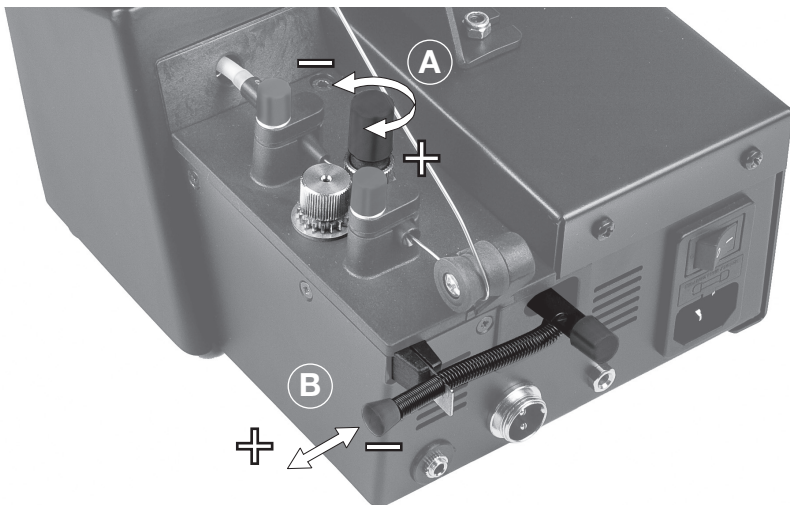

## Driver gear replacement

When using solder wire within  $\varnothing$  1,1 to  $\varnothing$  1,8 mm you must use the Drive gear (Ref. 0002863) for dragging system. This gear must replace the one that is supplied with the station. To do that follow the next instructions:

1. Open the dragging mechanism.

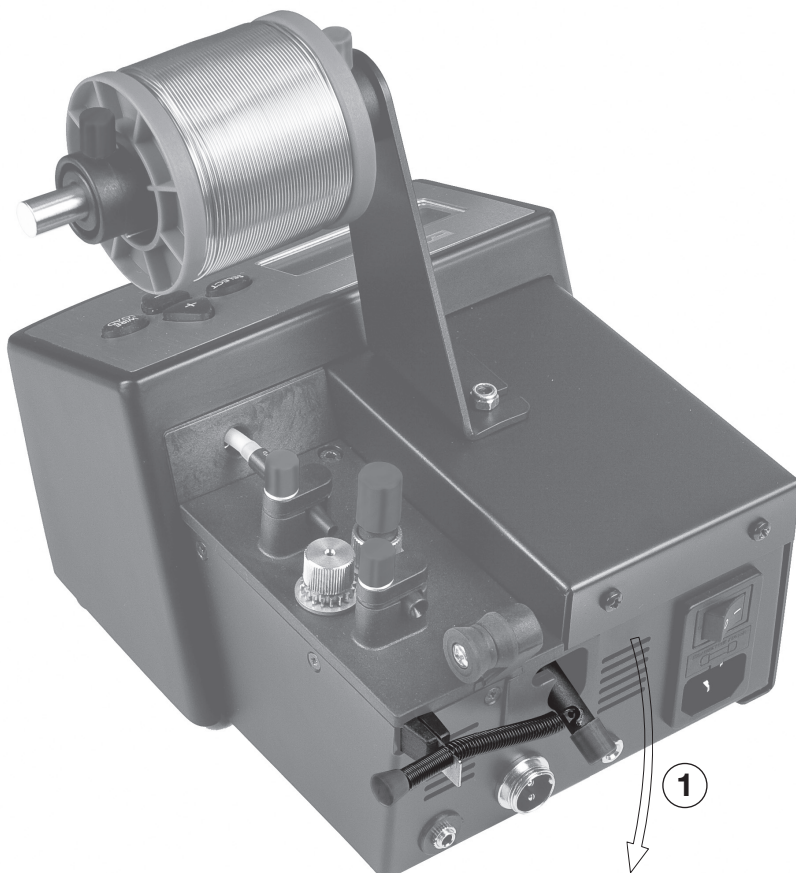

**2.** Unscrew the clutch regulation assembly and pull it out.

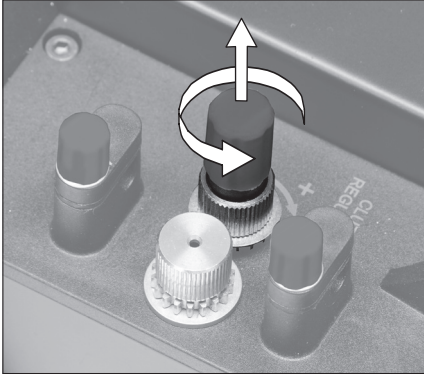

**3.** Pull out the standard driver gear supplied with the station.



**4.** Place the new Driver gear (Ref. 0002863) supplied with the guide set.



**5.** Place the regulation assembly and screw it. Close the dragging mechanism.



# JBC

---

## Warranty

JBC's two-year warranty covers this equipment against all manufacturing defects, including the replacement of defective parts and labour. Warranty does not cover product wear or misuse. In order for the warranty to be valid, equipment must be returned, postage paid, to the dealer where it was purchased.

**Register your warranty within 30 days of purchase in [www.jbctools.com/productregistration](http://www.jbctools.com/productregistration)**

---



This product should not be thrown in the garbage.

In accordance with the European directive 2002/96/EC, electronic equipment at the end of their life must be collected and returned to an authorized recycling facility.



Manual in other languages available on our website

**[www.jbctools.com](http://www.jbctools.com)**