

# **JBC**

[www.jbctools.com](http://www.jbctools.com)

## **INSTRUCTION MANUAL**

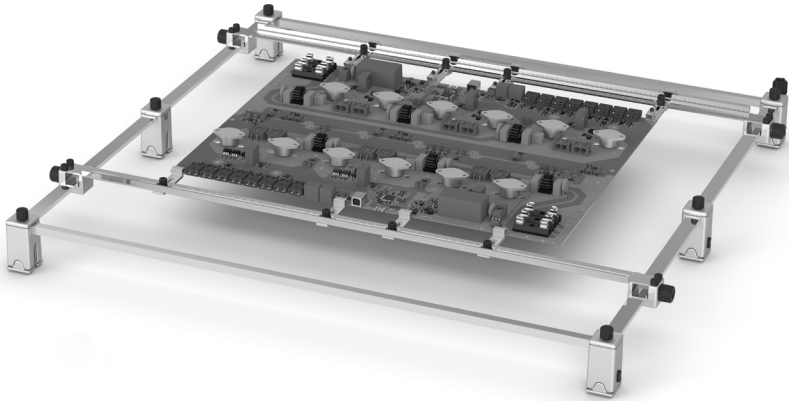

# **PSX**

XL PCB Support

This manual corresponds to the following reference:

**PHXL-SA**

## Packing List

The following items are included:



**XL PCB Support** ..... 1 unit



**Allen Key** ..... 1 unit  
Ref. 0013754



**Manual** ..... 1 unit  
Ref. 0026996

## Features

Adjustable Slot Clamps  
for PCB fixation.

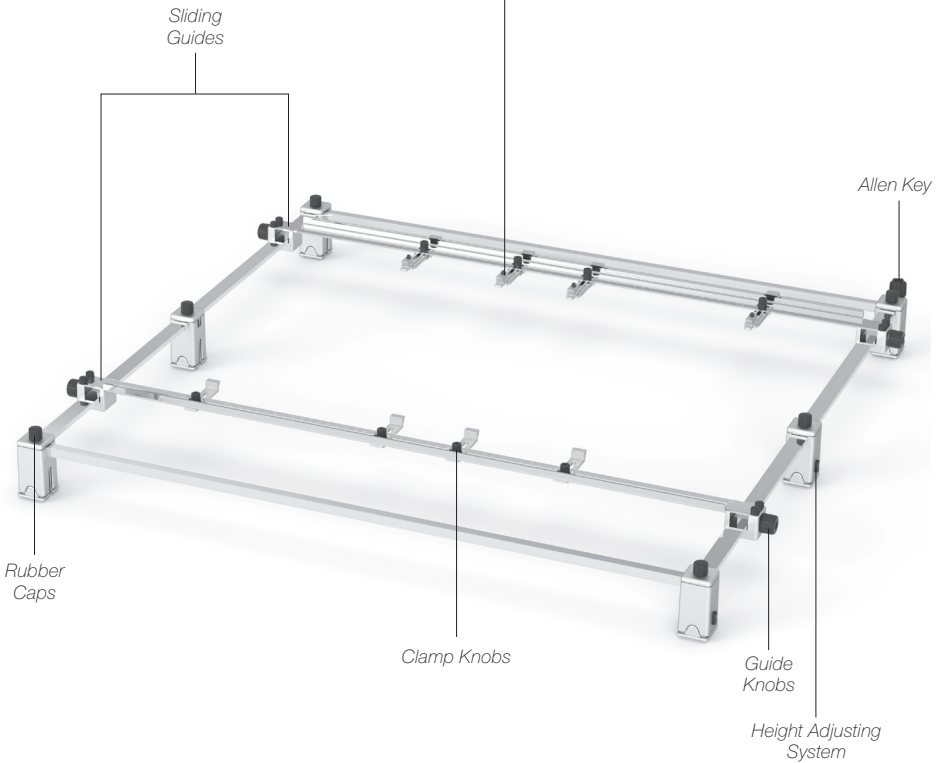
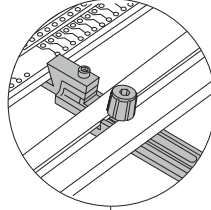

# Height Adjustment

PSX Support allows to change the height between the PCB and the preheater heating area. It can be chosen between **3 positions** for working height adjustment. To change the height, do as follows:

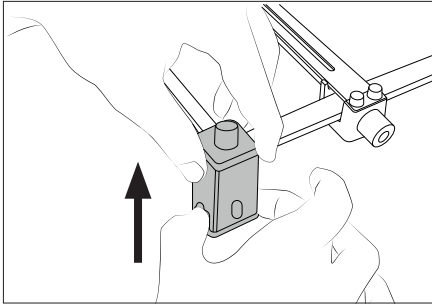

To raise the support, hold the base and pull up.

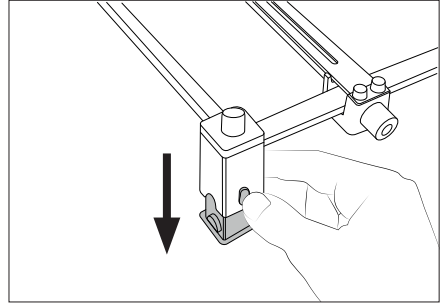

To lower the support, press the button and move down.

It is also possible to use JBC's metallic supports to stabilize the PCB so as to avoid PCB deformation. Depending on the working height, Ref. PH201\*, PH202\* or PH203\* can be used. Arrange them between the PCB and the Preheater as shown below.

**Low level**  
28 mm

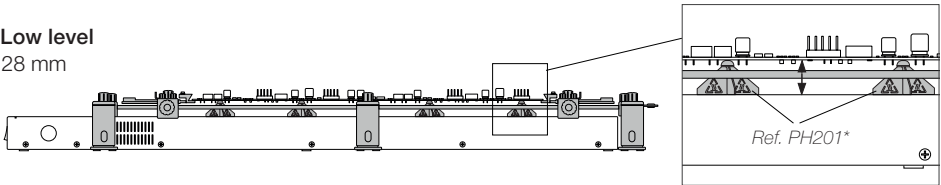

**Medium level**  
38 mm

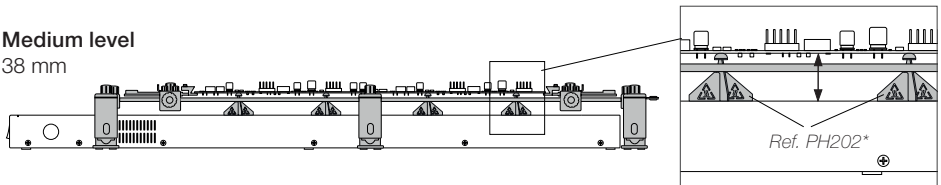

**High level**  
48 mm

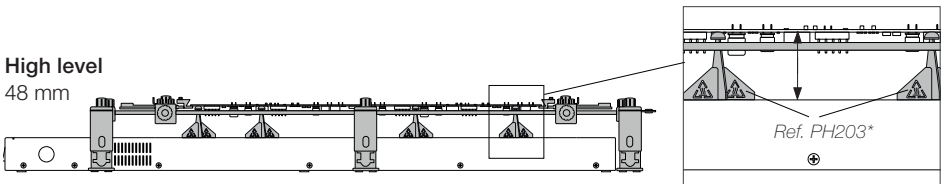

*\* not included, sold separately*

## Fast PCB Replacement

XL PCB Support lets you replace PCBs of the same batch fast and easily. Use the sliding guides to change the PCBs.

### Removing the PCB

Loosen one sliding guide, pull back and lift out the PCB.

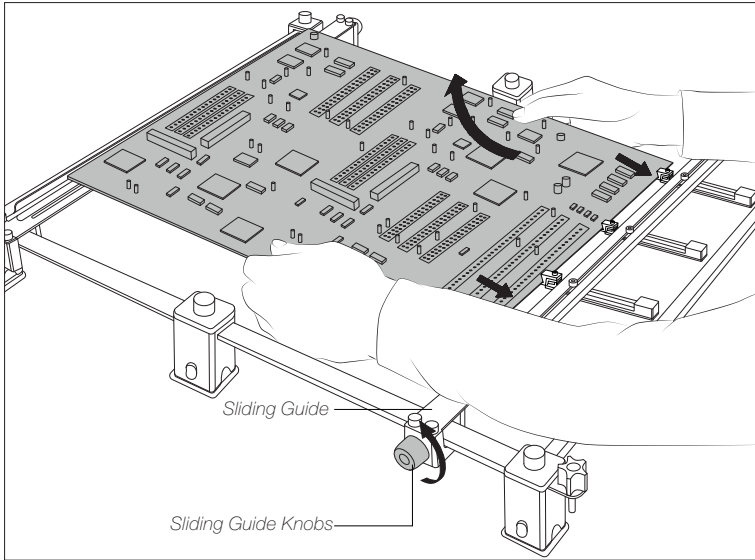

### Placing another PCB

Position it and tighten the sliding guide knobs.

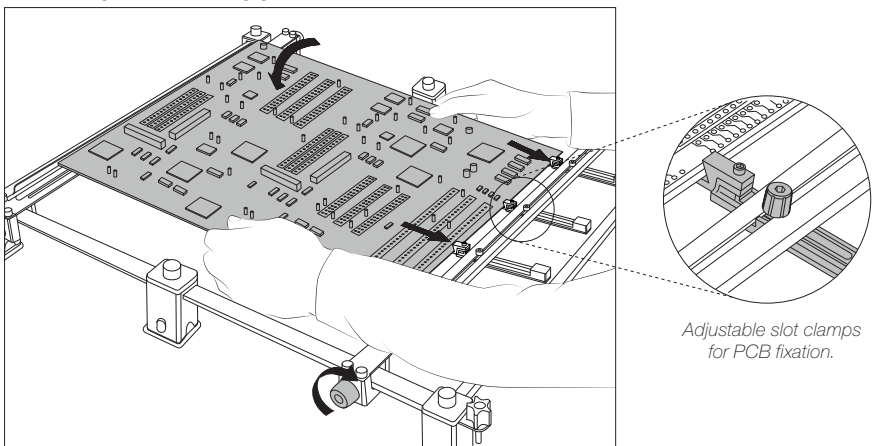

## Maintenance

Before carrying out maintenance or storage, always allow the support to cool down.

- Check periodically that the Support is clean, especially the lateral guides.
- Use a damp cloth when cleaning. Alcohol can only be used to clean the metal parts
- Replace any defective or damaged piece. Use original JBC spare parts only.
- Repairs should only be performed by a JBC authorized technical service.

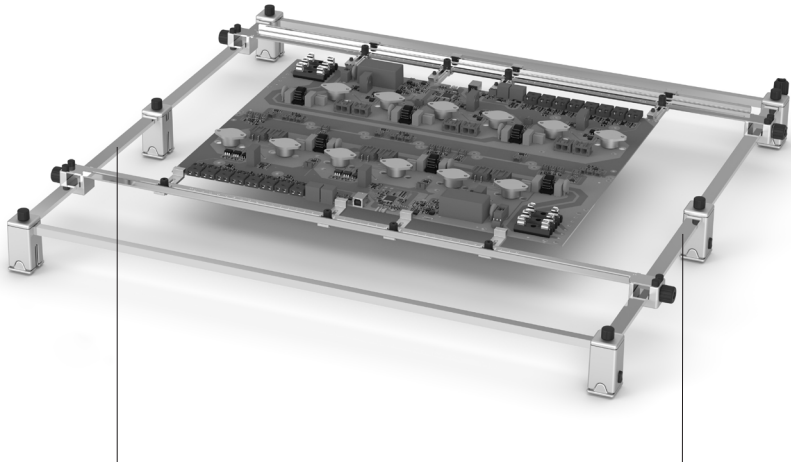

*Lateral Guides*

## Safety



**It is imperative to follow safety guidelines to prevent electric shock, injury, fire or explosion.**

- The temperature of accessible surfaces may remain high after the unit is turned off. Handle with care.
- Be careful with the remains of liquid tin. In contact with skin, it can cause burns.
- Avoid flux coming into contact with skin or eyes to prevent irritation.
- Be careful with the smoke produced when soldering.
- Keep your workplace clean and tidy. Wear appropriate protection glasses and gloves when working to avoid personal harm.
- This appliance can be used by children over the age of eight as well as persons with reduced physical, sensory or mental capabilities or lacking experience provided that they have been given adequate supervision or instruction concerning use of the appliance and understand the hazards involved. Children must not play with the appliance.
- Maintenance must not be carried out by children unless supervised.

# Specifications

## PSX

### XL PCB Support

Ref.: PHXL-SA

- Total Net Weight: 4.42 kg / 9.74 lb
- Dimensions (Low Position): 75.3 x 73.7 x 7.8 cm  
(L x W x H) 29.65 x 29.02 x 3.07 in
- Dimensions (High Position): 75.3 x 73.7 x 9.8 cm  
(L x W x H) 29.65 x 29.02 x 3.86 in
  
- Total Package Dimensions / Weight: 82 x 80 x 23 cm / 23 kg  
(L x W x H) 32.28 x 31.50 x 9.06 in / 50.71 lb

Complies with CE standards.  
ESD safe.

# JBC

## Warranty

JBC's 2 year warranty covers this equipment against all manufacturing defects, including the replacement of defective parts and labour.

Warranty does not cover product wear or misuse.

In order for the warranty to be valid, equipment must be returned, postage paid, to the dealer where it was purchased.



This product should not be thrown in the garbage.

In accordance with the European directive 2012/19/EU, electronic equipment at the end of its life must be collected and returned to an authorized recycling facility.

