

JBC

www.jbctools.com

INSTRUCTION MANUAL



CSR

Cartridge Stand for Robot

This manual corresponds to the following references:

- **CS2R245-B** for R245 cartridges
- **CS2R470-B** for R470 cartridges

Packing List

Either Ref. CS2R245-B or Ref. CS2R470-B is included:



Cartridge Stand for Robot 1 unit

Upper Center Jig 1 unit

Ref. 0023652 for CS2R245-B

Ref. 0023625 for CS2R470-B



Lower Center Jig 1 unit

Ref. 0023626 for CS2R245-B

Ref. 0023648 for CS2R470-B



Manual 1 unit

Ref. 0027877

Features

CSR is designed to be used in automatic soldering processes. Two pairs of grippers can be used to hold the cartridges while they are not in use.

It can work in combination with JBC Automatic Soldering Irons (**TRA**) and the new cartridges for automation (**R245** and **R470** ranges).



Assembly

CSR needs to be fixed to the robot work place area. Use a **DIN912 M6** screw and the mounting hole as shown below.

The gripper actuators must be connected to an air-circuit by using the tube connections **A** and **B**.

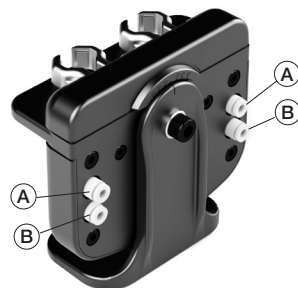

Gripper Actuator	
Fluid	Air
Applicable tubing	Ø 4mm
Operating pressure	1,5 to 7 bar

- (A) Tube connection to fix Cartridge.
- (B) Tube connection to release Cartridge.

Work Position Adjustment

CSR body can be pivoted 35° both sides to suit the inclination of your Soldering Head in every job necessities. Use a 5mm allen key to loosen the bolt and pivot CSR body manually.

Note the angle indicator around the bolt area. Tighten the bolt holding the body in the desired position. The soldering head must be set to the same angle.

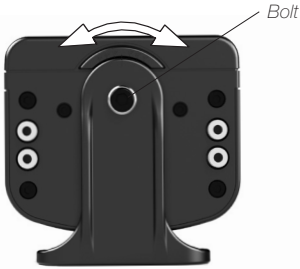

Compatibility

Cartridge Stand	Cartridge Range		Control Unit		Soldering Irons	
	R245	R470	UCR245	UCR470	TRA245	TRA470
CS2R245	●		●		●	
CS2R470		●		●		●

Compatible Cartridges

Find the Cartridge models that best suit your soldering needs on www.jbctools.com

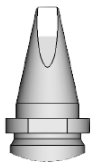

Chisel



Pin / Connector

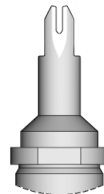

Drag

Tool Position Adjustment

The cartridge plate can be set to four different positions. The flat faces of the plate and the cartridge must match.

Use an 1,5 mm allen key to loosen the three indicated bolts. Evenly pull the plate holder. Remove the cartridge plates.

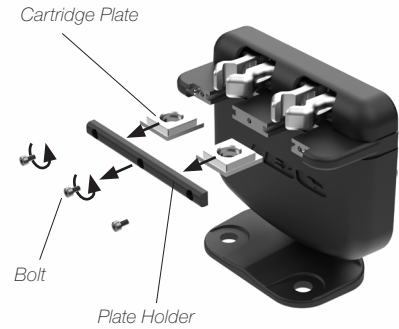
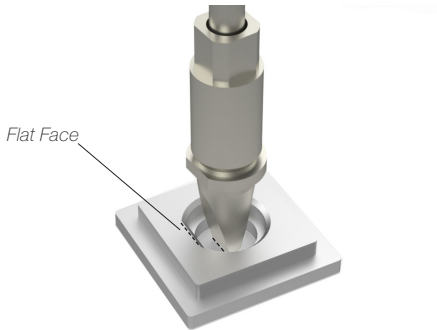

Insert the cartridge plates to any of the four positions you need. The smaller squared shape must face upwards.

Assemble the plate holder to its initial position and tighten the three bolts evenly.

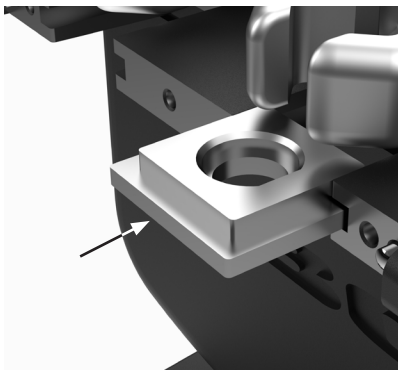

Centering Jig

In order to align CSR to the soldering iron and set the cartridge pick-up points use JBC's centering jig.

Instal both, lower and upper centering jigs, on CSR and the soldering iron as shown.

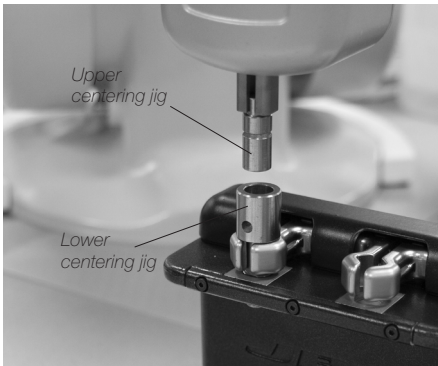

Adjust the soldering iron position until the centering jig is aligned. It must be possible to move in and out smoothly.

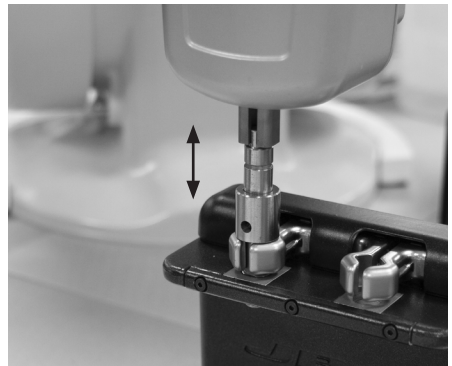

Insert the centering jig completely. Set this point as the pick-up point position. From this point on, the soldering iron should do a linear movement when inserting or removing cartridges.

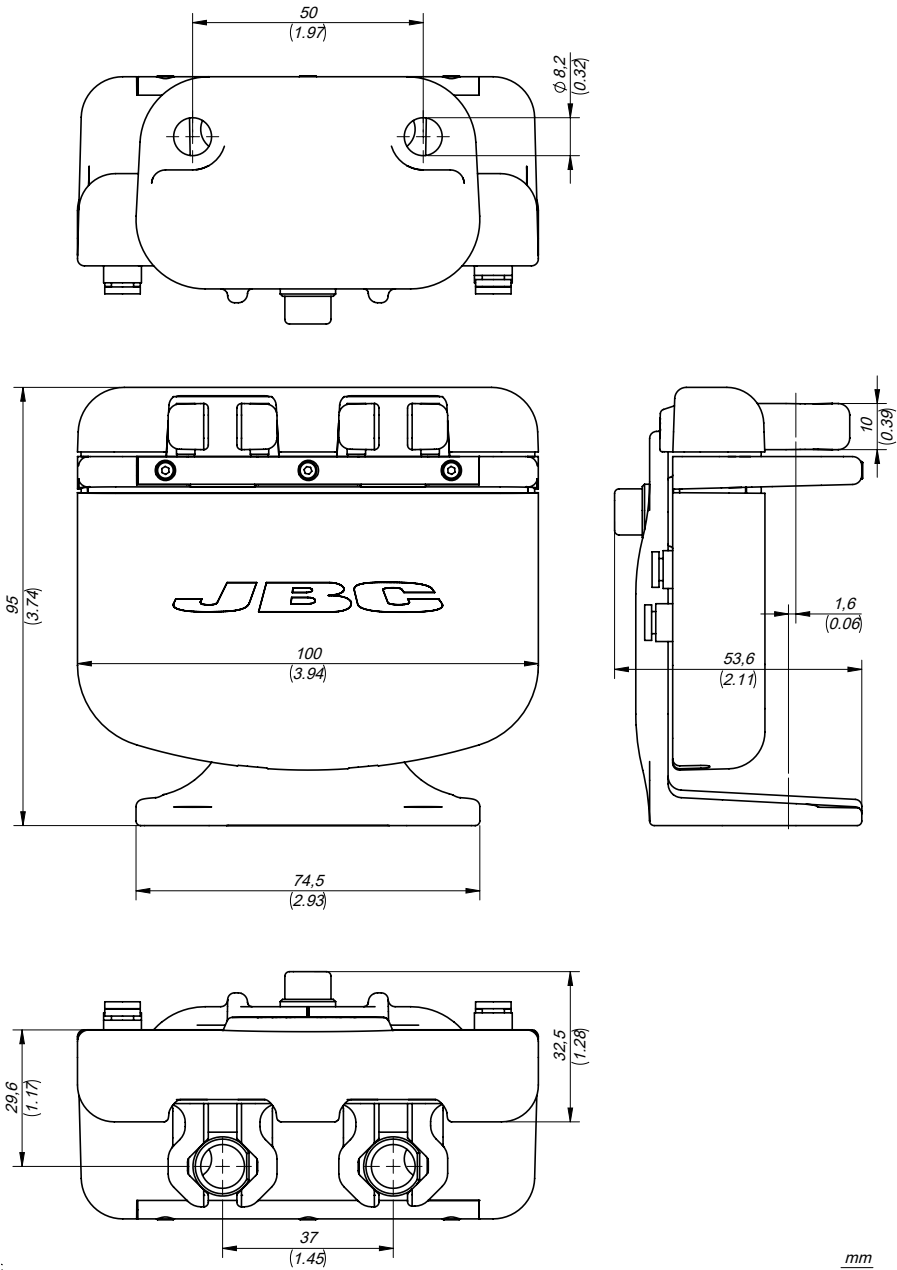

Dimensions

Work Place Example

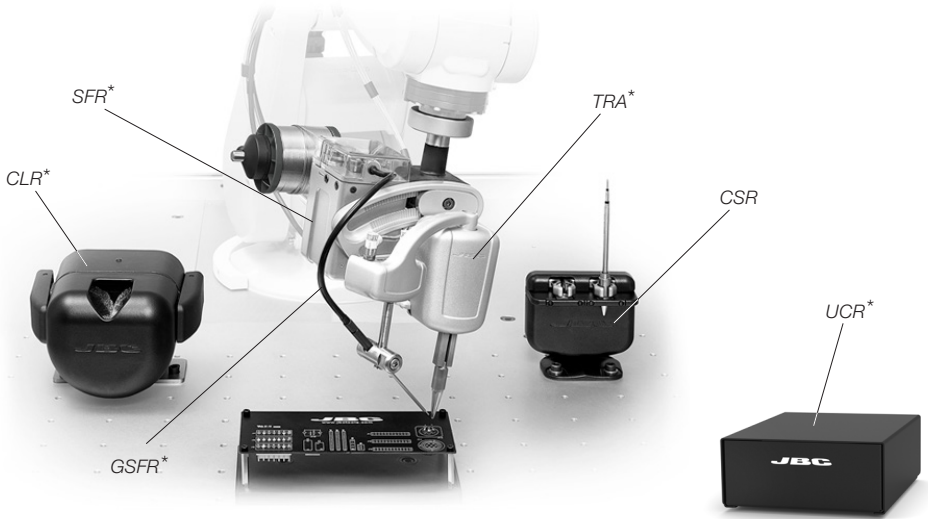

**Not included, sold separately*

Maintenance

- Before carrying out maintenance, always unplug the equipment.
- Use a damp cloth to clean the equipment. Alcohol can only be used to clean the metal parts.
- Periodically check that the metal parts of the equipment are clean.
- Periodically check all cables and tube connections.
- Replace any defective or damaged part. Use original JBC spare parts only.
- Repairs should be performed only by a JBC authorized technical service.
- Under normal operating conditions, the air gripper lifespan is 10 million cycles. It is recommended to replace it at the end of its lifespan.

Safety



It is imperative to follow safety guidelines to prevent electric shock, injury, fire or explosion.

- Do not use the equipment for any other purpose.
- Do not leave the appliance unattended when it is on.
- Be sure that the power supply is disconnected before changing any spare part.
- The temperature of accessible surfaces may remain high after the unit is turned off. Handle with care.
- Heat can cause inflammable products to ignite even when not visible.
- Avoid flux coming into contact with skin or eyes to prevent irritation.
- Be careful with the fumes produced when soldering.
- Keep your workplace clean and tidy. Wear appropriate protection glasses and gloves when working to avoid personal harm.
- Utmost care must be taken with liquid tin waste, which can cause burns.

Specifications

CSR

Cartridge Stand for Robot

Ref.: **CS2R245-B / CS2R470-B**

- Operating pressure 1,5 - 7 bar / 20 - 100 psi

CS2R245-B

- Total Net Weight: 789 g / 1.74 lb
- Package Dimensions/Weight: 221 x 136 x 126 mm / 1004 g
(L x W x H) 8.70 x 5.35 x 4.96 in / 2.21 lb

CS2R470-B

- Total Net Weight: 807 g / 1.78 lb
- Package Dimensions/Weight: 221 x 136 x 126 mm / 1045 g
(L x W x H) 8.70 x 5.35 x 4.96 in / 2.30 lb

Complies with CE standards.
ESD protected.

JBC

Warranty

JBC's 2 year warranty covers this equipment against all manufacturing defects, including the replacement of defective parts and labour.

Warranty does not cover product wear or misuse.

In order for the warranty to be valid, equipment must be returned, postage paid, to the dealer where it was purchased.



This product should not be thrown in the garbage.

In accordance with the European directive 2012/19/EU, electronic equipment at the end of its life must be collected and returned to an authorized recycling facility.



www.jbctools.com