

# JBC

[www.jbctools.com](http://www.jbctools.com)

## INSTRUCTION MANUAL

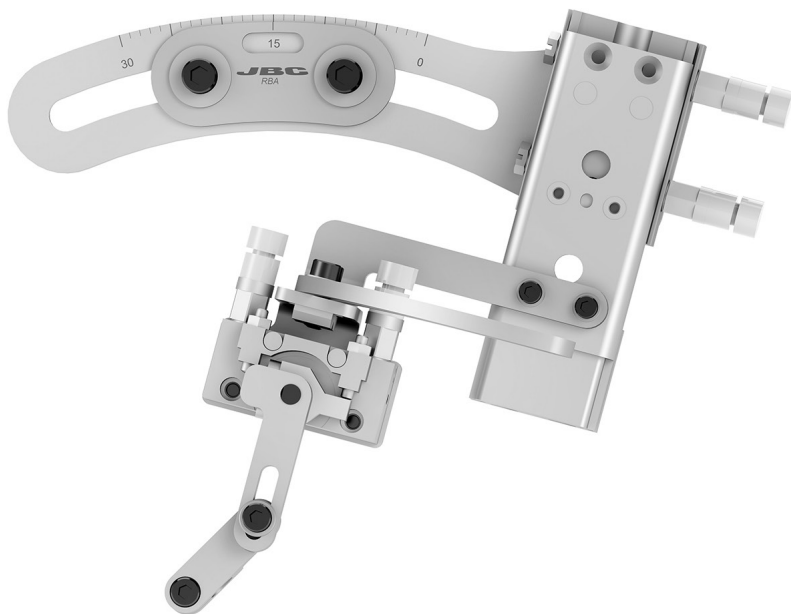

### RBA

Soldering Head for Robot

This manual corresponds to the following references:

RBA-A

## Packing List

The following items are included:

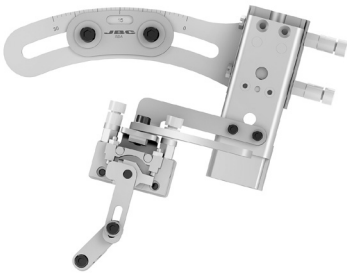

Soldering Head for Robot ..... 1 unit

Manual ..... 1 unit  
Ref. 0021309

## Assembly

The Robot needs a 18mm diameter axis to attach the **Soldering Head** by using the Clamp with its Insulator Bushing.

It is mandatory to have the electrical Insulator Bushing assembled for proper tool working.  
**Don't remove the Insulator.**

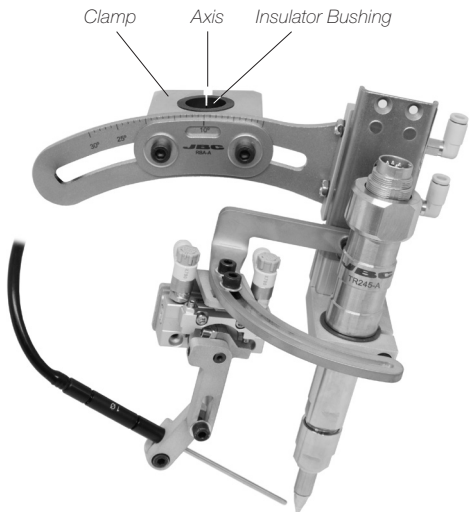

## Assembly with TR and SFR

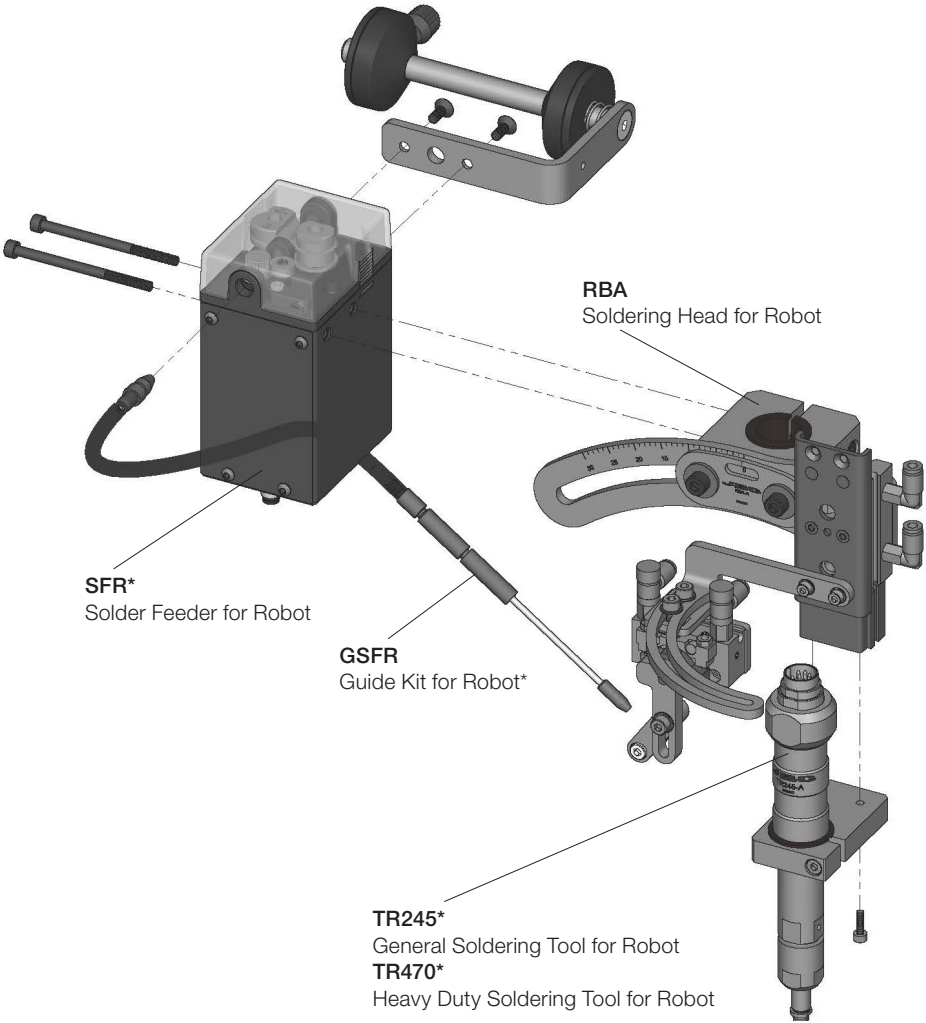

\*Not included, sold separately

# Assembly with TRA and SFR

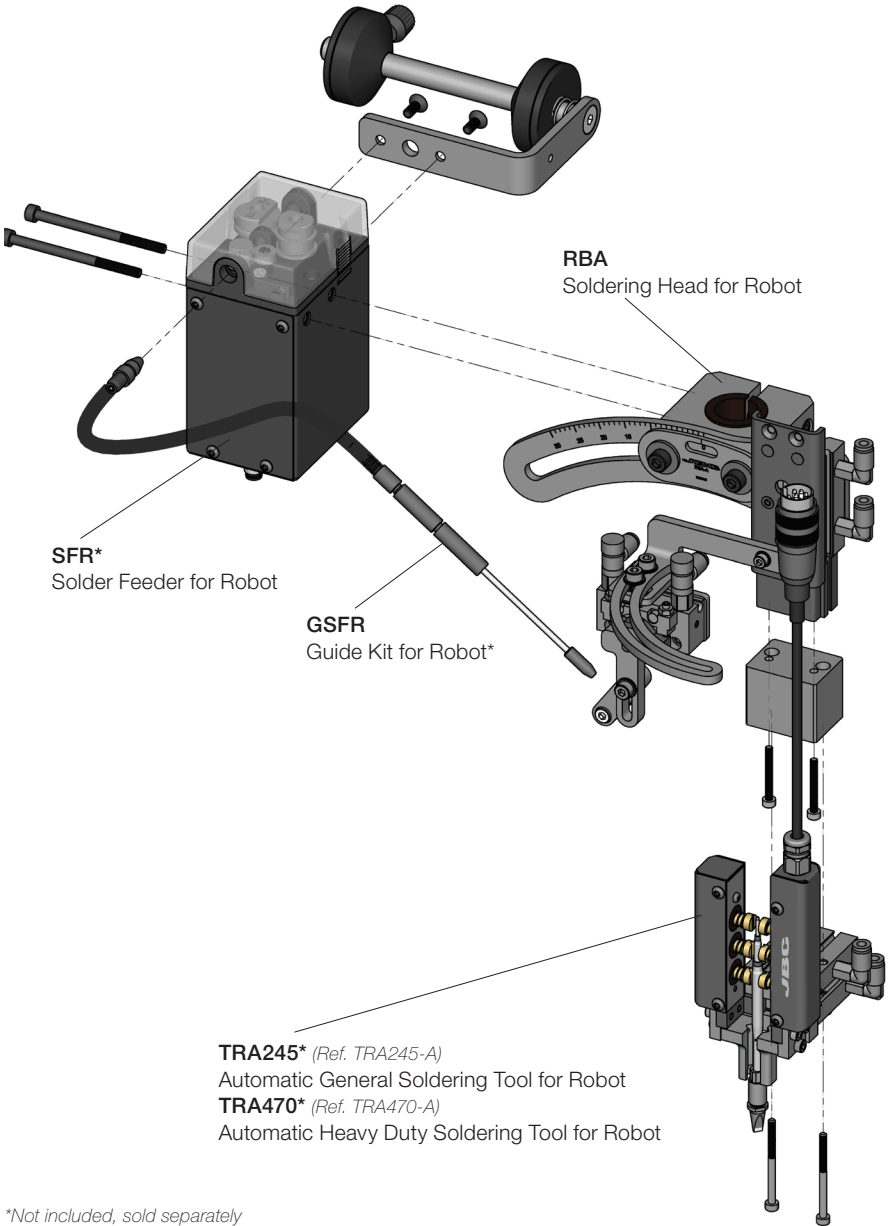

\*Not included, sold separately

## Adjustment

The **Soldering Head for Automation** allows adjustment of the Soldering Iron position, as well as the dispensing Nozzle position.

### Soldering Iron position adjustment

The angle of the Soldering Iron is adjustable from 0° to 30°. Loosen and tighten the M5 screws to change its position.

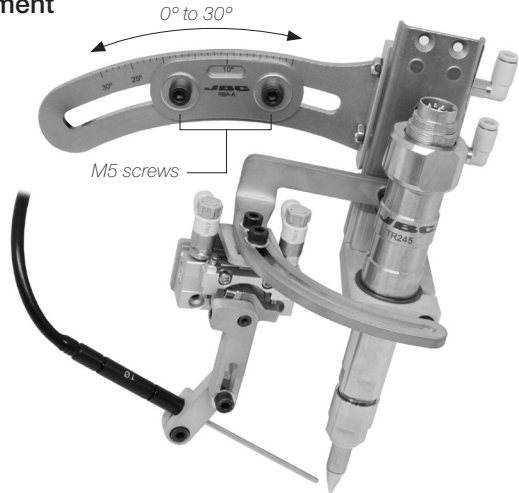

### Dispensing Nozzle position adjustment

The position of the Dispensing Nozzle is adjustable depending on your needs. Loosen and tighten the M4 screws to change its position.

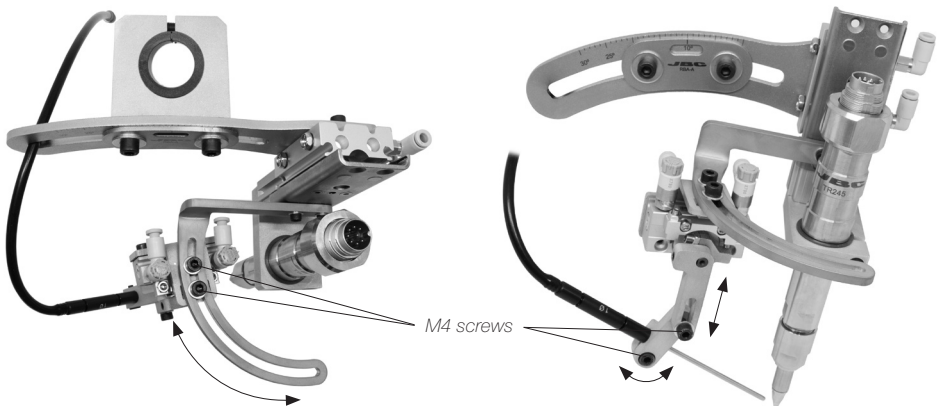

## Dispensing Nozzle movement adjustment

The movement of the Nozzle Actuator can be adjusted by regulating the following parts:

- By means of the two knobs, the upward (A) and the downward (B) movement speed can be throttled.
- The maximum angle of the Dispensing Nozzle movement is 90°. This angle can be reduced by screwing the grub screws (C) and (D).

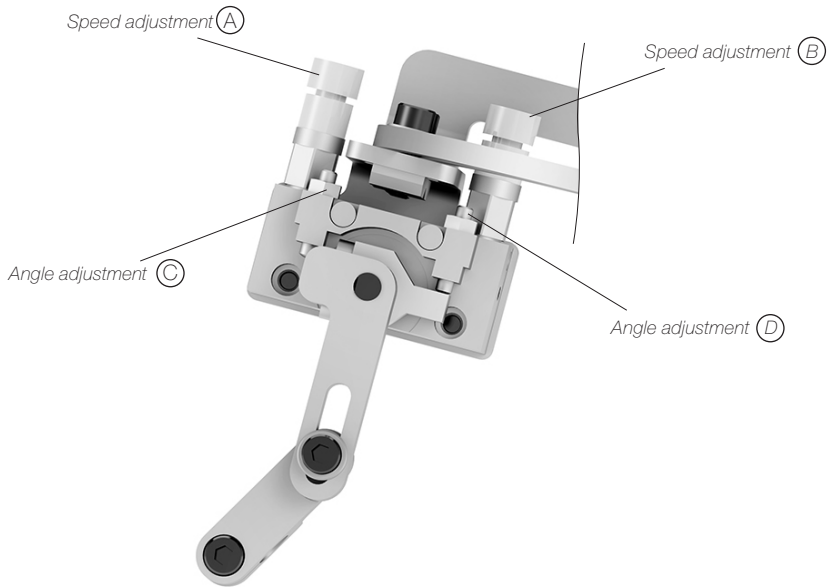

## Compatibility

Soldering Head	Soldering Tools			
	Ref. TR245-B	Ref. TR470-B	Ref. TRA245-A	Ref. TRA470-A
Ref. RBA-A	●	●	●	●

RBA, SFR, GSFR and CLR/CLRP are compatible with R245 and R470 cartridge ranges.

## Movements

The **Soldering Head for Automation** allows automatic movements through the following pneumatic actuators:

- Soldering Iron Actuator: with tube connection movement into (A) and away (B) from soldering position.
- Dispensing Nozzle Actuator: with tube connections for movement into (C) and away (D) from feeding position.

The Tool Actuator has a buffer of 5mm stroke to soften collision while soldering. You can adjust the Dispensing Nozzle Actuator speed by adjusting the fittings.

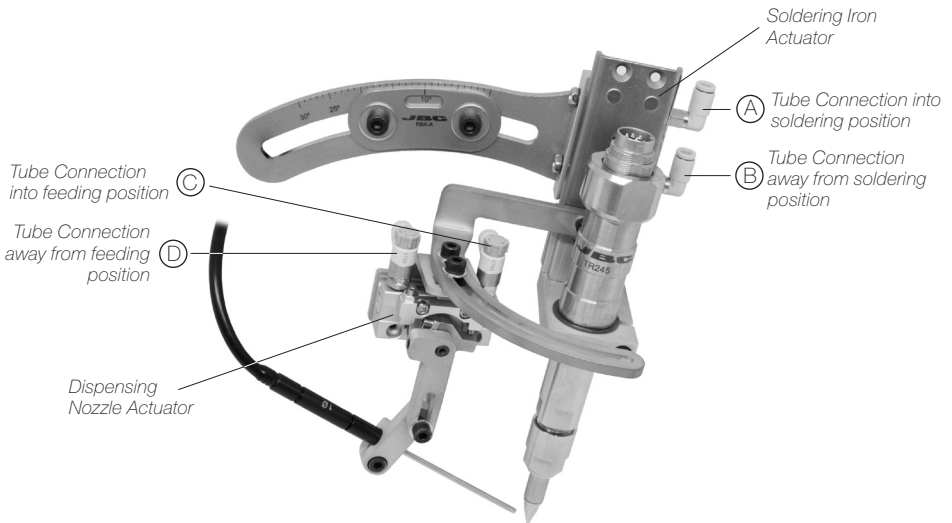

Soldering Iron Actuator	
Fluid	Air
Applicable tubing	Ø4mm
Operating pressure	1.5 to 7 bar 20 to 100 psi
Operating speed range	50 to 500 mm/s
Total Stroke	20mm

Dispensing Nozzle Actuator	
Fluid	Air
Applicable tubing	Ø4mm
Operating pressure	1.5 to 7 bar 20 to 100 psi
Operating speed	Adjustable
Rotation angle	90°

# Dimensions

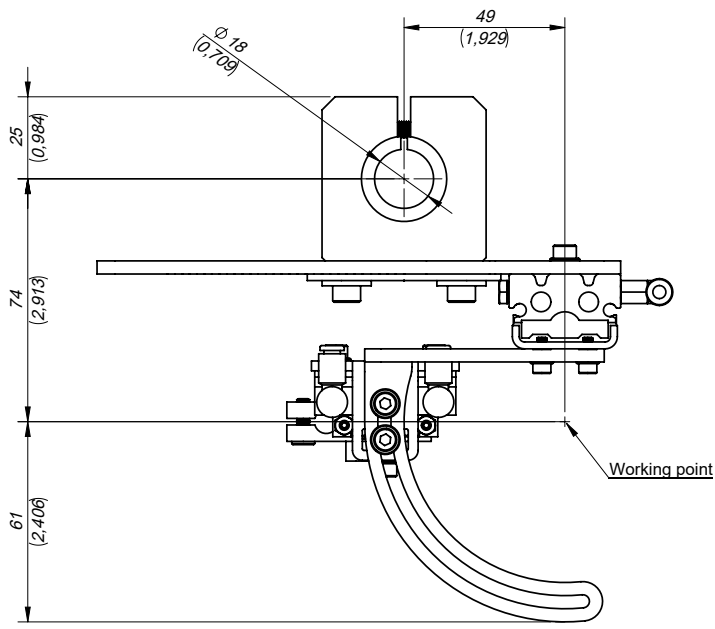
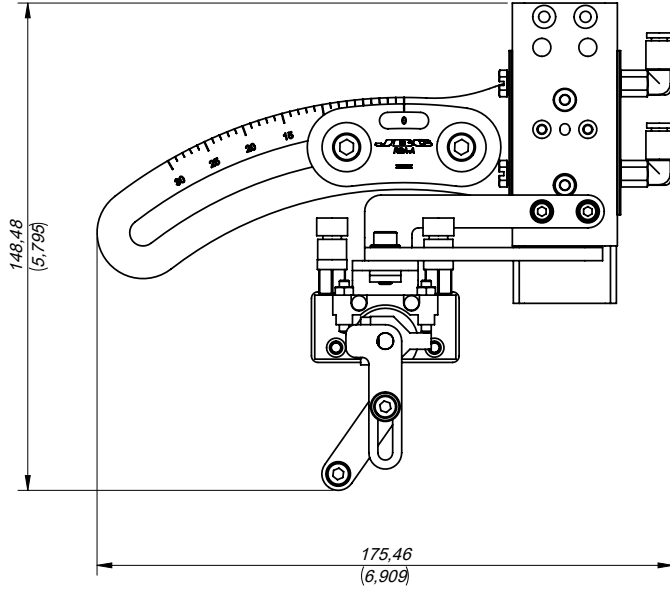

mm  
(in)



# Work Place Example

**Note:** RBA is included in Soldering Set HM245 (General Soldering) and HM470 (Heavy Duty Soldering)

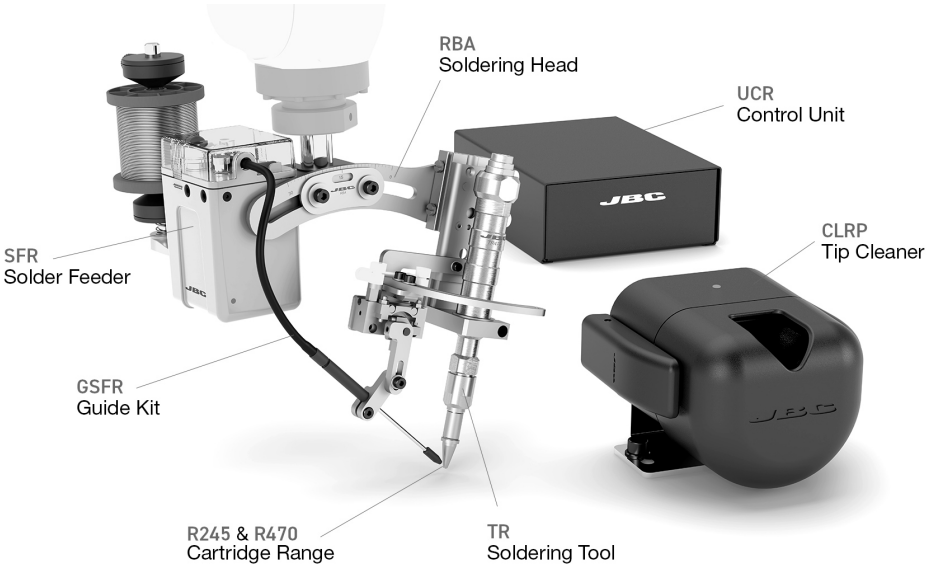

## Maintenance

- Before carrying out maintenance, always unplug the tool.
- Use a damp cloth to clean the tool. Alcohol can only be used to clean the metal parts.
- Periodically check that the metal parts of the tool are clean.
- Periodically check all cables and tube connections.
- Replace any defective or damaged pieces. Use original JBC spare parts only.
- Repairs should only be performed by a JBC authorized technical service.
- Under normal operating conditions, the air actuators lifespan is 10 million cycles. It is recommended to replace it at the end of its lifespan.

## Safety



**It is imperative to follow safety guidelines to prevent electric shock, injury, fire or explosion.**

- Do not use the tool for any purpose other than soldering or rework.
- The temperature of accessible surfaces may remain high after the unit is turned off. Handle with care.
- Avoid flux coming into contact with skin or eyes to prevent irritation.
- Be careful with the fumes produced while soldering.
- Keep your workplace clean and tidy. Wear appropriate protection glasses and gloves when working to avoid personal injury.
- Utmost care must be taken with liquid tin waste which can cause burns.



# Specifications

## RBA

### Soldering Head for Robot

Ref. RBA-A

- |   |   |
|---|---|
| - Soldering Tool Angle:                 | 0° to 30°                                   |
| - Pneumatic Stroke:                     | 20 mm / 0.787 in                            |
| - Buffer Stroke:                        | 5 mm / 0.197 in                             |
| - Operating Pressure:                   | 1.5 to 7 bar / 20 to 100 psi                |
| - Pneumatic Tube Diameter:              | ø4 mm / ø0.157 in                           |
| - Robot Axis Diameter for RBA Assembly: | ø18 mm / ø0.315 in                          |
|   |   |
| - Net Weight:                           | 576 g / 1.27 lb                             |
| - Dimensions:<br>(L x H x W)            | 176 x 148 x 160 mm<br>6.92 x 5.83 x 6.30 in |

Complies with CE standards.  
ESD safe.

# JBC

## Warranty

JBC's 2 year warranty covers this equipment against all manufacturing defects, including the replacement of defective parts and labour.

Warranty does not cover product wear or misuse.

In order for the warranty to be valid, equipment must be returned, postage paid, to the dealer where it was purchased.

**Get 1 extra year JBC warranty by registering here:**

**<https://www.jbctools.com/productregistration/>  
within 30 days of purchase.**



This product should not be thrown in the garbage.

In accordance with the European directive 2012/19/EU, electronic equipment at the end of its life must be collected and returned to an authorized recycling facility.

