

JBC

www.jbctools.com

INSTRUCTION MANUAL



TR

Soldering Iron for Robot

This manual corresponds to the following references:

- **TR245-B** works with R245 cartridges
- **TR470-B** works with R470 cartridges

Packing List

Either Ref. TR245-B or Ref. TR470-B is included.

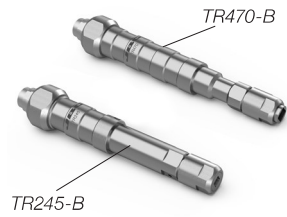

Soldering Iron 1 unit

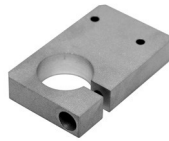

Clamp 1 unit
Ref. 0018779



Insulator 1 unit
Ref. 0020440



Screws
DIN 912 M3x10..... 2 units
Ref. 0722900



Screw
DIN 912 M4x16..... 1 unit
Ref. 0002984

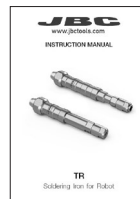

Manual 1 unit
Ref. 0028116

Assembly

**Soldering Iron
for Automation***
Ref. TR245-B

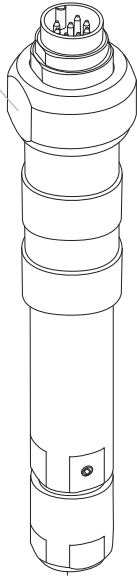

**Soldering Iron
for Automation***
Ref. TR470-B

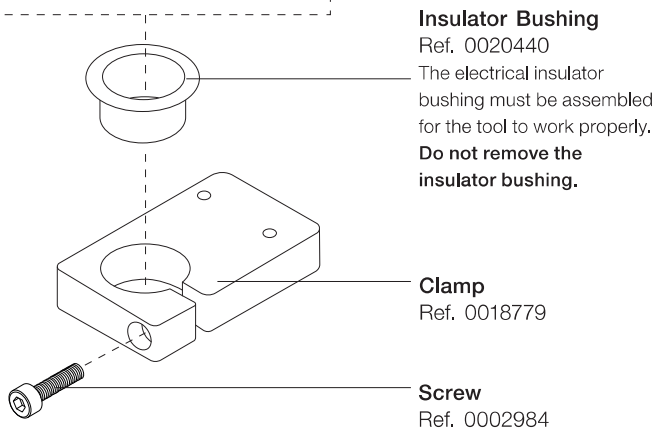
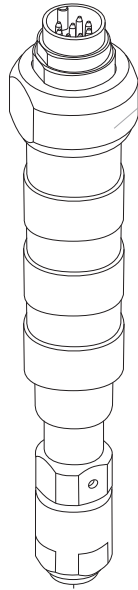

* If the Soldering Iron is attached in another way, it must be assembled at its fixation in an electrically isolated manner.

Assembly with RBA

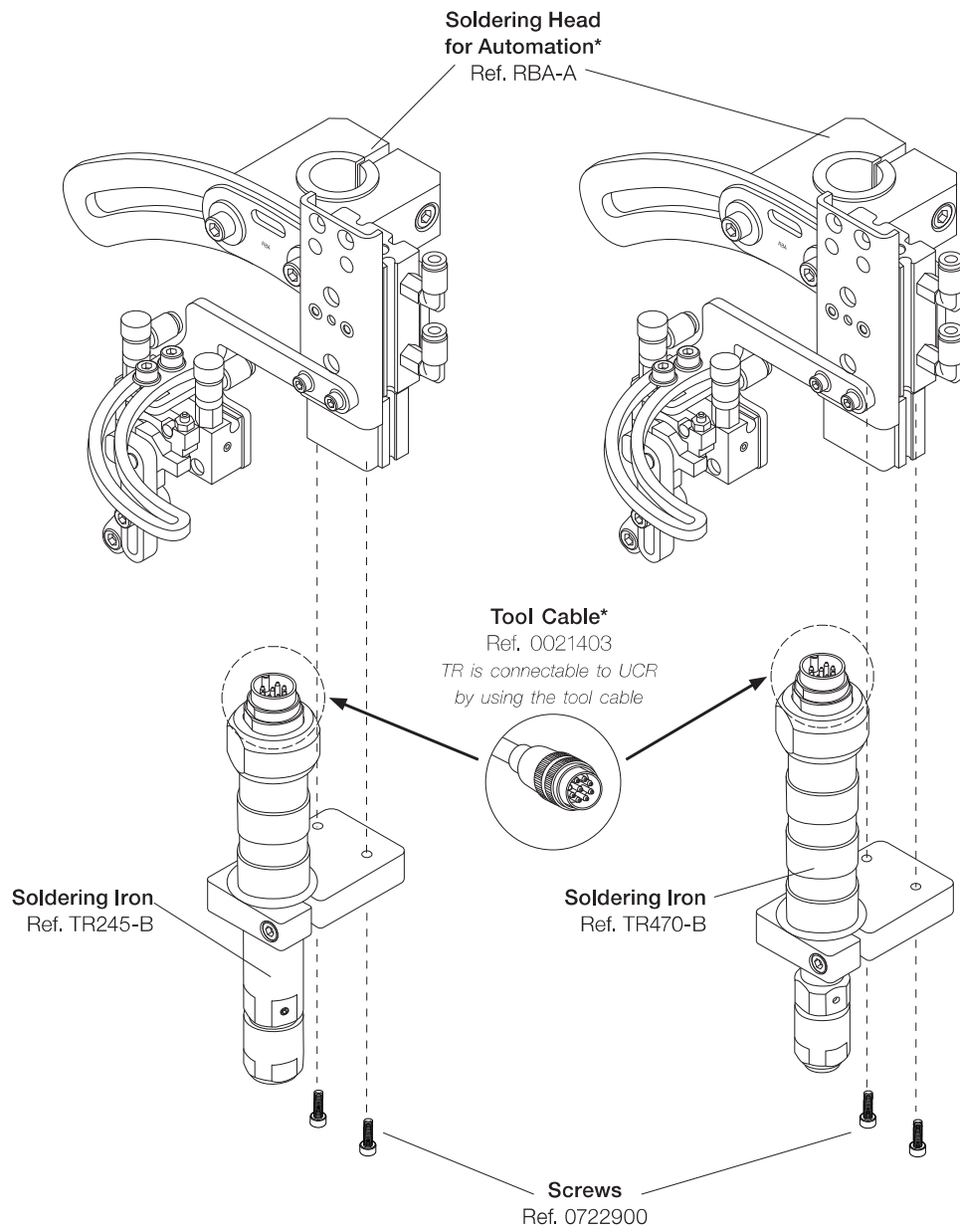

* Not included, sold separately

Inserting and Removing Cartridges

! For any hand operation make sure the power is off and both tool and cartridge are cold. Before removing or inserting the cartridge, make sure air pressure is off.

Insert the cartridge and press lightly until it is placed in the soldering iron (a). Use an allen key to fix the cartridge in the handle (b).

The square recess of the soldering iron must be matched with the square shape of the cartridge. Insert the cartridge until the two square shapes come to a limit stop inside.

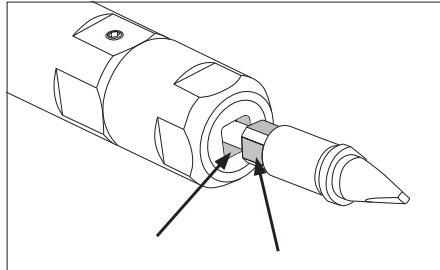
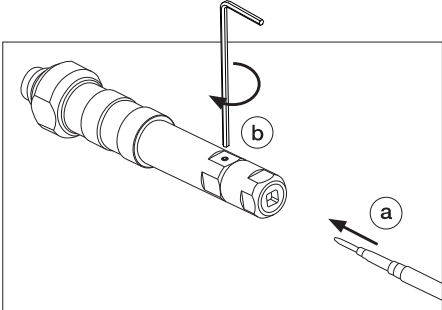

Compatibility

	Cartridge Range	Control Unit
TR245	R245	UCR245
TR470	R470	UCR470

RBA, SFR, GSFR and CLR are compatible with both R245 and R470 ranges.

Cartridge Range

Find the cartridge models that best suits your soldering needs in www.jbctools.com



Chisel



Pin / Connector



Drag

Dimensions

Soldering Iron
Ref. TR245-B

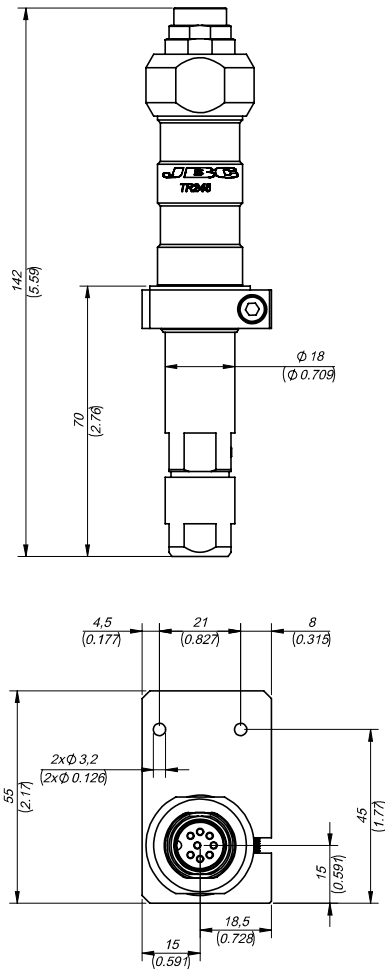

Soldering Iron
Ref. TR470-B

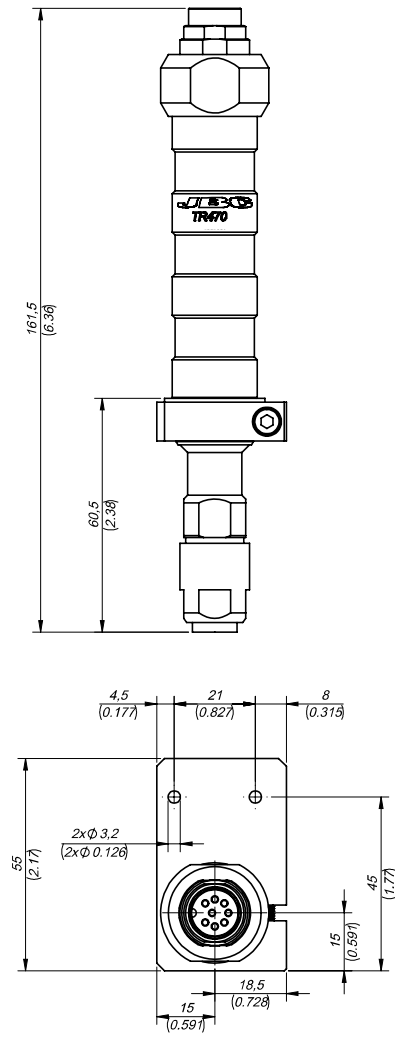

mm
(in)

Maintenance

- Before carrying out maintenance, always unplug the tool.
- Use a damp cloth to clean the tool. Alcohol can only be used to clean the metal parts.
- Periodically check that the metal parts of the tool are clean so the station can detect the tool status
- Periodically check all cable and tube connections.
- Maintain tip surface clean and tinned prior to storage in order to avoid tip oxidation. Rusty and dirty surfaces reduce heat transfer to the solder joint.
- Replace any defective or damaged part. Use original JBC spare parts only.
- Repairs should only be performed by a JBC authorized technical service.

Safety



It is imperative to follow safety guidelines to prevent electric shock, injury, fire or explosion.

- Do not use the soldering iron for any purpose other than soldering or rework. Incorrect use may cause fire.
- Do not leave the appliance unattended when it is on.
- Be sure that the power supply is disconnected before changing any spare part.
- The temperature of accessible surfaces may remain high after the unit is turned off. Handle with care.
- Allow cartridges to cool down before changing them.
- Heat can cause inflammable products to ignite even when not visible.
- Avoid flux coming into contact with skin or eyes to prevent irritation.
- Be careful with the fumes produced when soldering.
- Keep your workplace clean and tidy. Wear appropriate protective glasses and gloves when working to avoid personal injury.
- Utmost care must be taken with liquid tin waste which can cause burns.

Specifications

TR

Soldering Iron for Robot

Ref.: **TR245-B**

Ref.: **TR470-B**

Clamp only

- Net Weight: 44 gr / 0,10 lb
- Dimensions: 55 x 33.5 x 10 mm
(L x W x H) 2,17x 1,32 x 0,39 in

- Total Net Weight: **TR245-B** 230 g / 0.51 lb
- Dimensions: 142 x 28 mm
(L x W) 5,59 x 1,10 in

- Total Net Weight: **TR470-B** 236 g / 0.52 lb
- Dimensions: 161.5 x 28 mm
6,36 x 1,10 in

- Package Dimension / Weight: 283 x 79 x 56 mm / 319 g
(L x W x H) 11.14 x 3.11 x 2.20 in / 0.70 lb

283 x 79 x 56 mm / 325 g
11.14 x 3.11 x 2.20 in / 0.72 lb

Complies with CE standards.
ESD safe.

JBC

Warranty

JBC's 2 year warranty covers this equipment against all manufacturing defects, including the replacement of defective parts and labour.

Warranty does not cover product wear or misuse.

In order for the warranty to be valid, equipment must be returned, postage paid, to the dealer where it was purchased.



This product should not be thrown in the garbage.

In accordance with the European directive 2012/19/EU, electronic equipment at the end of its life must be collected and returned to an authorized recycling facility.



www.jbctools.com

0028118-0122