

JBC

www.jbctools.com

INSTRUCTION MANUAL



**SADS, SAPS, SAMS, SHTS,
SATS, SDSS, SDRS, SALS,
SDNS, SNHS, STES,
SJTS, SSFS, SWSBT**

Tool Holders for Stands

This manual corresponds to the following references*:

- | | |
|--|---|
| 0015450 <i>SADS for ADS & HDS</i> | 0016267 <i>SAPS for APS</i> |
| 0016268 <i>SAMS for AMS</i> | 0016269 <i>SHTS for HTS & HDTS</i> |
| 0028036 <i>SATS for ATS</i> | 0016272 <i>SDSS for DSS</i> |
| 0016273 <i>SDRS for DRS</i> | 0016275 <i>SALS for ALS</i> |
| 0016274 <i>SDNS for DNS</i> | 0028410 <i>SNHS for NHS</i> |
| 0016227 <i>STES for TES</i> | 0016276 <i>SJTS for JTS</i> |
| 0018634 <i>SSFS for SFS</i> | 0028411 <i>SWSBT for WSBT</i> |

Packing List

The following items are included:

- | | |
|---|--|
| Tool Holder 1 unit
<i>*according to purchased reference</i> | Manual 1 unit
Ref. 0028444 |
|---|--|

Replacement



Before carrying out maintenance, always unplug the tool.
Allow the equipment to cool down. Be sure that the power supply is disconnected before changing any spare part.

Changing the Tool Holder

Remove the locking knob (1).

Separate the tool holder from the stand and remove the holder screw (2).

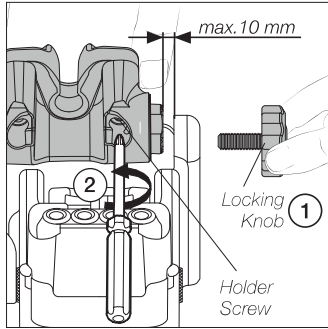

Carefully move the tool holder sideways until the cable* comes out (3).

Place the new tool holder following the disassembling steps conversely.

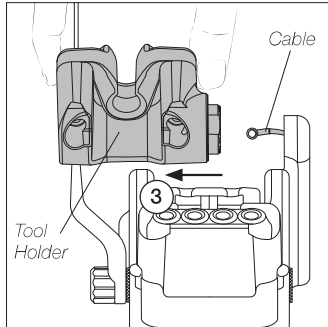

*The following references come without cable connection:

- Ref. 0018634 SSFS for SFS
- Ref. 0028411 SWSBT for WSBT

Specifications

SADS / SAPS / SAMS / SHTS / SATS / SDSS / SDRS /
SALS / SDNS / SNHS / STES / SJTS / SSFS / SWSBT

Tool Holders for Stands

Ref.: see page 2

- Package Dimensions: 111 x 81 x 41 mm
(L x W x H) 4.37 x 3.19 x 1.61 in

Complies with CE standards.

JBC

Warranty

JBC's 2 year warranty covers this equipment against all manufacturing defects, including the replacement of defective parts and labour.

Warranty does not cover product wear or misuse.

In order for the warranty to be valid, equipment must be returned, postage paid, to the dealer where it was purchased.



This product should not be thrown in the garbage.

In accordance with the European directive 2012/19/EU, electronic equipment at the end of its life must be collected and returned to an authorized recycling facility.



www.jbctools.com

0028444-0122