

Keithley Instruments
 28775 Aurora Road
 Cleveland, Ohio 44139
 1-800-833-9200
tek.com/keithley

System SourceMeter® Instrument Specifications

SPECIFICATION CONDITIONS

This document contains specifications and supplemental information for the Models 2601B, 2602B, and 2604B System SourceMeter® instrument. Specifications are the standards against which the Models 2601B, 2602B, and 2604B are tested. Upon leaving the factory, the Models 2601B, 2602B, and 2604B meet these specifications. Supplemental and typical values are nonwarranted, apply at 23 °C, and are provided solely as useful information.

Source and measurement accuracies are specified at the Models 2601B, 2602B, and 2604B terminals under these conditions:

- 18 °C to 28 °C, < 70 percent relative humidity
- After a two-hour warm-up period
- Speed normal (1 NPLC)
- A/D autozero enabled
- Remote sense operation or properly zeroed local operation
- Calibration period: One year

DC POWER SPECIFICATIONS

	Voltage	Current
Maximum output power and source/sink limits¹	40.4 W maximum <ul style="list-style-type: none"> ▪ ± (40.4 V at 1.0 A, -1.0 A) ▪ ± (6.06 V at 3.0 A, -3.0 A) ▪ Four-quadrant source or sink operation 	40.4 W maximum <ul style="list-style-type: none"> ▪ ± (1.01 A at 40 V, -40 V) ▪ ± (3.03 A at 6 V, -6 V) ▪ Four-quadrant source or sink operation

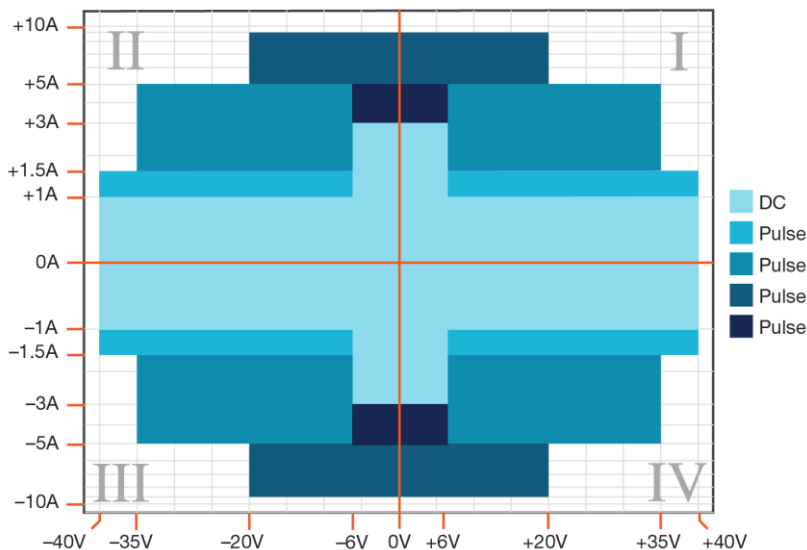

¹ Full power source operation regardless of load to 30 °C ambient temperature. Above 30 °C or power sink operation, refer to “Operating Boundaries” in the *Series 2600B System SourceMeter Instrument Reference Manual* for additional power derating information.



Refer to [Pulse characteristics](#) for pulsing details, such as duty cycle and pulse width.

VOLTAGE ACCURACY SPECIFICATIONS^{2,3}

Range	Source			Measure	
	Programming resolution	Accuracy ± (% reading + volts)	Typical noise (peak to peak) 0.1 Hz to 10 Hz	Display resolution	Accuracy ⁴ ± (% reading + volts)
100 mV	5 µV	0.02% + 250 µV	20 µV	100 nV	0.015% + 150 µV
1 V	50 µV	0.02% + 400 µV	50 µV	1 µV	0.015% + 200 µV
6 V	50 µV	0.02% + 1.8 mV	100 µV	1 µV	0.015% + 1 mV
40 V	500 µV	0.02% + 12 mV	500 µV	10 µV	0.015% + 8 mV

CURRENT ACCURACY SPECIFICATIONS²

Range	Source			Measure	
	Programming resolution	Accuracy ± (% reading + amperes)	Typical noise (peak to peak) 0.1 Hz to 10 Hz	Display resolution	Accuracy ⁴ ± (% reading + amperes)
100 nA	2 pA	0.1% + 100 pA	5 pA	100 fA	0.08% + 100 pA
1 µA	20 pA	0.03% + 800 pA	25 pA	1 pA	0.025% + 500 pA
10 µA	200 pA	0.03% + 5 nA	60 pA	10 pA	0.025% + 1.5 nA
100 µA	2 nA	0.03% + 60 nA	3 nA	100 pA	0.02% + 25 nA
1 mA	20 nA	0.03% + 300 nA	6 nA	1 nA	0.02% + 200 nA
10 mA	200 nA	0.03% + 6 µA	200 nA	10 nA	0.02% + 2.5 µA
100 mA	2 µA	0.03% + 30 µA	600 nA	100 nA	0.02% + 20 µA
1 A	20 µA	0.05% + 1.8 mA	70 µA	1 µA	0.03% + 1.5 mA
3 A	20 µA	0.06% + 4 mA	150 µA	1 µA	0.05% + 3.5 mA
10 A ⁵	200 µA	0.5% + 40 mA	N/A	10 µA	0.4% + 25 mA

² For temperatures 0 °C to 18 °C and 28 °C to 50 °C, accuracy is degraded by ± (0.15 × accuracy specification)/°C. High Capacitance Mode accuracy is applicable at 23 °C ± 5 °C.

³ Add 50 µV to source accuracy specifications per volt of HI lead drop.

⁴ Derate accuracy specification for NPLC setting < 1 by increasing the error term. Add appropriate typical percent of reading term for resistive loads using the table below.

NPLC setting	100 mV range	1 V and 40 V ranges	100 nA range	1 µA to 100 mA ranges	1 A to 3 A ranges
0.1	0.01%	0.01%	0.01%	0.01%	0.01%
0.01	0.08%	0.07%	0.1%	0.05%	0.05%
0.001	0.8%	0.6%	1%	0.5%	1.1%

⁵ 10 A range is accessible in pulse mode only. Accuracy specifications for 10 A range are typical.

SUPPLEMENTAL CHARACTERISTICS

The following specifications are supplemental characteristics that provide additional information about instrument functions and performance. These characteristics are nonwarranted specifications; they describe the typical performance of the Models 2601B, 2602B and 2604B.

PULSE CHARACTERISTICS

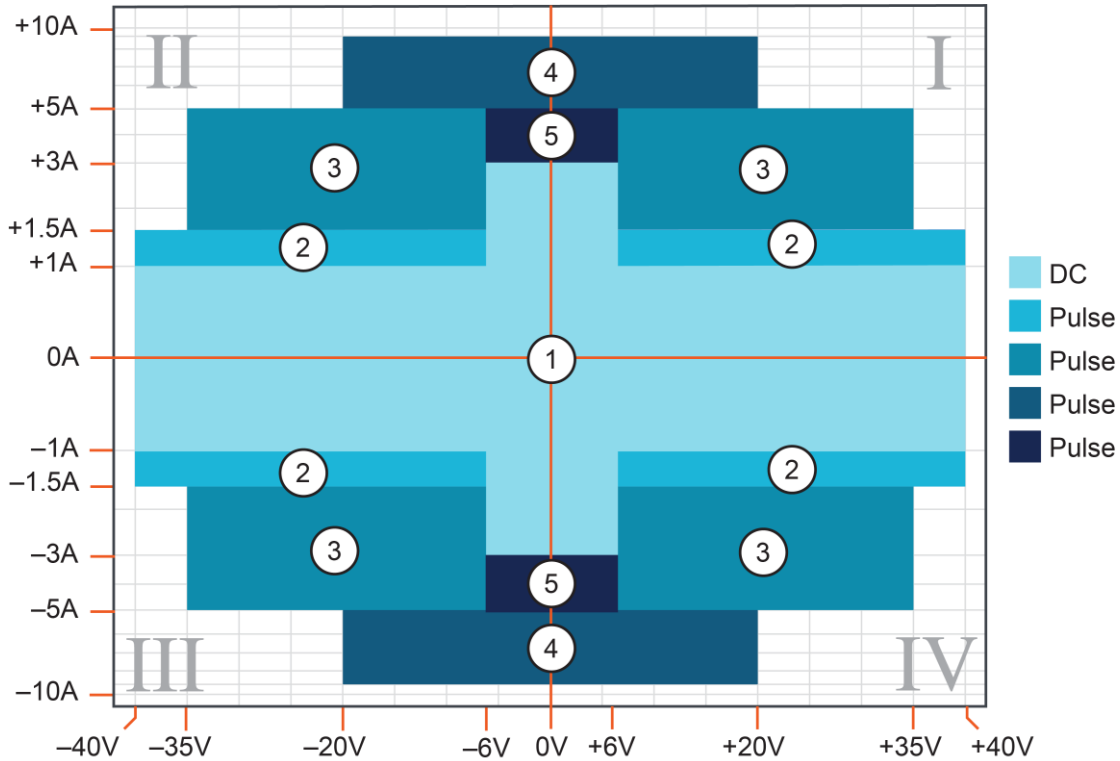

Pulse region specifications			
Region quadrant diagram	Region maximums	Maximum pulse width ⁶	Maximum duty cycle ⁷
1	1 A at 40 V	DC, no limit	100%
1	3 A at 6 V	DC, no limit	100%
2	1.5 A at 40 V	100 ms	25%
3	5 A at 35 V	4 ms	4%
4	10 A at 20 V	1.8 ms	1%
5	5 A at 6 V	10 ms	10%

⁶ Times measured from the start of the pulse to the start of the off-time; see figure below.

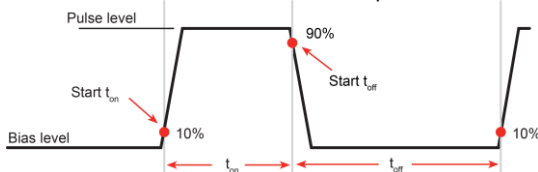

⁷ Thermally limited in sink mode (quadrants 2 and 4) and ambient temperatures above 30 °C. See power equations in the *Series 2600B System SourceMeter Instrument Reference Manual* for more information.

Minimum programmable pulse width⁶	100 μ s Note: Minimum pulse width for settled source at a given I/V output and load can be longer than 100 μ s.			
	Source value	Load	Source settling (% of range)	Minimum pulse time to settle
	6 V	2 Ω	0.2%	150 μ s
	20 V	2 Ω	1%	200 μ s
	35 V	7 Ω	0.5%	500 μ s
	40 V	27 Ω	0.1%	400 μ s
	1.5 A	27 Ω	0.1%	1.5 ms
	3 A	2 Ω	0.2%	150 μ s
	5 A	7 Ω	0.5%	500 μ s
10 A	2 Ω	0.5%	200 μ s	
Pulse width programming resolution	1 μ s			
Pulse width programming accuracy	\pm 5 μ s			
Pulse width jitter	2 μ s			

ADDITIONAL SOURCE CHARACTERISTICS

Noise 10 Hz to 20 MHz	< 20 mV peak-peak, < 3 mV RMS <ul style="list-style-type: none"> ▪ 6 V range
Transient response time	< 70 μ s for the output to recover to within 0.1% for a 10% to 90% step change in load
Overshoot	Voltage: <ul style="list-style-type: none"> ▪ < \pm0.1% + 10 mV ▪ Step size = 10% to 90% of range, resistive load, maximum current limit/compliance Current: <ul style="list-style-type: none"> ▪ < \pm0.1% ▪ Step size = 10% to 90% of range, resistive load ▪ See Current source output settling time for additional test conditions
Range change overshoot	Voltage: ⁸ <ul style="list-style-type: none"> ▪ < 500 mV + 0.1% of larger range or < 300 mV + 0.5% of larger range ▪ Overshoot into a 100 kΩ load, 20 MHz bandwidth Current: ⁹ <ul style="list-style-type: none"> ▪ < 300 mV/R_{LOAD} + 5% of larger range
Guard offset voltage	< 4 mV <ul style="list-style-type: none"> ▪ Current < 10 mA

⁸ Add 180 mV for the 6 V to 20 V change (500 mA).⁹ With source settling set to SETTLE_SMOOTH_100NA.

Remote sense operating range¹⁰	Maximum voltage between HI and SENSE HI = 3 V Maximum voltage between LO and SENSE LO = 3 V	
Voltage output headroom	40 V range <ul style="list-style-type: none"> Maximum output voltage = 42 V – (total voltage drop across source leads); maximum 1 Ω source lead 6 V range <ul style="list-style-type: none"> Maximum output voltage = 8 V – (total voltage drop across source leads); maximum 1 Ω source lead 	
Overtemperature protection	Internally sensed overtemperature condition puts the instrument in standby mode	
Limit/compliance	Bipolar limit (compliance) set with a single value Voltage: ¹¹ <ul style="list-style-type: none"> Minimum value is 10 mV; accuracy is the same as voltage source Current: ¹² <ul style="list-style-type: none"> Minimum value is 10 nA; accuracy is the same as current source 	
Voltage source output settling time	Time required to reach within 0.1% of final value after source level command is processed on a fixed range.	
	Voltage range	Settling time
	100 mV	< 50 μs
	1 V	< 50 μs
	6 V	< 110 μs
40 V ¹³	< 150 μs	
Current source output settling time	Time required to reach within 0.1% of final value after source level command is processed on a fixed range <ul style="list-style-type: none"> Values below for $I_{OUT} \times R_{LOAD} = 1 V$ 	
	Current range	Settling time
	100 nA	< 20 ms
	1 μA	< 2 ms
	10 μA	< 500 μs
	100 μA	< 150 μs
	1 mA	< 100 μs
	1 A to 10 mA	< 80 μs ($R_{LOAD} > 6 \Omega$)
	3 A	< 80 μs (Current < 2.5 A, $R_{LOAD} > 2 \Omega$)

¹⁰ Add 50 μV to source accuracy specifications per volt of HI lead drop.

¹¹ For sink operation (quadrants II and IV) without sink mode enabled, add 10% of compliance range and ±0.02% of limit settling to the corresponding voltage source accuracy specifications. For 100 mV range add an additional 60 mV of uncertainty. Specifications apply with sink mode enabled.

¹² For sink operation (quadrants II and IV) without sink mode enabled, add 0.06% of limit range to the corresponding current limit accuracy specifications. Specifications apply with sink mode enabled.

¹³ Add 150 μs when measuring on the 1 A range.

ADDITIONAL MEASUREMENT CHARACTERISTICS

Contact check specifications ^{14, 15}	Speed	Maximum measurement time to memory for 60 Hz (50 Hz)	Accuracy (1 year) 23 °C ± 5 °C ± (% reading + ohms)
	Fast	1.1 ms (1.2 ms)	5% + 10 Ω
	Medium	4.1 ms (5 ms)	5% + 1 Ω
	Slow	36 ms (42 ms)	5% + 0.3 Ω
Current measure settling time ¹⁶	Time required to reach within 0.1% of final value after source level command is processed on a fixed range Values below for V _{OUT} = 1 V		
	Current range	Settling time	
	1 mA	< 100 μs	
Input impedance	> 10 GΩ		

ADDITIONAL CHARACTERISTICS

Maximum load impedance	Normal mode 10 nF	High-capacitance mode 50 μF
Common mode voltage	250 V DC	
Common mode isolation	> 1 GΩ < 4500 pF	
Sense high input impedance	> 10 GΩ	
Maximum sense lead resistance	1 kΩ for rated accuracy	
Overrange	101% of source range 102% of measure range	

¹⁴ Includes measurement of SENSE HI to HI and SENSE LO to LO contact resistances.

¹⁵ Contact check is not available with the Model 2604B.

¹⁶ Compliance equal to 100 mA

HIGH CAPACITANCE MODE^{17,18,19}

Accuracy specifications	Accuracy specifications are applicable in both Normal and High Capacitance Modes.	
Voltage source output settling time	Time required to reach within 0.1% of final value after source level command is processed on a fixed range. Current limit = 1 A	
	Voltage range	Settling time with C_{LOAD} = 4.7 μF
	100 mV	< 200 μs
	1 V	< 200 μs
	6 V	< 200 μs
	40 V	< 7 ms
Current measure settling time	Time required to reach within 0.1% of final value after source level command is processed on a fixed range Values below for V _{OUT} = 1 V unless noted	
	Current range	Settling time
	1 μA	< 230 ms
	10 μA	< 230 ms
	100 μA	< 3 ms
	1 mA	< 3 ms
	100 mA and 10 mA	< 100 μs
	3 A and 1 A	< 120 μs (R _{LOAD} > 2 Ω)
Capacitor leakage performance using the KIHighC factory script²⁰	200 ms at 50 nA <ul style="list-style-type: none"> ▪ Load = 5 μF in parallel with 10 MΩ ▪ Test: 5 V step and measure 	
Mode change delay	Current ranges of 100 μA and above: <ul style="list-style-type: none"> ▪ 11 ms delay for both in and out of High Capacitance Mode Current ranges below 100 μA: <ul style="list-style-type: none"> ▪ 250 ms delay into High Capacitance Mode ▪ 11 ms delay out of High Capacitance Mode 	
Voltmeter input impedance	10 GΩ in parallel with 3300 pF	
Noise 10 Hz to 20 MHz	< 30 mV peak-peak <ul style="list-style-type: none"> ▪ 6 V range 	
Range change overshoot	Voltage: <ul style="list-style-type: none"> ▪ < 400 mV + 0.1% of larger range ▪ Overshoot into a 100 kΩ load, 20 MHz bandwidth 	

¹⁷ High Capacitance Mode specifications are for dc measurements only.¹⁸ 100 nA range is not available in High Capacitance Mode.¹⁹ High Capacitance Mode utilizes locked ranges. Autorange is disabled.²⁰ Part of KI Factory scripts. See the *Series 2600B System SourceMeter Instrument Reference Manual* for details.

MEASUREMENT SPEED CHARACTERISTICS^{21,22}**Maximum sweep operation rates (operations per second) for 60 Hz (50 Hz):**

A/D converter speed	Trigger origin	Measure to memory (using user scripts)	Measure to GPIB (using user scripts)	Source measure to memory (using user scripts)	Source measure to GPIB (using user scripts)	Source measure to memory (using sweep API)	Source measure to GPIB (using sweep API)
0.001 NPLC	Internal	20000 (20000)	9800 (9800)	7000 (7000)	6200 (6200)	12000 (12000)	5900 (5900)
0.001 NPLC	Digital I/O	8100 (8100)	7100 (7100)	5500 (5500)	5100 (5100)	11200 (11200)	5700 (5700)
0.01 NPLC	Internal	4900 (4000)	3900 (3400)	3400 (3000)	3200 (2900)	4200 (3700)	4000 (3500)
0.01 NPLC	Digital I/O	3500 (3100)	3400 (3000)	3000 (2700)	2900 (2600)	4150 (3650)	3800 (3400)
0.1 NPLC	Internal	580 (480)	560 (470)	550 (465)	550 (460)	560 (470)	545 (460)
0.1 NPLC	Digital I/O	550 (460)	550 (460)	540 (450)	540 (450)	560 (470)	545 (460)
1.0 NPLC	Internal	59 (49)	59 (49)	59 (49)	59 (49)	59 (49)	59 (49)
1.0 NPLC	Digital I/O	59 (49)	59 (49)	59 (49)	59 (49)	59 (49)	59 (49)

Maximum single measurement rates (operations per second) for 60 Hz (50 Hz):

A/D converter speed	Trigger origin	Measure to GPIB	Source measure to GPIB	Source measure pass/fail to GPIB
0.001 NPLC	Internal	1900 (1800)	1400 (1400)	1400 (1400)
0.01 NPLC	Internal	1450 (1400)	1200 (1200)	1100 (1100)
0.1 NPLC	Internal	450 (390)	425 (370)	425 (375)
1.0 NPLC	Internal	58 (48)	57 (48)	57 (48)

²¹ Tests performed with a Model 2602B using the following equipment: Computer hardware (Intel® Pentium® 4 2.4 GHz, 2 GB RAM, National Instruments™ PCI-GPIB); driver (NI-488.2 Version 2.2 PCI-GPIB); software (Microsoft® Windows® XP, Microsoft® Visual Studio® 2010, VISA™ version 4.1).

²² Exclude current measurement ranges less than 1 mA.

Maximum measurement range change rate	> 7000 per second for > 10 μ A. When changing to or from a range \geq 1 A, maximum rate is > 2200/second.
Maximum source range change rate	> 400 per second > 10 μ A. When changing to or from a range \geq 1 A, maximum rate is > 190/second.
Maximum source function change rate	> 1000 per second
Command processing time	< 1 ms <ul style="list-style-type: none"> ▪ Maximum time required for the output to begin to change after receiving the <code>smua.source.levelv</code> or <code>smua.source.leveli</code> command.

TRIGGERING AND SYNCHRONIZATION CHARACTERISTICS

Triggering

Trigger in to trigger out	0.5 μ s
Trigger in to source change²³	10 μ s
Trigger timer accuracy	\pm 2 μ s
Source change²³ after LXI trigger	280 μ s

Synchronization

Multi-node synchronized source change²³	< 0.5 μ s
Single-node synchronized source change²³	< 0.5 μ s

SUPPLEMENTAL INFORMATION

Front-panel interface	Two-line vacuum fluorescent display (VFD) with keypad and navigation wheel
Display	<ul style="list-style-type: none"> ▪ Show error messages and user-defined messages ▪ Display source and limit settings ▪ Show current and voltage measurements ▪ View measurements stored in dedicated reading buffers

²³ Fixed source range with no polarity change.

Keypad operations	<ul style="list-style-type: none"> ▪ Change host interface settings ▪ Save and restore instrument setups ▪ Load and run factory and user-defined test scripts that prompt for input and send results to the display ▪ Store measurements into dedicated reading buffers
Programming	Embedded Test Script Processor (TSP®) accessible from any host interface; responds to high-speed test scripts comprised of remote commands and statements (for example, branching, looping, and math); able to execute test scripts stored in memory without host intervention.
Minimum user memory available	16 MB (approximately 250,000 lines of TSP code)
Reading buffers	<p>Nonvolatile memory uses dedicated storage areas reserved for measurement data. Reading buffers are arrays of measurement elements. Each element can store the following items:</p> <ul style="list-style-type: none"> ▪ Measurement ▪ Source setting (at the time the measurement was taken) ▪ Measurement status ▪ Range information ▪ Timestamp <p>Reading buffers can be filled using the front-panel STORE key and retrieved using the RECALL key or host interface.</p>
Buffer size, with timestamp and source setting	> 60,000 samples
Buffer size, without timestamp and source setting	> 140,000 samples

TIMING

Timer	Free-running 47-bit counter with 1 MHz clock input. Reset each time instrument power is turned on. If the instrument is not turned off, the timer is automatically reset to zero (0) every four years.
Timestamp	TIMER value is automatically saved when each measurement is triggered
Resolution	1 μ s
Timestamp accuracy	\pm 100 ppm

GENERAL SPECIFICATIONS

IEEE-488	IEEE Std 488.1 compliant. Supports IEEE Std 488.2 common commands and status model topology
RS-232	<ul style="list-style-type: none"> ▪ Baud rates from 300 bps to 115,200 bps ▪ Programmable number of data bits, parity type, and flow control (RTS/CTS hardware or none) ▪ When not programmed as the active host interface, the Models 2601B, 2602B and 2604B can use the RS-232 interface to control other instruments
Ethernet	RJ-45 connector, LXI version 1.4 Core 2011, 10/100BaseT, Auto-MDIX
LXI compliance	LXI version 1.4 Core 2011
Expansion interface²⁴	<ul style="list-style-type: none"> ▪ The TSP-Link[®] expansion interface allows TSP-enabled instruments to trigger and communicate with each other ▪ Cable type: Category 5e or higher LAN crossover cable ▪ Three meter (9.84 ft) maximum between each TSP-enabled instrument ▪ A maximum of 32 TSP-Link nodes can be interconnected ▪ Each source-measure instrument uses one TSP-Link node
USB Control (Rear)	USB 2.0 Device: USB-TMC488 protocol
USB File System (Front)	USB 2.0 Host: Mass storage class device
Power supply	100 V ac to 240 V ac, 50 Hz or 60 Hz (autosensing), 240 VA maximum
Cooling	Forced air; side intake and rear exhaust; one side must be unobstructed when rack mounted
Warranty	1 year
EMC	Conforms to European Union EMC Directive
Safety	NRTL listed to UL61010-1:2008 and CSA C22.2 No. 61010-1 Conforms to European Union Low Voltage Directive
Environment	For indoor use only Altitude: Maximum 2000 m (6562 ft) above sea level Operating: 0 °C to 50 °C, 70% relative humidity up to 35 °C. Derate 3% relative humidity/°C, 35 °C to 50 °C Storage: -25 °C to 65 °C
Dimensions	Rack mount: 89 mm high × 213 mm wide × 460 mm deep (3.5 in. × 8.4 in. × 17.5 in.) Bench configuration (with handle and feet): 104 mm high × 238 mm wide × 460 mm deep (4.1 in. × 9.4 in. × 17.5 in.)
Weight	2601B: 4.75 kg (10.4 lb) 2602B and 2604B: 5.50 kg (12.0 lb)

²⁴ TSP-Link is not available with the Model 2604B.

Digital I/O interface²⁵

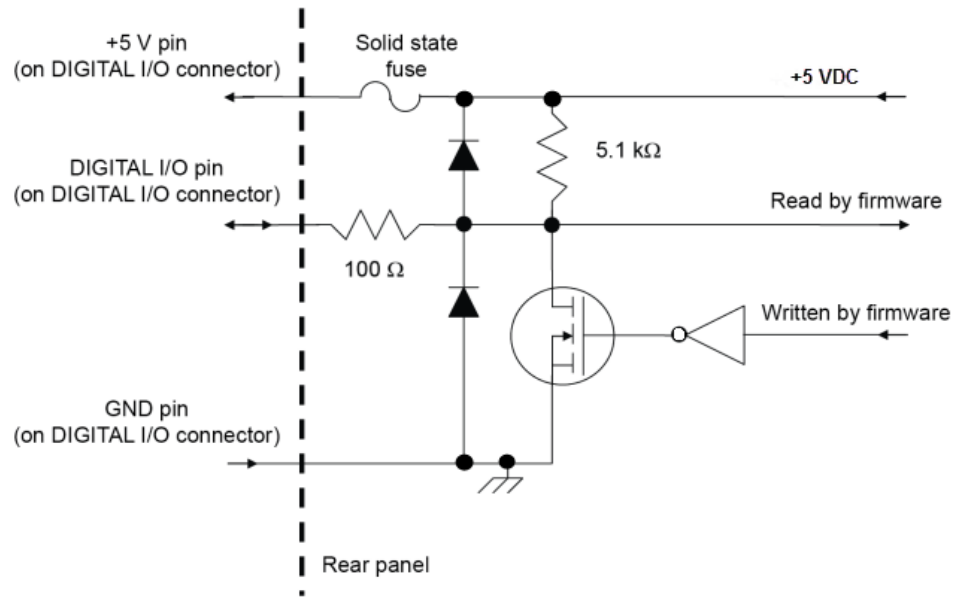

Connector: 25-pin female D

Input/output pins: 14 open drain I/O bits

Absolute maximum input voltage: 5.25 V

Absolute minimum input voltage: -0.25 V

Maximum logic low input voltage: 0.7 V, +850 μA maximum

Minimum logic high input voltage: 2.1 V, +570 μA

Maximum source current (flowing out of digital I/O bit): +960 μA

Maximum sink current at maximum logic low voltage (0.7 V): -5.0 mA

Absolute maximum sink current (flowing into digital I/O pin): -11 mA

5 V power supply pins: Limited to 250 mA total, solid-state fuse protected

Output Enable: Active high input pulled down internally to ground with a 10 kΩ resistor; when the output enable input function has been activated, each SourceMeter channel will not turn on unless the output enable pin is driven to > 2.1 V (nominal current = 2.1 V / 10 kΩ = 210 μA)

²⁵ The Digital I/O feature is not available with the Model 2604B. Only +5 V, GND and INTERLOCK pins are available with the Model 2604B