

# Keysight U1270 Series Handheld Digital Multimeters

# Notices

## Copyright Notice

© Keysight Technologies 2010–2019  
No part of this manual may be reproduced in any form or by any means (including electronic storage and retrieval or translation into a foreign language) without prior agreement and written consent from Keysight Technologies as governed by United States and international copyright laws.

## Manual Part Number

U1271-90020

## Edition

Edition 20, June 3, 2020

## Printed in:

Printed in Malaysia

## Published by:

Keysight Technologies  
Bayan Lepas Free Industrial Zone,  
11900 Penang, Malaysia

## Technology Licenses

The hardware and/or software described in this document are furnished under a license and may be used or copied only in accordance with the terms of such license.

## Declaration of Conformity

Declarations of Conformity for this product and for other Keysight products may be downloaded from the Web. Go to <http://www.keysight.com/go/conformity>. You can then search by product number to find the latest Declaration of Conformity.

## U.S. Government Rights

The Software is “commercial computer software,” as defined by Federal Acquisition Regulation (“FAR”) 2.101. Pursuant to FAR 12.212 and 27.405-3 and Department of Defense FAR Supplement (“DFARS”) 227.7102, the U.S. government acquires commercial computer software under the same terms by which the software is customarily provided to the public. Accordingly, Keysight provides the Software to U.S. government customers under its standard commercial license, which is embodied in its End User License Agreement (EULA), a copy of which can be found at <http://www.keysight.com/find/sweula>. The license set forth in the EULA represents the exclusive authority by which the U.S. government may use, modify, distribute, or disclose the Software. The EULA and the license set forth therein, does not require or permit, among other things, that Keysight: (1) Furnish technical information related to commercial computer software or commercial computer software documentation that is not customarily provided to the public; or (2) Relinquish to, or otherwise provide, the government rights in excess of these rights customarily provided to the public to use, modify, reproduce, release, perform, display, or disclose commercial computer software or commercial computer software documentation. No additional government requirements beyond those set forth in the EULA shall apply, except to the extent that those terms, rights, or licenses are explicitly required from all providers of commercial computer software pursuant to the FAR and the DFARS and are set forth specifically in writing elsewhere in the EULA. Keysight shall be under no obligation to update, revise or otherwise modify the Software. With respect to any technical data as defined by FAR 2.101, pursuant to FAR 12.211 and 27.404.2 and DFARS 227.7102, the U.S. government acquires no greater than Limited Rights as defined in FAR 27.401 or DFAR 227.7103-5 (c), as applicable in any technical data.

## Warranty

THE MATERIAL CONTAINED IN THIS DOCUMENT IS PROVIDED “AS IS,” AND IS SUBJECT TO BEING CHANGED, WITHOUT NOTICE, IN FUTURE EDITIONS. FURTHER, TO THE MAXIMUM EXTENT PERMITTED BY APPLICABLE LAW, KEYSIGHT DISCLAIMS ALL WARRANTIES, EITHER EXPRESS OR IMPLIED, WITH REGARD TO THIS MANUAL AND ANY INFORMATION CONTAINED HEREIN, INCLUDING BUT NOT LIMITED TO THE IMPLIED WARRANTIES OF MERCHANTABILITY AND FITNESS FOR A PARTICULAR PURPOSE. KEYSIGHT SHALL NOT BE LIABLE FOR ERRORS OR FOR INCIDENTAL OR CONSEQUENTIAL DAMAGES IN CONNECTION WITH THE FURNISHING, USE, OR PERFORMANCE OF THIS DOCUMENT OR OF ANY INFORMATION CONTAINED HEREIN. SHOULD KEYSIGHT AND THE USER HAVE A SEPARATE WRITTEN AGREEMENT WITH WARRANTY TERMS COVERING THE MATERIAL IN THIS DOCUMENT THAT CONFLICT WITH THESE TERMS, THE WARRANTY TERMS IN THE SEPARATE AGREEMENT SHALL CONTROL.

## Safety Information

### CAUTION







A CAUTION notice denotes a hazard. It calls attention to an operating procedure, practice, or the like that, if not correctly performed or adhered to, could result in damage to the product or loss of important data. Do not proceed beyond a CAUTION notice until the indicated conditions are fully understood and met.

### WARNING

A WARNING notice denotes a hazard. It calls attention to an operating procedure, practice, or the like that, if not correctly performed or adhered to, could result in personal injury or death. Do not proceed beyond a WARNING notice until the indicated conditions are fully understood and met.

## Safety Symbols

The following symbols on the instrument and in the documentation indicate precautions that must be taken to maintain safe operation of the instrument.

	Direct current (DC)		Caution, risk of electric shock
	Alternating current (AC)		Caution, risk of danger (refer to this manual for specific Warning or Caution information)
	Both direct and alternating current	<b>CAT III 1000 V</b>	Category III 1000 V overvoltage protection
	Earth (ground) terminal	<b>CAT IV 600 V</b>	Category IV 600 V overvoltage protection
	Equipment protected throughout by double insulation or reinforced insulation		

## Safety Considerations

Read the information below before using this multimeter. The descriptions and instructions in this manual apply to the Keysight U1271A, U1272A, U1273A, and U1273AX Handheld Digital Multimeters (hereafter referred to as the multimeter). The U1273A and U1272A models appear in all illustrations.

### CAUTION

- Disconnect circuit power and discharge all high-voltage capacitors before measuring resistance, continuity, diodes, or capacitance.
- Use the proper terminals, function, and range for your measurements.
- This device is for use at altitudes of up to 3000 m.
- Never measure voltage when current measurement is selected.
- Always use the specified battery type. The power for the meter is supplied with four AAA 1.5 V batteries. Observe the correct polarity markings before you insert the batteries to ensure proper insertion of the batteries in the meter.
- You are advised to use low leakage batteries when changing to new batteries. Please remember to remove the batteries when the meter is not in use for a long period of time. Warning on the risk of battery leakage.
- To avoid damage to the instrument from battery leakage:
  - Always remove dead batteries immediately.
  - Always remove the batteries and store them separately if the instrument is not going to be used or is being stored for a long period of time.

### WARNING

- Do not use the multimeter if it is damaged. Before you use the multimeter, inspect the case. Look for cracks or missing plastic. Pay particular attention to the insulation surrounding the connectors.
- Inspect the test leads for damaged insulation or exposed metal. Check the test leads for continuity. Replace damaged test leads before you use the multimeter.
- Do not operate the multimeter around explosive gas, vapor, or wet environments.

**WARNING**

- Do not apply more than the rated voltage (as marked on the multimeter) between terminals, or between the terminal and earth ground. Before use, verify the multimeter's operation by measuring a known voltage.
  - Never use the multimeter in wet conditions or when there is water on the surface. If the multimeter is wet, ensure that the multimeter is dried only by trained personnel.
  - When measuring current, turn off the circuit power before connecting the multimeter in the circuit. Remember to place the multimeter in series with the circuit.
  - Apply caution when working above  $60 V_{DC}$ ,  $30 V_{AC (RMS)}$ , or  $42.4 V_{PEAK}$ . Such voltages pose a shock hazard.
  - Be aware of the presence of hazardous voltage before using the Low Pass Filter (LPF) function for voltage measurement. Voltages measured are usually greater than what are indicated on the multimeter as the voltages with higher frequencies have been filtered through the LPF function.
  - Do not use the  $Z_{LOW}$  (low input impedance) function (U1272A, U1273A, and U1273AX only) to measure voltages in circuits that could be damaged by this function's low input impedance of  $2 k\Omega$  (nominal).
  - When using the probes, keep your fingers behind the finger guards on the probes.
  - Connect the common test lead before you connect the live test lead. When you disconnect the leads, disconnect the live test lead first.
  - Remove the test leads from the multimeter before you open the battery cover. Do not operate the multimeter with the battery cover or portions of the cover removed or loosened. When servicing the multimeter, use only the specified replacement parts.
  - To avoid false readings, which may lead to possible electric shock or personal injury, replace the battery as soon as the low battery indicator appears and flashes.
-

## Measurement Category

The U1270 Series has a safety rating of CAT III, 1000 V and CAT IV, 600 V.

**Measurement CAT I** Measurements performed on circuits not directly connected to the AC mains. Examples are measurements on circuits not derived from the AC mains and specially protected (internal) mains-derived circuits.

**Measurement CAT II** Measurements performed on circuits directly connected to a low-voltage installation. Examples are measurements on household appliances, portable tools, and similar equipment.

**Measurement CAT III** Measurements performed in the building installation. Examples are measurements on distribution boards, circuit-breakers, wiring, including cables, bus-bars, junction boxes, switches, socket outlets in the fixed installation, and equipment for industrial use, and some other equipment including stationary motors with permanent connection to the fixed installation.

**Measurement CAT IV** Measurements performed at the source of the low-voltage installation. Examples are electricity meters and measurements on primary overcurrent protection devices and ripple control units.

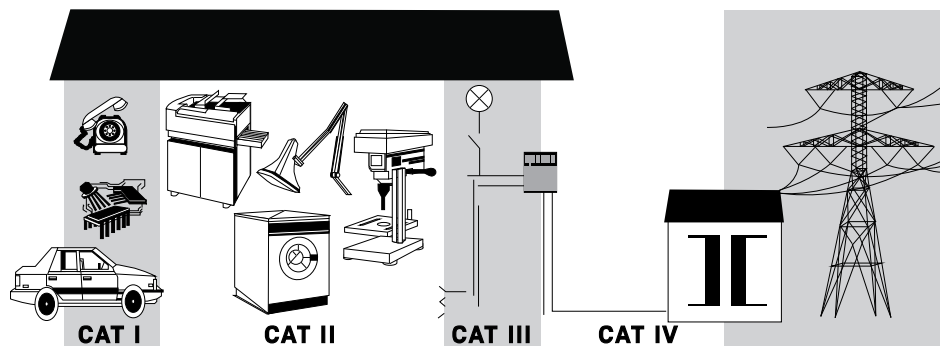

## Environmental Conditions

This instrument is designed for indoor use and in an area with low condensation. The table below shows the general environmental requirements for this instrument.





Environmental condition	Requirement
Temperature	Operating condition <ul style="list-style-type: none"><li>- U1271A/U1272A/U1273A: -20 °C to 55 °C</li><li>- U1273AX: -40 °C to 55 °C (using Lithium batteries)</li></ul>
	Storage condition <ul style="list-style-type: none"><li>- -40 °C to 70 °C</li></ul>
Humidity	Operating condition <ul style="list-style-type: none"><li>- Maximum: 80% RH at 40 °C (non-condensing)</li><li>- Minimum: 50% RH at 40 °C (non-condensing)</li></ul>
	Storage condition <ul style="list-style-type: none"><li>- Up to 95% RH at 40°C (non-condensing)</li></ul>
Altitude	Up to 3000 m
Pollution degree	Pollution degree II

### NOTE

The U1270 Series Handheld Digital Multimeters comply with the following safety and EMC requirements:

- **Safety**
  - EN/IEC 61010-1:2001
  - ANSI/UL 61010-1:2004
  - CAN/CSA-C22.2 No. 61010-1-04
- **EMC**
  - IEC61326-1:2005/EN61326-1:2006
  - Canada: ICES/NMB-001: Issue 4, June 2006
  - Australia/New Zealand: AS/NZS CISPR 11:2004

## Regulatory Markings

 <p>The CE mark is a registered trademark of the European Community. This CE mark shows that the product complies with all the relevant European Legal Directives.</p>	 <p>The RCM mark is a registered trademark of the Spectrum Management Agency of Australia. This signifies compliance with the Australia EMC Framework regulations under the terms of the Radio Communication Act of 1992.</p>
<p><b>ICES/NMB-001</b></p> <p>ICES/NMB-001 indicates that this ISM device complies with the Canadian ICES-001. Cet appareil ISM est conforme a la norme NMB-001 du Canada.</p>	 <p>This instrument complies with the WEEE Directive (2002/96/EC) marking requirement. This affixed product label indicates that you must not discard this electrical or electronic product in domestic household waste.</p>
 <p>The CSA mark is a registered trademark of the Canadian Standards Association.</p>	 <p>This symbol indicates the time period during which no hazardous or toxic substance elements are expected to leak or deteriorate during normal use. Forty years is the expected useful life of the product.</p>



## Waste Electrical and Electronic Equipment (WEEE) Directive 2002/96/EC

This instrument complies with the WEEE Directive (2002/96/EC) marking requirement. This affixed product label indicates that you must not discard this electrical or electronic product in domestic household waste.

### Product category:

With reference to the equipment types in the WEEE directive Annex 1, this instrument is classified as a “Monitoring and Control Instrument” product.

The affixed product label is as shown below.



Do not dispose in domestic household waste.

To return this unwanted instrument, contact your nearest Keysight Service Center, or visit <http://about.keysight.com/en/companyinfo/environment/takeback.shtml> for more information.

## Sales and Technical Support

To contact Keysight for sales and technical support, refer to the support links on the following Keysight websites:

- [www.keysight.com/find/handheldm](http://www.keysight.com/find/handheldm)  
(product-specific information and support, software and documentation updates)
- [www.keysight.com/find/assist](http://www.keysight.com/find/assist)  
(worldwide contact information for repair and service)

THIS PAGE HAS BEEN INTENTIONALLY LEFT BLANK.

# Table of Contents

Safety Symbols	3
Safety Considerations	4
Measurement Category	6
Environmental Conditions	7
Regulatory Markings	8
Waste Electrical and Electronic Equipment (WEEE) Directive 2002/96/EC	9
Product category:	9
Sales and Technical Support	9
<b>1 Calibration Procedures</b>	
Calibration Overview	18
Closed-case calibration	18
Keysight calibration services	18
Calibration interval	19
Adjustment is recommended	19
Recommended Test Equipment	20
Basic Operating Test	21
Backlight test (U1271A/U1272A only)	21
Display test	21
Current terminal input test	22
Calibration Process	24
Test Considerations	25
Performance Verification Tests	26
Calibration Security	35
Unsecuring the Instrument for Calibration	36
To unsecure the instrument from the front panel	36
To change the calibration security code	37
To reset the calibration security code to its factory default	38
Using the Front Panel for Adjustments	40

Adjustment considerations	40
Valid adjustment input values	41
Adjustment procedure	45
Exiting the adjustment mode	46
Calibration Count	47
Calibration Error Codes	48

## 2 Service and Maintenance

Troubleshooting	50
Checking the Fuse	51
Fuse Replacement	55
Returning the Instrument for Service	59
Replaceable Parts	60
To order replaceable parts	60
Types of Service Available	61
Extended service contracts	61
Obtaining Repair Service (Worldwide)	62

## List of Figures

Figure 1-1	U1273A/U1273AX OLED display screen	21
Figure 1-2	U1271A/U1272A LCD screen	22
Figure 1-3	Input warning display (A terminal)	22
Figure 1-4	Input warning display ( $\mu$ A mA terminal)	23
Figure 1-5	Unsecuring the instrument	36
Figure 1-6	Changing the calibration security code	37
Figure 1-7	Resetting the calibration security code	38
Figure 1-8	Reference value display	45
Figure 2-1	Testing Fuse 1	53
Figure 2-2	Testing Fuse 2	54
Figure 2-3	Replacing Fuse 1	56
Figure 2-4	Replacing Fuse 2	57
Figure 2-5	Positions of Fuse 1 and Fuse 2	58

THIS PAGE HAS BEEN INTENTIONALLY LEFT BLANK.

## List of Tables

Table 1-1	Recommended test equipment	20
Table 1-2	Performance verification tests	27
Table 1-3	Adjustment input values	41
Table 1-4	Calibration error codes	48
Table 2-1	Operating checklist	50
Table 2-2	Fuse displayed readings	52

THIS PAGE HAS BEEN INTENTIONALLY LEFT BLANK.



# 1 Calibration Procedures

Calibration Overview	18
Recommended Test Equipment	20
Basic Operating Test	21
Calibration Process	24
Test Considerations	25
Performance Verification Tests	26
Calibration Security	35
Unsecuring the Instrument for Calibration	36
Using the Front Panel for Adjustments	40
Calibration Count	47
Calibration Error Codes	48

This chapter helps you to verify the instrument performance and to make adjustments where necessary.

## Calibration Overview

This manual contains procedures to verify the U1270 Series handheld digital multimeters performance and to perform adjustments (calibration). The performance test procedures allow you to verify that the instrument is operating within its published specifications. The adjustment procedures ensure that the instrument remains within its specifications until the next calibration.

### NOTE

Ensure that you have read the **“Test Considerations”** on page 25 before calibrating the instrument.

---

### Closed-case calibration

The instrument features closed-case electronic calibration. In other words, no internal mechanical adjustments are required. The instrument calculates correction factors based upon the input reference value you set. The new correction factors are stored in the nonvolatile memory until the next calibration adjustment is performed. The nonvolatile EEPROM calibration memory is retained even when the power is switched off.

### Keysight calibration services

When your instrument is due for calibration, contact your local Keysight Service Center to enquire about recalibration services.

## Calibration interval

A 1-year interval is adequate for most applications. Accuracy specifications are warranted only if adjustment is made at regular calibration intervals. Accuracy specifications are not warranted beyond the 1-year calibration interval. Keysight does not recommend extending calibration intervals beyond 2 years for any application.

## Adjustment is recommended

Specifications are only guaranteed within the period stated from the last adjustment. Keysight recommends that re-adjustment should be performed during the calibration process for best performance. This will ensure that the instrument will remain within the specifications for the next calibration interval.

This criterion for the re-adjustment provides the best long-term stability. Performance data are measured during the “**Performance Verification Tests**” but this does not guarantee that the instrument will remain within these limits unless the adjustments are performed.

Refer to the “**Calibration Count**” on page 47 and verify that all the adjustments have been performed.

## Recommended Test Equipment

The test equipment recommended for the performance verification and adjustment procedures are listed below (Table 1-1). If the exact instrument is not available, substitute with another calibration standard of equivalent accuracy.

A suggested alternative method is to use the Keysight 3458A 8½ Digit Digital Multimeter to measure less accurate but stable sources. The output value measured from the source can be entered into the instrument as the target calibration value.

**Table 1-1** Recommended test equipment

Application	Recommended equipment	Recommended accuracy requirements
DC voltage	Fluke 5520A	<20% of the U1270 Series accuracy specification
DC current	Fluke 5520A	<20% of the U1270 Series accuracy specification
Resistance	Fluke 5520A	<20% of the U1270 Series accuracy specification
AC voltage	Fluke 5520A	<20% of the U1270 Series accuracy specification
AC current	Fluke 5520A	<20% of the U1270 Series accuracy specification
Frequency	Fluke 5520A	<20% of the U1270 Series accuracy specification
Capacitance	Fluke 5520A	<20% of the U1270 Series accuracy specification
Duty cycle	Fluke 5520A	<20% of the U1270 Series accuracy specification
Diode	Fluke 5520A	<20% of the U1270 Series accuracy specification
	Fluke 5520A	<20% of the U1270 Series accuracy specification
Temperature	TM Electronics KMPC1MP (K-Type thermocouple extension)	–
Short	Pomona MDP-S	–
$Z_{low}$	Keysight U1252B	–

## Basic Operating Test

The tests listed below are used to test the basic operability of the instrument. Repair is required if the instrument fails any of these tests.

- “Backlight test (U1271A/U1272A only)”
- “Display test”
- “Current terminal input test”

### Backlight test (U1271A/U1272A only)

Press and hold the  key while turning the rotary switch to any other position (OFF to ON). Check that the multimeter’s backlight is turned on. Press any key to exit this mode.

### Display test

Press and hold the  key while turning the rotary switch to any other position (OFF to ON).

#### For U1273A/U1273AX models:

Check that all the OLED pixels are lit. Verify that there are no dead pixels. Press any key to exit this mode.

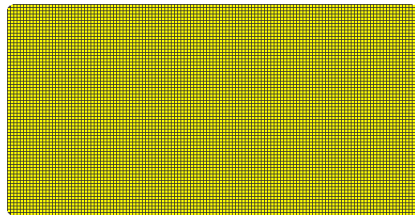

**Figure 1-1** U1273A/U1273AX OLED display screen

**For U1271A/U1272A models:**

Check that all the annunciators are displayed on the LCD screen. Compare the display with the example shown in [Figure 1-2](#). Press any key to exit this mode.

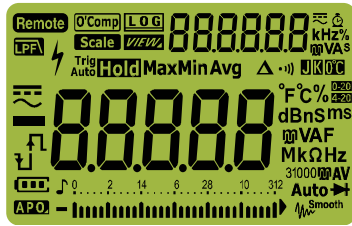

**Figure 1-2** U1271A/U1272A LCD screen

Current terminal input test

This test determines if the input warnings of the current terminals are functioning properly.

**Input warning test (A terminal)**

The multimeter sounds a continuous alert beep when the test lead is inserted into the **A** terminal but the rotary switch is not set to the  $\tilde{mA}$  function.

The multimeter displays an input warning error ([Figure 1-3](#)).

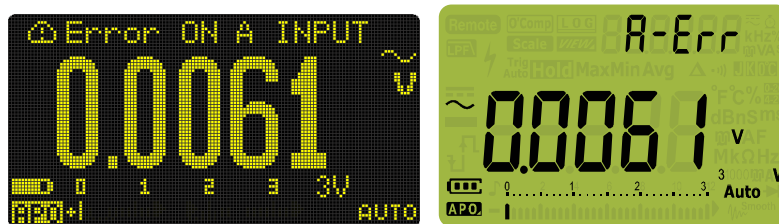

**Figure 1-3** Input warning display (A terminal)

The alert beep tone will continue to beep until the test lead is removed from the **A** terminal or until the rotary switch is set to the  $\tilde{\mu}\text{A}$  function.

**NOTE**

Before conducting this test, ensure that the beep function is not disabled in the multimeter's setup.

**Input warning test ( $\mu\text{A}$  mA terminal)**

The multimeter sounds a continuous alert beep when the test lead is inserted into the  **$\mu\text{A}$  mA** terminal but the rotary switch is not set to the  $\tilde{\mu}\text{A}$  or  $\tilde{\text{mA}}$  function.

The multimeter displays an input warning error (Figure 1-4).

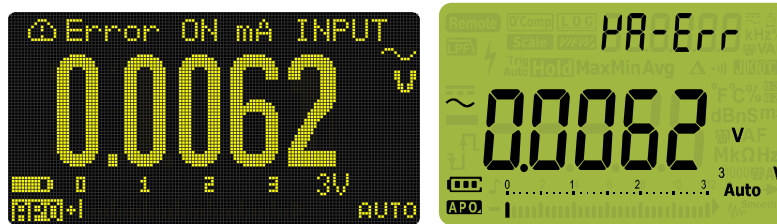

**Figure 1-4** Input warning display ( $\mu\text{A}$  mA terminal)

The alert beep tone will continue to beep until the test lead is removed from the  **$\mu\text{A}$  mA** terminal or until the rotary switch is set to the  $\tilde{\mu}\text{A}$  or  $\tilde{\text{mA}}$  function.

**NOTE**

Before conducting this test, ensure that the beep function is not disabled in the multimeter's setup.

## Calibration Process

- 1 Prior to performing the verification tests, see the “[Test Considerations](#)” on page 25.
- 2 Perform the verification tests to characterize the instrument; see “[Performance Verification Tests](#)” on page 26.
- 3 Unsecure the instrument for calibration; see “[Calibration Security](#)” on page 35.
- 4 Prior to performing the adjustments, see the “[Adjustment considerations](#)” on page 40.
- 5 Perform the adjustment procedure; see “[Adjustment procedure](#)” on page 45.
- 6 Secure the instrument against unauthorized calibration; see “[Exiting the adjustment mode](#)” on page 46. Ensure that the instrument has quit the adjustment mode and is turned off.
- 7 Record the new security code and calibration count in the instrument's maintenance records.



## Test Considerations

For optimum performance, all procedures should comply with the following recommendations:

- The performance verification test or adjustment should be performed under laboratory conditions where the ambient temperature can be controlled.
- The instrument should be put under the laboratory environment for at least 1 hour.
- Ensure that the calibration ambient temperature is stable and is between 18 °C and 28 °C. Ideally the calibration should be performed at 23 °C ± 1 °C.
- Ensure that the ambient relative humidity is less than 80%.
- Allow a warm-up period of 3 minutes.
- Use a shielded twisted pair of PTFE-insulated cables to reduce settling and noise errors. Keep the input cables as short as possible. Long test leads can also act as antennas which may pick up AC signals.
- Connect the input cable shields to earth ground.

## Performance Verification Tests

Use the performance verification tests to verify the measurement performance of the instrument. The performance verification tests use the instrument's specifications listed in the *U1271A/U1272A User's Guide* and the *U1273A/U1273AX User's Guide* (available for download at [www.keysight.com/find/hhTechLib](http://www.keysight.com/find/hhTechLib)).

The performance verification tests are recommended as acceptance tests when you first receive the instrument. The acceptance test results should be compared against the 1 year test limits. After acceptance, you should repeat the performance verification tests at every calibration interval.

If the instrument fails the performance verification tests, adjustment or repair is required.

**NOTE**

Ensure that you have read the **“Test Considerations”** on page 25 before running the performance verification tests.

---

**Table 1-2** Performance verification tests







Step	Test function	Range	5520 output	Error from nominal 1 year	
				U1271A	U1272A/ U1273A/U1273AX
1 <sup>[a]</sup>	<b>Qik-V</b> Turn the rotary switch to the $\tilde{\approx}_{\text{Qik-V}}$ position.	1000 V	1000 V	±20 V	-
			1000 V, 70 Hz	±250 V	-
	<b>Z<sub>LOW</sub></b> Turn the rotary switch to the $\tilde{\approx}_{\text{V}}^{\text{LOW}}$ position.	1000 V	3 V	-	±2.0 V
<b>NOTE: First connect the COM and <math>\Omega</math> terminals of the U1252B (or equivalent) to the COM and V terminals of the U1272A/U1273A/U1273AX, then turn the U1272A/U1273A/U1273AX rotary switch to the <math>\tilde{\approx}_{\text{V}}^{\text{LOW}}</math> position before proceeding with the following Z<sub>LOW</sub> functional test.</b>					
<b>U1252B input</b>					
	<b>Z<sub>LOW</sub></b> Turn the rotary switch to the $\tilde{\approx}_{\text{V}}^{\text{LOW}}$ position.	1000 V	2 k $\Omega$ (nominal)	-	±1 k $\Omega$

[a] Functional test only.



**Table 1-2** Performance verification tests (continued)

Step	Test function	Range	5520 output	Error from nominal 1 year	
				U1271A	U1272A/ U1273A/U1273AX
2	ACV Turn the rotary switch to the  position.	3 V	3 V, 20 Hz	-	±0.0325 V
			3 V, 45 Hz	±0.0230 V	±0.0200 V
			3 V, 65 Hz	±0.0230 V	±0.0200 V
			3 V, 1 kHz	±0.0325 V	±0.0325 V
			3 V, 5 kHz	±0.0625 V	±0.0475 V
			3 V, 20 kHz	±0.0640 V	±0.0640 V
			2.7 V, 100 kHz	-	±0.0985 V
		30 V	30 V, 20 Hz	-	±0.325 V
			30 V, 45 Hz	±0.230 V	±0.200 V
			30 V, 65 Hz	±0.230 V	±0.200 V
			30 V, 1 kHz	±0.325 V	±0.325 V
			30 V, 5 kHz	±0.0625 V	±0.475 V
			30 V, 20 kHz	±0.640 V	±0.640 V
			27 V, 100 kHz	-	±0.985 V
		300 V	300 V, 45 Hz	±2.30 V	±2.00 V
			300 V, 65 Hz	±2.30 V	±2.00 V
			300 V, 1 kHz	±3.25 V	±3.25 V
			300 V, 5 kHz	±6.25 V	±4.75 V
			270 V, 20 kHz	-	±5.80 V
		1000 V	1000 V, 45 Hz	±9.0 V	±8.0 V
			1000 V, 65 Hz	±9.0 V	±8.0 V
1000 V, 1 kHz	±12.5 V		±12.5 V		
1000 V, 5 kHz	-		±17.5 V		







**Table 1-2** Performance verification tests (continued)

Step	Test function	Range	5520 output	Error from nominal 1 year	
				U1271A	U1272A/ U1273A/U1273AX
	<b>LPF</b> While the rotary switch is in the  position, press the  key once.	3 V	3 V, 20 Hz	-	±0.0325 V
			3 V, 45 Hz	±0.0230 V	±0.0200 V
			3 V, 65 Hz	±0.0230 V	±0.0200 V
			2.7 V, 430 Hz	±0.1375 V	±0.1375 V
<b>3</b>	<b>Frequency</b> While the rotary switch is in the  position, press the  key once.	9.9999 kHz	1.0000 kHz, 0.096 V	±0.0005 kHz	±0.0005 kHz
<b>4</b>	<b>Duty cycle</b> While the rotary switch is in the  position, press the  key twice.	99.99%	50%, 100 Hz, 3 Vpp square wave	±0.3%	±0.3%
<b>5</b>	<b>ACmV</b> Turn the rotary switch to the  position.	30 mV	30 mV, 20 Hz	-	±0.235 mV
			30 mV, 45 Hz	-	±0.200 mV
			30 mV, 65 Hz	-	±0.200 mV
			30 mV, 1 kHz	-	±0.235 mV
			30 mV, 5 kHz	-	±0.325 mV
			30 mV, 20 kHz	-	±0.340 mV
			30 mV, 100 kHz	-	±1.090 mV
		300 mV	300 mV, 20 Hz	-	±2.35 mV
			300 mV, 45 Hz	±2.30 mV	±2.00 mV
			300 mV, 65 Hz	±2.30 mV	±2.00 mV
			300 mV, 1 kHz	±3.25 mV	±2.35 mV
			300 mV, 5 kHz	±6.25 mV	±3.25 mV
			300 mV, 20 kHz	±6.40 mV	±3.40 mV
300 mV, 100 kHz	-	±10.90 mV			





**Table 1-2** Performance verification tests (continued)

Step	Test function	Range	5520 output	Error from nominal 1 year		
				U1271A	U1272A/ U1273A/U1273AX	
6	<b>DCV</b> Turn the rotary switch to the  /  position.	3 V	3 V	±0.0020 V	±0.0020 V	
		30 V	30 V	±0.017 V	±0.017 V	
		300 V	300 V	±0.17 V	±0.17 V	
		1000 V	1000 V	±0.7 V	±0.7 V	
7	<b>AC+DCV</b> Turn the rotary switch to the  position, and press the  key twice.	3 V	3 V, 20 Hz	-	±0.0360 V	
			3 V, 45 Hz	-	±0.0235 V	
			3 V, 65 Hz	-	±0.0235 V	
			3 V, 1 kHz	-	±0.0360 V	
			3 V, 5 kHz	-	±0.0510 V	
			3 V, 20 kHz	-	±0.0675 V	
			2.7 V, 100 kHz	-	±0.1017 V	
			30 V	30 V, 20 Hz	-	±0.360 V
		30 V	30 V, 45 Hz	-	±0.235 V	
			30 V, 65 Hz	-	±0.235 V	
			30 V, 1 kHz	-	±0.360 V	
			30 V, 5 kHz	-	±0.510 V	
			30 V, 20 kHz	-	±0.675 V	
			27 V, 100 kHz	-	±1.017 V	
			300 V	300 V, 45 Hz	-	±2.35 V
				300 V, 65 Hz	-	±2.35 V
300 V, 1 kHz	-	±3.60 V				
300 V, 5 kHz	-	±5.10 V				
		270 V, 20 kHz	-	±6.12 V		

**Table 1-2** Performance verification tests (continued)







Step	Test function	Range	5520 output	Error from nominal 1 year	
				U1271A	U1272A/ U1273A/U1273AX
	<b>AC+DCV</b> Turn the rotary switch to the  position, and press the  key twice.	1000 V	1000 V, 45 Hz	-	±9.5 V
			1000 V, 65 Hz	-	±9.5 V
			1000 V, 1 kHz	-	±14.0 V
			1000 V, 5 kHz	-	±19.0 V
8	<b>DCmV</b> <sup>[b]</sup> Turn the rotary switch to the  position.	30 mV	30 mV	-	±0.035 mV
			-30 mV	-	±0.035 mV
		300 mV	300 mV	±0.20 mV	±0.20 mV
			-300 mV	±0.20 mV	±0.20 mV
[b] The accuracy is specified after the Null function is used to subtract the thermal effect (by shorting the test leads) before measuring the signal.					
9	<b>AC+DCmV</b> Turn the rotary switch to the  position, and press the  key twice.	30 mV	30 mV, 20 Hz	-	±0.285 mV
			30 mV, 45 Hz	-	±0.250 mV
			30 mV, 65 Hz	-	±0.250 mV
			30 mV, 1 kHz	-	±0.285 mV
			30 mV, 5 kHz	-	±0.375 mV
			30 mV, 20 kHz	-	±0.390 mV
			30 mV, 100 kHz	-	±1.140 mV
	<b>AC+DCmV</b> Turn the rotary switch to the  position, and press the  key twice.	300 mV	300 mV, 20 Hz	-	±2.70 mV
			300 mV, 45 Hz	-	±2.35 mV
			300 mV, 65 Hz	-	±2.35 mV
			300 mV, 1 kHz	-	±2.70 mV
			300 mV, 5 kHz	-	±3.60 mV
			300 mV, 20 kHz	-	±3.75 mV
			300 mV, 100 kHz	-	±11.25 mV

**Table 1-2** Performance verification tests (continued)





Step	Test function	Range	5520 output	Error from nominal 1 year	
				U1271A	U1272A/ U1273A/U1273AX
10	<b>Resistance</b> Turn the rotary switch to the  position.	30 Ω <sup>[c][e]</sup>	30 Ω	-	±0.070 Ω
		300 Ω <sup>[c][e]</sup>	300 Ω	±0.65 Ω	±0.65 Ω
		3 kΩ <sup>[c][e]</sup>	3 kΩ	±0.0065 kΩ	±0.0065 kΩ
		30 kΩ <sup>[e]</sup>	30 kΩ	±0.065 kΩ	±0.065 kΩ
		300 kΩ	300 kΩ	±0.65 kΩ	±0.65 kΩ
		3 MΩ	3 MΩ	±0.0185 MΩ	±0.0185 MΩ
		30 MΩ <sup>[d]</sup>	30 MΩ	±0.365 MΩ	±0.365 MΩ
		100 MΩ <sup>[d]</sup>	100 MΩ	±2.10 MΩ	-
		300 MΩ <sup>[d]</sup>	120 MΩ	-	±9.70 MΩ
<p>[c] The accuracy of the 30 Ω to 3 kΩ range is specified after the Null function is used to subtract the test lead resistance and thermal effect (by shorting the test leads). Apply a 0 Ω calibrator output and allow the multimeter to settle before pressing the  key.</p> <p>[d] The RH is specified for &lt;60%.</p> <p>[e] With a 2-wire connection and compensation enabled at calibrator.</p>					
11	<b>Diode</b> Turn the rotary switch to the  or  position.	3 V	3 V	0.0155 V	0.0155 V
12	<b>Capacitance</b> <sup>[f]</sup> Turn the rotary switch to the  position.	10 nF	10 nF	±0.105 nF	±0.105 nF
		100 nF	100 nF	±1.02 nF	±1.02 nF
		1000 nF	1000 nF	±10.2 nF	±10.2 nF
		10 μF	10 μF	±0.102 μF	±0.102 μF
		100 μF	100 μF	±1.02 μF	±1.02 μF
		1000 μF	1000 μF	±10.2 μF	±10.2 μF
		10 mF	10 mF	±0.102 mF	±0.102 mF
<p>[f] The accuracy for all ranges is specified based on a film capacitor or better, and after the Null function is used to subtract the residual values (by opening the test leads).</p>					



**Table 1-2** Performance verification tests (continued)

Step	Test function	Range	5520 output	Error from nominal 1 year	
				U1271A	U1272A/ U1273A/U1273AX
13	<b>Temperature</b> <sup>[g]</sup> While the rotary switch is in the  position, press the  key once.	-200 °C to 1372 °C	-200 °C	± 3.0 °C	± 3.0 °C
			0 °C	± 1.0 °C	± 1.0 °C
			1372 °C	± 14.7 °C	± 14.7 °C
[g]	Set both calibrator and multimeter to internal reference.				
	To perform the measurement, connect the K-type thermocouple extension (with miniature thermocouple connector on both ends) between the calibrator's TC output and multimeter via a TC-to-banana adapter.				
	Allow at least 1 hour for the multimeter to stabilize before measurements are taken.				
	The error limit does not include the error contributed by the thermocouple extension. To eliminate the thermocouple error, compensation of the calibrator output through a reference thermometer is recommended.				
	Ensure that the ambient temperature is stable within ± 1°C. Make sure that the multimeter is placed in a controlled environment for at least 1 hour. Keep the multimeter away from any ventilation exit. Do not touch the thermocouple test lead after connecting it to the calibrator. Allow the connection to stabilize for at least another 15 minutes before performing the measurement.				
14	<b>DCμA</b> Turn the rotary switch to the  position.	300 μA 3000 μA	300 μA	±0.65 μA	±0.65 μA
			3000 μA	±6.5 μA	±6.5 μA
15	<b>ACμA</b> While the rotary switch is in the  position, press the  key once.	300 μA	300 μA, 20 Hz	-	±2.95 μA
			300 μA, 45 Hz	±2.95 μA	±2.05 μA
			300 μA, 65 Hz	±2.95 μA	±2.05 μA
			300 μA, 1 kHz	±2.95 μA	±2.95 μA
		3000 μA	3000 μA, 20 Hz	-	±29.5 μA
			3000 μA, 45 Hz	±29.5 μA	±20.5 μA
			3000 μA, 65 Hz	±29.5 μA	±20.5 μA
			3000 μA, 1 kHz	±29.5 μA	±29.5 μA
16	<b>DCmA</b> Turn the rotary switch to the  position.	30 mA 300 mA	30 mA	±0.065 mA	±0.065 mA
			300 mA	±0.65 mA	±0.65 mA

**Table 1-2** Performance verification tests (continued)

Step	Test function	Range	5520 output	Error from nominal 1 year	
				U1271A	U1272A/ U1273A/U1273AX
17	<b>ACmA</b> While the rotary switch is in the  position, press the  key once.	30 mA	30 mA, 20 Hz	-	±0.295 mA
			30 mA, 45 Hz	±0.295 mA	±0.205 mA
			30 mA, 65 Hz	±0.295 mA	±0.205 mA
			30 mA, 1 kHz	±0.295 mA	±0.295 mA
		300 mA	300 mA, 20 Hz	-	±2.95 mA
			300 mA, 45 Hz	±2.95 mA	±2.05 mA
			300 mA, 65 Hz	±2.95 mA	±2.05 mA
			300 mA, 1 kHz	±2.95 mA	±2.95 mA
18	<b>DCA<sup>[h]</sup></b> Turn the rotary switch to the  position.	3 A	3 A	±0.0100 A	±0.0100 A
		10 A	10 A	±0.04 A	±0.04 A
[h] <b>CAUTION:</b> Connect the calibrator to the multimeter's <b>A</b> and <b>COM</b> terminals before applying the 3 A and 10 A input.					
19	<b>ACA</b> While the rotary switch is in the  position, press the  key once.	3 A	3 A, 45 Hz	±0.0325 A	±0.0265 A
			3 A, 65 Hz	±0.0325 A	±0.0265 A
			3 A, 1 kHz	±0.0325 A	±0.0325 A
		10 A	10 A, 45 Hz	±0.125 A	±0.105 A
			10 A, 65 Hz	±0.125 A	±0.105 A
			10 A, 1 kHz	±0.125 A	±0.125 A

## Calibration Security

The calibration security code prevents accidental or unauthorized adjustments to the instrument. When you first receive your instrument, it is secured. Before you can adjust the instrument, you must unsecure it by entering the correct security code (see [“Unsecuring the Instrument for Calibration”](#) on page 36).

**NOTE**

**The security code can only be changed after the instrument has been unsecured. You can unsecure the instrument from its front panel.**

---

The security code is set to “1234” when the instrument is shipped from the factory. The security code is stored in nonvolatile memory, and does not change when power has been turned off.

The security code may contain up to four numeric characters.

## Unsecuring the Instrument for Calibration



Before you can adjust the instrument, you must unsecure it by entering the correct security code.

The default security code is set to 1234.

### NOTE

If you forget your security code, see **“To reset the calibration security code to its factory default”** on page 38.



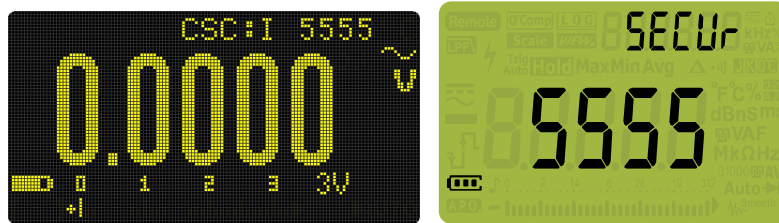

To unsecure the instrument from the front panel

- 1 Power-on the instrument and press the  and  keys simultaneously for more than 1 second.

The calibration security code entry is shown on the display.



**Figure 1-5** Unsecuring the instrument

- 2 Key in the default security code if you are unsecuring your instrument for the first time.
  - Press  or  to move the cursor to the right or to the left.
  - Press  or  to increment or decrement the digit.
- 3 Press  when you are done.

If the correct security code is entered, **PASS** is shown briefly, after which the instrument will enter the adjustment mode.



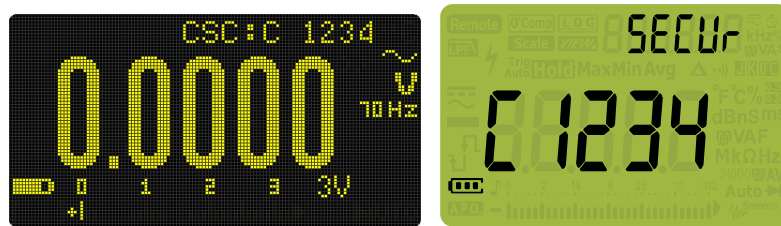

If the incorrect security code is entered, an error code will appear briefly, after which the instrument will prompt you for the security code again.

## To change the calibration security code

- 1 After the instrument has been unsecured, press  for more than 1 second.
- 2 The factory default calibration security code “1234” is shown on the display if you are changing the calibration security code for the first time.



**Figure 1-6** Changing the calibration security code

- 3 Set your new calibration security code.
  - Press  or  to move the cursor to the right or to the left.
  - Press  or  to increment or decrement the digit.
- 4 Press  to save the new calibration security code.





If the new calibration security code has been successfully stored, the display will show **PASS**. Record down your new calibration security code and store it in a safe location.

## To reset the calibration security code to its factory default

If you have forgotten the correct calibration security code, you may follow the steps below to reset the calibration security code to the factory default code (1234).



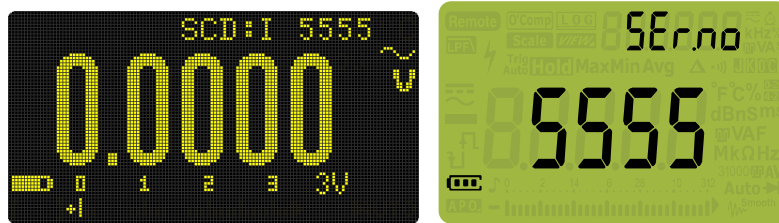

### NOTE

If you do not have a record (or have lost the record) of the security code, first try the factory default code, “1234”.

- 1 Before you begin, note down the last four digits of the instrument's serial number (located at the bottom of the rear panel).
- 2 Power-on the instrument and press the  and  keys simultaneously for more than 1 second.  
The calibration security code entry is shown on the display.
- 3 Press  (for U1273A/U1273AX) or  (for U1271A/U1272A) for more than 1 second.



**Figure 1-7** Resetting the calibration security code

- 4 Set the code to the same as the last four digits of the instrument's serial number.
  - Press  or  to move the cursor to the right or to the left.
  - Press  or  to increment or decrement the digit.
- 5 Press  to confirm the entry.

If the four digits entered are correct, the display will show **PASS**. The calibration security code is now set to its factory default code, 1234.

If the incorrect security code is entered, an error code will appear briefly, after which the instrument will prompt you for the security code again.

If you want to enter a new security code, see [“To change the calibration security code”](#) on page 37. Ensure that you record down the new security code.

## Using the Front Panel for Adjustments

This section describes the procedures to perform adjustments from the front panel.

To unsecure the instrument, see [“To unsecure the instrument from the front panel”](#) on page 36. Once unsecured, the reference value will be indicated on the display.

### Adjustment considerations

#### NOTE

After each adjustment, the display shows **PASS**. If the calibration fails, the instrument sounds a beep, and an error number is shown on the display. Calibration error messages are described in [“Calibration Error Codes”](#) on page 48.

- 1 Allow the instrument to warm up and stabilize for 3 minutes before performing the adjustments.
- 2 Ensure that during the adjustments, the low battery indicator does not appear. If the low battery indicator appears, replace the batteries as soon as possible to avoid false readings.
- 3 Consider the thermal effects as you are connecting the test leads to the calibrator and multimeter. It is recommended to wait for 1 minute before you begin the calibration after connecting the test leads.
- 4 Before proceeding with the ambient temperature adjustment, be sure to turn on the multimeter for at least 1 hour with the K-type thermocouple connected.

#### CAUTION

Never turn off the multimeter during an adjustment. This may delete the calibration memory for the present function.



## Valid adjustment input values

Adjustment can be accomplished using the following input values below.

**Table 1-3** Adjustment input values

Test function	Step	Reference value	Valid reference input
DCmV	SHORT	SHORT	SHORT V/COM terminals
	30 mV	30.000 mV	0.9 to 1.1 × Reference value
	300 mV	300.00 mV	0.9 to 1.1 × Reference value
ACmV	30 mV	3.000 mV (70 Hz)	0.9 to 1.1 × Reference value
		30.000 mV (70 Hz)	0.9 to 1.1 × Reference value
		30.000 mV (30 kHz)	0.9 to 1.1 × Reference value
	300 mV	30.00 mV (70 Hz)	0.9 to 1.1 × Reference value
		300.00 mV (70 Hz)	0.9 to 1.1 × Reference value
		300.00 mV (30 kHz)	0.9 to 1.1 × Reference value
DCV	SHORT	SHORT	SHORT V/COM terminals
	3 V	3.0000 V	0.9 to 1.1 × Reference value
	30 V	30.000 V	0.9 to 1.1 × Reference value
	300 V	300.00 V	0.9 to 1.1 × Reference value
	1000 V	1000.0 V	0.9 to 1.1 × Reference value

**Table 1-3** Adjustment input values (continued)

Test function	Step	Reference value	Valid reference input
ACV	3 V	0.3000 V (70 Hz)	0.9 to 1.1 × Reference value
		3.0000 V (70 Hz)	0.9 to 1.1 × Reference value
		3.0000 V(3 kHz)	0.9 to 1.1 × Reference value
	30 V	3.000 V (70 Hz)	0.9 to 1.1 × Reference value
		30.000 V (70 Hz)	0.9 to 1.1 × Reference value
		30.000 V(3 kHz)	0.9 to 1.1 × Reference value
	300 V	30.00 V (70 Hz)	0.9 to 1.1 × Reference value
		300.00 V (70 Hz)	0.9 to 1.1 × Reference value
		300.00 V (3 kHz)	0.9 to 1.1 × Reference value
	1000 V	30.0 V (70 Hz)	0.9 to 1.1 × Reference value
		300.0 V (70 Hz)	0.9 to 1.1 × Reference value
		300.0 V (3 kHz)	0.9 to 1.1 × Reference value
DC $\mu$ A	OPEN	OPEN	OPEN terminals
	300 $\mu$ A	300.00 $\mu$ A	0.9 to 1.1× Reference value
	3000 $\mu$ A	3000.0 $\mu$ A	0.9 to 1.1 × Reference value
AC $\mu$ A	300 $\mu$ A	030.00 $\mu$ A (70 Hz)	0.9 to 1.1 × Reference value
		300.00 $\mu$ A (70 Hz)	0.9 to 1.1 × Reference value
	3000 $\mu$ A	300.0 $\mu$ A (70 Hz)	0.9 to 1.1 × Reference value
		3000.0 $\mu$ A (70 Hz)	0.9 to 1.1 × Reference value
DCmA/DCA	OPEN	OPEN	OPEN terminals
	30 mA	30.000 mA	0.9 to 1.1 × Reference value
	300 mA	300.00 mA	0.9 to 1.1 × Reference value
	3 A	3.0000 A	0.9 to 1.1 × Reference value
	10 A	10.000 A	0.9 to 1.1 × Reference value

**Table 1-3** Adjustment input values (continued)

Test function	Step	Reference value	Valid reference input	
ACmA/ACA	30 mA	03.000 mA (70 Hz)	0.9 to 1.1 × Reference value	
		30.000 mA (70 Hz)	0.9 to 1.1 × Reference value	
	300 mA	030.00 mA (70 Hz)	0.9 to 1.1 × Reference value	
		300.00 mA (70 Hz)	0.9 to 1.1 × Reference value	
	3 A	0.3000 A (70 Hz)	0.9 to 1.1 × Reference value	
		3.0000 A (70 Hz)	0.9 to 1.1 × Reference value	
	10 A	3.0000 A (70 Hz)	0.9 to 1.1 × Reference value	
		10.000 A (70 Hz)	0.9 to 1.1 × Reference value	
	Capacitance	OPEN	OPEN	With cables connected to CAP/COM terminals
		10 nF	04.000 nF	0.9 to 1.1 × Reference value
10.000 nF			0.9 to 1.1 × Reference value	
100 nF		010.00 nF	0.9 to 1.1 × Reference value	
		100.00 nF	0.9 to 1.1 × Reference value	
1000 nF		0100.0 nF	0.9 to 1.1 × Reference value	
		1000.0 nF	0.9 to 1.1 × Reference value	
10 μF		10.000 μF	0.9 to 1.1 × Reference value	
100 μF		100.00 μF	0.9 to 1.1 × Reference value	
1000 μF		1000.0 μF	0.9 to 1.1 × Reference value	
10 mF		10.000 mF	0.9 to 1.1 × Reference value	
OPEN		OPEN	OPEN terminals (no cables connected to CAP/COM terminals) <sup>[a]</sup>	

**Table 1-3** Adjustment input values (continued)

Test function	Step	Reference value	Valid reference input
Resistance	SHORT	0 $\Omega$ <sup>[b]</sup>	0 $\Omega$ from calibrator
	30 M $\Omega$	OPEN	OPEN terminals
		10.000 M $\Omega$	0.9 to 1.1 $\times$ Reference value
	3 M $\Omega$	3.0000 M $\Omega$	0.9 to 1.1 $\times$ Reference value
	300 k $\Omega$	300.00 k $\Omega$	0.9 to 1.1 $\times$ Reference value
	30 k $\Omega$	30.000 k $\Omega$ <sup>[b]</sup>	0.9 to 1.1 $\times$ Reference value
	3 k $\Omega$	3.0000 k $\Omega$ <sup>[b]</sup>	0.9 to 1.1 $\times$ Reference value
	300 $\Omega$	300.00 $\Omega$ <sup>[b]</sup>	0.9 to 1.1 $\times$ Reference value
	30 $\Omega$	30.000 $\Omega$ <sup>[b]</sup>	0.9 to 1.1 $\times$ Reference value
		SHORT	SHORT <sup>[c]</sup>
Temperature	K type	0000.0 $^{\circ}$ C	0 $^{\circ}$ C with ambient compensation required
<p><b>Note:</b> Ensure the multimeter is turned on and stabilized for at least 60 minutes with the K-type thermocouple connected between the multimeter and the calibrator output terminal.</p> <ul style="list-style-type: none"> <li>- Set the 5520A to internal reference.</li> <li>- Prior to performing adjustment, connect one end of the K-type thermocouple (with miniature TC connector on both ends) to the 5520A TC output, and the other end to a precision thermometer to verify that the source outputs the desired value. Adjust the source accordingly if necessary.</li> <li>- To perform the adjustment, connect one end of the K-type thermocouple (with miniature TC connector on both ends) to the 5520A TC output, and the other end to the multimeter via a TC-to-banana adapter. Allow at least 1 hour for the multimeter to stabilize.</li> </ul>			
Diode	SHORT	SHORT	SHORT V/COM terminals
	3 V	2.0000 V	0.9 to 1.1 $\times$ Reference value

[a] After capacitance calibration is completed, calibrate the OPEN item again by removing all cable connections from the Device-Under-Test (DUT).

[b] With a 2-wire connection and compensation enabled at the calibrator.

[c] After resistance calibration is completed, calibrate the SHORT item again by inserting a short bar between the  $\Omega$ /COM terminals.

## Adjustment procedure

**NOTE**

Review the “**Test Considerations**” and “**Adjustment considerations**” before beginning the adjustment procedures.

- 1 Turn the rotary switch to the respective test function position as shown in the adjustment input values table (Table 1-3).
- 2 Unsecure the instrument to enter the adjustment mode. (See “**Unsecuring the Instrument for Calibration**” on page 36).

**NOTE**

While in the adjustment mode, press  and  simultaneously to exit the adjustment mode.

- 3 The reference value of the calibration item will be shown on the display.

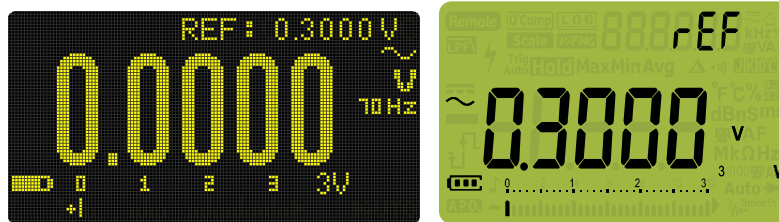

**Figure 1-8** Reference value display

- 4 Configure each calibration item.
- 5 Use the arrow keys to select the calibration range.
- 6 Apply the input signal shown in the **Reference value** column of Table 1-3. The analog bar graph displays the input reading. There is no bar graph display for temperature adjustment.

**NOTE**

You are highly recommended to complete the adjustments in the same order as shown in **Table 1-3**.

---

- 7 Use the arrow keys to enter the actual applied input values.
- 8 Press  to start the adjustment. **CAL** is shown on the display to indicate that the calibration is in progress.
- 9 Upon completion of each adjustment value, the display will show **PASS**. If the adjustment fails, the instrument will sound a long beep and the calibration error number is shown on the display.



**NOTE**

If the adjustment fails, check the input value, range, function, and entered adjustment value before repeating the adjustment steps.

---

- 10 Turn the rotary switch to the next function according to the **Test function** column shown in **Table 1-3**. Repeat **step 3** to **step 8** for each adjustment point shown in the adjustment table.
- 11 Verify the adjustments using the “**Performance Verification Tests**” on page 26.

### Exiting the adjustment mode

- 1 Remove all the shorting plugs and connectors from the instrument.
- 2 Record the new Calibration Count.
- 3 Press  and  simultaneously to exit the Adjustment Mode.
- 4 Cycle the instrument's power. The instrument will then be secured.

## Calibration Count



You can query the instrument to determine how many adjustments have been performed.

### NOTE

The instrument has been calibrated before it left the factory. You are recommended to record the initial value of the calibration count once you receive the instrument.

---

The count value increases by one for each calibration point, from 0000 up to the maximum of 19999. After the maximum count, the calibration count will reset to 0. The calibration count can be read from the front panel after the instrument has been unsecured.

- 1 In adjustment mode, press  to view the calibration count.
- 2 Take note of the calibration count to keep track of the number of calibrations that have been performed.
- 3 Press  again to exit the calibration count mode.

## Calibration Error Codes

The following errors indicate failures that may occur during a calibration.

**Table 1-4** Calibration error codes

Code	Descriptions
Er002	Calibration error: secure code invalid
Er003	Calibration error: serial number code invalid
Er004	Calibration error: calibration aborted
Er005	Calibration error: value out of range
Er006	Calibration error: signal measurement out of range
Er007	Calibration error: frequency out of range
Er008	EEPROM write failure



## 2 Service and Maintenance

Troubleshooting	50
Checking the Fuse	51
Fuse Replacement	55
Returning the Instrument for Service	59
Replaceable Parts	60
Types of Service Available	61
Obtaining Repair Service (Worldwide)	62

This chapter will help you troubleshoot a failing instrument. It also describes how to obtain repair services and lists the replaceable assemblies.

## Troubleshooting

### WARNING

To avoid electrical shock, do not perform any servicing unless you are qualified to do so.

### CAUTION

Any repair or service which is not covered in this manual should only be performed by qualified personnel.

If the instrument fails to operate, check the batteries and the test leads. Replace them if necessary. If the instrument still does not function, check the operating procedures in this manual. When servicing, use only the specified replacement parts.

The table below will assist you in identifying some basic malfunctions.

**Table 2-1** Operating checklist



Mal function	Identification
No display when powered ON using the rotary switch	? Verify the batteries health and replace batteries as necessary.
No beeper tone	? Verify that the beeper is enabled in the multimeter's setup mode.
Failed on current measurement	? Verify the fuses health and replace the fuses as necessary.
Failed on remote control	? Verify the optical side of the IR-USB cable connected to the multimeter – the Keysight logo should be facing up.
	? Verify the baud rate, data bit, and parity settings in the multimeter's setup mode. (Default values are 9600, 8, and none.)
	? Verify that the driver for the IR-USB interface is installed.

## Checking the Fuse

It is recommended that you check the fuse(s) of the multimeter before using it. Follow the instructions below to test the fuses inside the multimeter.

### NOTE

Refer to [Figure 2-5](#) for the respective positions of Fuse 1 (10 × 35 mm, 440 mA/1000 V fast-acting fuse) and Fuse 2 (10 × 38 mm, 11 A/1000 V fast-acting fuse).

- 1 Turn the rotary switch to the  or  position and connect the red test lead to the  $\Omega$  input terminal.
- 2 To test Fuse 1, place the tip of the test probe on the top half of the  **$\mu\text{A mA}$**  input terminal. Ensure that the probe tip touches the metal inside the  **$\mu\text{A mA}$**  input terminal, as shown in [Figure 2-1](#).
- 3 To test Fuse 2, place and touch the tip of the test probe on the left half of the **A** input terminal. Ensure that the probe tip touches the metal inside the **A** input terminal, as shown in [Figure 2-2](#).
- 4 Observe the reading on the instrument's display. Refer to [Table 2-2](#) below for the possible readings that could appear. Replace the fuse when **OL** is displayed.

**Table 2-2** Fuse displayed readings

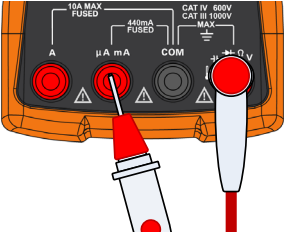
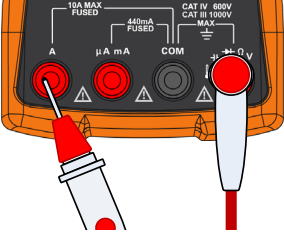
Current input terminal	Fuse	Part number	Fuse rating	Displayed readings	
				Fuse healthy	Replace fuse
	1	2110-1400	440 mA/1000 V	≈102 Ω	OL
	2	2110-1402	11 A/1000 V	≈0.05 Ω	OL

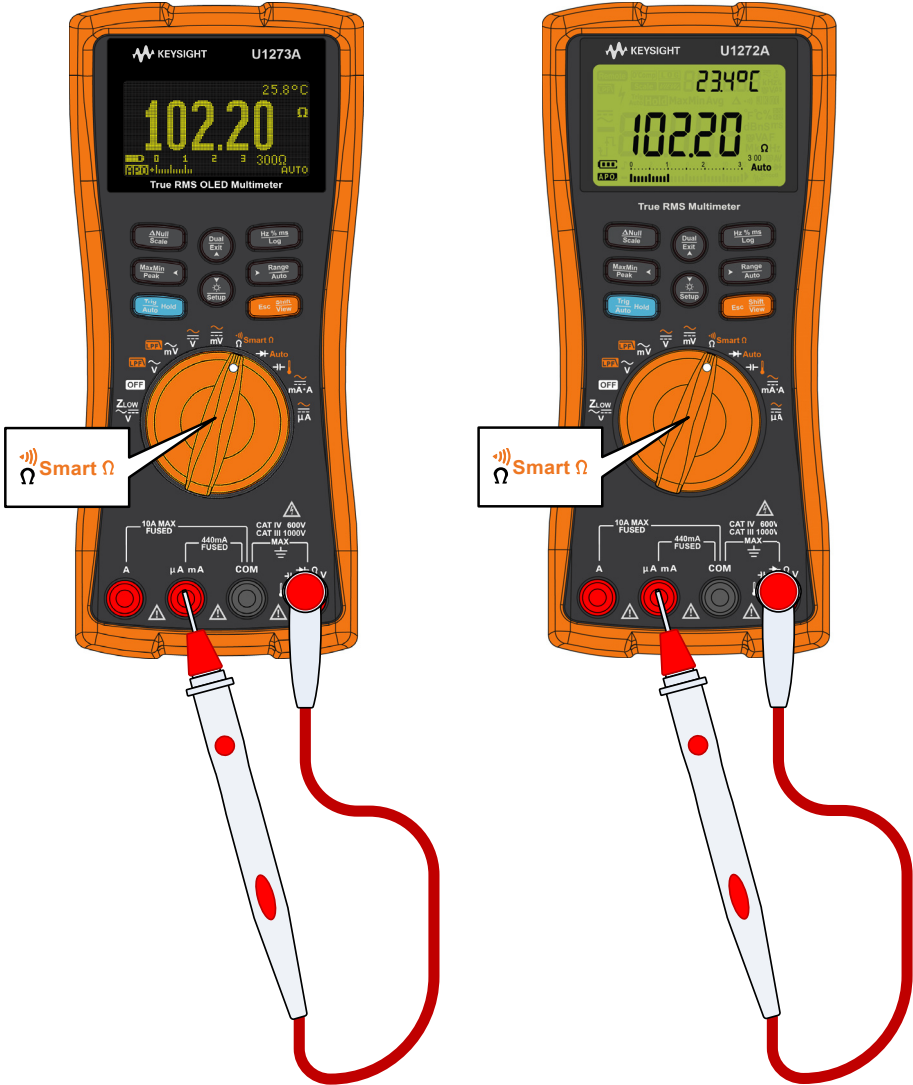

Figure 2-1 Testing Fuse 1

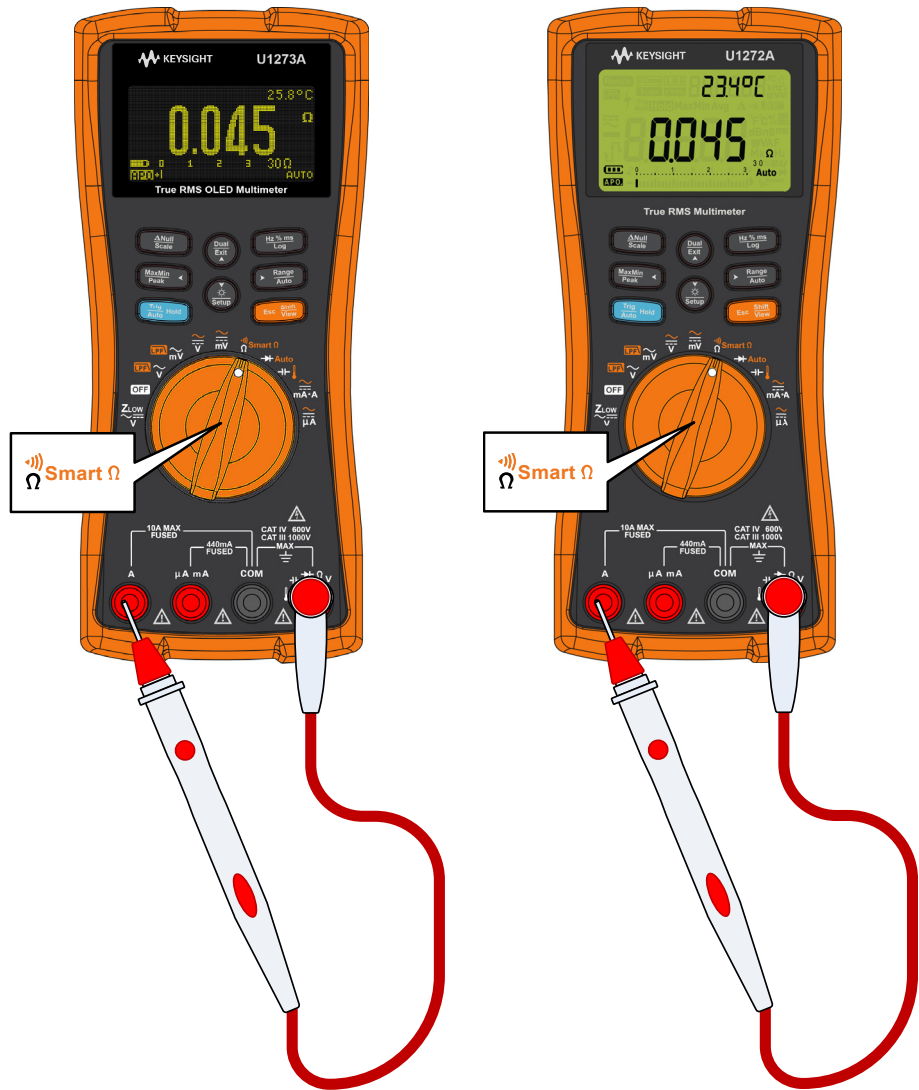

Figure 2-2 Testing Fuse 2

## Fuse Replacement

**NOTE**

No recalibration is required after replacing the fuse.

The current input terminals of your multimeter are fuse protected. The fuses are located next to the battery compartment.

- The **μA mA** terminal is protected by a 10 × 35 mm 440 mA/1000 V 30 kA fast-acting fuse (Fuse 1).
- The **A** terminal is protected by a 10 × 38 mm 11 A/1000 V 30 kA fast-acting fuse (Fuse 2).

If you are certain that the fuse is faulty, replace it with one of the same size and rating.

**CAUTION**

Before you proceed with the fuse replacement, remove all cable connections to the terminals and ensure that the rotary switch is at the OFF position.

- 1 Open the battery cover.** Lift the tilt stand and loosen screws with a suitable Phillips screwdriver and remove the battery cover.
- 2 Locate the faulty fuse.** Fuse 1 (see [Figure 2-3](#)) is located to the right of batteries, and Fuse 2 (see [Figure 2-4](#)) is located at the bottom of the batteries. See [Figure 2-5](#) for the specific location, size, and ratings of Fuse 1 and 2.  
Gently remove the defective fuse by prying one end of the fuse with a flathead screwdriver and removing it out of the fuse bracket. Replace a new fuse of the same size and rating into the center of the fuse holder.
- 3 Close the batter cover.** Place the battery cover back in its original position and tighten the screws.

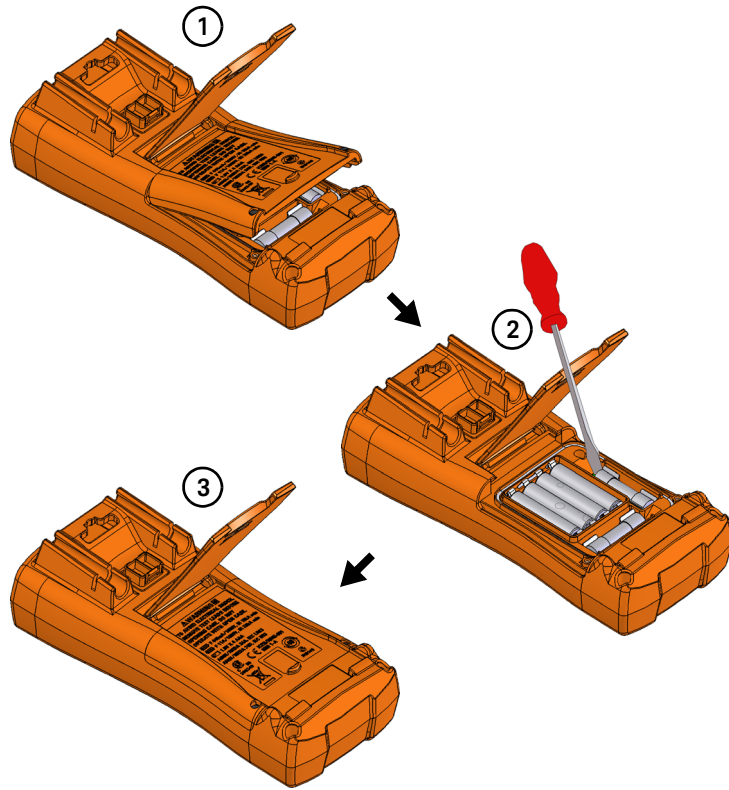

**Figure 2-3** Replacing Fuse 1



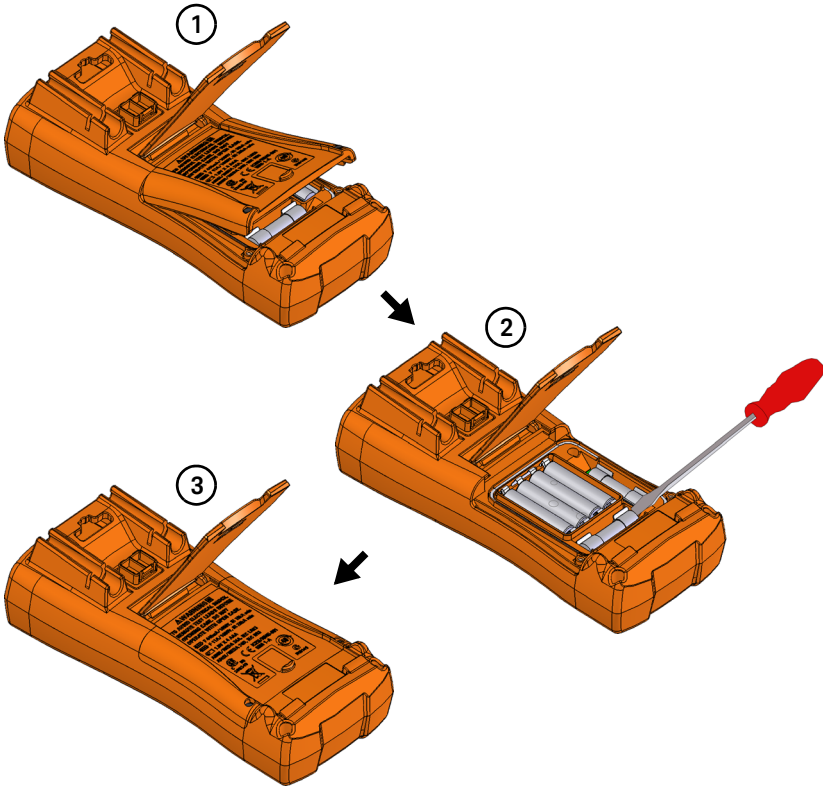
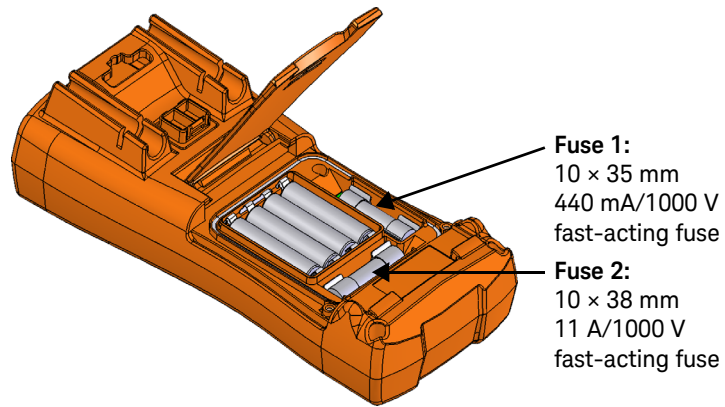

Figure 2-4 Replacing Fuse 2



**Figure 2-5** Positions of Fuse 1 and Fuse 2

## Returning the Instrument for Service

Before shipping your instrument for repair or replacement, Keysight recommends that you acquire the shipping instructions from the Keysight Service Center. A clear understanding of the shipping instructions is necessary to secure your product for shipment.

- 1** Attach a tag to the instrument with the following information:
  - Name and address of owner
  - Instrument model number
  - Instrument serial number
  - Description of the service required or failure indications
- 2** Remove all accessories from the instrument. Do not include accessories unless they are associated with the failure symptoms.
- 3** Place the instrument in its original container with appropriate packaging material for shipping.

If the original shipping container is not available, place your unit in a container which will ensure at least 4 inches of compressible packaging material around all sides for the instrument. Use static-free packaging materials to avoid additional damage to your unit.

**NOTE**

Keysight suggests that you always insure your shipments.

---

## Replaceable Parts

This section contains information for ordering replacement parts for your instrument. You can find the instrument support parts list at Keysight's Test & Measurement Parts Catalog: <http://www.keysight.com/find/parts>

The parts lists include a brief description of each part with its corresponding Keysight part number.

### To order replaceable parts

You can order replaceable parts from Keysight using the Keysight part number. Note that not all parts listed are available as field-replaceable parts.

To order replaceable parts from Keysight, do the following:

- 1** Contact your nearest Keysight Sales Office or Service Center.
- 2** Identify the parts by the Keysight part number shown in the support parts list.
- 3** Provide the instrument model number and serial number.

## Types of Service Available

If your instrument fails during the warranty period, Keysight will repair or replace it under the terms of your warranty. After your warranty expires, Keysight offers repair services at competitive prices.

### Extended service contracts

Many Keysight products are available with optional service contracts that extend the covered period after the standard warranty expires. If you have such a service contract and your instrument fails during the covered period, Keysight will repair or replace it in accordance with the contract.

## Obtaining Repair Service (Worldwide)

To obtain service for your instrument (in-warranty, under service contract, or post-warranty), contact your nearest Keysight Service Center. They will arrange to have your unit repaired or replaced, and can provide warranty or repair-cost information where applicable.

To obtain warranty, service, or technical support information you can contact Keysight at one of the following telephone numbers:

- In the United States: (800) 829-4444
- In Europe: 31 20 547 2111
- In Japan: 0120-421-345

Or use our Web link for information on contacting Keysight worldwide:

[www.keysight.com/find/assist](http://www.keysight.com/find/assist)

Or contact your Keysight representative.

Before shipping your instrument, request the Keysight Service Center to provide shipping instructions, including what components to ship. Keysight recommends that you retain the original shipping carton for use in such shipments.



This information is subject to change without notice. Always refer to the Keysight website for the latest revision.

© Keysight Technologies 2010–2020  
Edition 20, June 3, 2020

Printed in Malaysia



U1271-90020

[www.keysight.com](http://www.keysight.com)