

Up to 120 MHz (4-Terminal Pair): SMD *continued*

16034H Test fixture



Terminal connector: 4-Terminal Pair, BNC
DUT connection: 2-Terminal
Dimensions (approx.):
 120 (W) x 50 (H) x 70 (D) [mm]
Weight (approx.): 200 g
Additional error:

Type of error	Impedance
Proportional error	$0.5 \times (f/10)^2$ [%]
Open repeatability	$5 + 500 \times (f/10)$ [nS]
Short repeatability	$10 + 13 \times (f/10)$ [mΩ]

f: [MHz]

Description: This test fixture is designed for impedance evaluations of array-type SMD. The minimum SMD size that this fixture is adapted to evaluate is 1.6(L) x 0.8(W) [mm]. Since the tip of the measurement electrodes are very thin and the device holder is extremely flat, the device can be shifted and the measurement electrodes can contact the each element of the array-type component.

Applicable instruments: E4980A/AL, E4981A, E4990A, E5061B-3L3/3L4/3L5 with Opt. 005

Frequency: DC to 120 MHz

Maximum voltage: ±42 V peak max. (AC+DC)

Operating temperature: 0 to 55°C

DUT size: See figure below

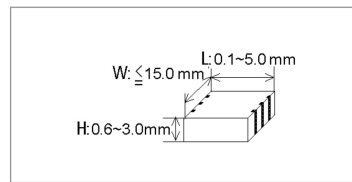

Furnished accessories:

Description	P/N	Qty.
Case for 100 Ω SMD resistance	1540-0692	1
100 Ω chip resistor	0699-2488	10
Operating manual	16034-90012	1

Compensation and measurement: Open and short compensations are recommended before measurement. When measuring above 3 MHz, load compensation is also recommended. Open compensation is performed by separating the high and the low electrodes from each other. The separation should be equivalent in size to the DUT's width. Short compensation is performed by placing the high and low electrodes in contact together. Load compensation is performed by using the furnished 100 Ω SMD chip resistor. After performing open, short and load compensations, the DUT is inserted into the test fixture. Refer to the 16034G figures to see how compensation and measurement are performed.

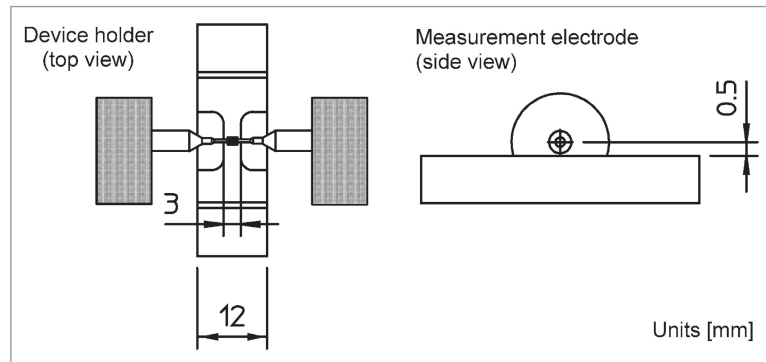

Electrode dimensions

