

Keysight 16192A Parallel Electrode SMD Test Fixture

Operation and
Service Manual

Notices

© Keysight Technologies
1993 - 2019

No part of this manual may be reproduced in any form or by any means (including electronic storage and retrieval or translation into a foreign language) without prior agreement and written consent from Keysight Technologies, Inc. as governed by United States and international copyright laws.

Manual Part Number

16192-90040

Edition

Edition 8, August 26, 2019

Printed in Malaysia

Published by:

Keysight Technologies International
Japan G.K.,
1-3-3 Higashikawasaki-cho
Chuo-ku
Kobe-shi, Hyogo, Japan

Warranty

THE MATERIAL CONTAINED IN THIS DOCUMENT IS PROVIDED "AS IS," AND IS SUBJECT TO BEING CHANGED, WITHOUT NOTICE, IN FUTURE EDITIONS. FURTHER, TO THE MAXIMUM EXTENT PERMITTED BY APPLICABLE LAW, KEYSIGHT DISCLAIMS ALL WARRANTIES, EITHER EXPRESS OR IMPLIED WITH REGARD TO THIS MANUAL AND ANY INFORMATION CONTAINED HEREIN, INCLUDING BUT NOT LIMITED TO THE IMPLIED WARRANTIES OF MERCHANTABILITY AND FITNESS FOR A PARTICULAR PURPOSE. KEYSIGHT SHALL NOT BE LIABLE FOR ERRORS OR FOR INCIDENTAL OR CONSEQUENTIAL DAMAGES IN CONNECTION WITH THE FURNISHING, USE, OR PERFORMANCE OF THIS DOCUMENT OR ANY INFORMATION CONTAINED HEREIN. SHOULD KEYSIGHT AND THE USER HAVE A SEPARATE WRITTEN AGREEMENT WITH WARRANTY TERMS COVERING THE MATERIAL IN THIS DOCUMENT THAT CONFLICT WITH THESE TERMS, THE WARRANTY TERMS IN THE SEPA-

RATE AGREEMENT WILL CONTROL.

Technology Licenses

The hardware and/or software described in this document are furnished under a license and may be used or copied only in accordance with the terms of such license.

Declaration of Conformity

Declarations of Conformity for this product and for other Keysight products may be downloaded from the Web. Go to <http://www.keysight.com/go/conformity>. You can then search by product number to find the latest Declaration of Conformity.

U.S. Government Rights

The Software is "commercial computer software," as defined by Federal Acquisition Regulation ("FAR") 2.101. Pursuant to FAR 12.212 and 27.405-3 and Department of Defense FAR Supplement ("DFARS") 227.7202, the U.S. government acquires commercial computer software under the same terms by which the software is customarily provided to the public. Accordingly, Keysight provides the Software to U.S. government customers under its standard commercial license, which is embodied in its End User License Agreement (EULA), a copy of which can be found at <http://www.keysight.com/find/sweula>. The license set forth in the EULA represents the exclusive authority by which the U.S. government may use, modify, distribute, or disclose the Software. The EULA and the license set forth therein, does not require or permit, among other things, that Keysight: (1) Furnish technical information related to commercial computer software or commercial computer software documentation that is not customarily provided to the public; or (2) Relinquish to, or otherwise provide, the government rights in excess of these rights customarily provided to the public to use, modify, reproduce, release, perform, display, or disclose commercial computer software or commercial computer software documentation. No additional government requirements beyond those set forth in the EULA shall

apply, except to the extent that those terms, rights, or licenses are explicitly required from all providers of commercial computer software pursuant to the FAR and the DFARS and are set forth specifically in writing elsewhere in the EULA. Keysight shall be under no obligation to update, revise or otherwise modify the Software. With respect to any technical data as defined by FAR 2.101, pursuant to FAR 12.211 and 27.404.2 and DFARS 227.7102, the U.S. government acquires no greater than Limited Rights as defined in FAR 27.401 or DFARS 227.7103-5 (c), as applicable in any technical data.

Safety Notices

CAUTION

A **CAUTION** notice denotes a hazard. It calls attention to an operating procedure, practice, or the like that, if not correctly performed or adhered to, could result in damage to the product or loss of important data. Do not proceed beyond a **CAUTION** notice until the indicated conditions are fully understood and met.

WARNING

A **WARNING** notice denotes a hazard. It calls attention to an operating procedure, practice, or the like that, if not correctly performed or adhered to, could result in personal injury or death. Do not proceed beyond a **WARNING** notice until the indicated conditions are fully understood and met.

1. General Information	
Introduction	5
Manual Summary	5
Product Description	5
Applicable Instruments	6
Options Available	6
Accessories Supplied	7
Specifications	8
Supplemental Performance Characteristics	9
Residual Inductance of the Shorting Bar	10
2. Preparation for Use	
Introduction	13
Initial Inspection	13
Adjusting the Configuration to SMD Size	15
Connecting the Test Fixture for Use	16
Repackaging the Test Fixture For Shipment	17
Measurement Error Correcting Function for Each Instrument	18
3. Operation	
Introduction	19
Operating Flow	19
Overview	21
How to Set the SHORT Condition, and the OPEN Condition	23
Setting the SHORT Condition	23
Setting the OPEN Condition	25
How to Connect the DUT	26
4. Service	
Introduction	27
General Information	27
Assembly Replacement	29
Disassembly and Assembly Procedure	29
Length Positioning Stage Assembly Removal:	29
Width Positioning Stage Assembly Removal:	29
Replaceable Parts	30
Troubleshooting	38
Open Impedance Check	38
Short Impedance Check	39

Contents

Short Impedance Repeatability Check 40

1 General Information

Introduction

The purpose of this manual is to enable you to use your 16192A Parallel Electrode SMD Test Fixture efficiently and confidently.

Manual Summary

This manual contains the following:

- The specifications of the 16192A (see this chapter).
- Installing the 16192A (see [Chapter 2](#)).
- Operating the 16192A (see [Chapter 3](#)).
- Ordering replaceable parts for the 16192A (see [Chapter 4](#)).

Product Description

The 16192A is used to measure a parallel electrodes surface mount device (SMD) with high repeatability.

Applicable Instruments

The 16192A has been designed to operate specifically with the following LCR meters and impedance analyzers:

E4982A

E4990A¹ + 42942A

E4991B

E5061B- 3L3/3L4/3L5² + 16201A

1. Option E4990A-120 is required.
2. Option 005 is required.

Options Available

The following option is supplied for the 16192A:

- | | |
|------------|--|
| Option 010 | Add industry standard size short bar set |
| Option 701 | Short bars set (1x1x2.4, 1.6x2.4x2, 3.2x2.4x2.4, 4.5x2.4x2.4) mm |
| Option 710 | Add the magnifying lens and tweezers |
| Option ABA | Operation and Service Manual |

Accessories Supplied

The following accessories are supplied with the 16192A:

Table 1-1

Furnished Accessories

Description	Part Number	Quantity
Operation and Service Manual	Option ABA	1
Option 701	P/N 16191-29001	1
	P/N 16191-29002	1
	P/N 16191-29003	1
	P/N 16191-29004	1
Case for shorting devices	P/N 1540-0692	1
Option 010 ¹	P/N 16191-29005	1
	P/N 16191-29006	1
	P/N 16191-29007	1
	P/N 16191-29008	1
Magnifying lens ²	P/N 16193-60002	1
Tweezers ²	P/N 8710-2081	1
Insulator	P/N 16192-09002	1

- Option 010 sizes are the same as industry standard (EIA/EIAJ) SMD sizes. This short bar set has the following SMD sizes included: 1005(mm)/0402(inch), 1608(mm)/0603(inch), 2012(mm)/0805(inch), 3216(mm)/1206(inch). Order Option 010 if the SMD that is to be measured has the same size as the EIA/EIAJ sizes.
- Furnished with the Option 710.

Specifications

This section lists the complete 16192A specifications. These specifications are the performance standards and limits against which the 16192A is tested. When shipped from the factory, the 16192A meets the following specifications:

Maximum DC Bias Voltage	±42 V peak max (AC+DC)
Operating Temperature	-55 to +85 °C
Operating Humidity (@wet bulb temperature <40 °C)	15% to 95% RH
Non-operating Temperature	-55 to +85 °C
Non-operating Humidity (@wet bulb temperature <65 °C)	Up to 90% RH
Weight	400 g
Dimension	150(W) × 70(H) × 90(D) [mm]

Supplemental Performance Characteristics

This section lists supplemental performance characteristics. Supplemental performance characteristics are not specifications, but are typical characteristics included as additional information for the operator. Supplemental performance characteristics are not guaranteed.

Frequency Range	DC to 2 GHz
Applicable DUT Size (see Figure 1-1)	1 mm to 20 mm
Option 701 Shorting Device Size	
P/N 16191-29001	1 × 1 × 2.4 [mm]
P/N 16191-29002	1.6 × 2.4 × 2 [mm]
P/N 16191-29003	2.4 × 2.4 × 3.2 [mm]
P/N 16191-29004	2.4 × 2.4 × 4.5 [mm]
Option 701 Shorting Device Size	
P/N 16191-29005	1.0(L) × 0.5(W) × 0.5(H) [mm]
P/N 16191-29006	1.6(L) × 0.8(W) × 0.8(H) [mm]
P/N 16191-29007	2.0(L) × 1.2(W) × 0.8(H) [mm]
P/N 16191-29008	3.2(L) × 1.6(W) × 0.8(H) [mm]
Electrical Length (when the length between electrodes is 2 mm)	11 mm
Additional Error ¹	1.5 × f ² [%]
Repeatability ¹	
(for inductive component)	30 + 250 × f [mΩ] (impedance of 30 mΩ, 40 pF)
	2 + 30 × f [μS] (admittance of 2 μS, 5 fF)

1. f: frequency (GHz)

Figure 1-1 Applicable DUT Size

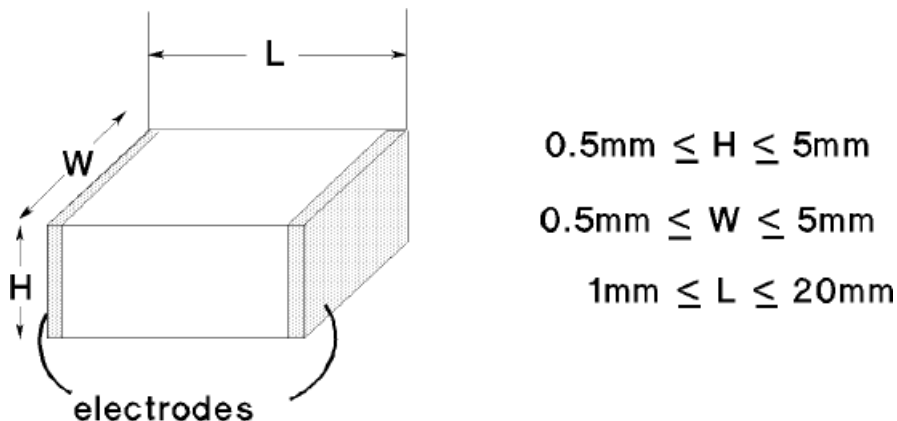

Residual Inductance of the Shorting Bar

The usual method to compensate the test fixture's residual inductance is to let SHORT = 0H. In this method, the measurement result is the relative value of the measured impedance to the shorting bar's impedance. The short bar's residual inductance as a result of its size and shape is not estimated.

On the other hand, there is a definition method to let SHORT = x H. In this method, the measurement result is the absolute value of the device's impedance. The short bar's residual inductance as a result of its size and shape is estimated under specific conditions and is used as a reference value. This method, is useful for devices with values which are close to the short conditions of the measurement system.

The reference inductance values presented [Table 1-2](#) and [Table 1-3](#) were simulated as the relative difference to a disk-type 0 Ω termination on either the 7 mm or the 3.5 mm connector. The measurement of these short bars under other conditions than shown below cannot reproduce the reference inductance values.

Table 1-2 Option 701 Shorting Device Residual Inductance (Typical)

Shorting Bar	l [mm]	d [mm]	h [mm]	Offset [mm]	Connector	Inductance (Typical)
P/N 16191-29001	1	2.4	1	0.75	3.5 mm	0.2 nH
P/N 16191-29002	1.6	2.4	2	0.45	3.5 mm	0.2 nH
P/N 16191-29002	2	2.4	1.6	0.25	3.5 mm	0.2 nH
P/N 16191-29002	2.4	2	1.6	1.3	7 mm	0.7 nH
P/N 16191-29003	3.2	2.4	2.4	0.9	7 mm	0.6 nH
P/N 16191-29004	4.5	2.4	2.4	0	7 mm	0.6 nH

Table 1-3 Option 010 Shorting Device Residual Inductance (Typical)

Shorting Bar	l [mm]	d [mm]	h [mm]	Offset [mm]	Connector	Inductance (Typical)
P/N 16191-29005	1.0	0.5	0.5	0.75	3.5 mm	0.5 nH
P/N 16191-29006	1.6	0.8	0.8	0.45	3.5 mm	0.4 nH
P/N 16191-29007	2.0	1.2	0.8	1.5	7 mm	0.9 nH
P/N 16191-29008	3.2	1.6	0.8	0.9	7 mm	0.8 nH

Figure 1-2 Simulation Setup

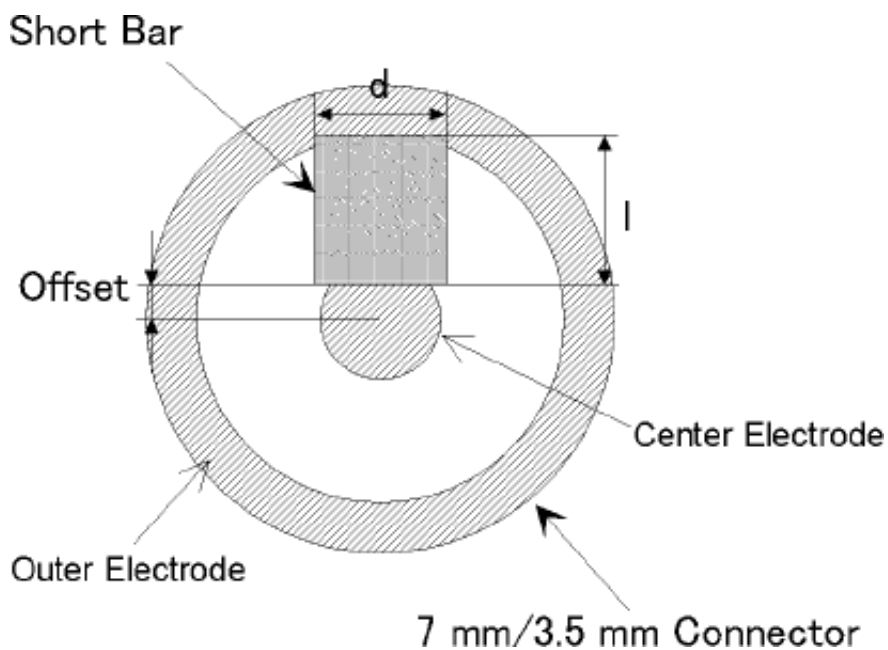

General Information
Residual Inductance of the Shorting Bar

2 Preparation for Use

Introduction

This chapter explains how to install the 16192A. The topics include the following:

- Initial inspection.
- Connecting the test fixture for use.
- Repackaging the test fixture for shipment.
- Measurement error correcting function for each instrument.

Initial Inspection

The parallel electrode SMD test fixture has been carefully inspected before being shipped from the factory. It should be in perfect physical condition, no scratches, dents or the like. It should also be in perfect electrical condition. Verify this by carefully performing an incoming inspection to check the parallel electrode SMD test fixture set for signs of physical damage and missing contents. If any discrepancy is found, notify the carrier and Keysight Technologies. Your Keysight Technologies sales office will arrange for repair and replacement without waiting for the claim to be settled.

- Inspect the shipping container for damage. Keep the shipping materials until the inspection is completed.
- Verify that the shipping container contains everything shown in **Figure 2-1** and listed in **Table 2-1**.
- Inspect the exterior of the 16192A for any signs of damage.

Figure 2-1 16192A Product Overview

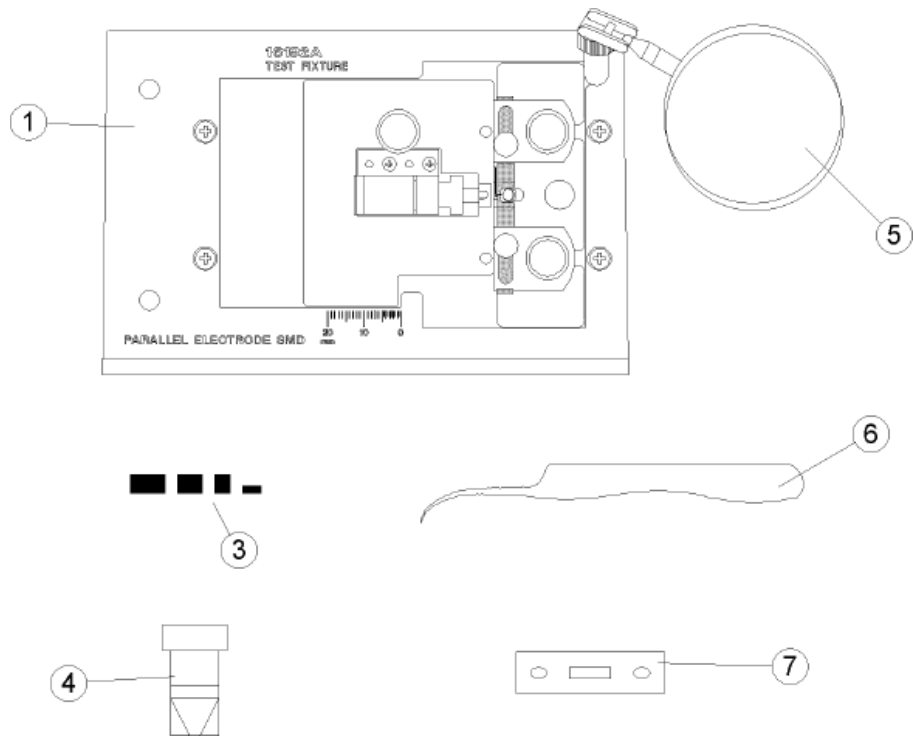

Table 2-1 16192A Contents

Description	Keysight Part Number	Quantity
1 Test fixture	16192A	1
2 Operation and Service Manual ¹	Option ABA	1
3 Shorting device ² (1×1×2.4[mm]) (1.6×2.4×2[mm]) (2.4×2.4×3.2[mm]) (2.4×2.4×4.5[mm])	P/N 16191-29001	1
	P/N 16191-29002	1
	P/N 16191-29003	1
	P/N 16191-29004	1
4 Case for shorting device	P/N 1540-0692	1
5 Magnifying lens ^{3,4}	P/N 16193-60002	1
6 Tweezers ⁴	P/N 8710-2081	1
7 Insulator	P/N 16192-09002	1

1. Operation and Service Manual is not shown in [Figure 2-1](#).
2. Contained if you ordered the 16192A Option 701.
3. The magnifying lens is packed separately from the 16192A body. Connect it as shown in [Figure 2-1](#).
4. Contained if you ordered the 16192A Option 710.

Adjusting the Configuration to SMD Size

The 16192A's applicable SMD size is 1 mm to 20 mm, changing the electrodes configuration as follows.

Figure 2-2 Electrodes Configuration and SMD Size

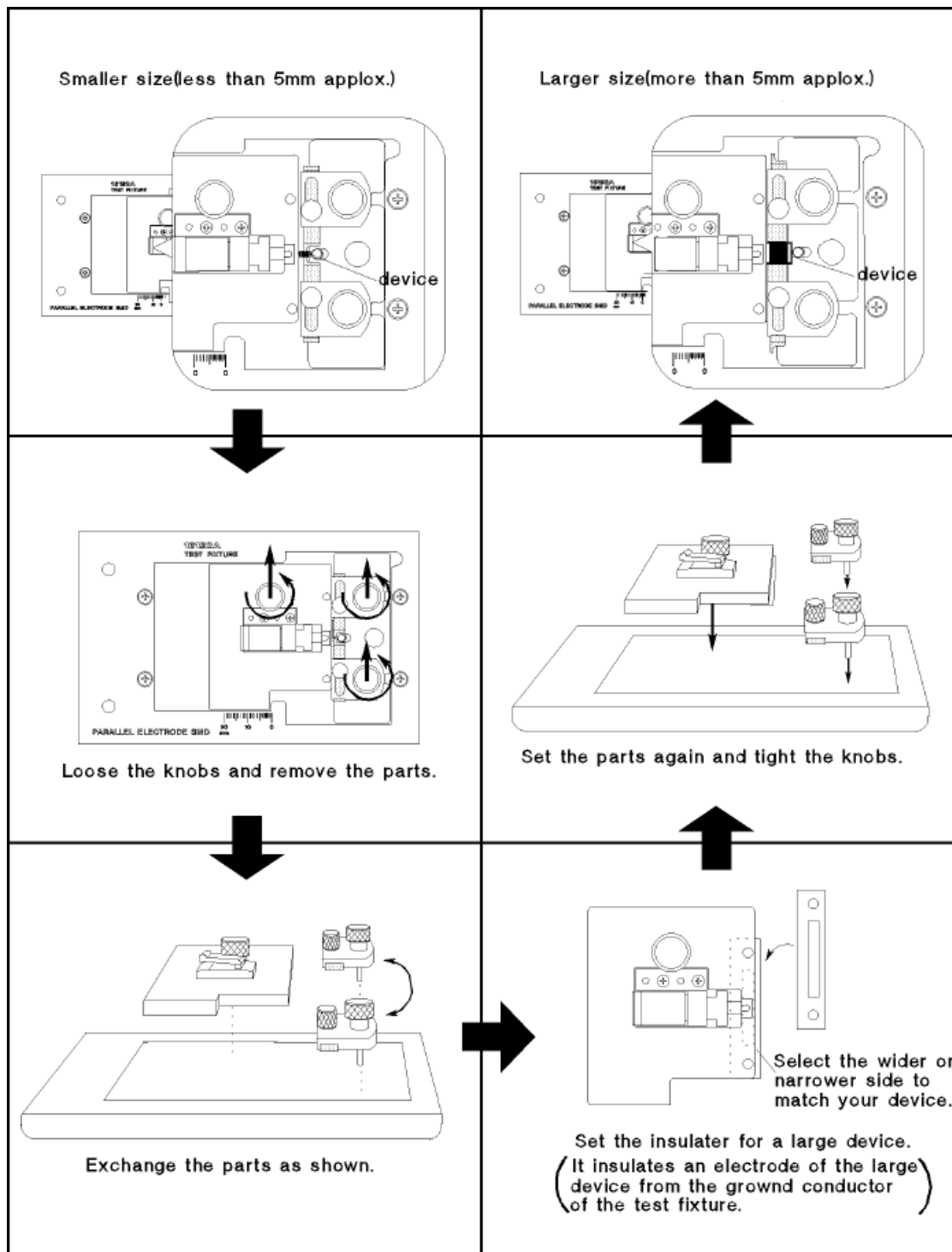

AC102002

Connecting the Test Fixture for Use

NOTE

When measuring high value capacitors, allow sufficient time for the capacitor to charge to the applied voltage.

1. Calibrate your analyzer at the APC-7[®] connector plane before connecting the test fixture. See Table 2-2 for the applicable error correcting function. After calibration, disconnect any standards from the APC-7[®] connector.
2. Place the fixture on the APC-7[®] connector.
3. Tighten (turn counterclockwise) the coupling nut of the APC-7[®] connector.

Figure 2-3 Connecting the Test Fixture with APC-7[®] Connector

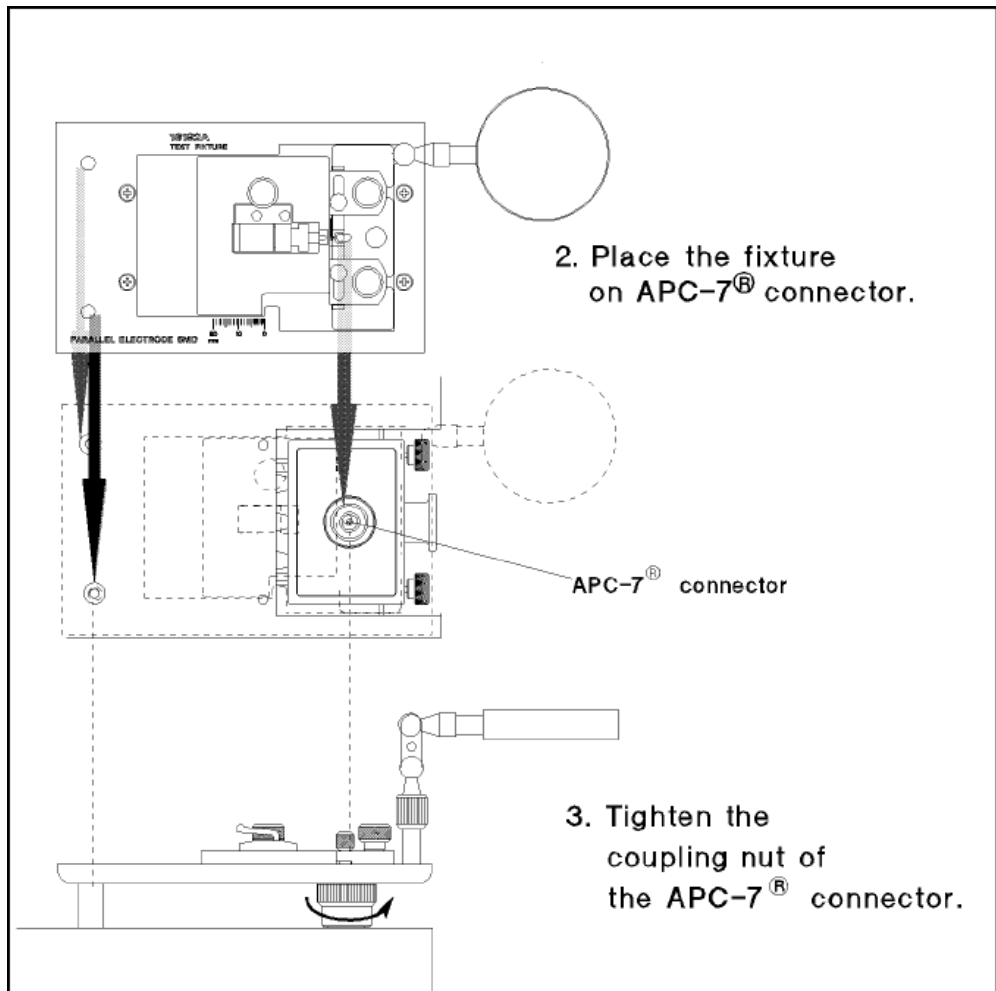

Repackaging the Test Fixture For Shipment

If shipment to a Keysight Technologies service center is required, each test fixture should be repackaged using the original factory packaging materials.

If this material is not available, comparable packaging materials may be used. Wrap the parallel electrode SMD test fixture in heavy paper and pack in anti-static plastic packing material. Use sufficient shock absorbing material on all sides of the 16192A to provide a thick, firm cushion and to prevent movement. Seal the shipping container securely and mark it *FRAGILE*.

Measurement Error Correcting Function for Each Instrument

Each LCR meter or analyzer has measurement error correcting functions. **Table 2-2** shows the functions of the instrument that can be used for calibration, setting the electrical length, and Open/Short/Load compensation.

Table 2-2 Measurement Error Correcting Functions for Each Instrument

Instrument	Calibration	Electrical Length	OPEN Compensation	SHORT Compensation	LOAD Compensation
E4991B	Calibration OPEN SHORT LOAD LOW-LOSS Capacitor ¹	Electrical Length	OPEN Correction	SHORT Correction	No capability
E4990A ² with 42942A	Adapter Setup OPEN SHORT LOAD	No capability	OPEN Correction	SHORT Correction	LOAD Correction ¹
E4982A	Calibration OPEN SHORT LOAD LOW-LOSS Capacitor ¹	Electrical Length	OPEN Correction	SHORT Correction	No capability
E5061B-3L3/3L4/3L5 ³ with 16201A	Calibration OPEN SHORT LOAD LOW-LOSS Capacitor ¹	Electrical Length	OPEN Correction	SHORT Correction	No capability

1. According to demand for precise measurement.
2. Option E4990A-120 is required.
3. Option 005 is required.

3 Operation

Introduction

This chapter describes how to use the test fixture and the measurement error correcting techniques for the test fixture.

Operating Flow

Before performing a measurement, you have to compensate for the residual error of the test fixture by using the measurement error correcting functions. Perform the following steps when measuring the DUT:

The 16192A has inherent stray capacitance, residual inductance, and residual resistance that affect the measurement. To compensate for these residuals and thus minimize their effect on measurement accuracy, the measurement instrument's OPEN and SHORT compensation capabilities must be used.

(▶ indicates procedures in the following pages.)

- Select the DUT size
- Calibrate your analyzer
- Connect the Test Fixture

Described in [Chapter 2](#), "Preparation for Use."



Set the electrical length¹

The 16192A's electrical length is 11 mm (typical value). To set the electrical length, see your analyzer's Operation Manual.



Operation
Operating Flow

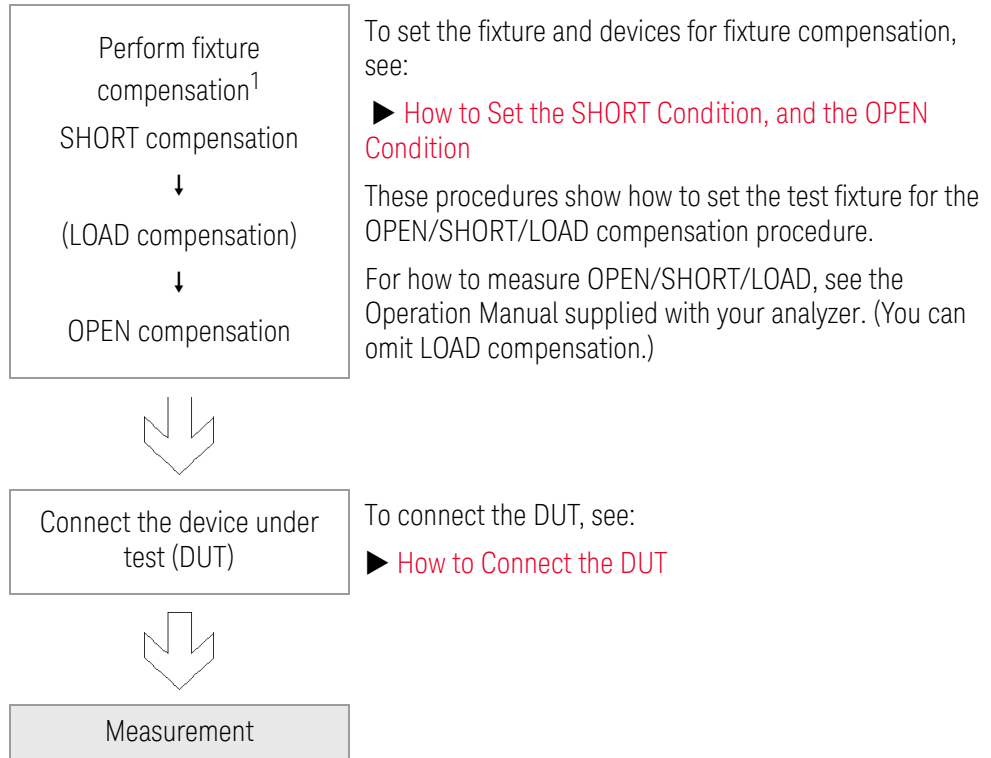

1. The compensating functions are different for each instrument. See [Table 2-2](#) and perform the listed functions.

Overview

Figure 3-1 16192A Test Fixture Overview

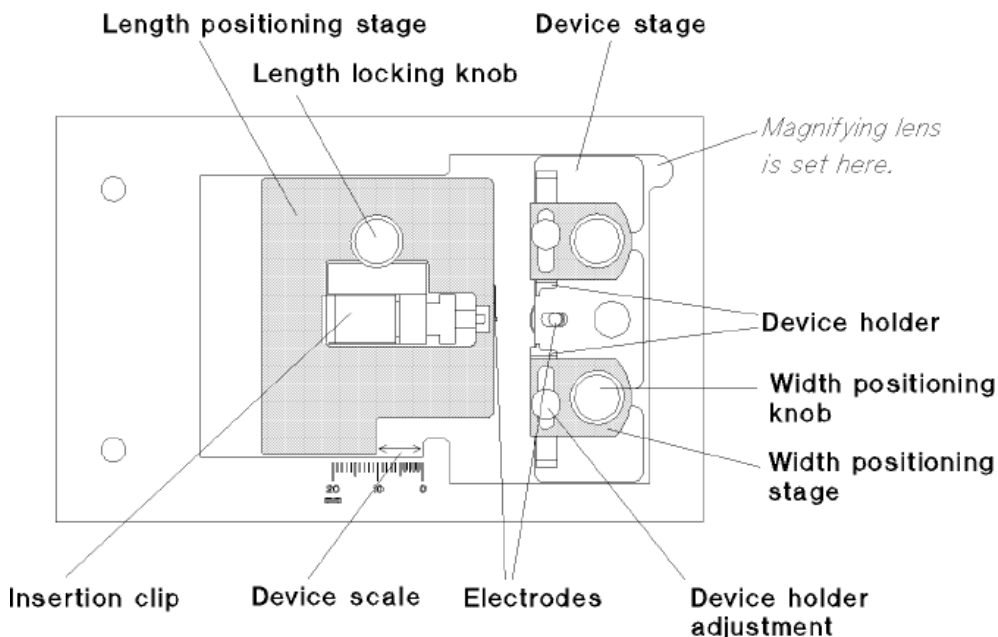

Length positioning stage	Slides to fix an electrode.
Length locking knob	Fixes the length positioning stage.
Device stage	PTFE sheet to place the device.
Device holder	Fixes a device.
Width locking knob	Fixes the width positioning stage.
Width positioning stage	Fixes the device holder and the device stage.
Device holder adjustment	Moves the device holder.
Electrodes	These are connected to the device.
Device scale	Used for rough adjustment of the length positioning stage.
Insertion clip	Tightens or loosens an electrode.
Shorting device	(<i>Not shown in Figure 3-1</i>) Used for short compensation.
Magnifying lens	(<i>Not shown in Figure 3-1</i>) Used when placing a small device within the electrodes.

If you ordered the Option 010 or 701, four types of shorting devices are supplied with the 16192A. Use one that has dimensions similar to the DUT. When making a shorting device of same dimensions as your DUT, very low residual impedance and a high conductivity metal (that is not easily corroded) must be used to construct the shorting device. (It must also be clean.)

WARNING

DO NOT look at the sun through the magnifying glass.

DO NOT operate or leave the magnifying glass under direct sunlight.

How to Set the SHORT Condition, and the OPEN Condition

Setting the SHORT Condition

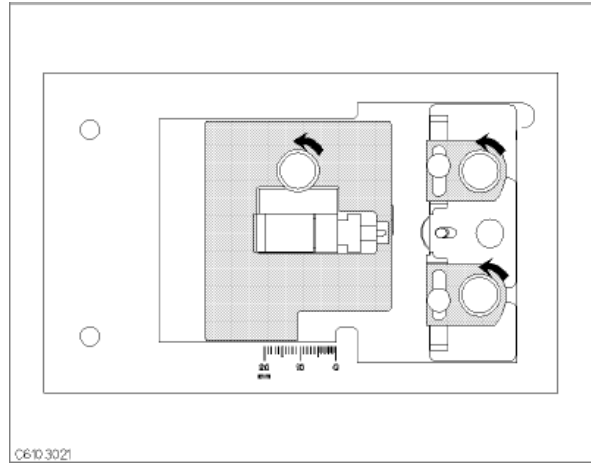
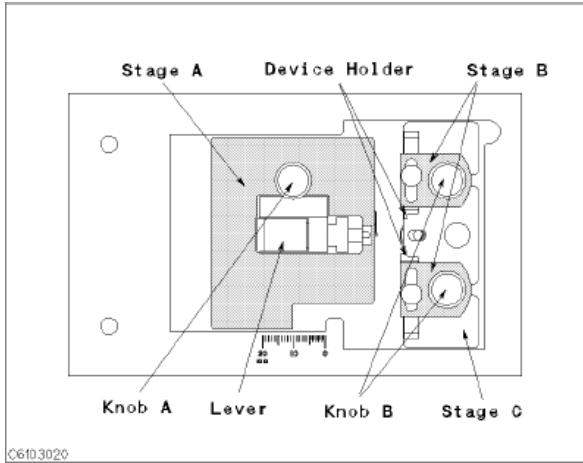

The names of each part are listed above.

1. Loosen the three knobs.

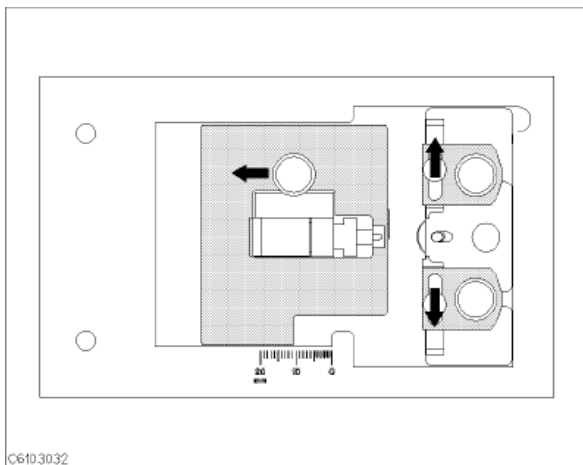

2. Move stage A and the two device holders to the outside.

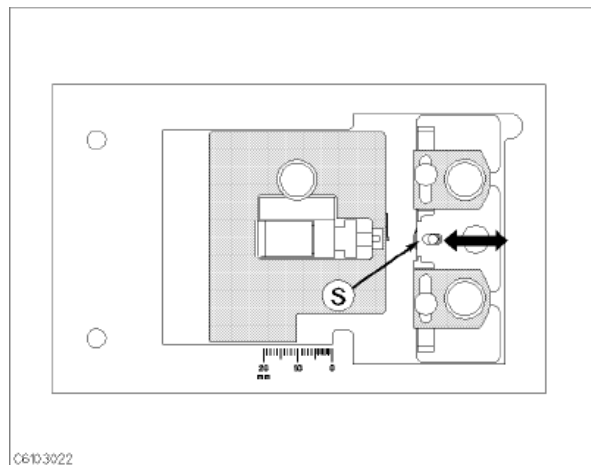

3. Adjust stage C so that the shorting device is placed on position \textcircled{S} .

Operation
How to Set the SHORT Condition, and the OPEN Condition

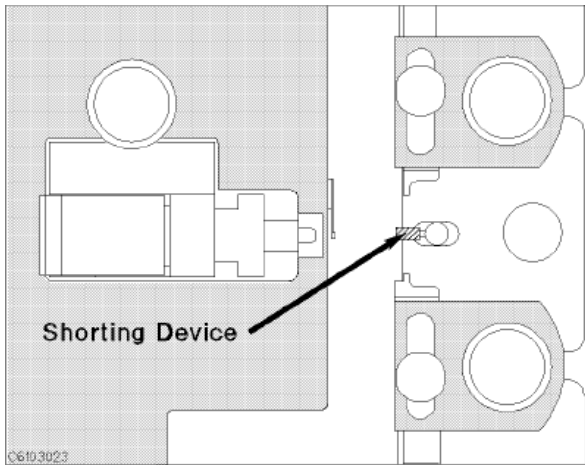

4. Place the shorting device so that it contacts the electrode.

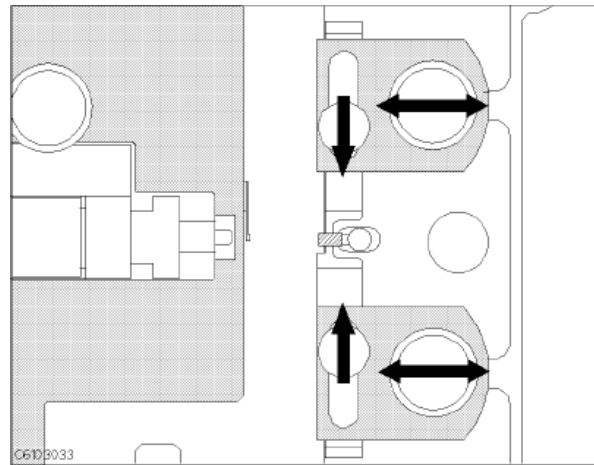

5. Adjust the two B stages and the two device holders to hold the shorting device.

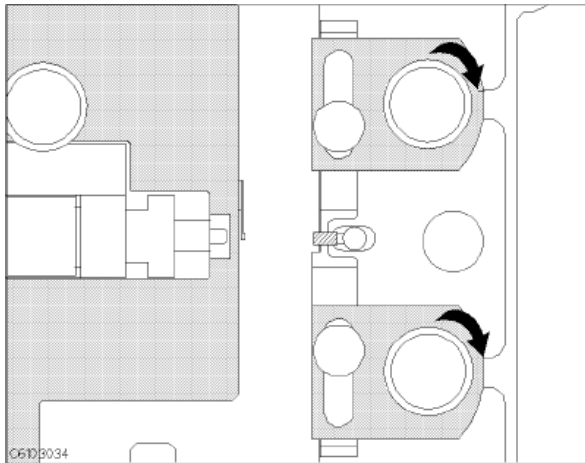

6. Tighten the two B knobs to fix the B stages and the device holders.

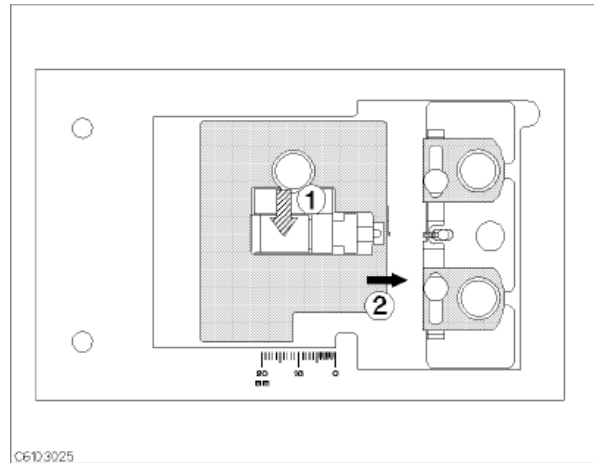

7. ① Push the lever. ② Slide stage A while pushing the lever until the electrode on the stage A slightly contacts the shorting device.

Operation
How to Set the SHORT Condition, and the OPEN Condition

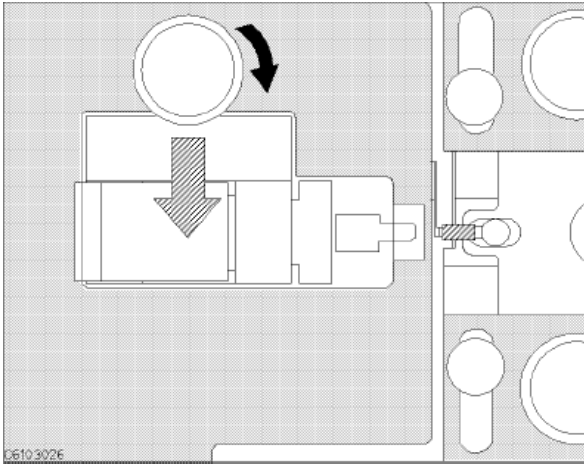

8. Tighten knob A while pushing the lever.

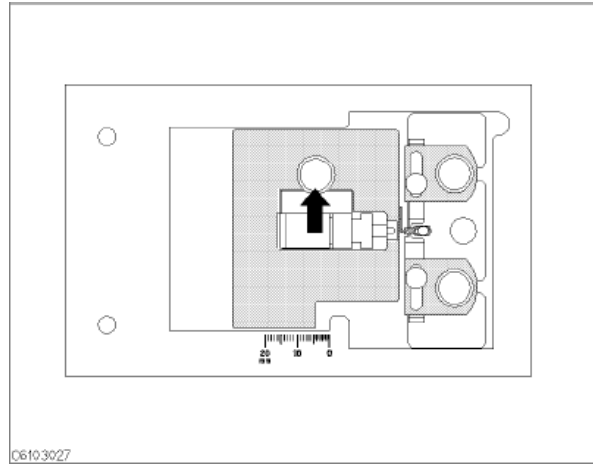

9. Release the lever to hold the shorting device.

Setting the OPEN Condition

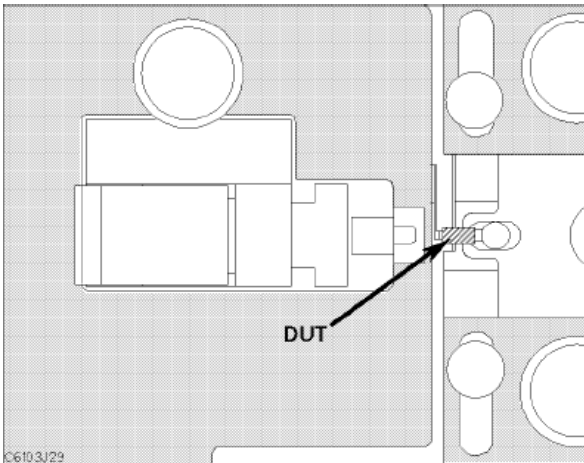

1. Set the DUT on the test fixture just as you set the shorting device in the SHORT compensation.

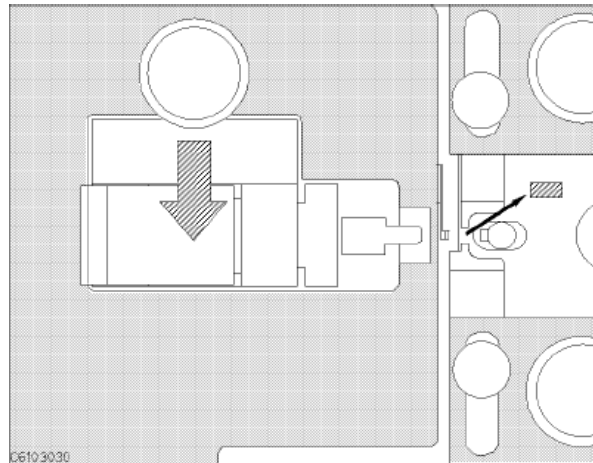

2. Push the black lever and remove the DUT.

Operation
How to Connect the DUT

How to Connect the DUT

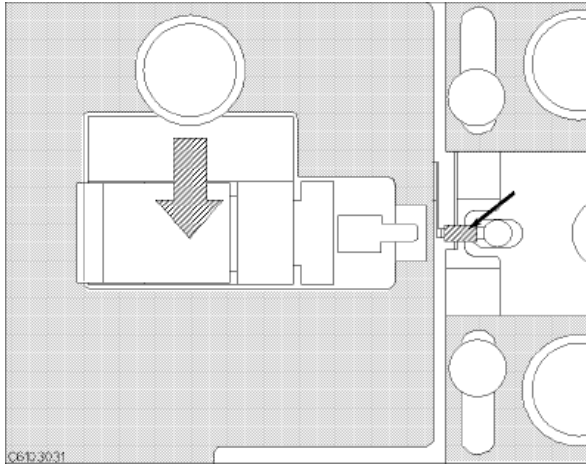

1. Push the lever and place the DUT on the electrode.

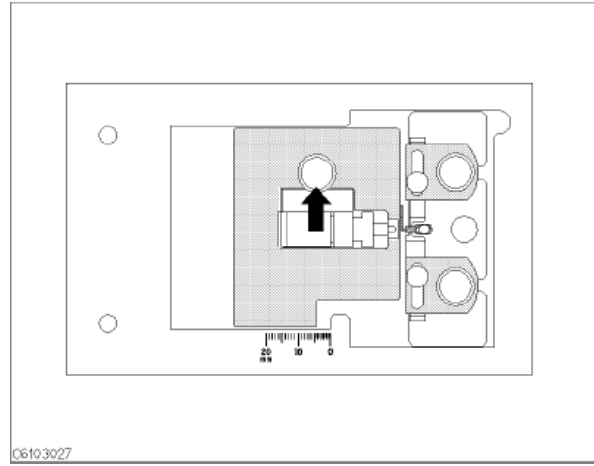

2. Release the lever to hold the DUT.

4 Service

Introduction

This chapter explains how to install the 16192A. The topics include the following:

- General Information
- Assembly Replacement
 - Disassembly Procedure for main assembly
 - Replaceable Parts
- Troubleshooting

WARNING

These servicing instructions are for use by qualified personnel only. Do NOT perform any servicing (other than that contained in the operating section) unless you are qualified to do so.

CAUTION

When you repair the 16192A, put on lint-free gloves to avoid contaminating inner parts of the 16192A.

General Information

Table 4-1 shows all items included with the 16192A Parallel Electrode SMD Test Fixture.

Serial numbers for Non-RoHS 16192A: “MY431xxxxx and below” / “SG431xxxxx and below”

Serial numbers for RoHS 16192A: “MY432xxxxx and above” / “SG432xxxxx and above”

Figure 4-1 16192A Product Overview

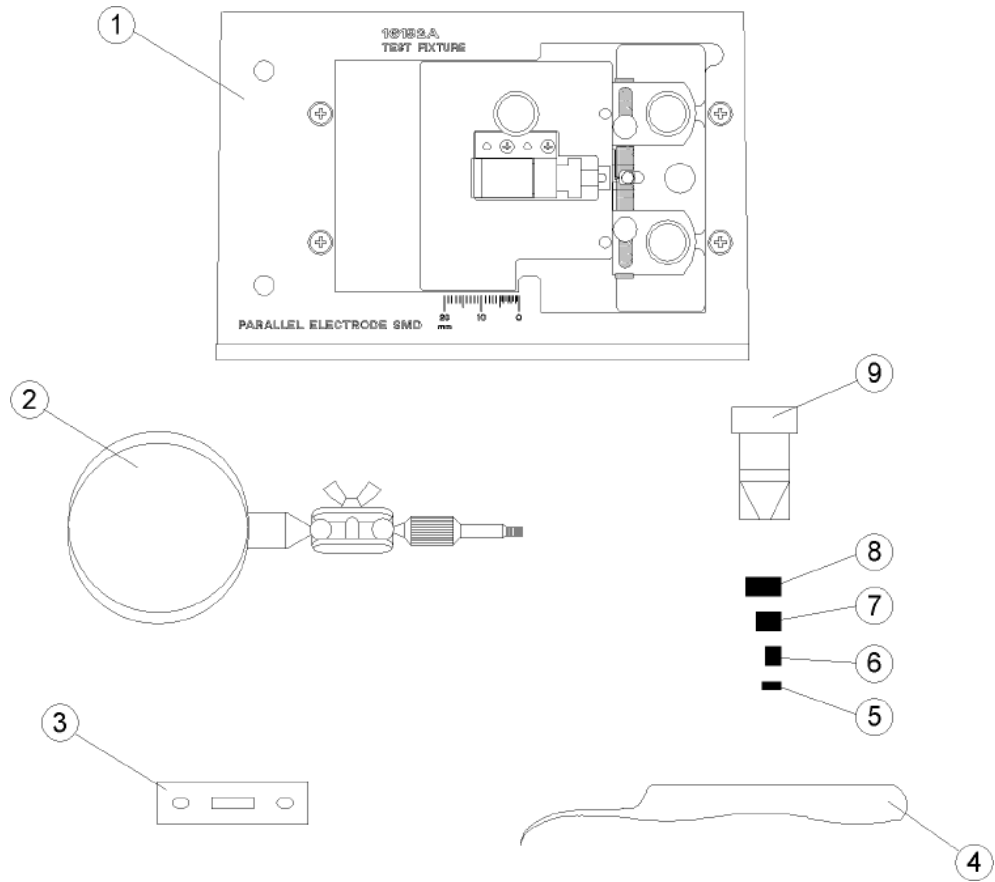

Table 4-1 16192A Product Overview

Reference Designator	Keysight Part Number	RoHS Compliant Replacement Part Number	Qty	Description
1	(not assigned)	(not assigned)	1	Main Assembly
2	16193-60002	16193-60002	1	Magnifying Glass ¹
3	16192-09002	16192-09002	1	Insulator
4	8710-2081	8710-2081	1	Tweezers ¹
5	16191-29001	16191-29001	1	Shorting Device (1×1×2.4 mm) ²
6	16191-29002	16191-29002	1	Shorting Device (1.6×2.4×2 mm) ²
7	16191-29003	16191-29003	1	Shorting Device (2.4×2.4×3.2 mm) ²

Table 4-1 16192A Product Overview (Continued)

Reference Designator	Keysight Part Number	RoHS Compliant Replacement Part Number	Qty	Description
8	16191-29004	16191-29004	1	Shorting Device (2.4×2.4×4.5 mm) ²
9	1540-0692	1540-0692	1	Case for Shorting Devices
-	16191-29021	16191-29021	1	Styrofoam Holder ³
-	Option ABA	Option ABA	1	Operation and Service Manual ³

1. Contained if you ordered the 16191A Option 710.
2. Contained if you ordered the 16191A Option 701.
3. Not shown in the figure.

Assembly Replacement

This section includes Disassembly and Assembly Procedures and Replacement Parts for the Main Assembly.

Disassembly and Assembly Procedure

This section contains the information required to disassemble and assemble the Main Assembly.

Length Positioning Stage Assembly Removal:

1. Loosen the Length Locking Knob ("1" in [Table 4-3](#)).
2. Remove the Length Positioning Stage Assembly ("1" in [Table 4-2](#)).

Width Positioning Stage Assembly Removal:

1. Loosen each Width Positioning Knob ("1" in [Table 4-5](#)).
2. Remove each Width Positioning Stage Assembly ("3" and "4" in [Table 4-2](#)).
3. Remove the Device Stage ("2" in [Table 4-2](#)).

Replaceable Parts

Table 4-2 through **Table 4-5** show and list the replaceable parts for the 16192A and their respective RoHS compliant replacement support part. RoHS conversion involves with design and dimension change, which result in the RoHS support part backward incompatible with non-RoHS 16192A Parallel Electrode SMD Test Fixture. Special handling is needed while using the RoHS replacement part on non-RoHS 16192A. The original support part number is replaced by the respective “RoHS Compliant Replacement Part”. Once the original support part is depleted, please proceed to obtain the RoHS compliant support part.. The parts listed can be ordered from your nearest Keysight Technologies Office. Ordering information must include the Keysight part number and the quantity required.

Figure 4-2 Replaceable Parts for Main Assembly

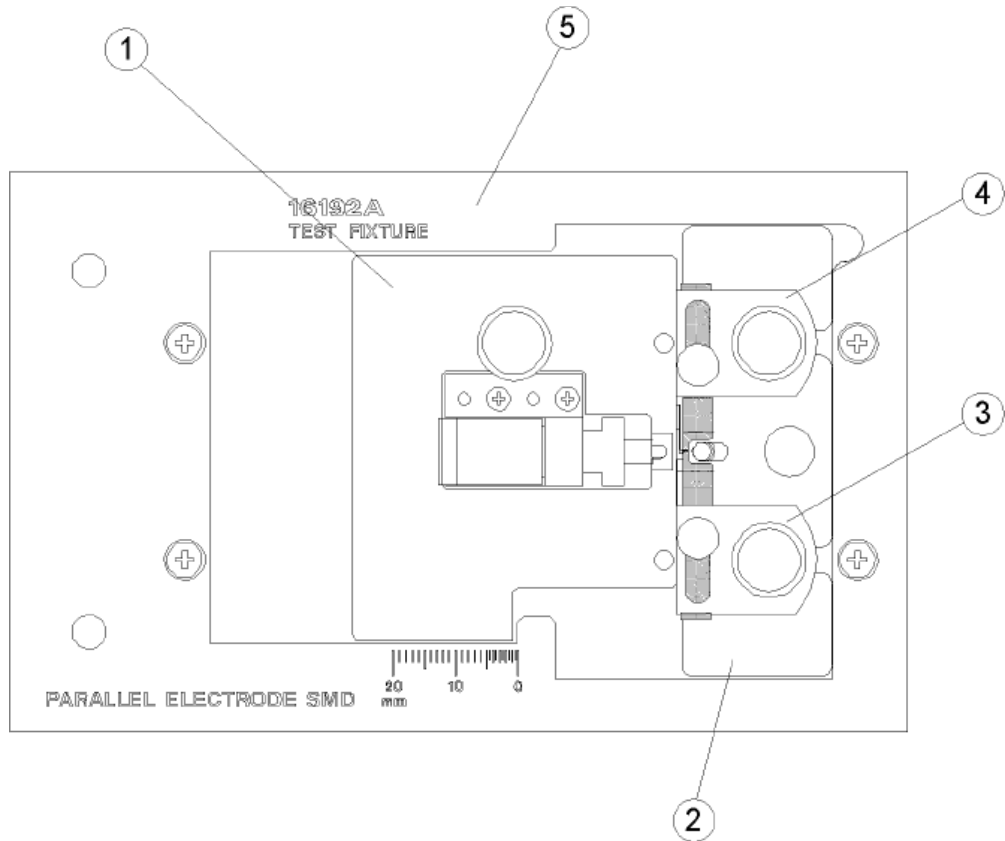

Table 4-2 Replaceable Parts for Main Assembly

Reference Designator	Keysight Part Number	RoHS Compliant Replacement Part Number	Qty	Description
1	(not assigned)	(not assigned)	1	Length Positioning Stage Assembly
2	16192-09001	16192-09001	1	Device Stage
3	(not assigned)	(not assigned)	1	Width Positioning Stage Assembly
4	(not assigned)	(not assigned)	1	Width Positioning Stage Assembly
5	(not assigned)	(not assigned)	1	Test Stage Assembly

Figure 4-3 Replaceable Parts for Length Positioning Stage Assembly

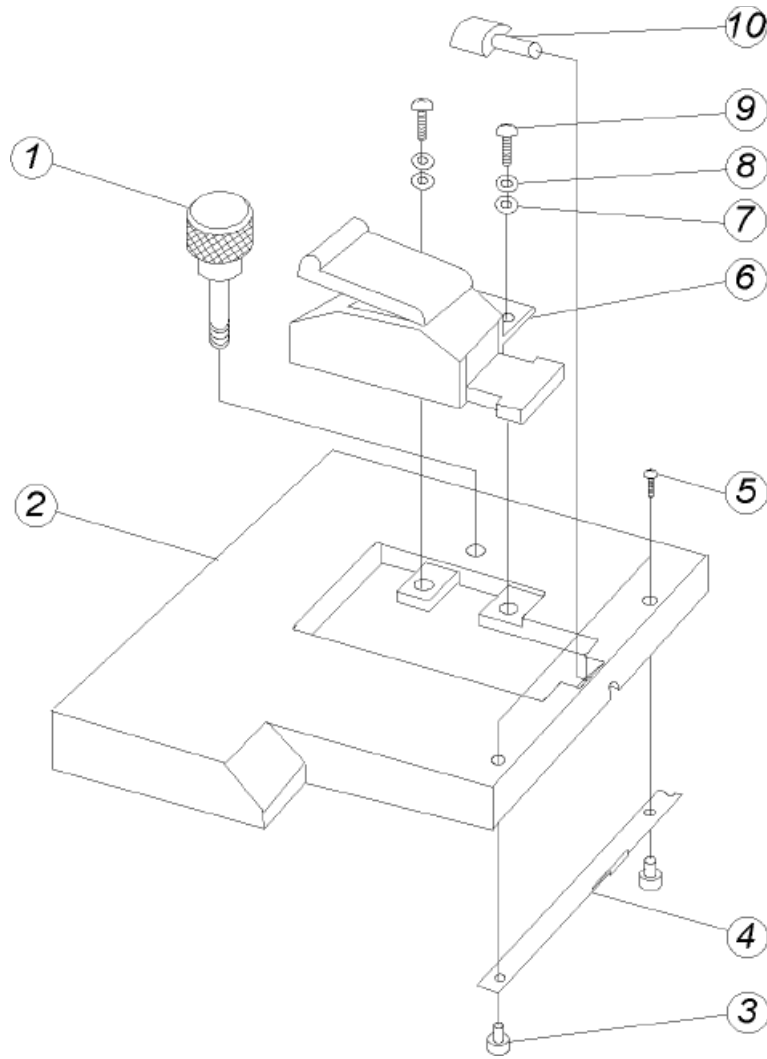

Table 4-3 Replaceable Parts for Length Positioning Stage Assembly

Reference Designator	Keysight Part Number	RoHS Compliant Replacement Part Number	Qty	Description
1	16192-24006	16192-24006	1	Length Locking Knob
2	16192-20002	16192-20002	1	Length Positioning Stage Block
3	16192-23001	16192-23001	2	Nut
4	16192-01202	16192-01202	1	Contact
5	0515-2421	0515-5363	2	Screw M1.4L3
6	(not assigned)	(not assigned)	1	Insertion Clip Assembly

Table 4-3 Replaceable Parts for Length Positioning Stage Assembly (Continued)

Reference Designator	Keysight Part Number	RoHS Compliant Replacement Part Number	Qty	Description
7	3050-1066	3050-1066	2	Washer
8	2190-0654	_1	2	Washer
9	0515-0976 (0515-2727)	0515-0658	2	Screw Pan Head M2L6
10	16192-25004	16192-25004	1	Rod

1. Not used in ROHS product model.

Figure 4-4 Replaceable Parts for Insertion Clip Assembly

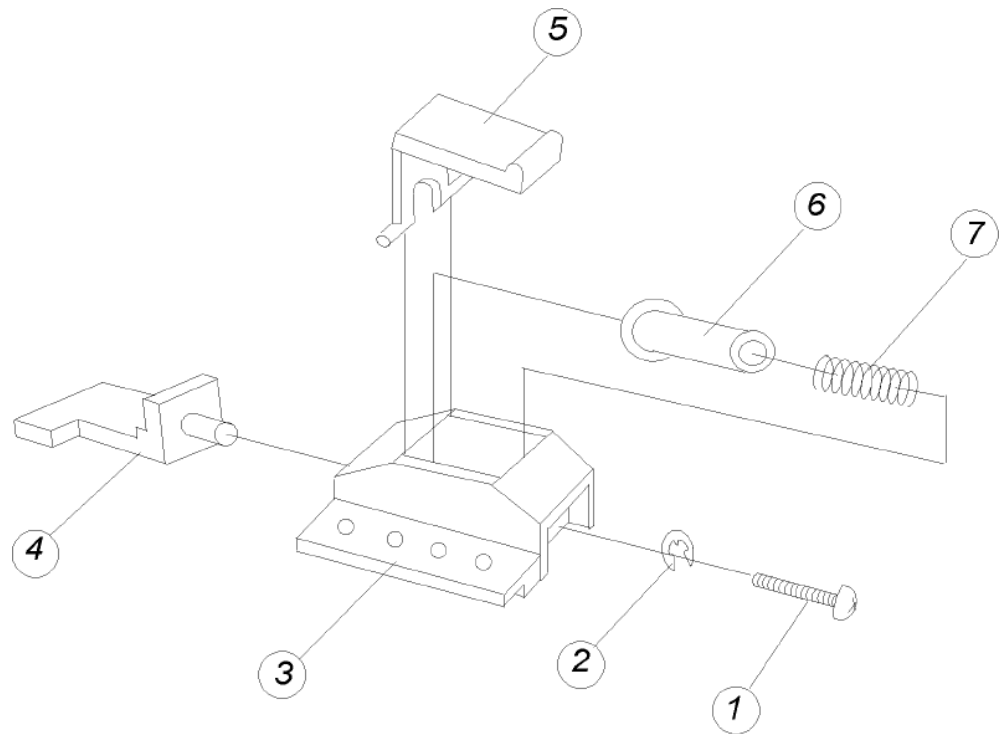

Table 4-4 Replaceable Parts for Insertion Clip Assembly

Reference Designator	Keysight Part Number	RoHS Compliant Replacement Part Number	Qty	Description
1	0520-0133	0515-0661 ¹	1	Screw

Table 4-4

Replaceable Parts for Insertion Clip Assembly (Continued)

Reference Designator	Keysight Part Number	RoHS Compliant Replacement Part Number	Qty	Description
2	2190-0014	3050-1066 ¹	1	Washer
3	16092-40010	16092-40010	1	Holder
4	16092-40016	16092-40616 ¹	1	Holder
5	16092-40011	16092-01201	1	Lever
6	16092-23010	16092-23010	1	Shaft
7	1460-0352	1460-0352	1	Spring

1. Set change. Replace all of the associated parts marked with <1> as they are mutually dependent.

Figure 4-5 Replaceable Parts for Width Positioning Stage Assembly

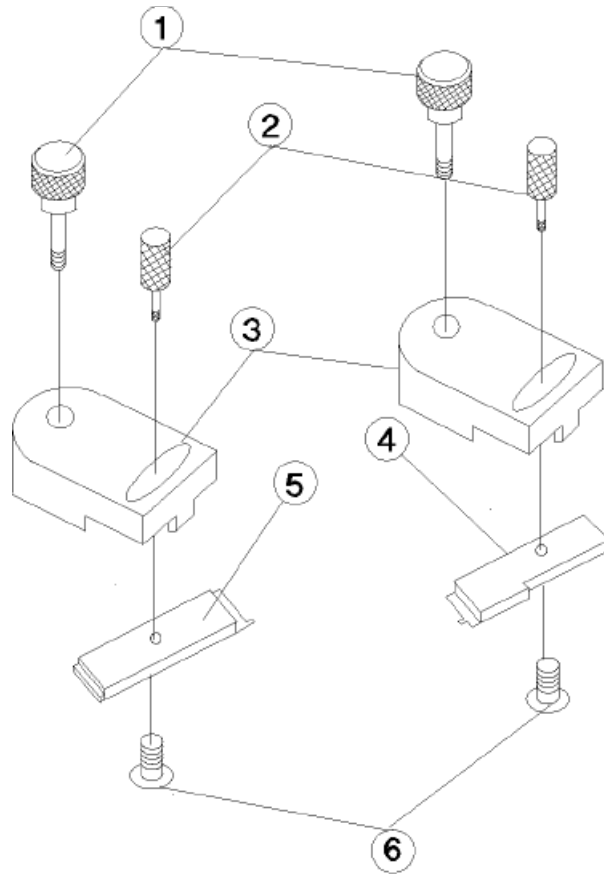

Table 4-5 Replaceable Parts for Width Positioning Stage Assembly

Reference Designator	Keysight Part Number	RoHS Compliant Replacement Part Number	Qty	Description
1	16192-24006	16192-24006	2	Width Positioning Knob
2	16192-24005	16192-24005	2	Device Holder Adjustment Knob
3	16192-24004	16192-24004	2	Holder
4	16192-25002	16192-25002	1	Device Holder L
5	16192-25003	16192-25003	1	Device Holder R
6	0515-0994	0515-1602	2	Screw Flat Head M2L6

Figure 4-6 Replaceable Parts for Test Stage Assembly

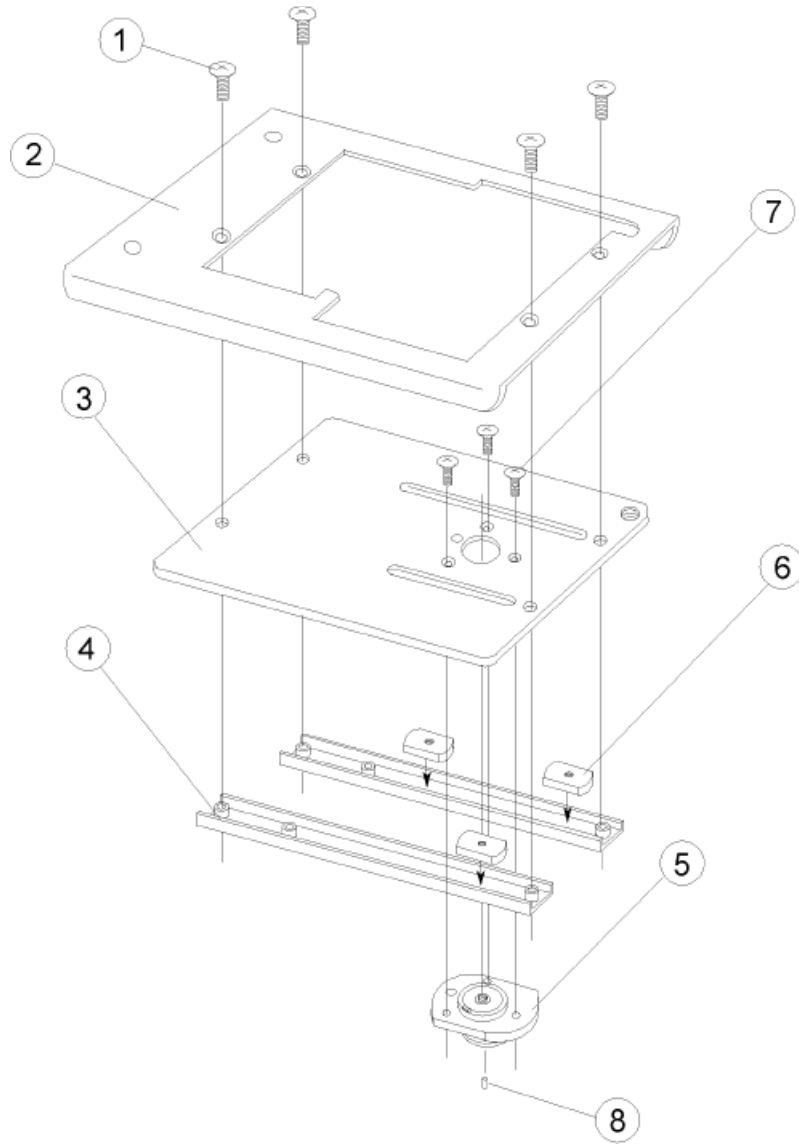

Table 4-6 Replaceable Parts for Test Stage Assembly

Reference Designator	Keysight Part Number	RoHS Compliant Replacement Part Number	Qty	Description
1	0515-0914	0515-1227	4	Screw Flat Head M3L6
2	16192-00201	16192-00201	1	Table
3	16192-00603	16192-00603	1	Plate
4	16192-01201	16192-01201	2	Angle

Table 4-6

Replaceable Parts for Test Stage Assembly (Continued)

Reference Designator	Keysight Part Number	RoHS Compliant Replacement Part Number	Qty	Description
5	16192-60001	16192-60001	1	Contact Assembly
6	16192-24013	16192-24013	3	Nut
7	0515-0952	0515-2151	3	Screw Flat Head M2L4
8	1250-0907	1250-0907	1	Contact-RF Connector

CAUTION

If your 16192A test fixture was manufactured earlier than 1996 and you need to replace either the plate (Figure 4-7: 3) or the contact assembly (Figure 4-7: 5), it will be necessary to buy replacements for both parts (Figure 4-6: 3 and 5) since they were modified at the same time. Neither of the new parts (Figure 4-6: 3 and 5) can be fitted to the other obsolete parts (Figure 4-7: 3 and 5).

Figure 4-7

Obsolete parts manufactured earlier than 1996

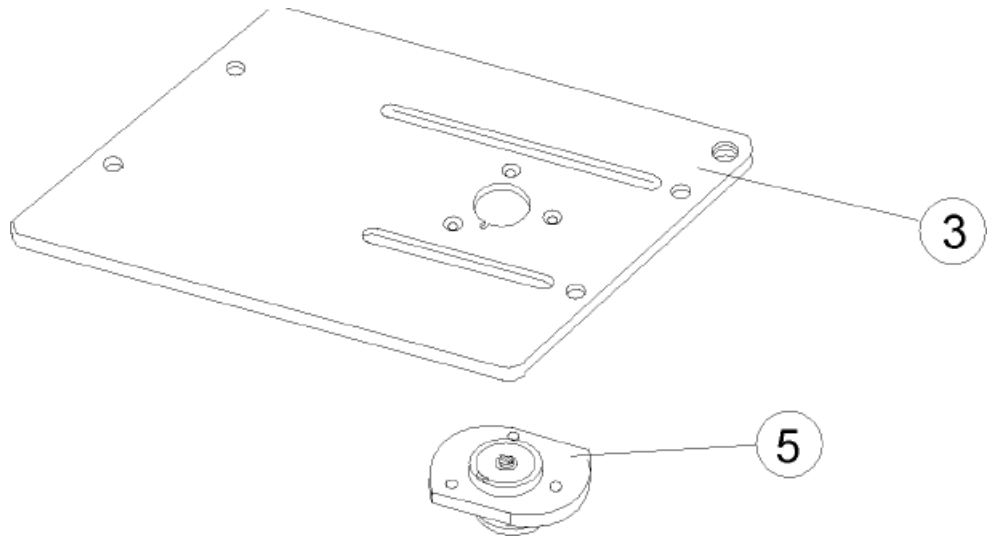

Troubleshooting

This section includes the functional check procedure used to troubleshoot the 16192A Parallel Electrode SMD Test Fixture.

Open Impedance Check

1. Adjust the electrode distance for connecting the 1×1×2.4 mm Shorting Device (PN 16191-29001). (Refer to **Figure 4-8.**)

Figure 4-8 Shorting Device Position

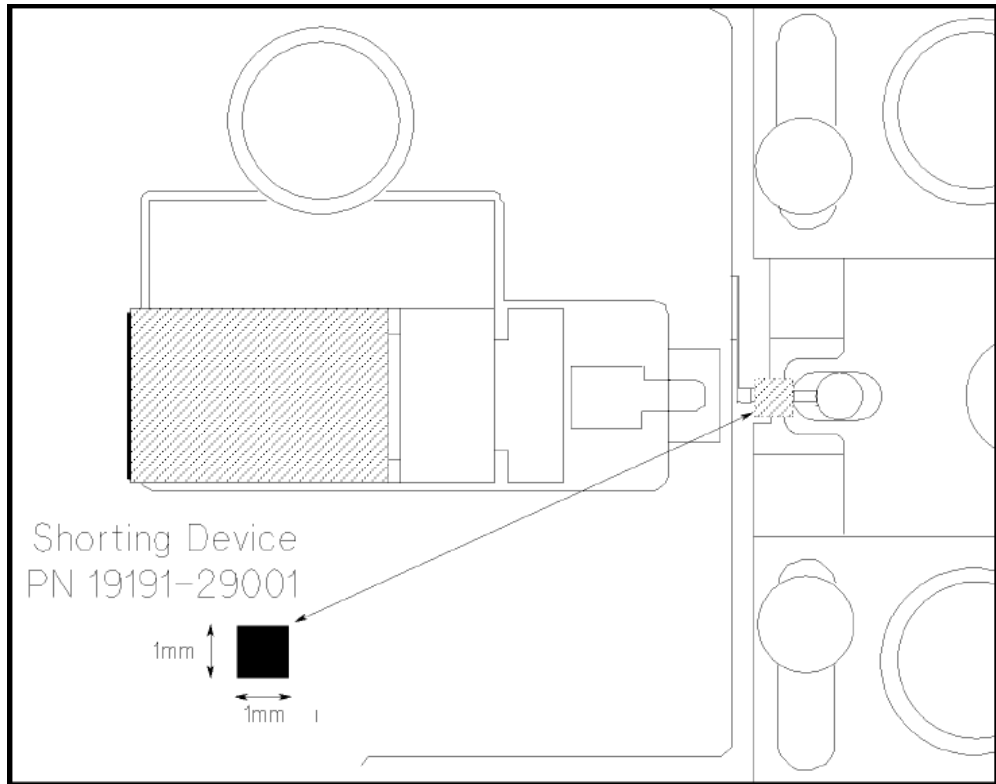

2. Place the fixture on the calibrated APC-7® terminal of the Impedance Analyzer.
3. Set the Impedance Analyzer as follows:

Measurement Parameter	Cp (parallel capacitance)
Start Frequency	100 MHz
Stop Frequency	1 GHz
OSC Level	0.12 V
Number of Point	2
Point Averaging Factor	16
Point Averaging	ON

4. Perform a single sweep measurement.
5. Read the Cp value at 100 MHz and 1 GHz.

The guideline for the open impedance value is as follows:

Table 4-7

Open Impedance Value Guideline

Parameter	Frequency	Guideline (Absolute Value)
Cp	100 MHz	750 fF ± 300 fF
Cp	1 GHz	750 fF ± 300 fF

Short Impedance Check

1. After the Open Impedance Check is completed, put the 1×1×2.4 mm Shorting Device (PN 16191-29001) between the electrodes (refer to **Figure 4-8**).
2. Set the Impedance Analyzer as follows:

Measurement Parameter	Ls (series inductance)
Start Frequency	100 MHz
Stop Frequency	1 GHz
OSC Level	0.12 V
Number of Point	2
Point Averaging Factor	16
Point Averaging	ON

3. Make a single sweep measurement.
4. Read Ls value at 100 MHz and 1 GHz.

The guideline of the short impedance value is as follows:

Table 4-8

Short Impedance Value Guideline

Parameter	Frequency	Guideline (Absolute Value)
Ls	100 MHz	4.5 nH ± 1.5 nH
Ls	1 GHz	4.5 nH ± 1.5 nH

Short Impedance Repeatability Check

1. After the Short Impedance Check is completed, remove the Shorting Device and put it back on the same place again (refer to [Figure 4-8](#)).
2. Make a single sweep measurement with the same measurement conditions.
3. Read Lp value at 100 MHz and 1 GHz and check the value is within the Short Impedance Value Guideline described in [Table 4-8](#).
4. Calculate the difference between the first Ls measurement value and second Ls measurement value at each frequency.

The guideline of the short impedance repeatability is as follows:

Table 4-9

Short Impedance Repeatability Guideline

Parameter	Frequency	Guideline (Difference)
Ls	100 MHz	± 45 pH
Ls	1 GHz	± 20 pH

This information is subject to change without notice.
© Keysight Technologies 1993 - 2019
Edition 8, August 26, 2019



16192-90040
www.keysight.com