

Up to 120 MHz (4-Terminal Pair): Material

16451B Dielectric test fixture

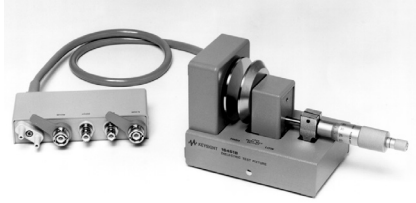

Terminal connector: 4-Terminal pair, BNC
Dimension (approx.): See page 26
Cable length (approx.):
 0.8 m (from connector to electrodes)
Weight (approx.): 3700 g
Measurement accuracy

$$\epsilon' \text{ accuracy } \left(\frac{\Delta \epsilon'_{rm}}{\epsilon'_{rm}} \right)$$

$\tan \delta < 0.1$:

$$A_z + 0.04 f^2 \epsilon'_{rm} \epsilon_0 \left(\frac{\pi \left(\frac{d}{2} \right)^2}{t} \right) + \frac{100 (\epsilon'_{rm} - 1)}{(\epsilon'_{rm} - \frac{t}{0.01})} [\%]$$

ϵ^* Loss Tangent Accuracy ($\Delta \tan \delta$)
 $\tan \delta < 0.1$: Ad + Ea + Eb

$$E_a = 0.005 + 0.0004 f^2 \epsilon'_{rm} \epsilon_0 \left(\frac{\pi \left(\frac{d}{2} \right)^2}{t} \right)$$

$$E_b = \frac{\tan \delta}{100} \frac{\Delta \epsilon'_{rm}}{\epsilon'_{rm}}$$

(supplemental performance characteristics):

f: measured frequency [Hz] $f \leq 30$ MHz

ϵ'_{rm} : measured permittivity

$\tan \delta$: measured dissipation factor

ϵ_0 : permittivity of air 8.854×10^{-12} [F/m]

d: diameter of electrode {A,B}

t: thickness of material [mm]

A_z : Impedance measurement error of instrument

Ad: D measurement error of instrument

The material is assumed to be ideally flat.

The above equation is applicable for electrodes A and B when using the contacting electrode method.

Description: The 16451B is used to evaluate the dielectric constant of solid dielectric materials accurately, and complies with ASTM D150. The 16451B employs the parallel plate method, which sandwiches the material between two electrodes to form a capacitor. LCR meter or an Impedance Analyzer is then used to measure the capacitance created from the fixture. A measurement block diagram of the parallel plate method is shown below:

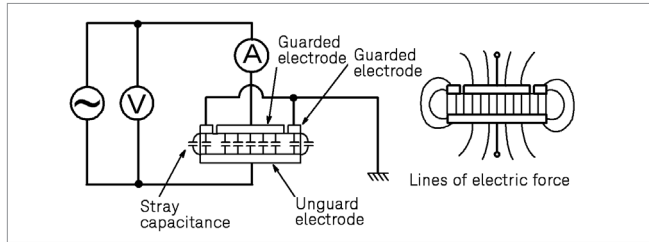

Parallel plate method

Notice the stray capacitance, which is formed on the test material as shown in the figure above. The guard electrode helps to eliminate the stray capacitance at the edge of the electrode.

Basic measurement accuracy (including the E4990A):

Typical Permittivity (ϵ') Measurement Accuracy:

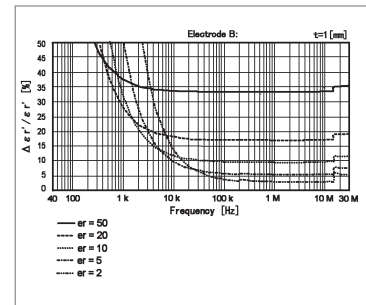
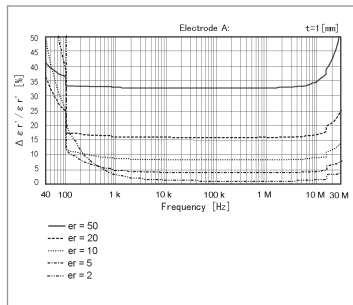

Typical Loss Tangent ($\tan \delta$) Measurement Accuracy:

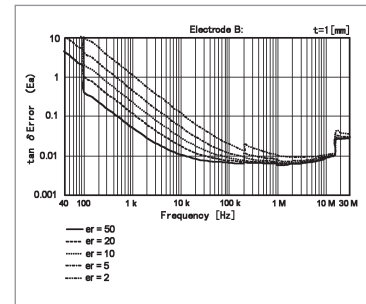
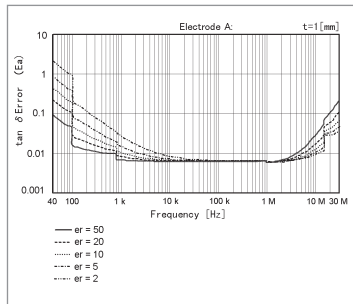

E4990A Measurement settings;

1. Osc level : 500 mV
2. Meas Time: 5 Precise
3. Adapter setup : 1 m
4. Compensation : Open, short and load

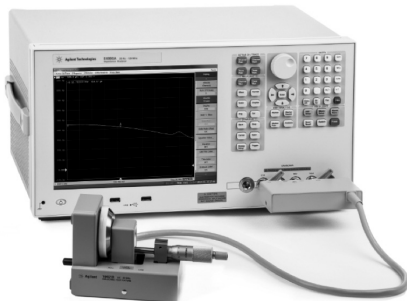

E4990A with 16451B



Up to 120 MHz (4-Terminal Pair): Material *continued*

16451B Dielectric test fixture *continued*

Applicable instruments: E4980A/AL, E4981A, E4990A

Frequency: DC to 30 MHz

Maximum voltage: ±42 V peak max. (AC+DC)

Operating temperature: 0 to 55°C

Material size:

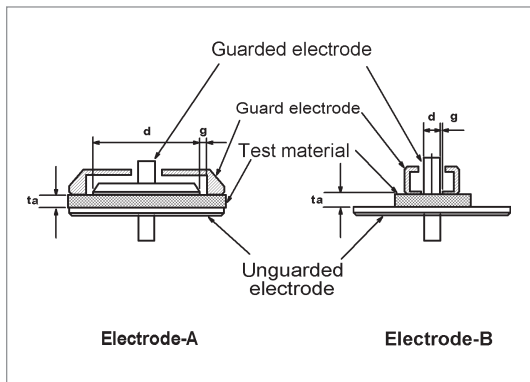

Electrodes for contacting electrode method (Rigid Metal Electrode)

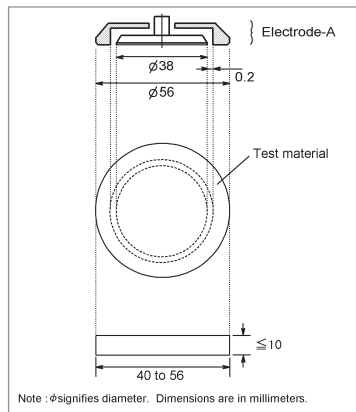

Material size for electrode-A

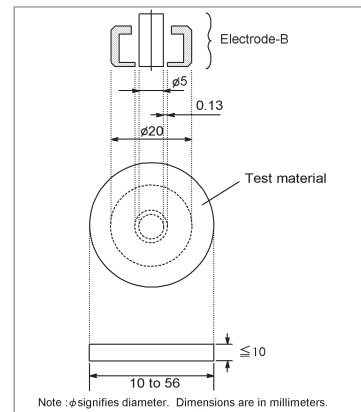

Material size for electrode-B

Equipped with Electrodes A and B for flat and smooth materials.

Electrode type	Diameter of MUT	Thickness of MUT	Diameter of electrode	Max. frequency
A	40 mm ~ 56 mm	$t \leq 10$ mm	38 mm	30 MHz
B	10 mm ~ 56 mm	$t \leq 10$ mm	5 mm	30 MHz

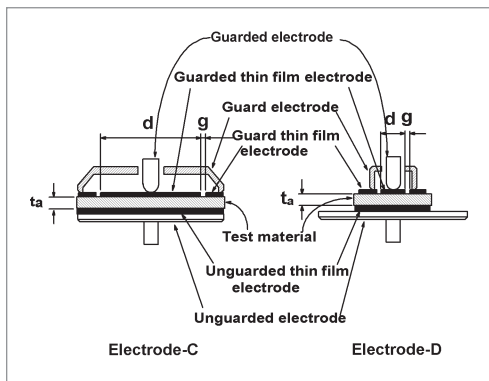

Electrodes for contacting electrode method (Thin Film Electrode)

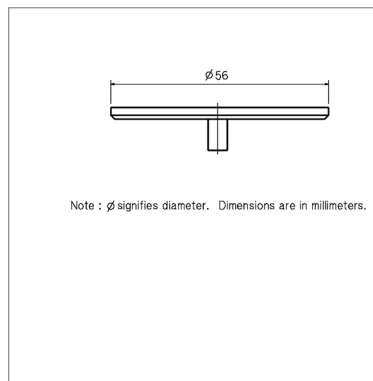

Material size for electrode-C

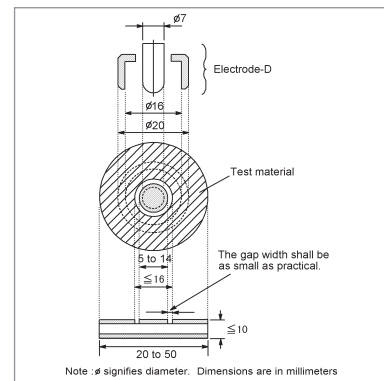

Material size for electrode-D

Equipped with Electrodes C and D for rough or extremely thin materials.

Electrode type	Diameter of MUT	Thickness of MUT	Diameter of electrode	Max. frequency
C	56 mm	$t \leq 10$ mm	5 ~ 50 mm	30 MHz
D	20 mm ~ 56 mm	$t \leq 10$ mm	5 ~ 14 mm	30 MHz

* diameter of applied thin film electrode



Up to 120 MHz (4-Terminal Pair): Material *continued*

16451B Dielectric test fixture *continued*

Furnished accessories:

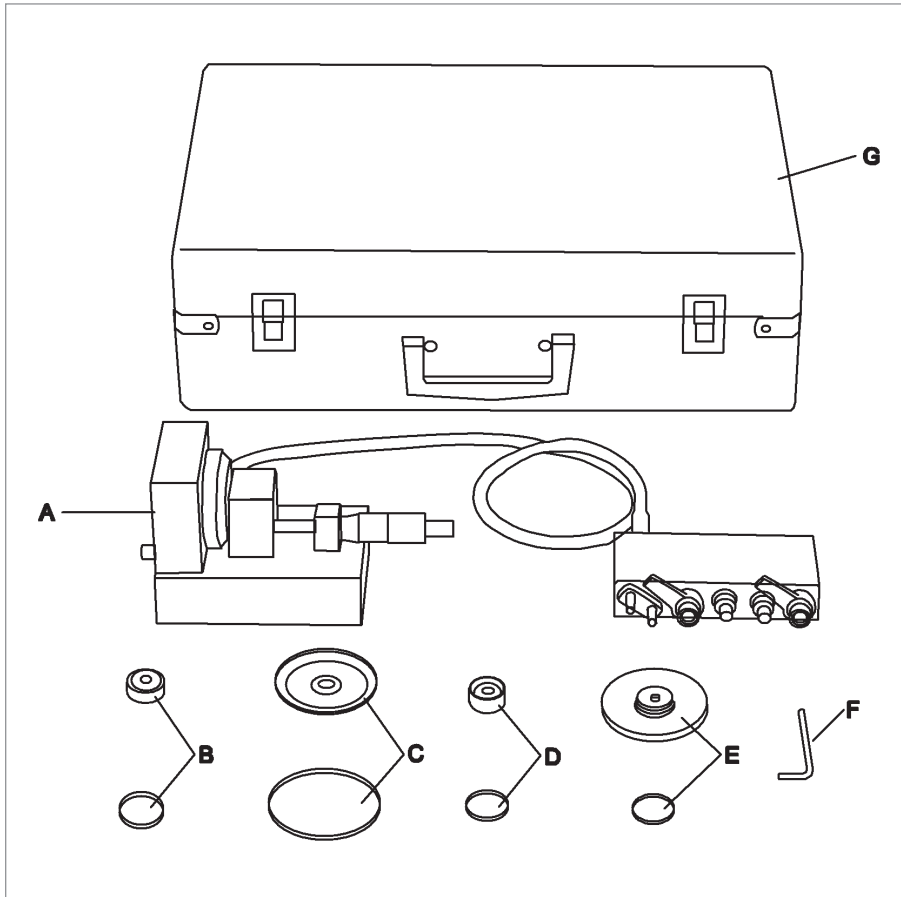

Description	P/N	Qty.	
Test Fixture including Electrode-A, unguarded electrode and cover	N/A	1	A
Electrode-B and cover	16451-60013	1	B
Electrode-C and cover	16451-60012	1	C
Electrode-D and cover	16451-60014	1	D
Attachment for error compensation and cover	16451-60021	1	E
Hex key (for replacing electrodes)	5188-4452	1	F
Carrying Case	16451-60001	1	G

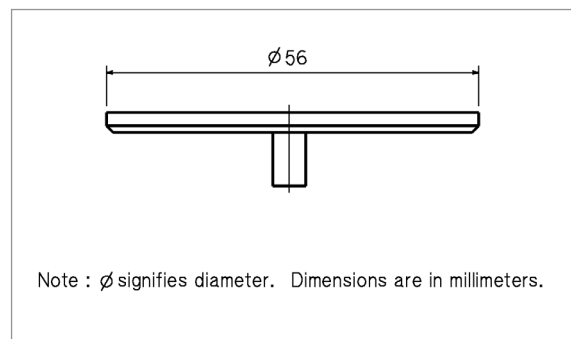

Dimensions of unguarded electrode

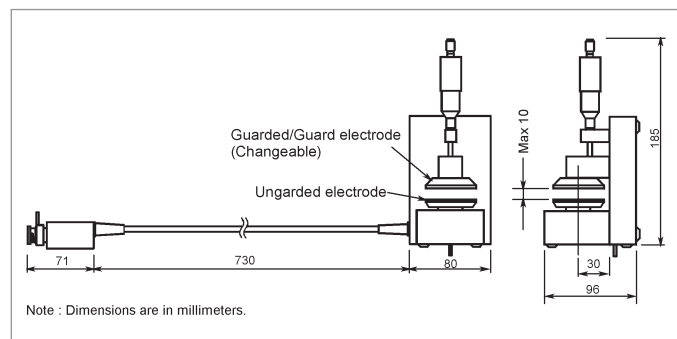

Dimensions of fixture assembly



Up to 120 MHz (4-Terminal Pair): Material *continued*

16451B Dielectric test fixture *continued*

Compensation and measurement: There are three measurement methods for the 16451B. They are the Contacting Electrode Method (used with 16451B's rigid metal electrode, without any electrodes on the material under test), the Contacting Electrode Method (used with thin film electrodes made on the material under test), and the Non-Contacting Electrode (Air Gap method). Select the suitable measurement method and the suitable electrode for the material under test according to the following table.

Summary of measurement method

Measurement method	Contacting electrode method (used with rigid metal electrode)	Contacting electrode method (used with thin film electrode)	Non-contacting electrode method
Accuracy	Low		-----> High
Operation	Simple		-----> Complex
Applicable materials	Thick, solid and smooth materials	Materials on which thin film can be applied without changing its characteristics	Thick, and soft materials Rough materials also

Open and short compensations are recommended in combination with the cable length compensation before measurement. When measuring above 5 MHz with the E4990A, load compensation is also recommended. First, set the instrument's cable length compensation function to 1 m. Then, open and short compensation is performed by using the furnished electrode attachment. Load compensation is performed, by preparing a working standard. After performing open, short and load compensations, the MUT is sandwiched by the parallel electrodes and the capacitance is measured. Relative permittivity is calculated from the measured capacitance in the following manner:

$$\epsilon_r' = \frac{t_a \times C_p}{\pi \times \left(\frac{d}{2}\right)^2 \times \epsilon_o}$$

ϵ_r' : Relative permittivity

C_p : Capacitance (measurement data)

ϵ_o : 8.854×10^{-12} [F/m]

t_a : Average thickness of test material

d : Diameter of guarded electrode

