



BRETFORD

LAP18EBA

LAP18EFR

NOTEBOOK CART ASSEMBLY

Assembly Instructions for:
INTERIOR E-UNIT
REPOSITIONING / REPLACEMENT
AND
TIMER INSTALLATION

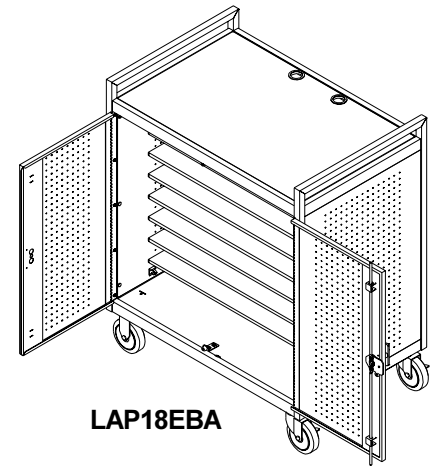

LAP18EBA

CAUTION: RISK OF ELECTRICAL SHOCK.
DO NOT PLUG INTO ANOTHER
RELOCATABLE POWER TAP.

Parts List

Qty.	Part No.	Description
1	LAP18EBA	Cart Assembly, e-units at back
	LAP18EFR	Cart Assembly, e-units at front

Tools Required

Philips screwdriver

**MAXIMUM WEIGHT OF ACCESSORIES
ON TOP OF CART: 25 LBS.**

NOTE:

**UNPLUG CART POWER CORDS FROM
POWER SOURCE BEFORE STARTING**

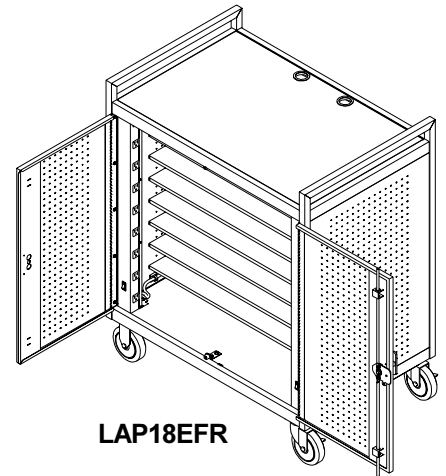

LAP18EFR

**E-UNIT REPOSITIONING:
'FRONT TO REAR'**

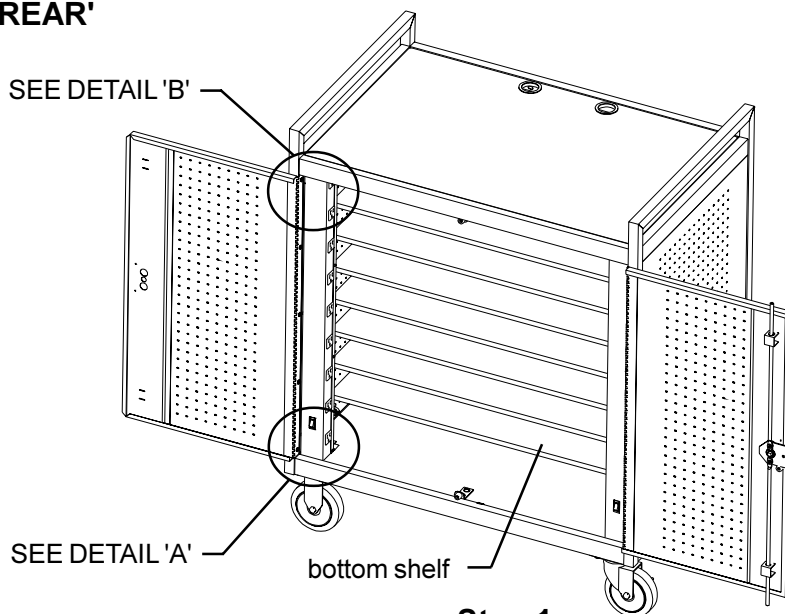

Step 1

Open both front doors of cart to access E-Units. Unwind any length of E-Unit power cord remaining on the back panel cord wrap brackets. Unclip the power cords from the side panel clips (see DETAIL 'A'). Loosen the screw holding the E-Unit bracket assembly and remove all 4 bracket assemblies (see DETAILS 'A' and 'B').

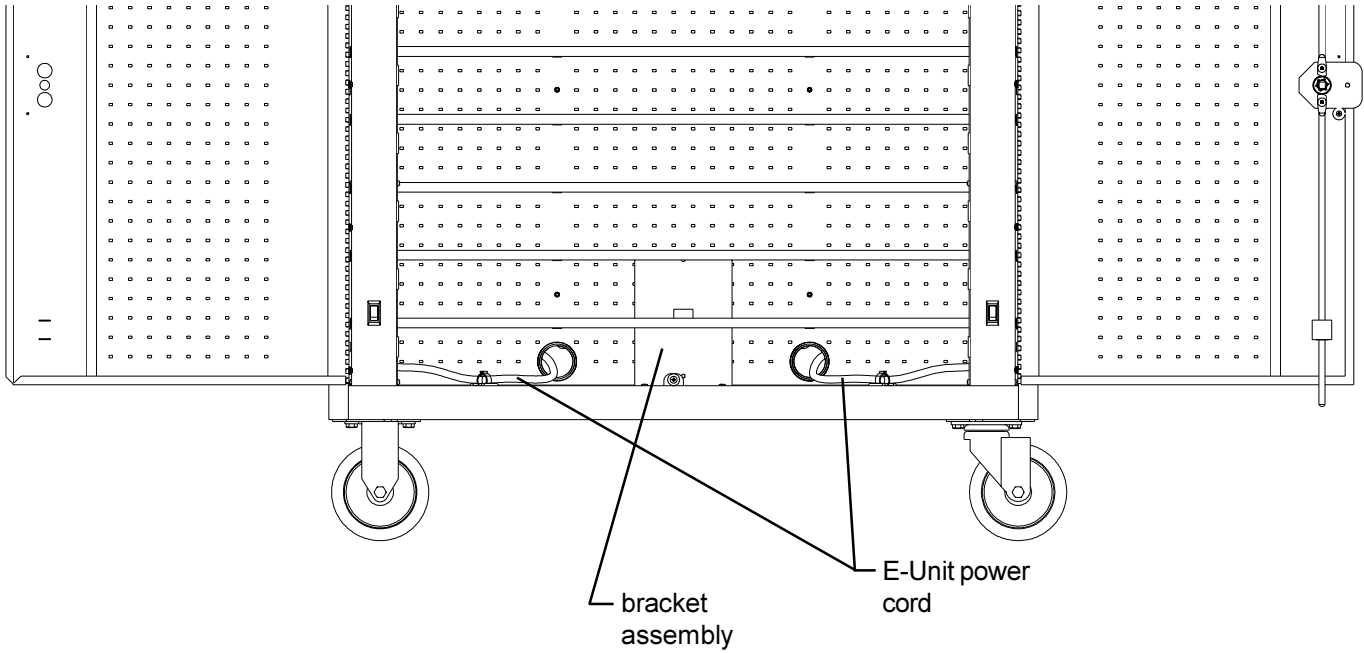

Front View

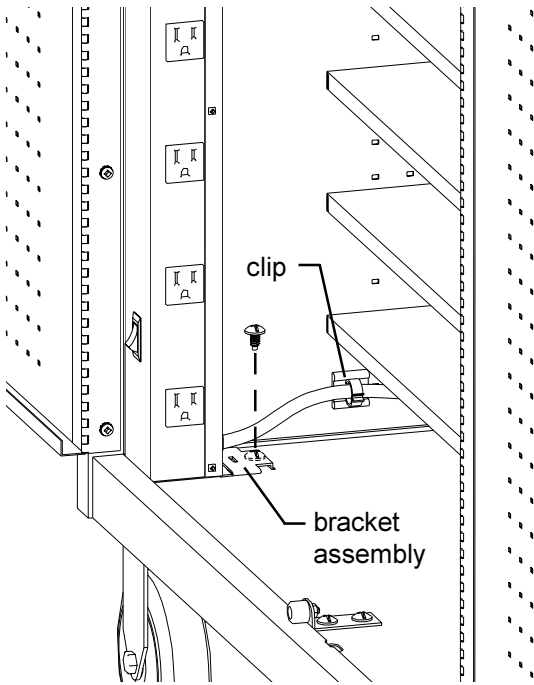

DETAIL 'A'

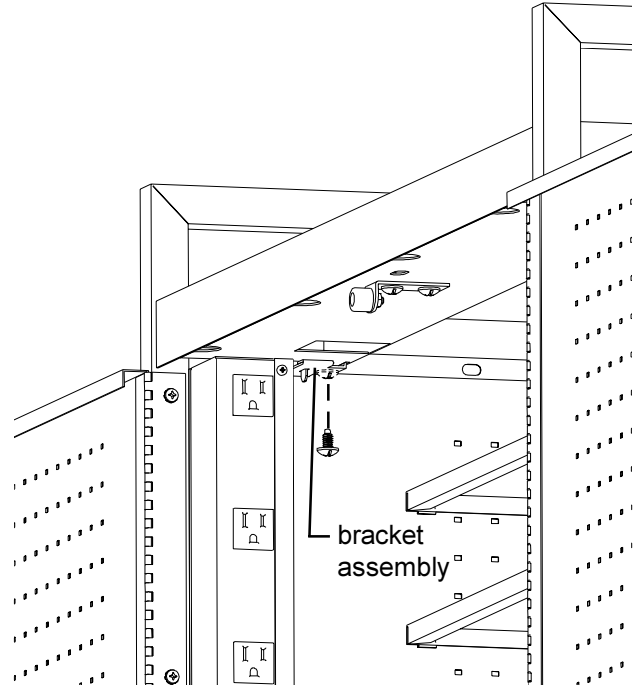

DETAIL 'B'

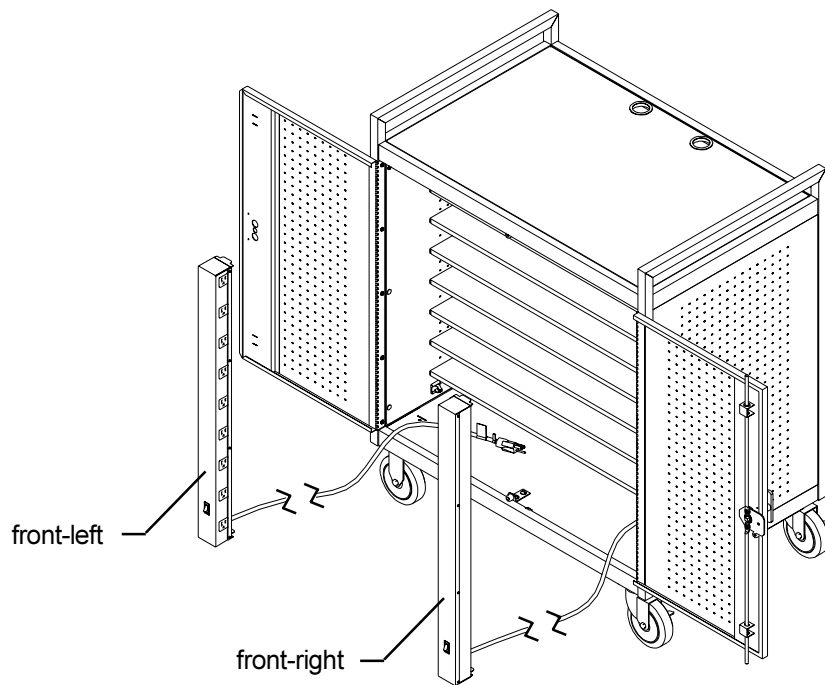

Step 2

Remove **front-left** E-Unit by gripping the top and tilt it side ways until it clears the underside of the cart interior shelf channel and set it aside.

Remove **front-right** E-Unit by gripping the top and tilt it side ways until it clears the underside of the cart interior shelf channel and set it aside.

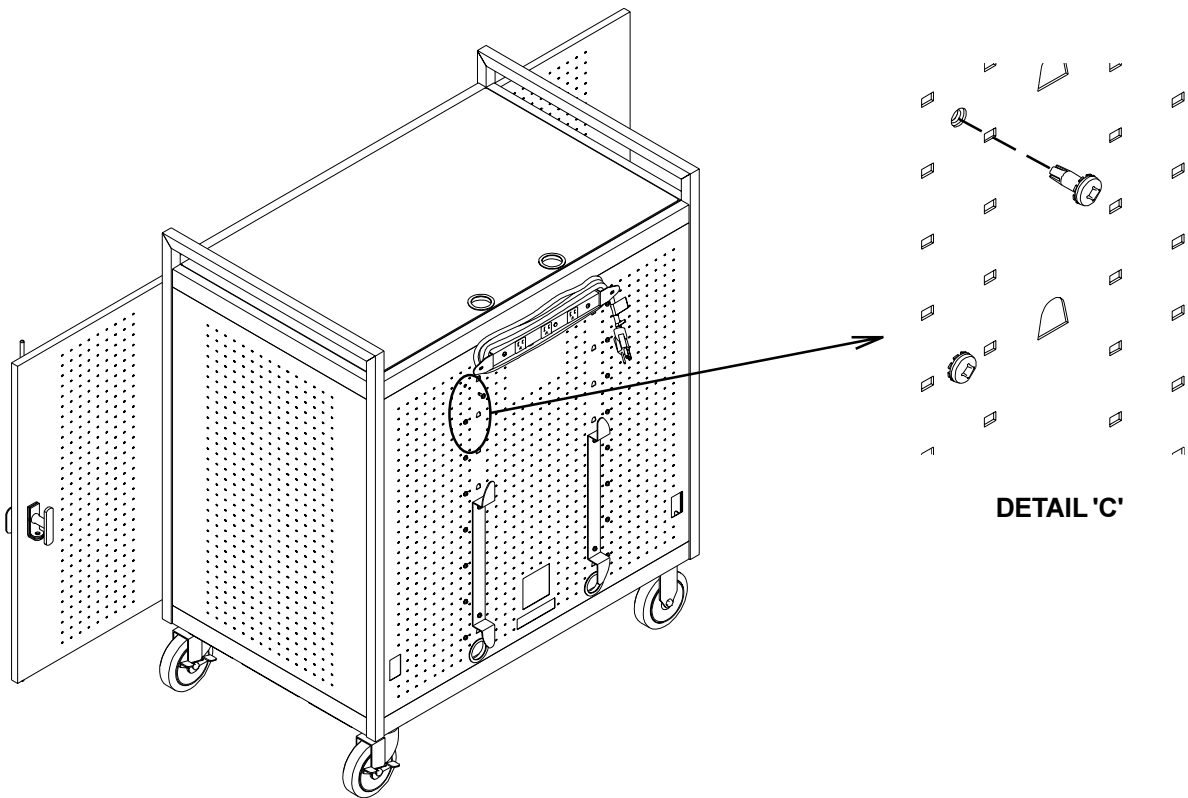

Step 3

Remove 16 screws (2 per shelf) from rear panel that secure the 8 interior shelves (see DETAIL 'C').

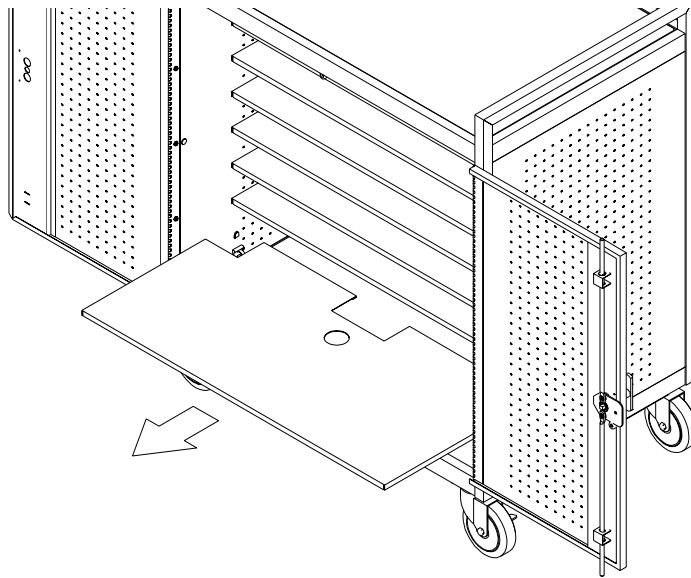
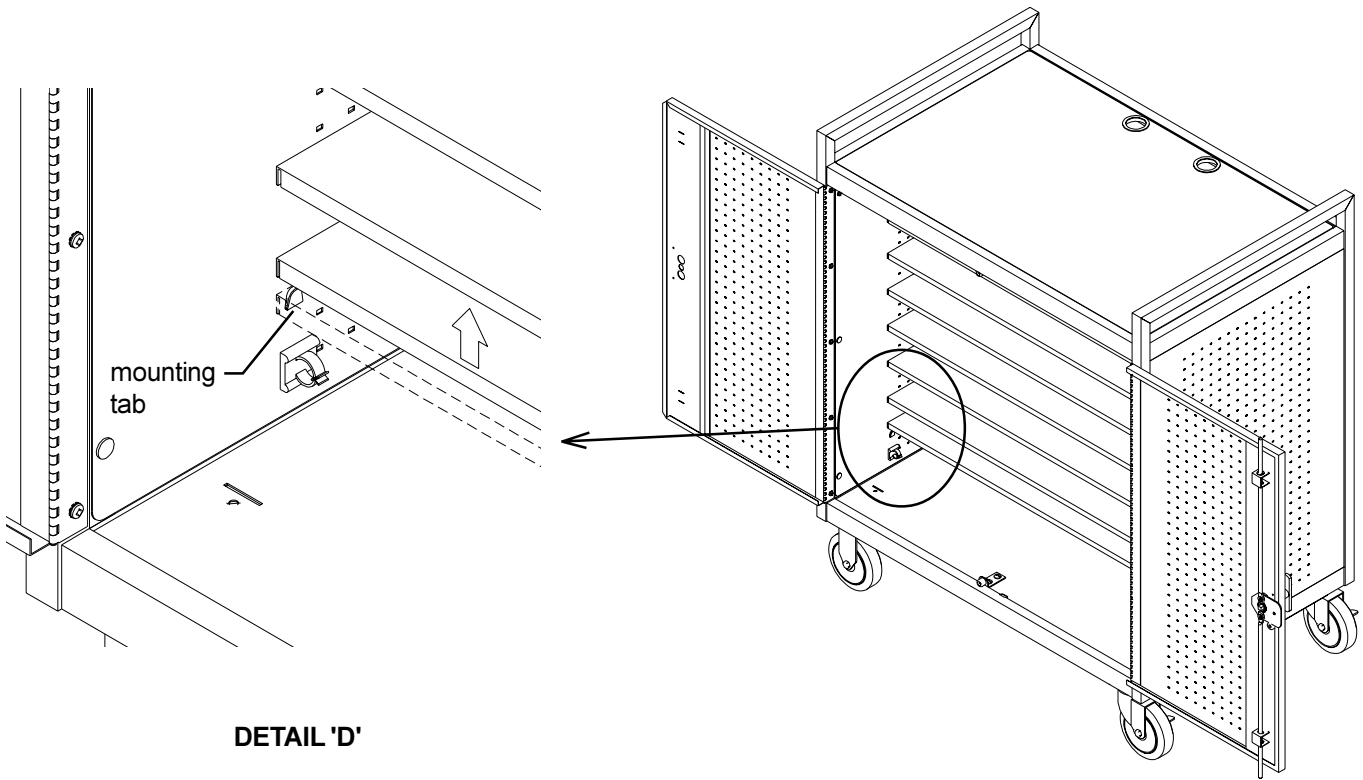

Step 4

Remove each interior shelf by carefully pushing upward (to release shelf from mounting tabs) shown in Detail 'D', then carefully sliding out. Set each shelf aside.

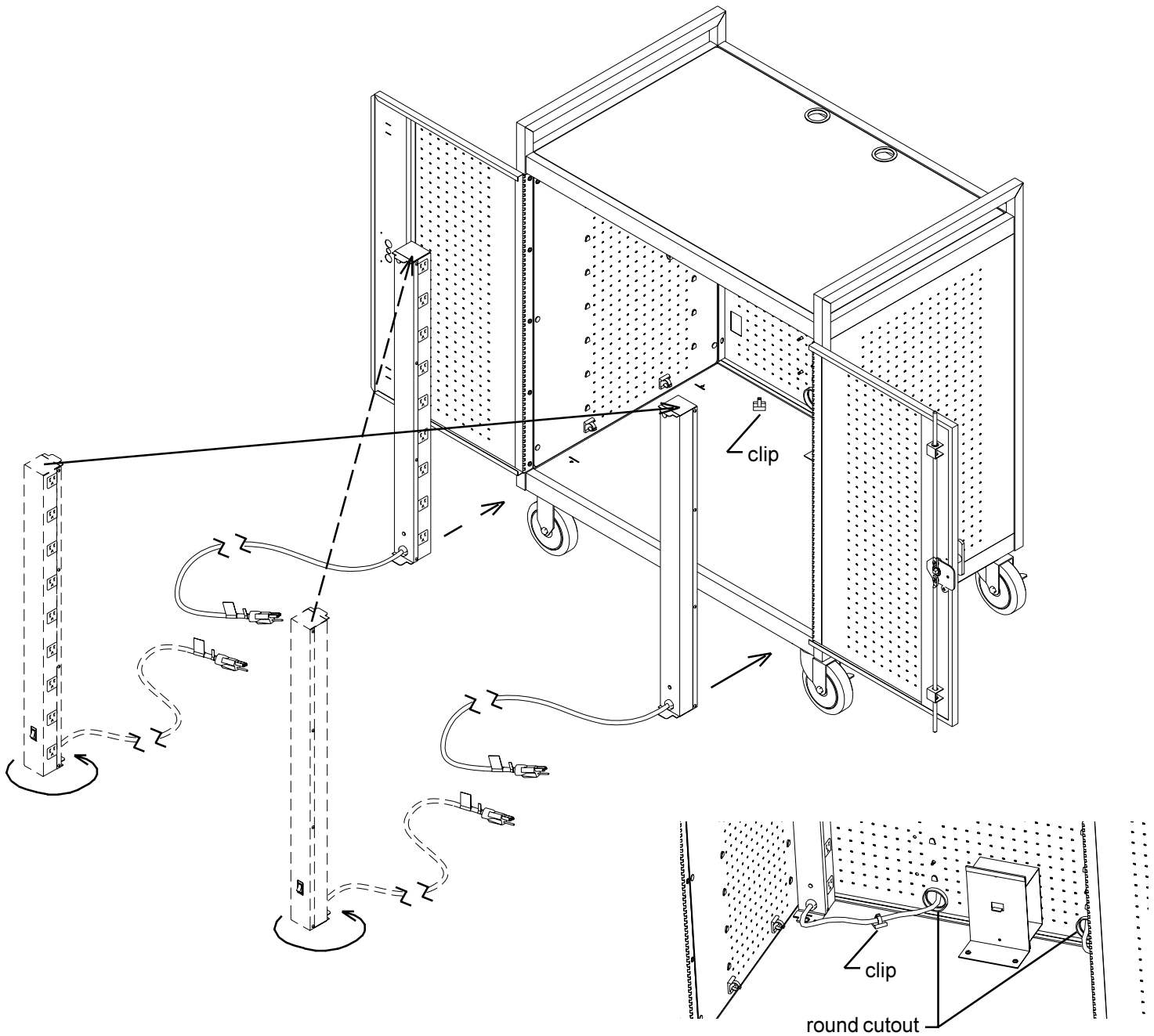

Figure 1

Step 5

Reinstall the E-Units (set aside from being removed from the front) as follows:

1. Rotate the E-Unit 180 degrees (from original position).
2. Cross over to opposite corner of cart.
3. Tilt in and set bottom in back corner.
4. Grip the top and tilt to the upright position.

When repositioned correctly, the E-Unit outlets face the interior and power switch should be visible from rear panel cutout.

Reinstall the E-Unit bracket assemblies (make sure that the top flange of the E-unit is aligned with the slot in the bracket assembly) and tighten screws securely.

Feed the power cords (plug end) all the way through the bottom rear round cutout (next to the bracket assembly) shown in Figure 1.

Press each E-Unit power cord into the single wire clip located at the rear/bottom of the cart only. Wind power cords around the cord wrap bracket located above each round cutout for storage.

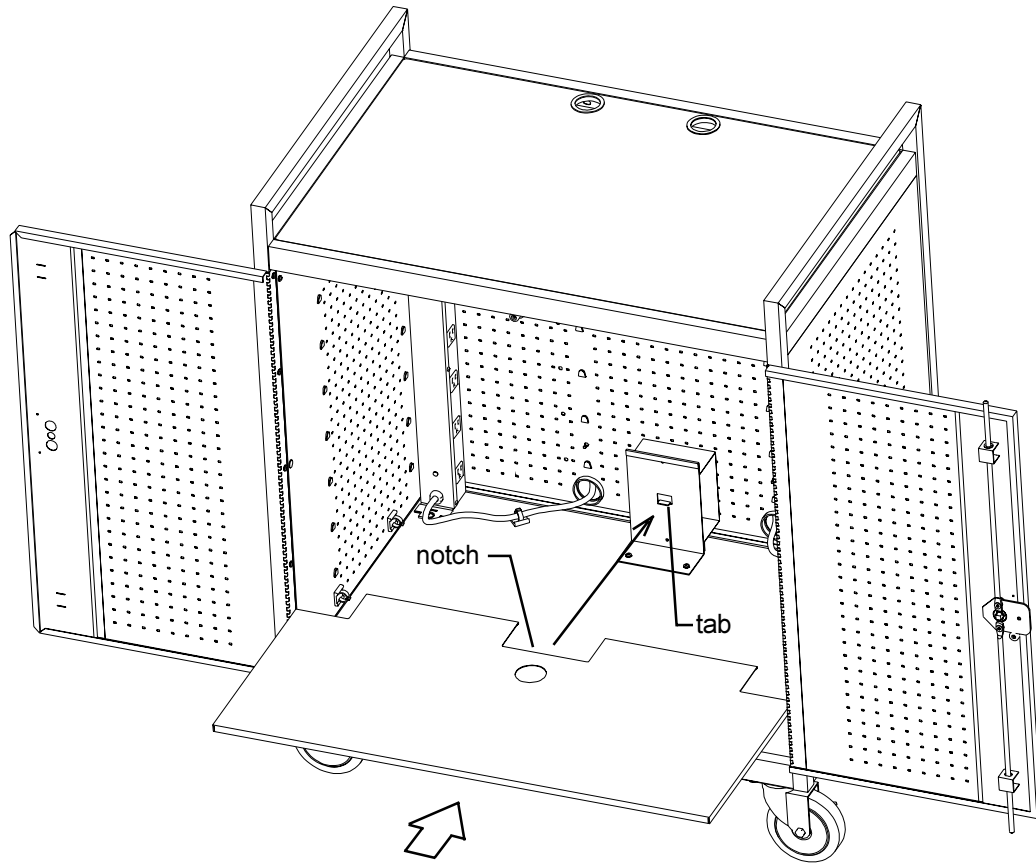

Step 6

Reinstall the 8 interior shelves as follows:

1. Carefully slide in the shelf with notch at the **bottom** position (the notch will rest on the bracket tab).
(Make sure that the shelf flanges are ALL seated into the mounting tabs.)
2. Slide in all remaining shelves into position as the bottom shelf.

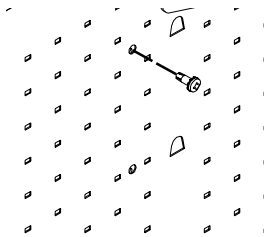
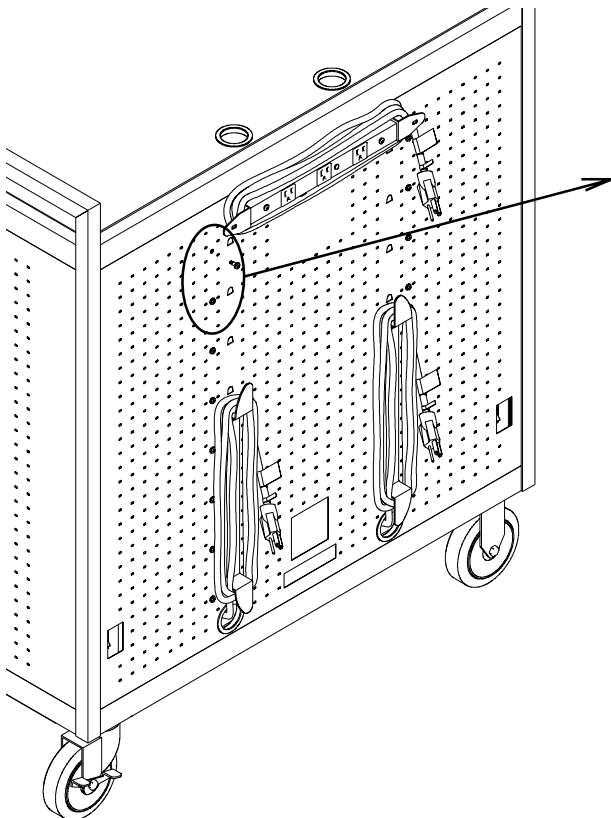

DETAIL 'E'

Step 7

Reinstall 16 screws to rear panel that will secure the 8 interior shelves (see DETAIL 'E'). **DO NOT OVER TIGHTEN SCREWS.**

Installation is now complete and ready for use.

NOTE:
UNPLUG CART POWER CORDS FROM
POWER SOURCE BEFORE STARTING

E-UNIT REPOSITIONING:
'REAR TO FRONT'

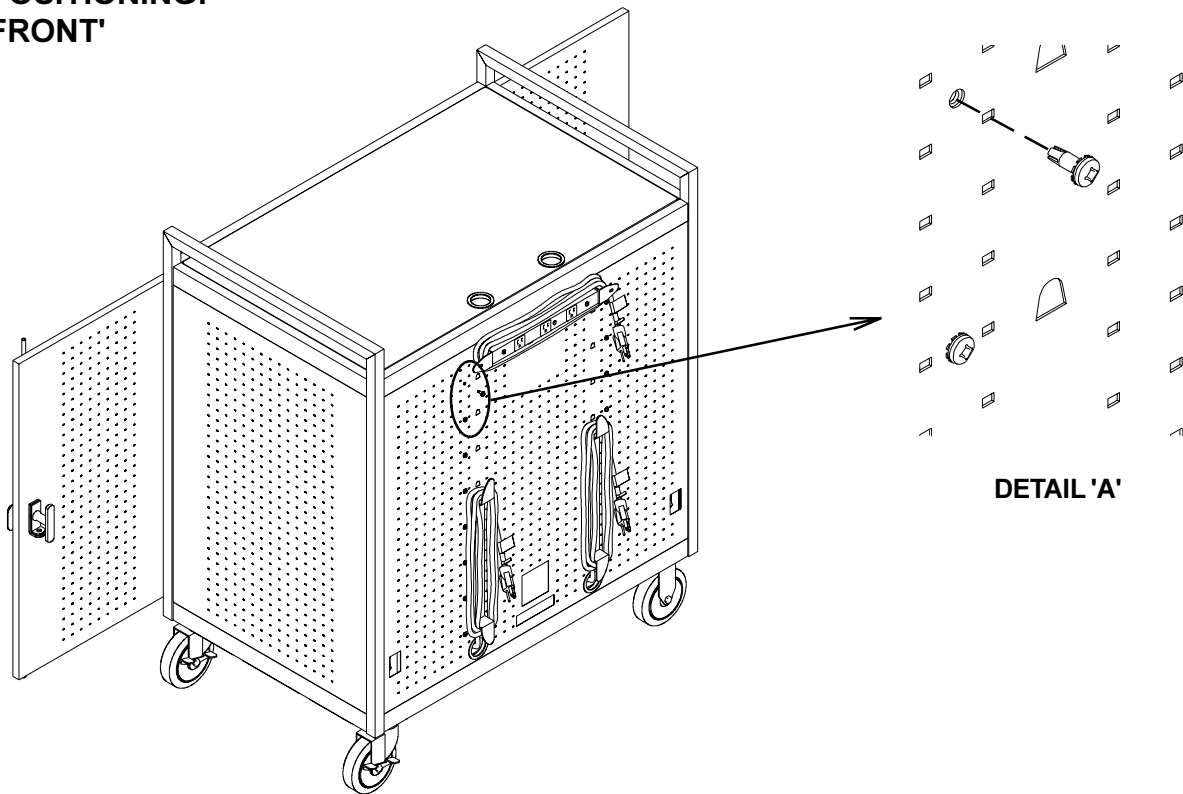

Step 1

Remove 16 screws (2 per shelf) from rear panel that secure the 8 interior shelves (see DETAIL 'A').

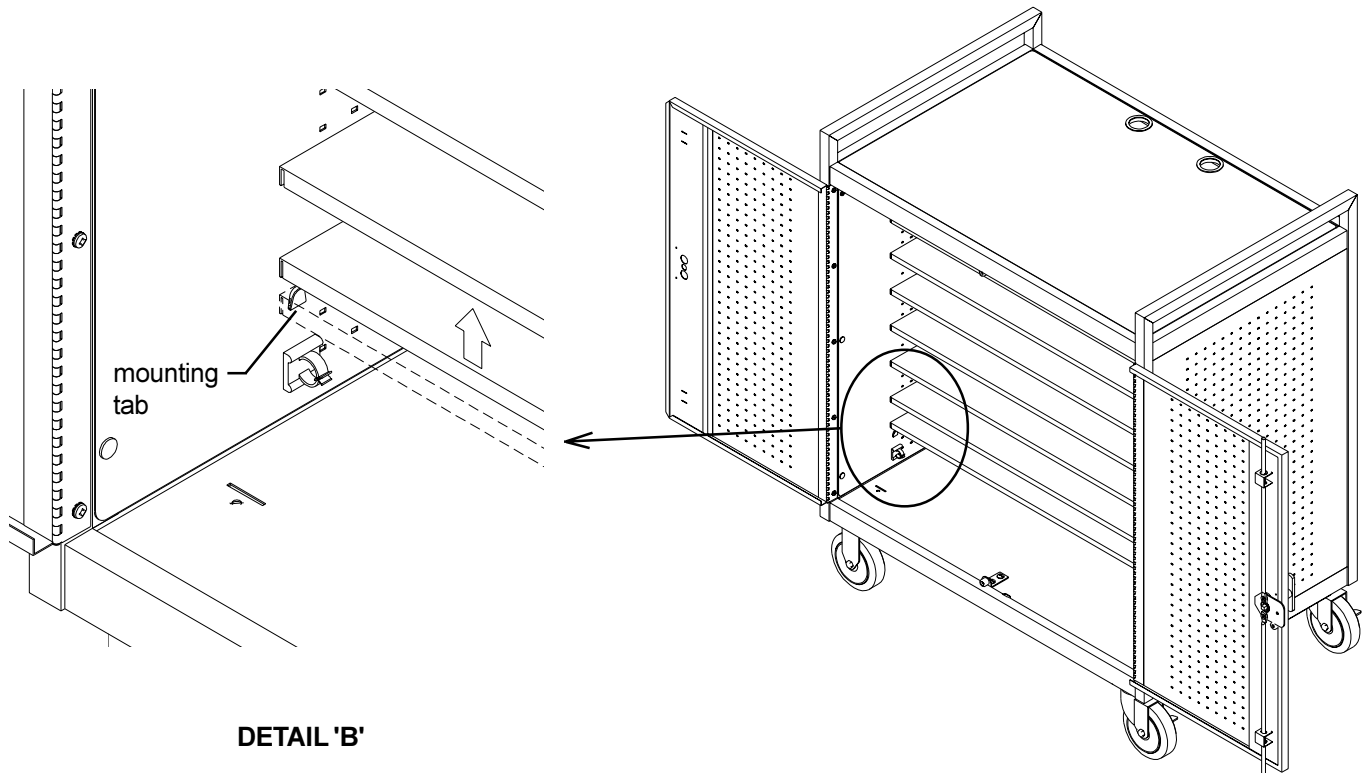

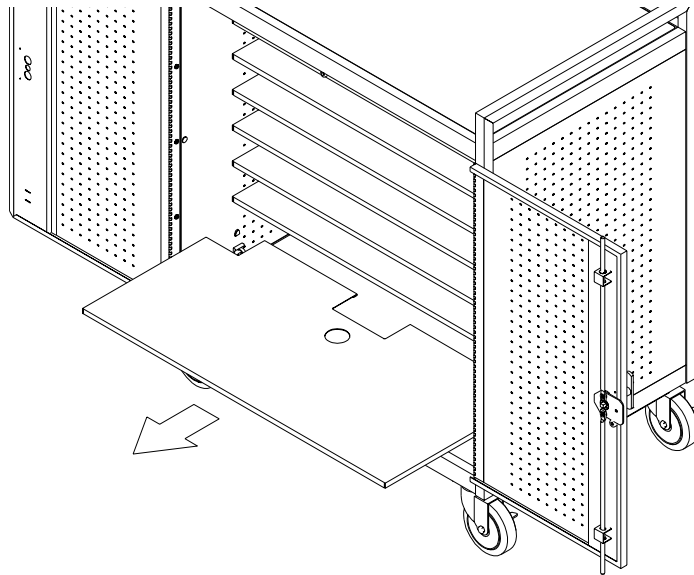

Step 2

With both doors open, remove each interior shelf by carefully pushing upward (to release shelf from mounting tabs) shown in Detail 'B', then carefully sliding out. Set each shelf aside.

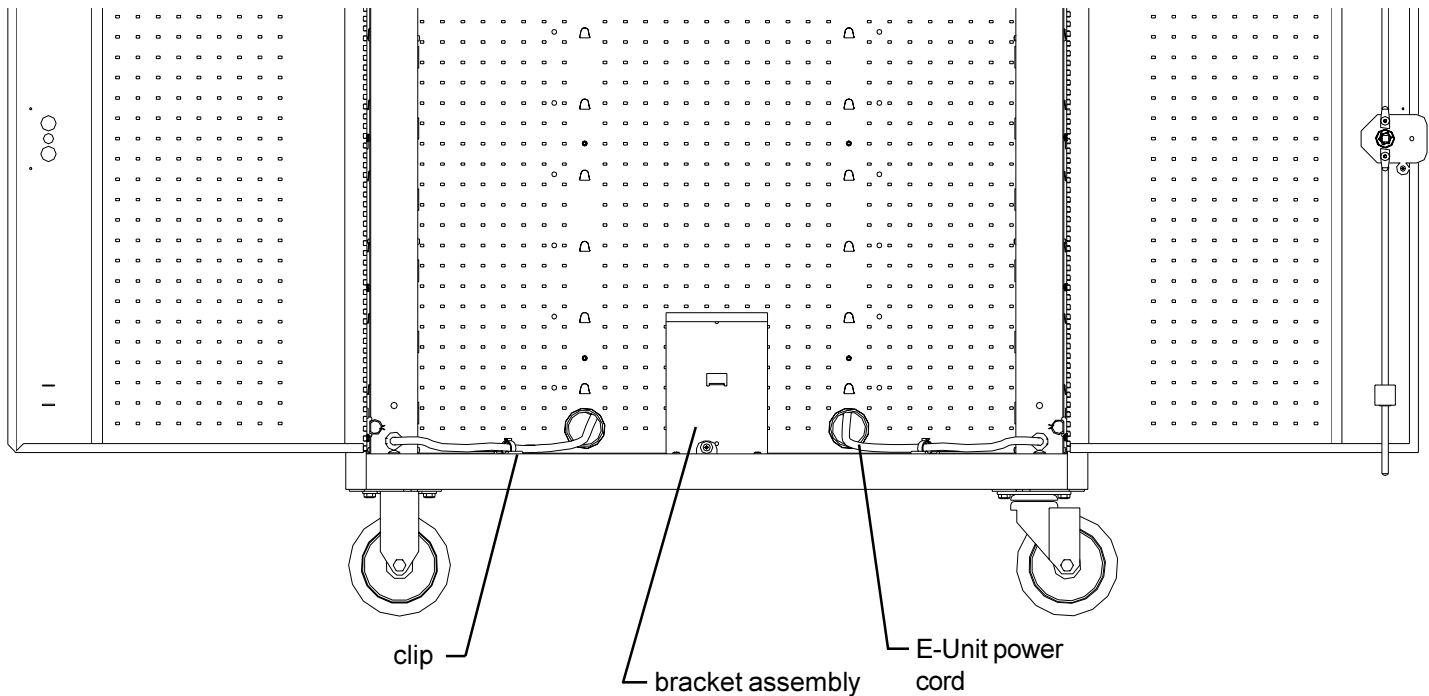

Front View

Unwind any length of power cord remaining on cord wrap brackets at rear exterior of cart. Unclip the power cords from the clips at the rear of cart. Loosen the screw holding the E-Unit bracket assembly and remove all 4 bracket assemblies (see DETAILS 'D' and 'E').

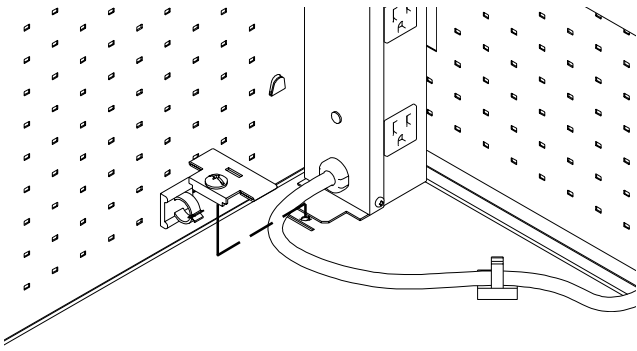

DETAIL 'D'

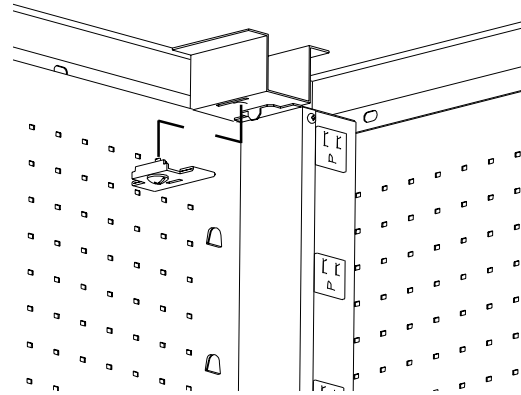

DETAIL 'E'

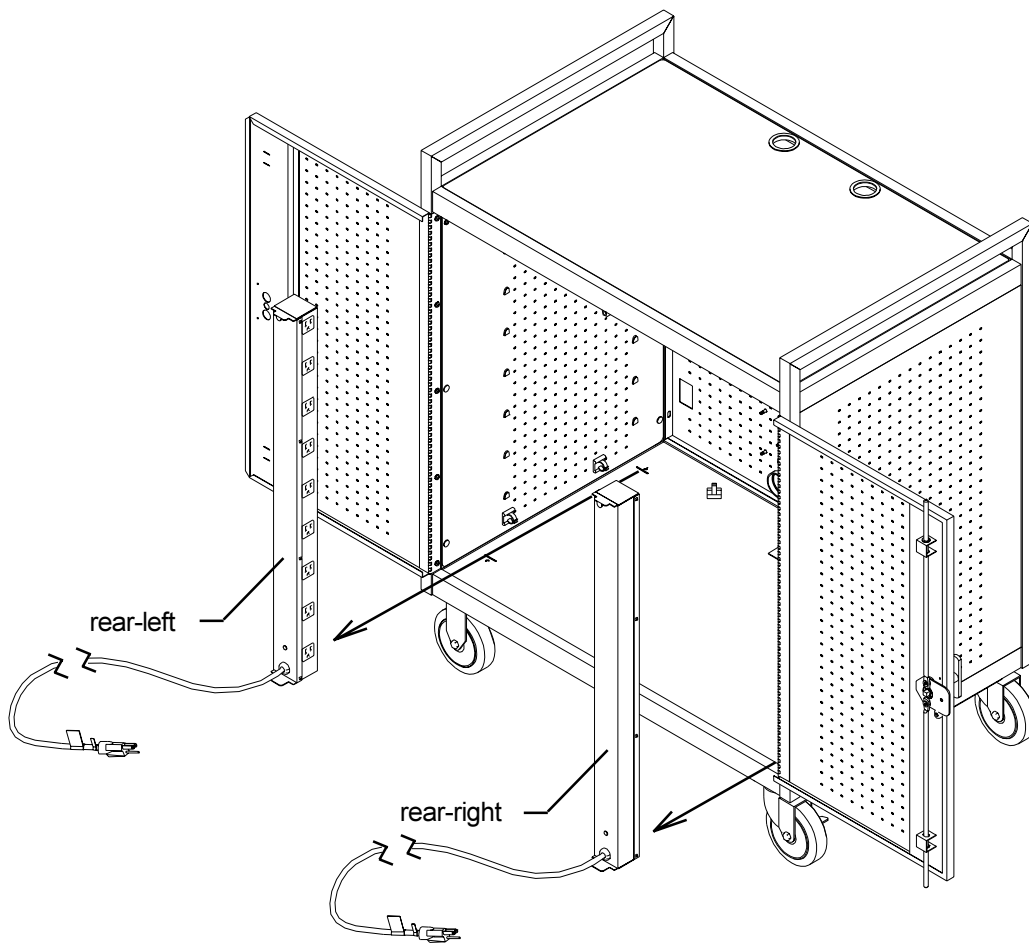

Step 3

Remove **rear-left** E-Unit by gripping the top and tilt it side ways until it clears the underside of the cart interior shelf bracket and set it aside.

Remove **rear-right** E-Unit by gripping the top and tilt it side ways until it clears the underside of the cart interior shelf bracket and set it aside.

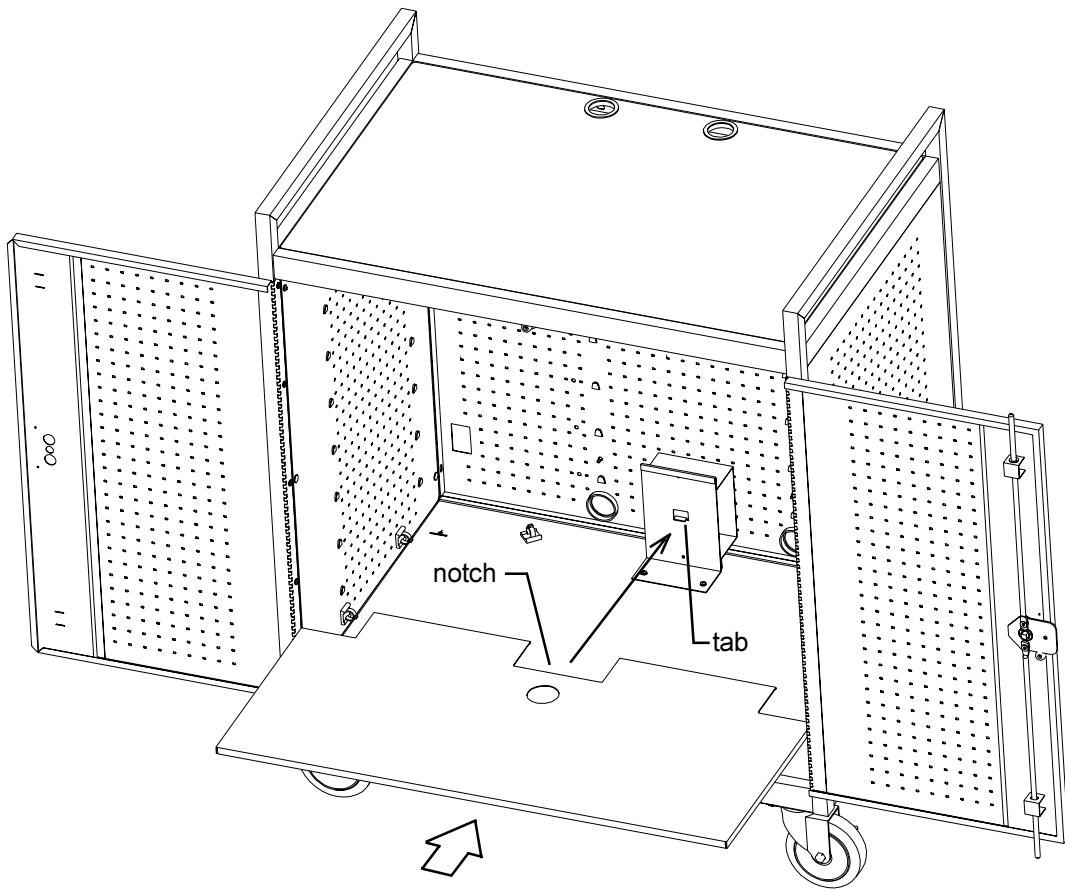

Step 4

Reinstall the 8 interior shelves as follows:

1. Carefully slide in the shelf with notch at the **bottom** position (the notch will rest on the bracket tab).
(Make sure that the shelf flanges are ALL seated into the mounting tabs.)
2. Slide in all remaining shelves into position as the bottom shelf.

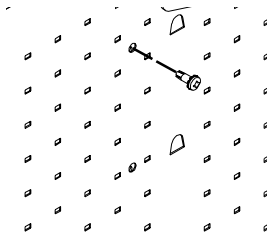
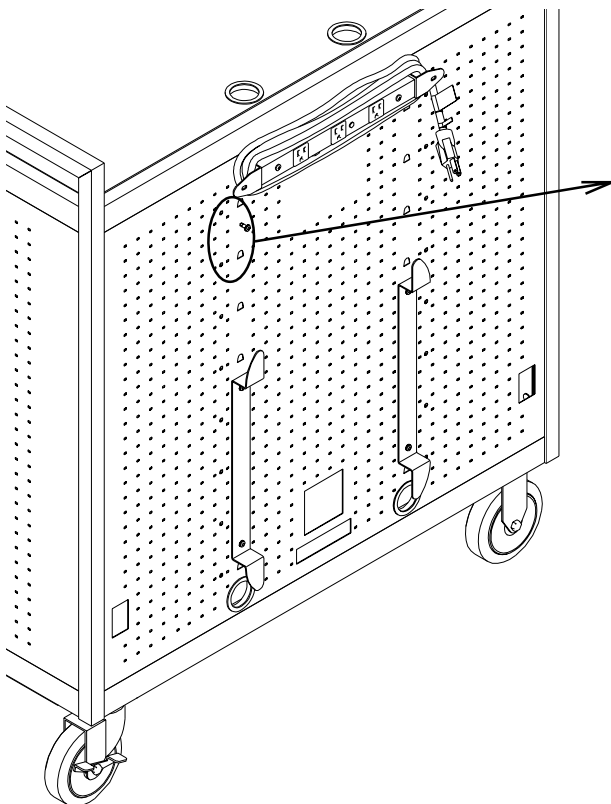

DETAIL 'F'

Step 5

Reinstall 16 screws to rear panel that will secure the 8 interior shelves (see DETAIL 'F'). **DO NOT OVER TIGHTEN SCREWS.**

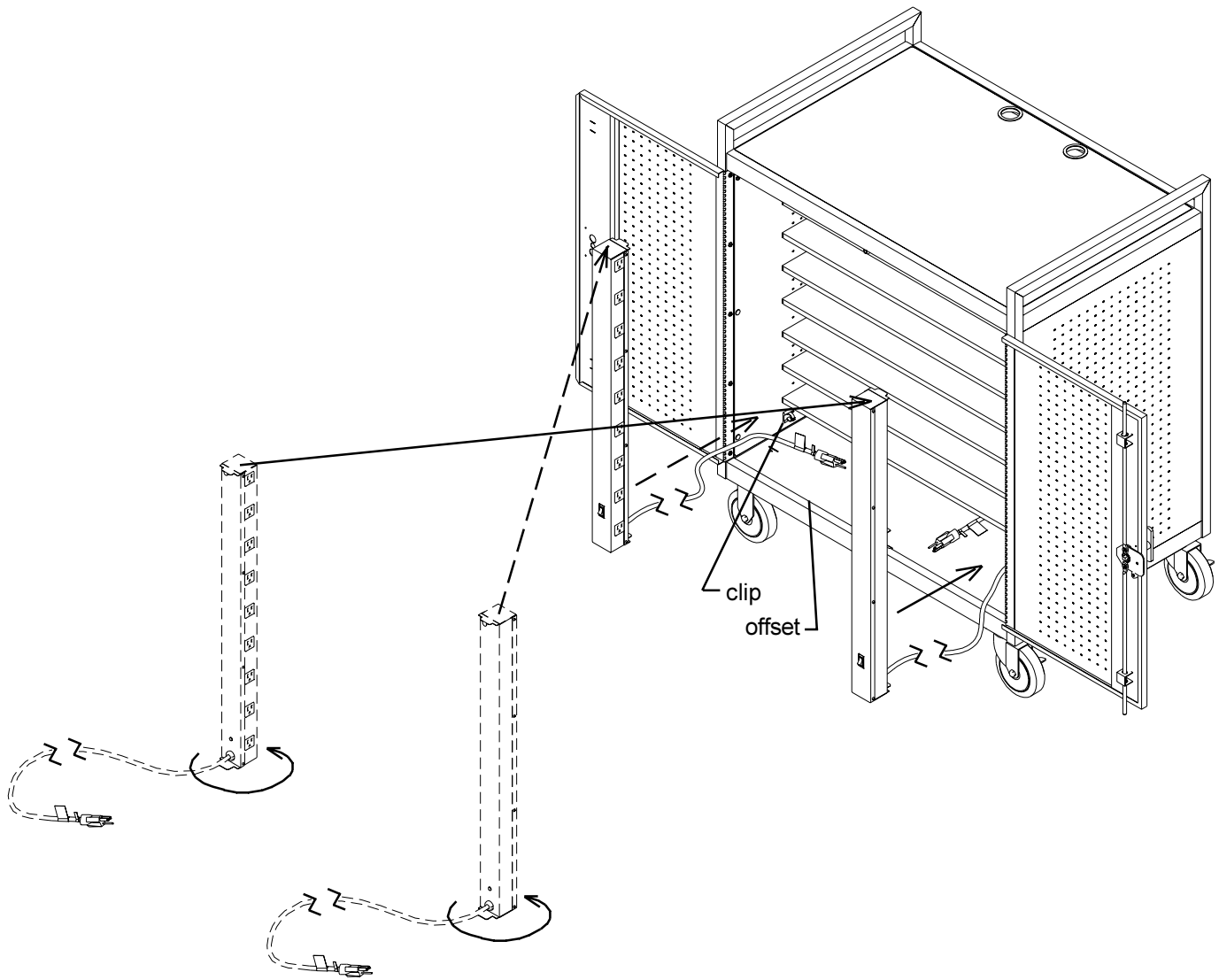

Step 6

Reinstall the E-Units (set aside from being removed from the rear) as follows:

1. Rotate the E-Unit 180 degrees (from original position).
2. Cross over to opposite corner of cart.
3. Tilt in and set against offset of bottom panel (of cart).
4. Grip the top and tilt to the upright position.

When repositioned correctly, the E-Unit outlets face the interior and power switch should face the front. Reinstall the E-Unit bracket assemblies (make sure that the top flange of the E-unit is aligned with the slot in the bracket assembly) and tighten screws securely. Feed the power cords (plug end) all the way through the bottom rear round cutouts (next to bracket assembly). Press each E-Unit power cord into the two wire clips located on the side panel, bottom. Wind power cords around the cord wrap bracket located above each round cutout for storage.

Installation is now complete and ready for use.

NOTE:
UNPLUG CART POWER CORDS FROM POWER
SOURCE BEFORE STARTING

E-UNIT REPLACEMENT:
'REAR LOCATION'

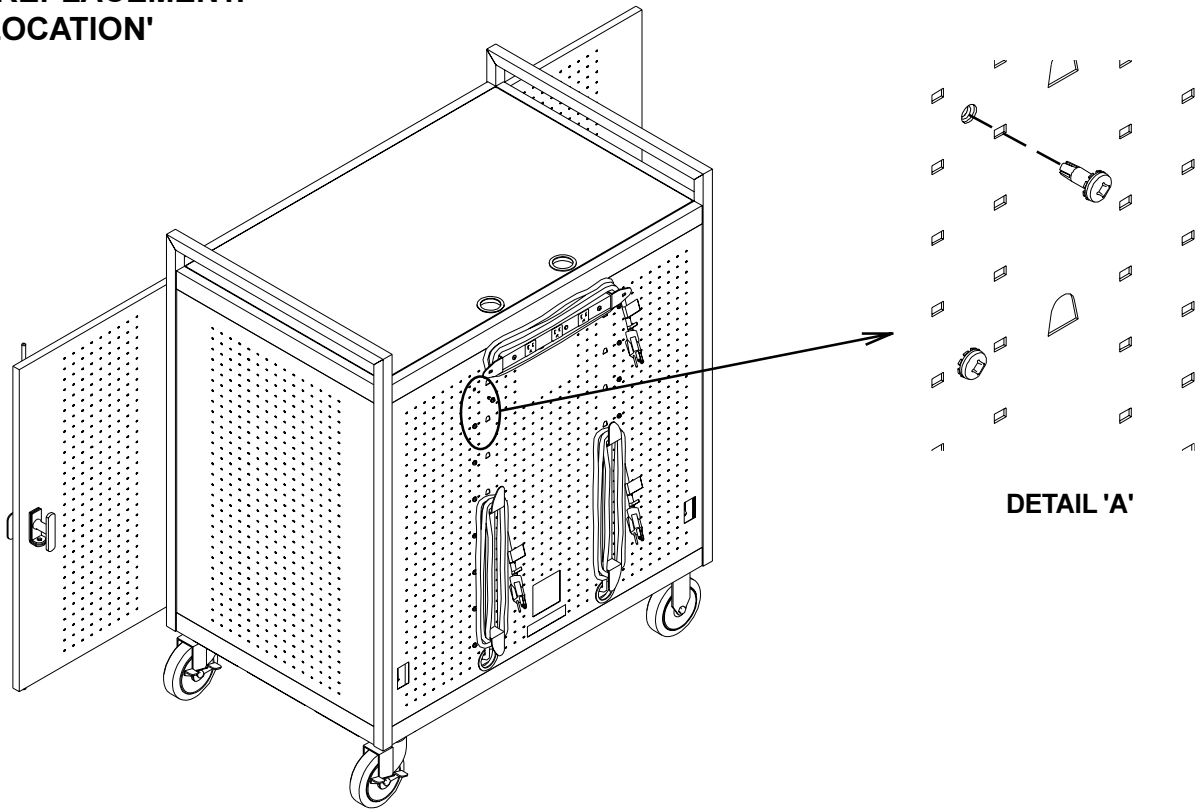

Step 1

Remove 16 screws (2 per shelf) from rear panel that secure the 8 interior shelves (see DETAIL 'A').

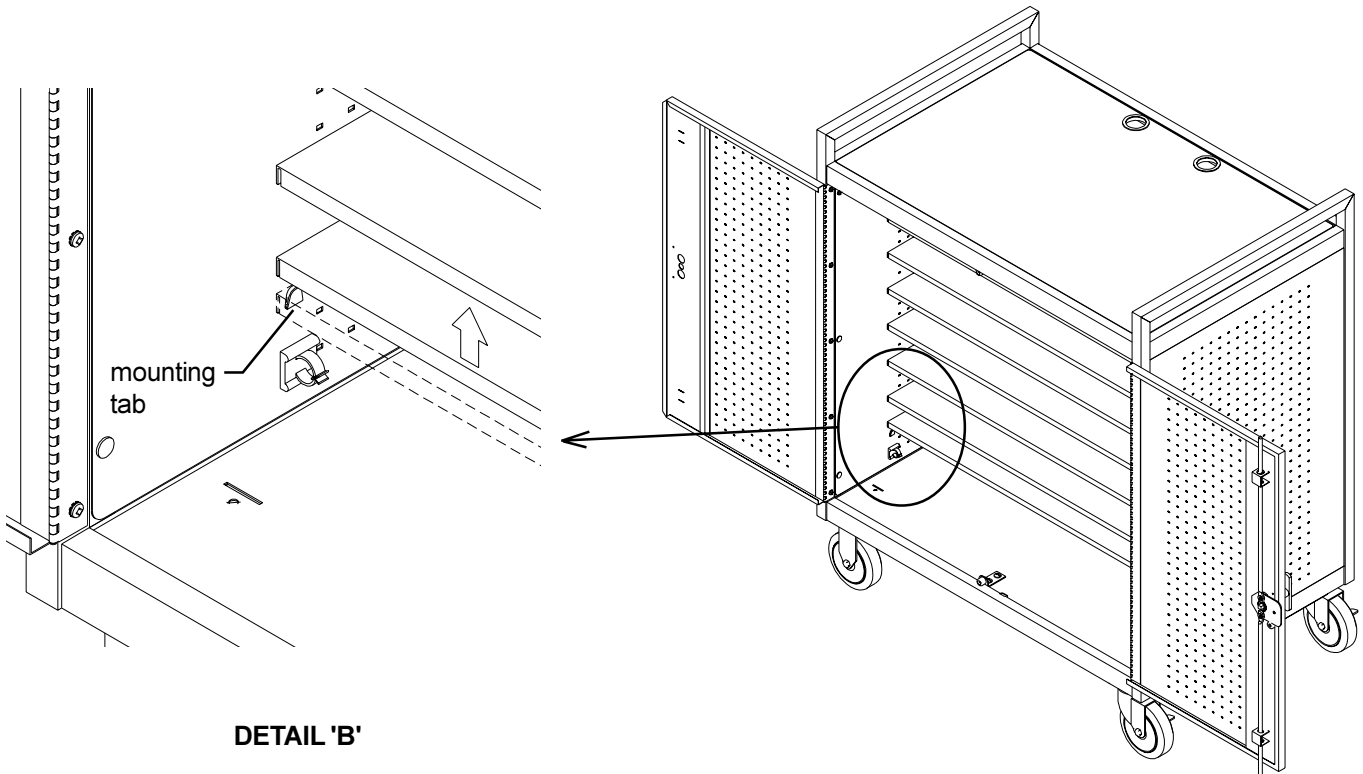

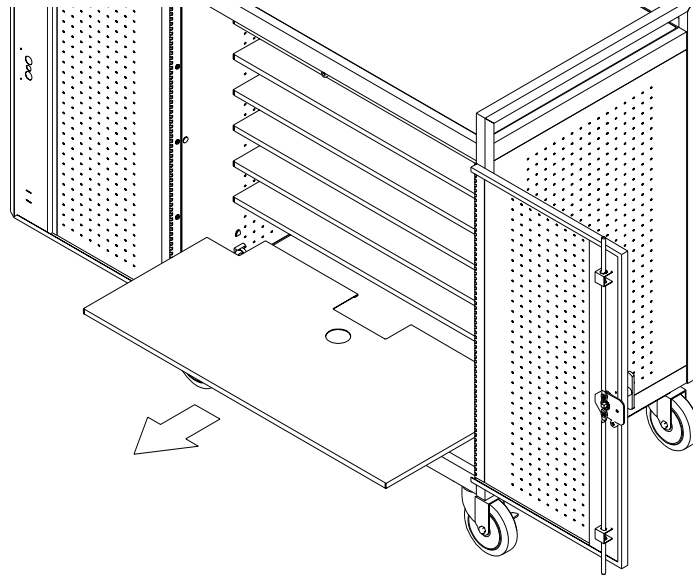

Step 2

With both doors open, remove each interior shelf by carefully pushing upward (to release shelf from mounting tabs) shown in Detail 'B', then carefully sliding out. Set each shelf aside.

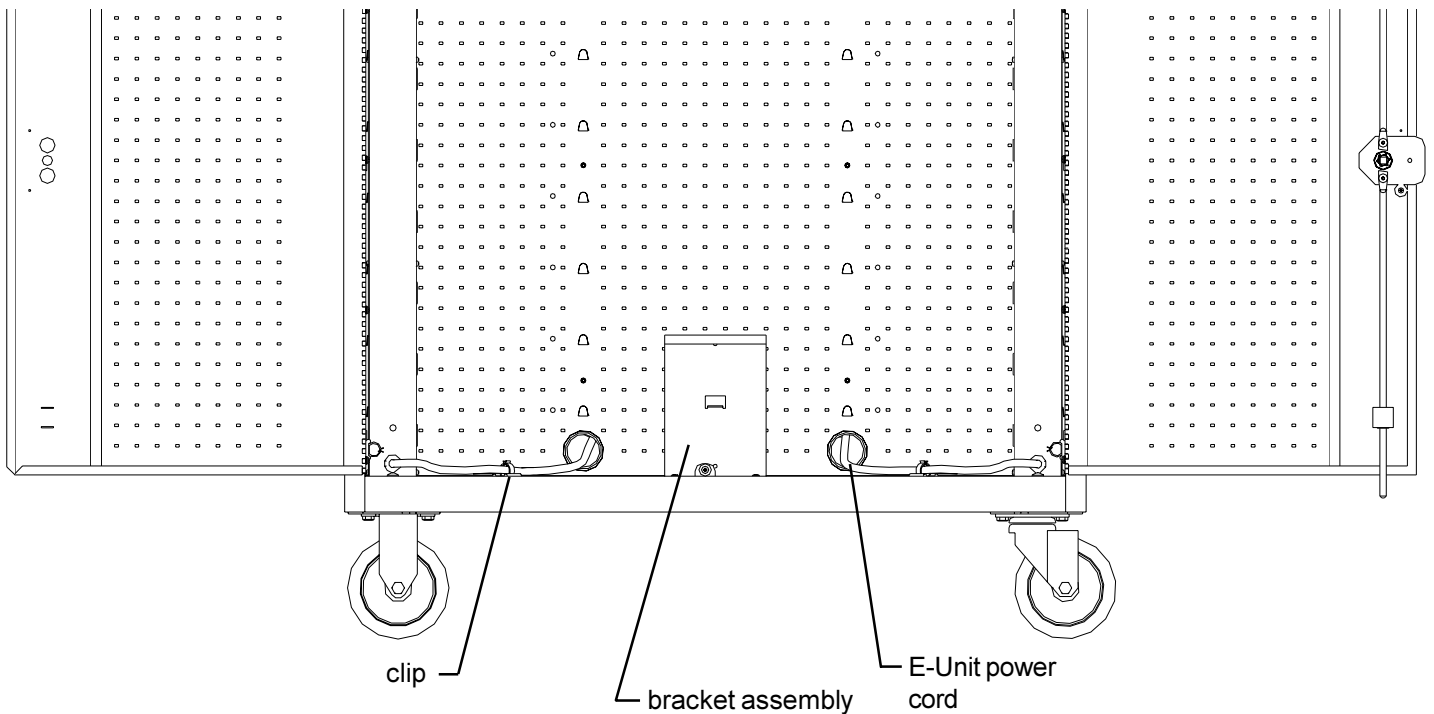

Front View

Unwind any length of power cord remaining on cord wrap bracket(s) at rear exterior of cart. Unclip the power cord(s) from the clip(s) at the rear of cart. Loosen the screw holding the E-Unit bracket assembly and remove each bracket assembly (see DETAILS 'C' and 'D').

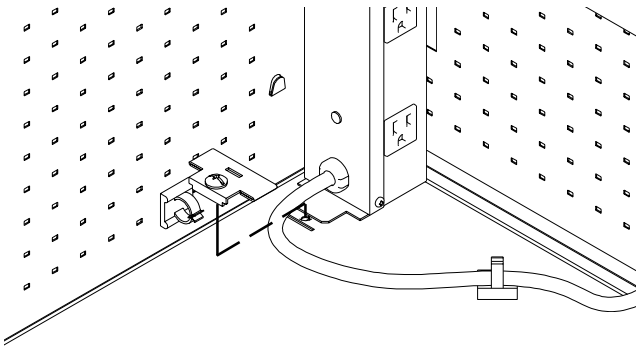

DETAIL 'C'

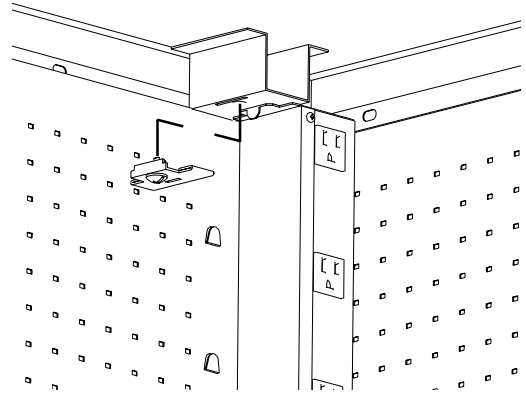

DETAIL 'D'

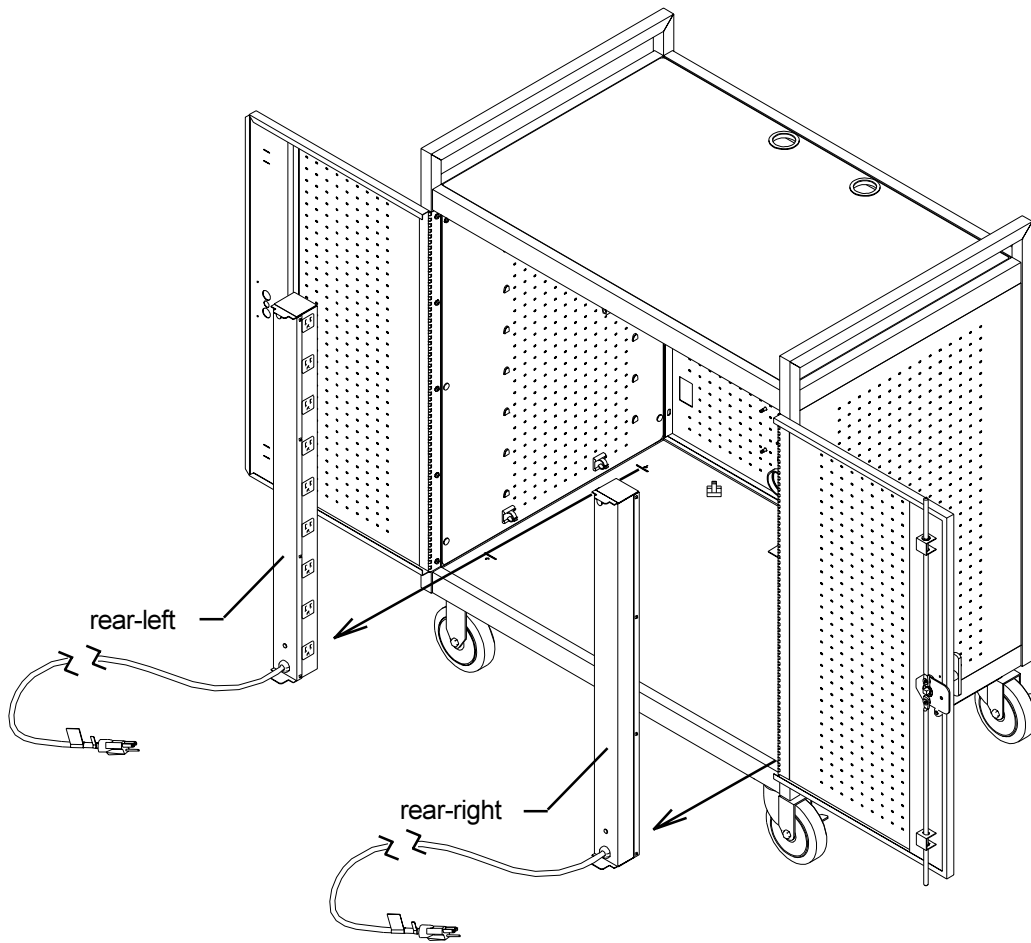

Step 3

Remove E-Unit(s) by gripping the top and tilt it side ways until it clears the underside of the cart interior shelf bracket and set it aside.

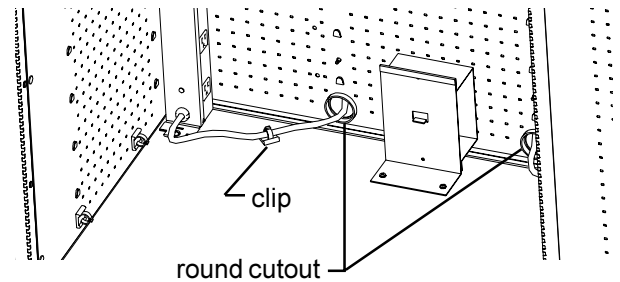
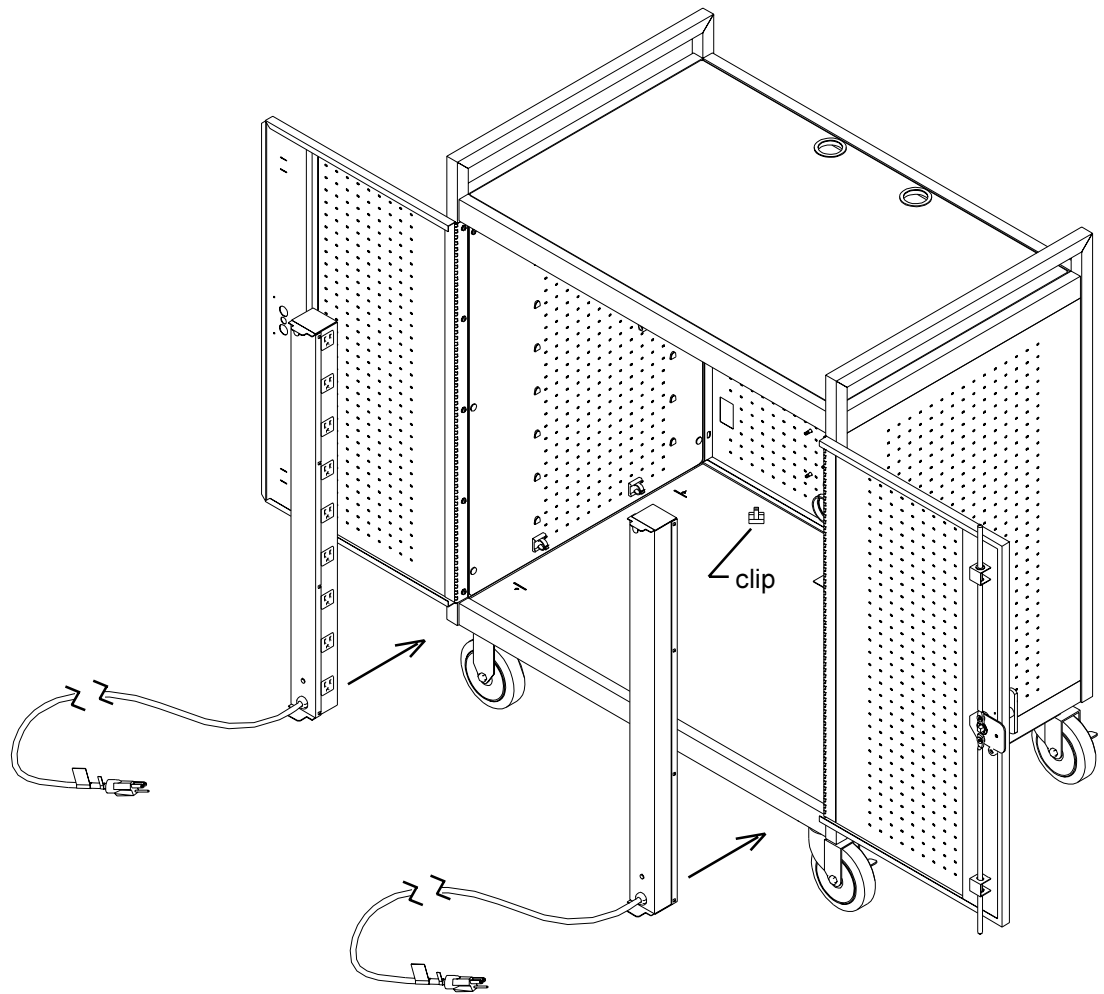

Figure 1

Step 4

Carefully install replacement E-Unit(s) into position by placing bottom in first and tilting in sideways to the top. When repositioned correctly, the E-Unit(s) outlets face the interior and power switch should be visible from rear panel cutout.

Reinstall the E-Unit bracket assemblies (make sure that the top flange of the E-unit is aligned with the slot in the bracket assembly) and tighten screws securely.

Feed the power cords (plug end) all the way through the bottom rear round cutout (next to the bracket assembly) shown in Figure 1.

Press each E-Unit power cord into the single wire clip located at the rear/bottom of the cart only.

Wind power cords around the cord wrap bracket located above each round cutout for storage.

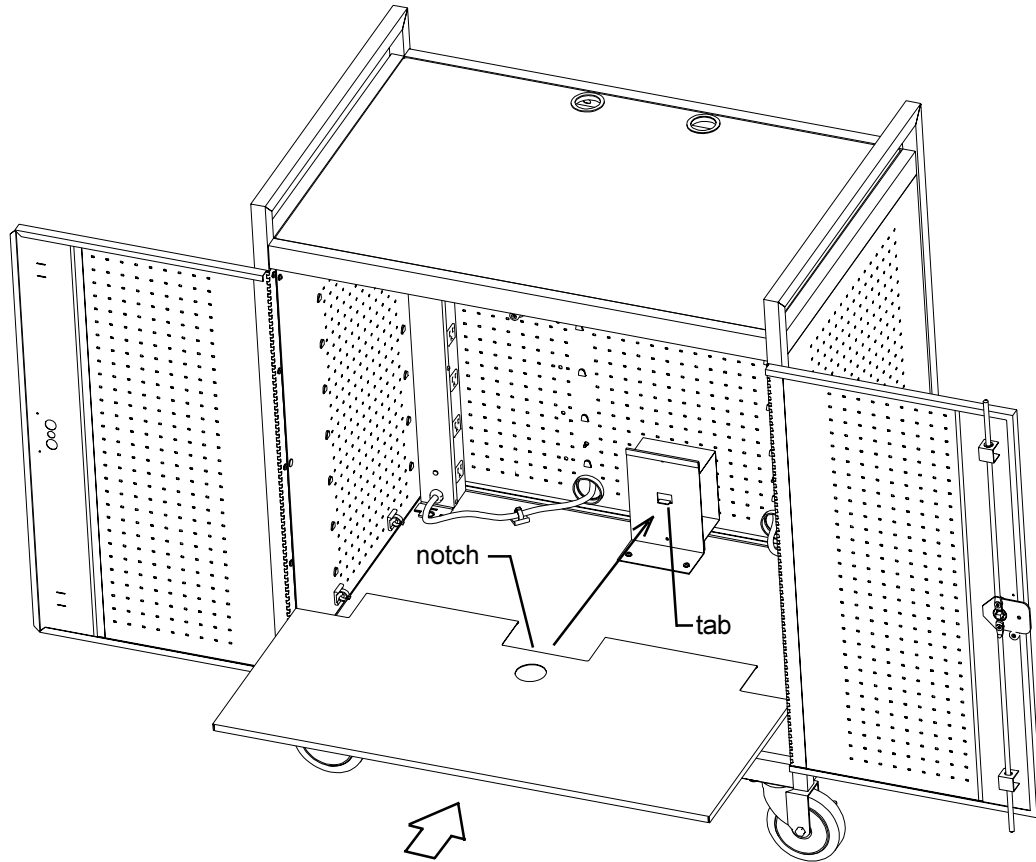

Step 5

Reinstall the 8 interior shelves as follows:

1. Carefully slide in the shelf with notch at the **bottom** position (the notch will rest on the bracket tab).
(Make sure that the shelf flanges are ALL seated into the mounting tabs.)
2. Slide in all remaining shelves into position as the bottom shelf.

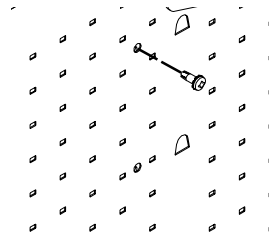
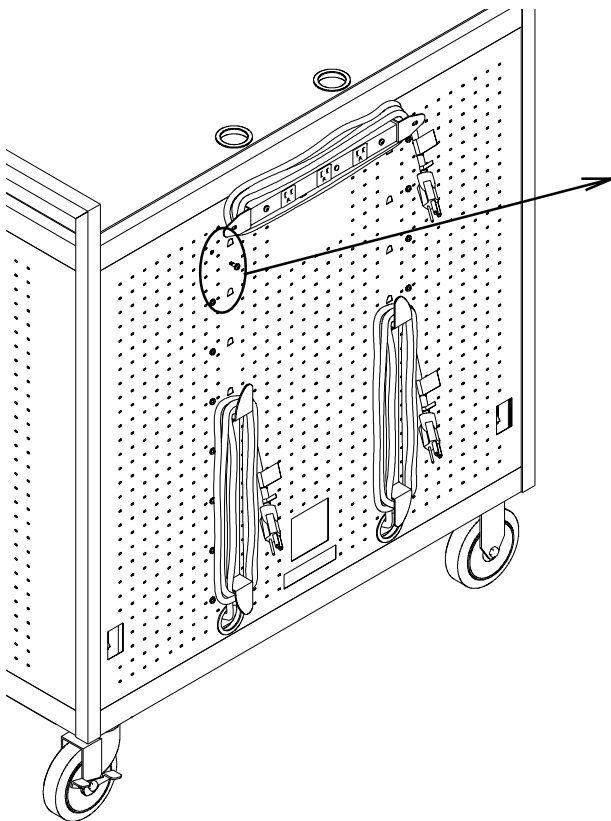

DETAIL 'E'

Step 6

Reinstall 16 screws to rear panel that will secure the 8 interior shelves (see DETAIL 'E'). **DO NOT OVER TIGHTEN SCREWS.**

Installation is now complete and ready for use.

NOTE:
UNPLUG CART POWER CORD FROM POWER
SOURCE BEFORE STARTING

E-UNIT REPLACEMENT:
'FRONT LOCATION'

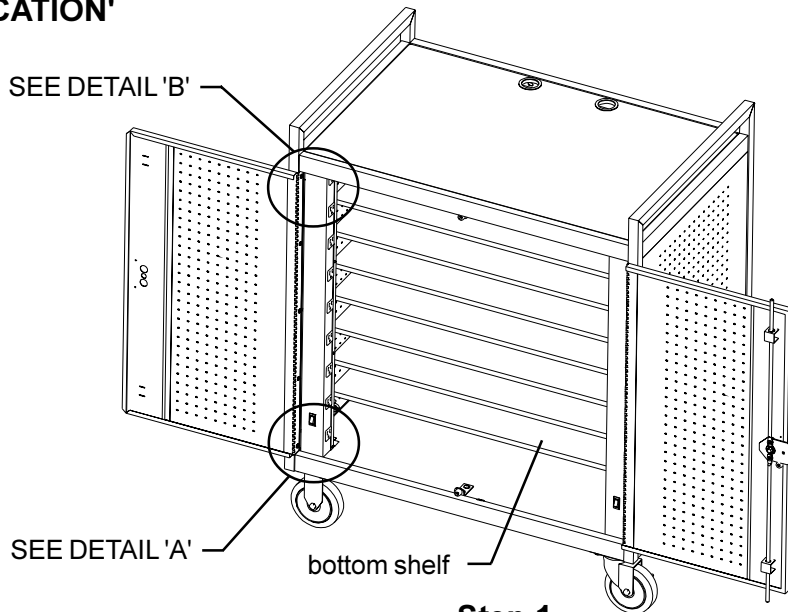

Step 1

Open both front doors of cart to access E-Unit(s). Unwind any length of E-Unit power cord remaining on the back panel cord wrap bracket(s). Unclip the power cord(s) from the side panel clips (see DETAIL 'A'). Loosen the screw holding the E-Unit bracket assembly and remove (2) bracket assemblies of the E-Unit(s) to be replaced (see DETAILS 'A' and 'B').

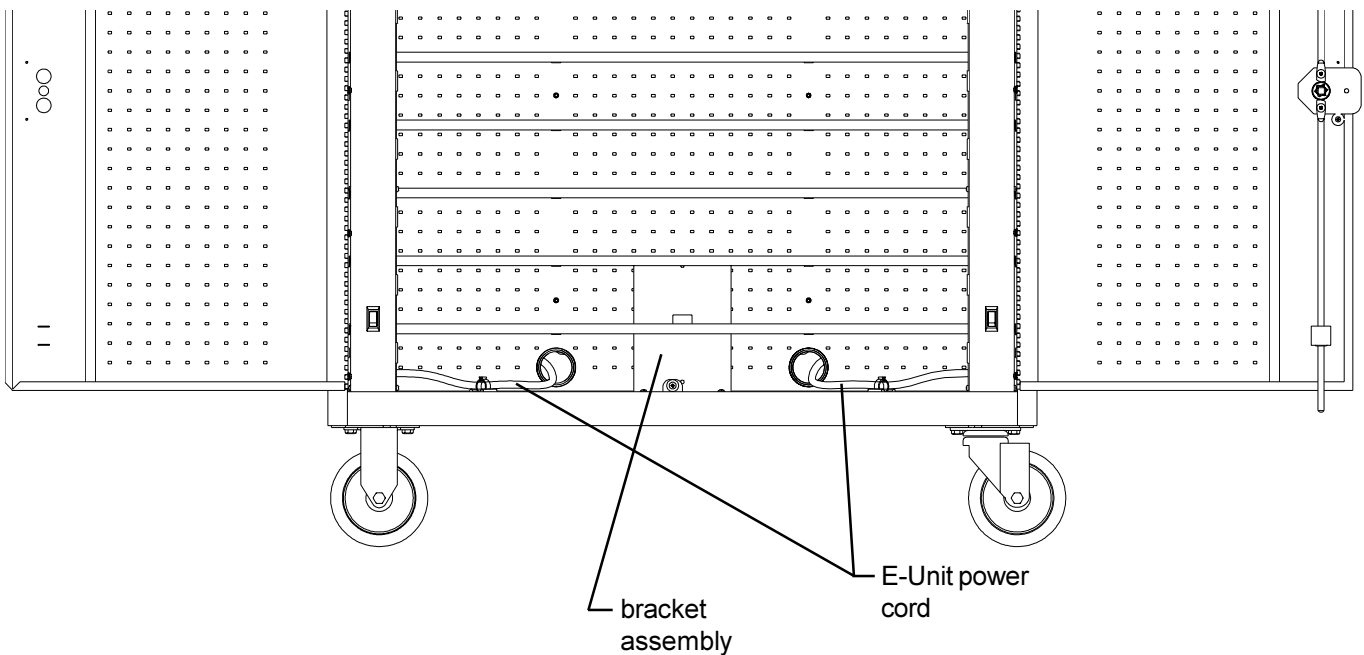

bracket assembly

E-Unit power cord

Front View

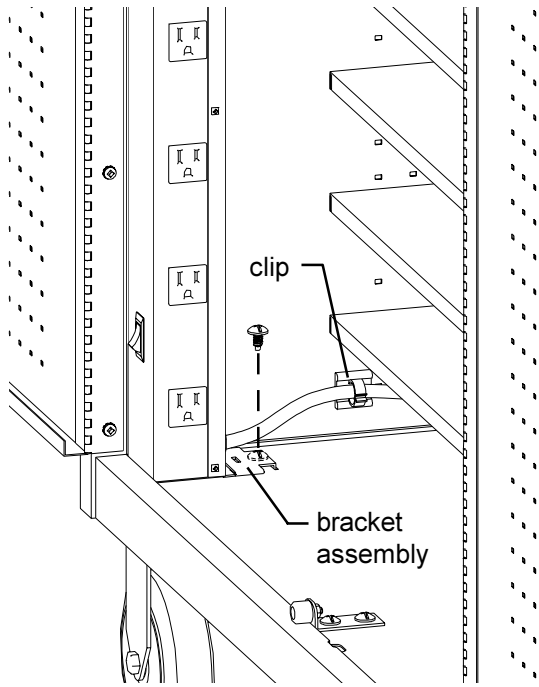

DETAIL 'A'

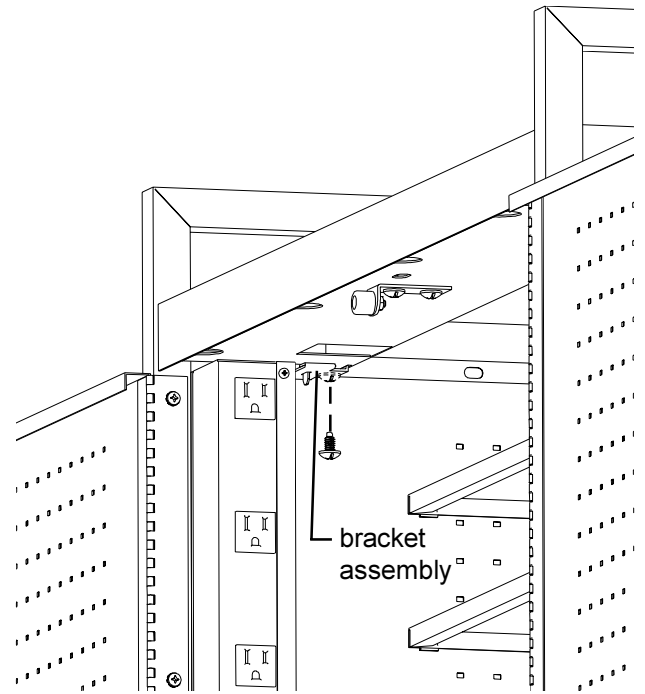

DETAIL 'B'

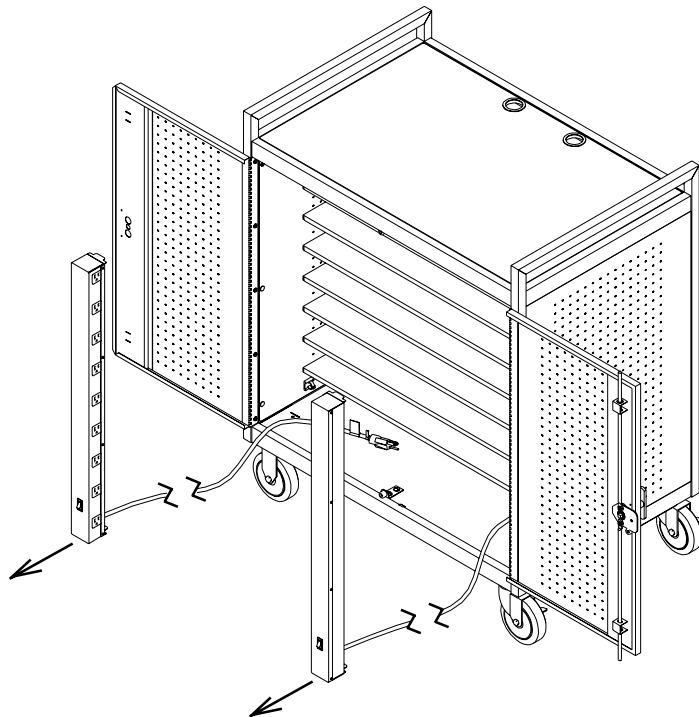

Step 2

Remove E-Unit(s) by gripping the top and tilt it side ways until it clears the underside of the cart interior shelf channel and set it aside.

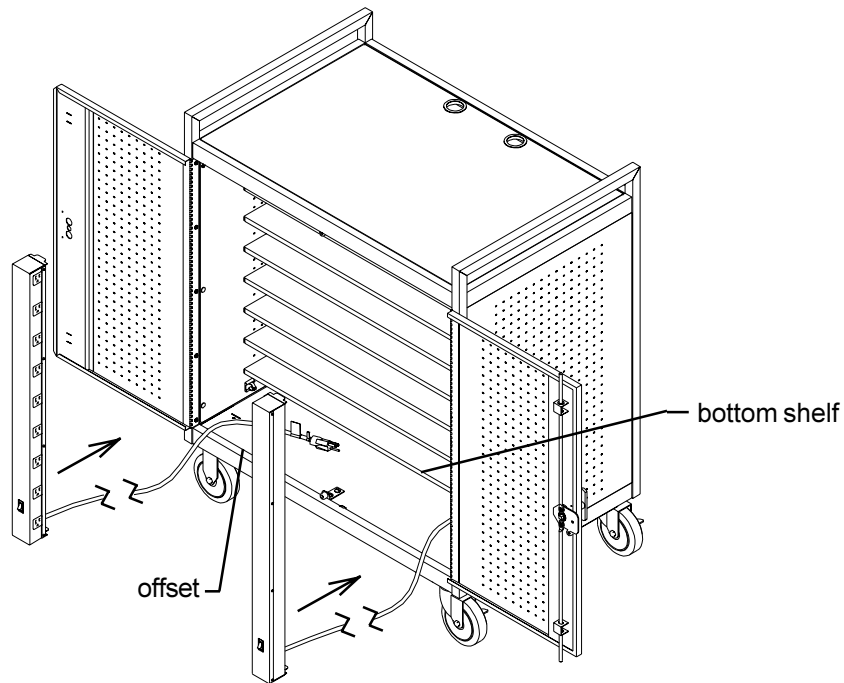

Step 3

Carefully install replacement E-Unit(s) into position by placing bottom in first, set against offset of bottom panel (of cart) and tilting it in sideways to the top.

When repositioned correctly, the E-Unit(s) outlets face the interior and power switch should face the front.

Reinstall the E-Unit bracket assemblies (make sure that the top flange of the E-unit is aligned with the slot in the bracket assembly) and tighten screws securely.

Feed the power cords (plug end) all the way through the bottom rear round cutouts (next to bracket assembly).

Press each E-Unit power cord into the two wire clips located on the side panel, bottom.

Wind power cords around the cord wrap bracket located above each round cutout for storage.

Do not use the rear, bottom wire clip.

Installation is now complete and ready for use.

NOTE:
UNPLUG CART POWER CORDS FROM
POWER SOURCE BEFORE STARTING

TIMER INSTALLATION:
'E-UNIT AT REAR LOCATION'

Please read and follow all instructions thoroughly. Bretford will not be held responsible for improper installation or misuse of the timer unit.

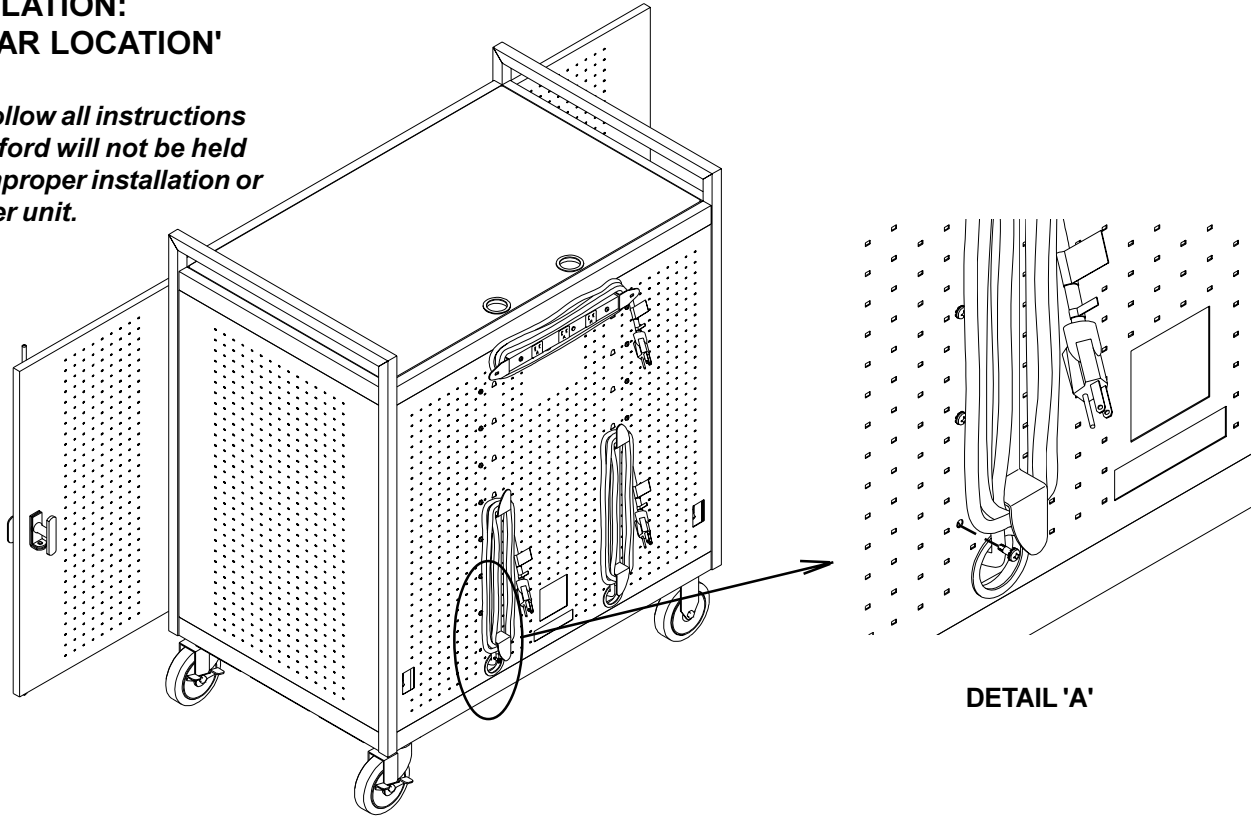

Step 1

Remove 6 screws (2 per shelf) from rear panel that secure the 3 **bottom** interior shelves (see DETAIL 'A').

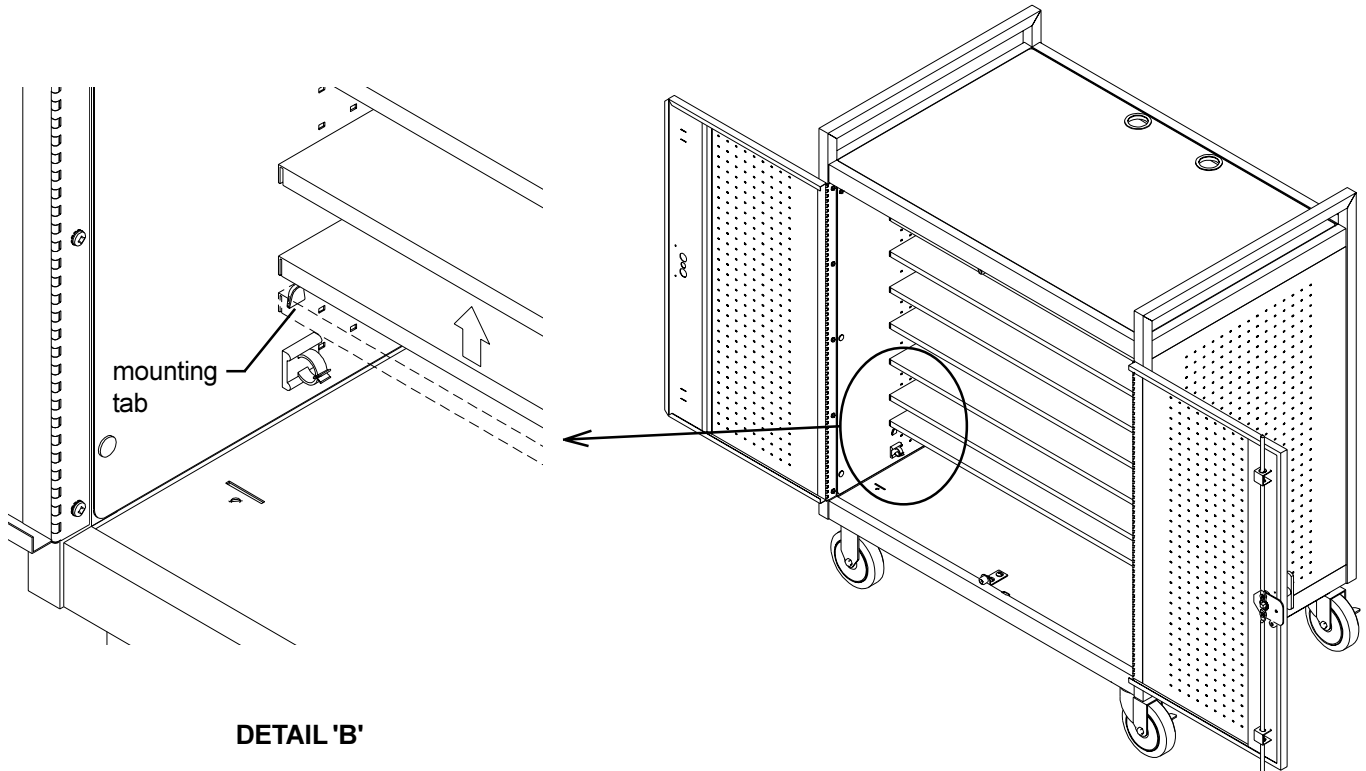

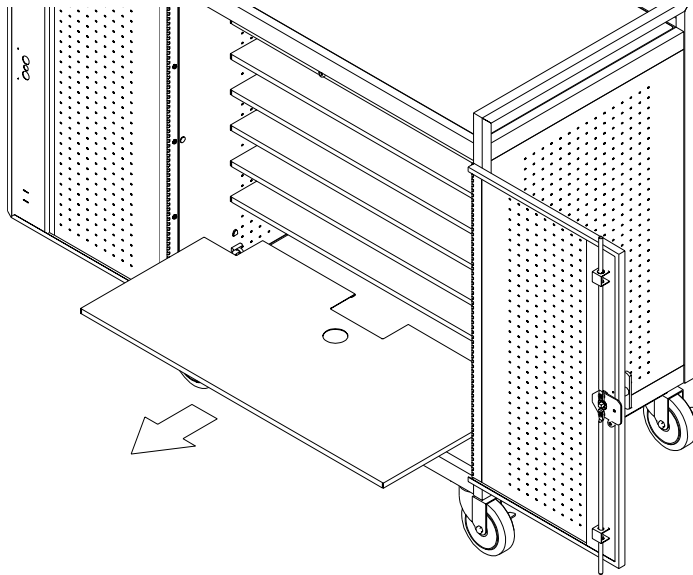

Step 2

With both doors open, remove the 3 bottom interior shelves by carefully pushing upward (to release shelf from mounting tabs) shown in Detail 'B', then carefully sliding out. Set each shelf aside.

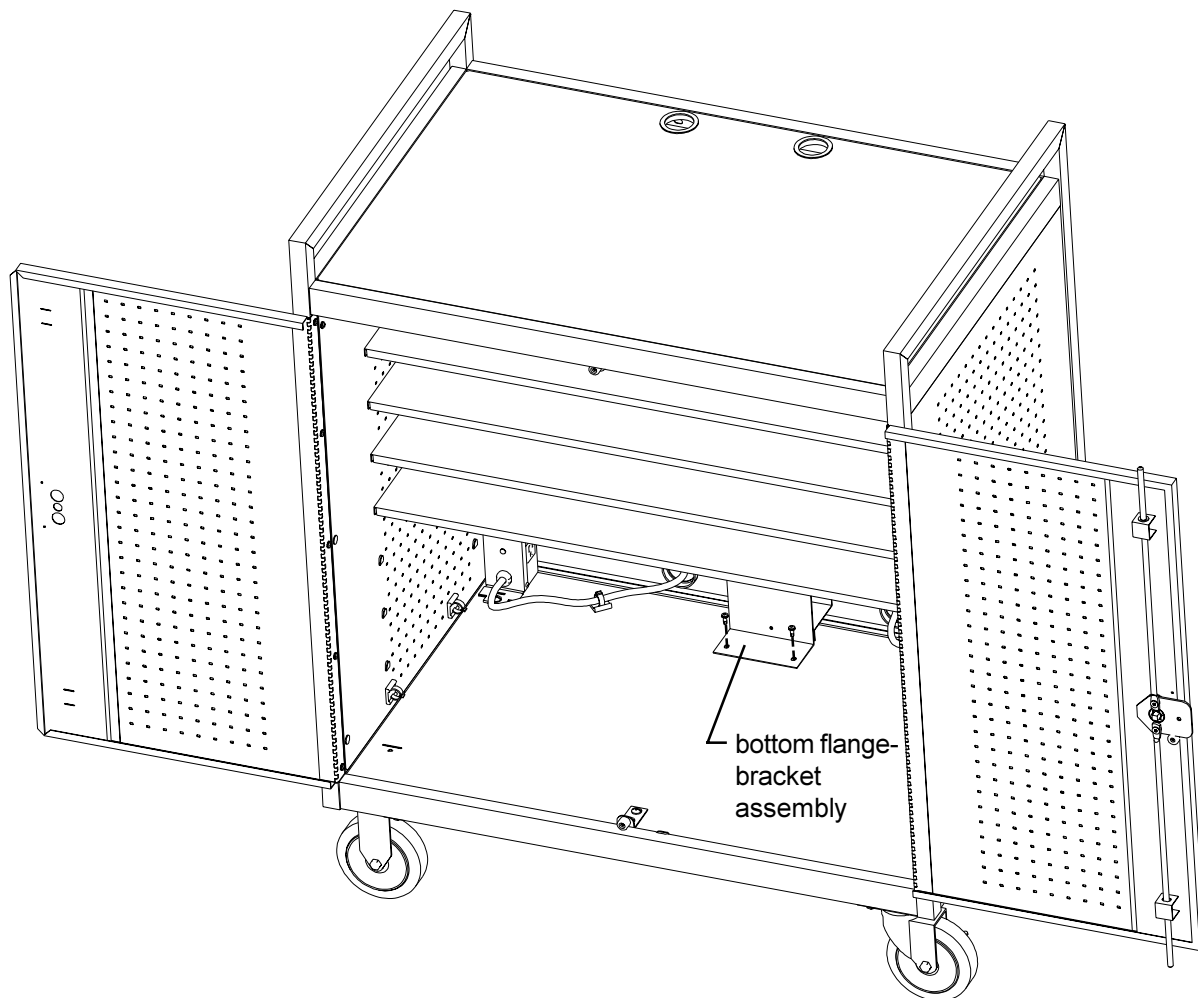

Step 3

Remove 2 screws from bottom flange (securing bracket to bottom of cart) and remove timer/bracket assembly.

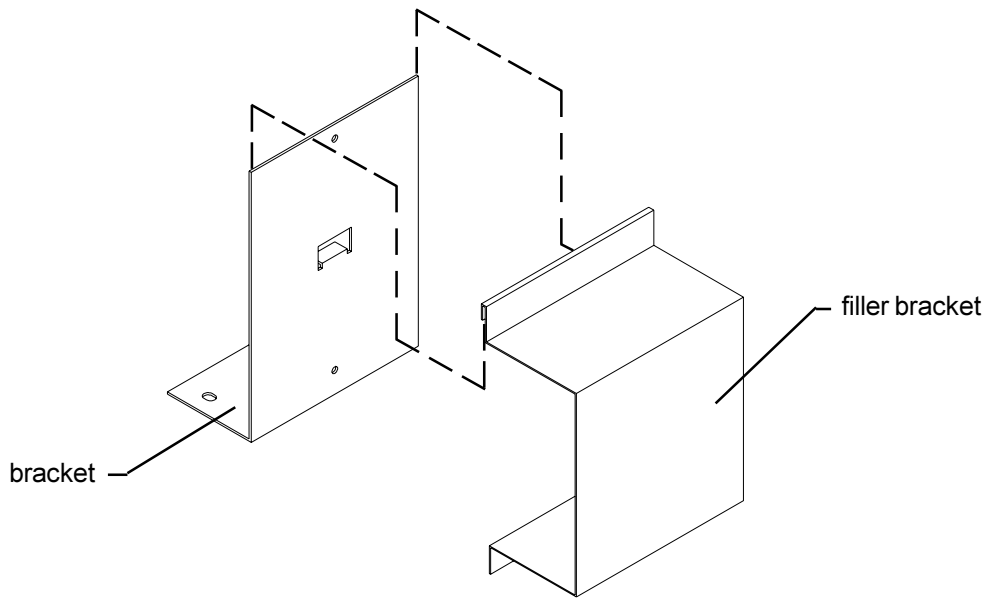

Step 4

Remove filler bracket from bracket by pulling upward. Discard filler bracket.

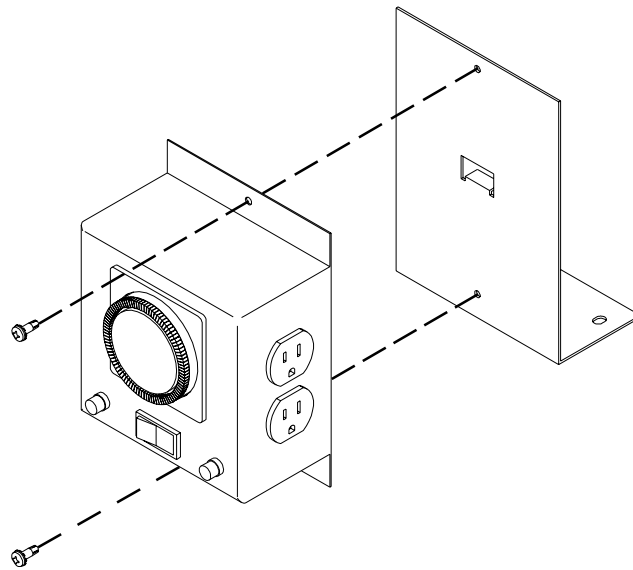

Step 5

Install timer with 2 screws. Adjust timer dial to current time. If necessary, adjust timer charging times to meet your schedule.

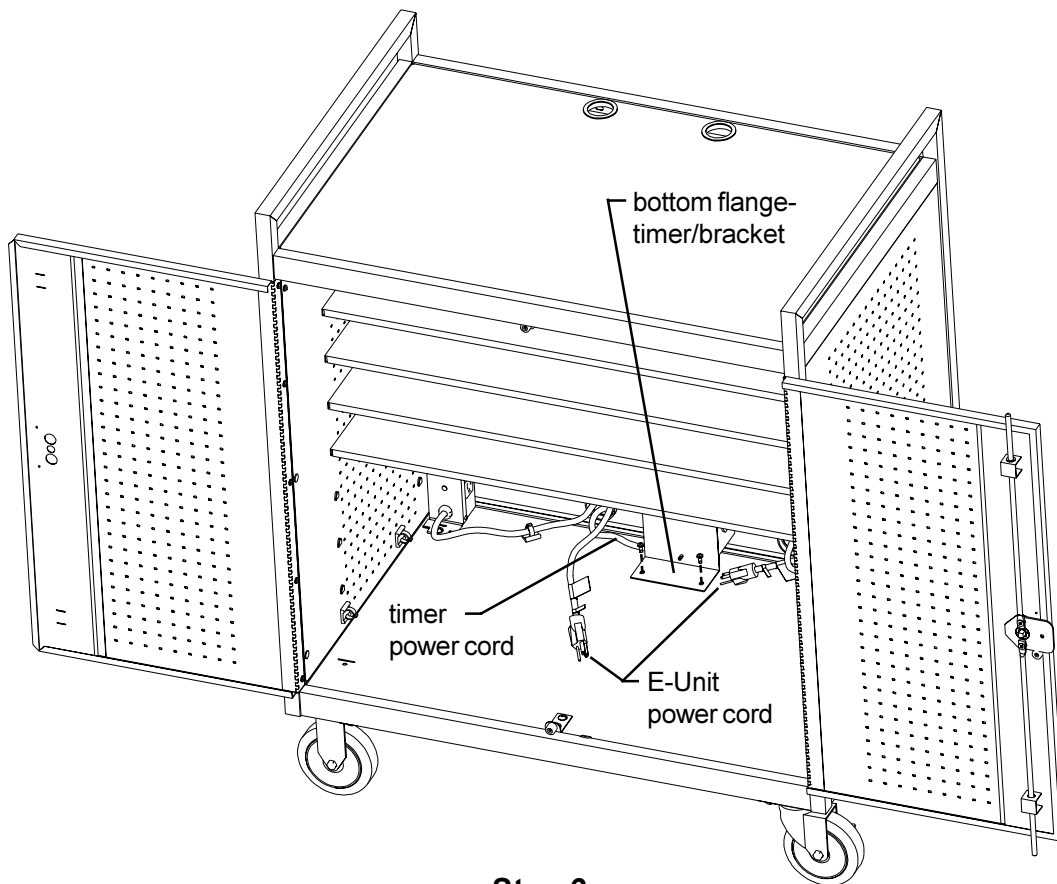

Step 6

Install timer/bracket assembly onto bottom, rear of cart with 2 screws (into bottom flange of timer bracket). Make sure timer face is aligned with rear panel cutouts. Tighten screws. Feed the power cord from the timer out the grommeted hole shown. Unwind enough E-Unit power cord from the cord brackets on the rear panel to feed back through each grommeted hole and into the timer. Plug one E-Unit power cord into the bottom outlet of the timer marked 'A' only and the other E-Unit power cord into the bottom outlet of the timer marked 'B' only. **DO NOT PLUG BOTH E-UNIT POWER CORDS INTO ONE SIDE MARKED 'A' OR 'B' OUTLETS. THIS WILL CAUSE AN OVER LOAD DURING THE CHARGING PROCESS.**

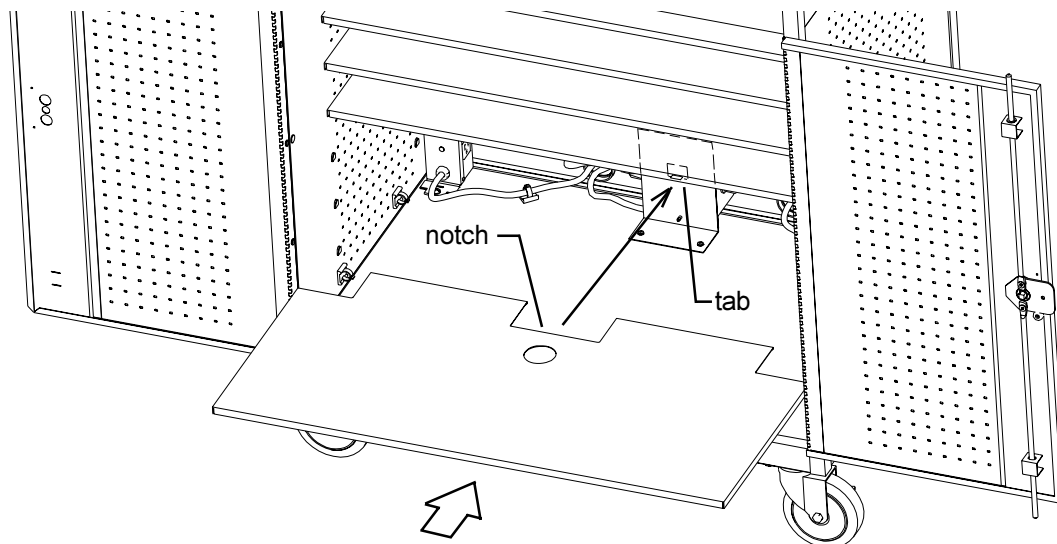

Step 7

Reinstall the 3 interior shelves as follows:

1. Carefully slide in the shelf with notch at the **bottom** position (the notch will rest on the bracket tab).
(Make sure that the shelf flanges are ALL seated into the mounting tabs.)
2. Slide in remaining 2 shelves into position as the bottom shelf.

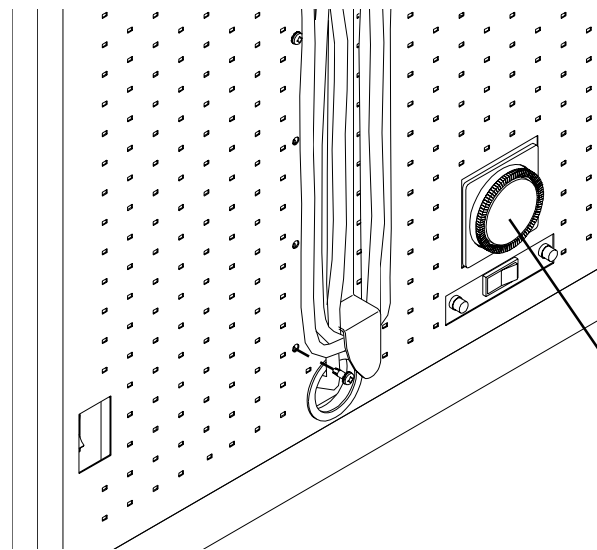
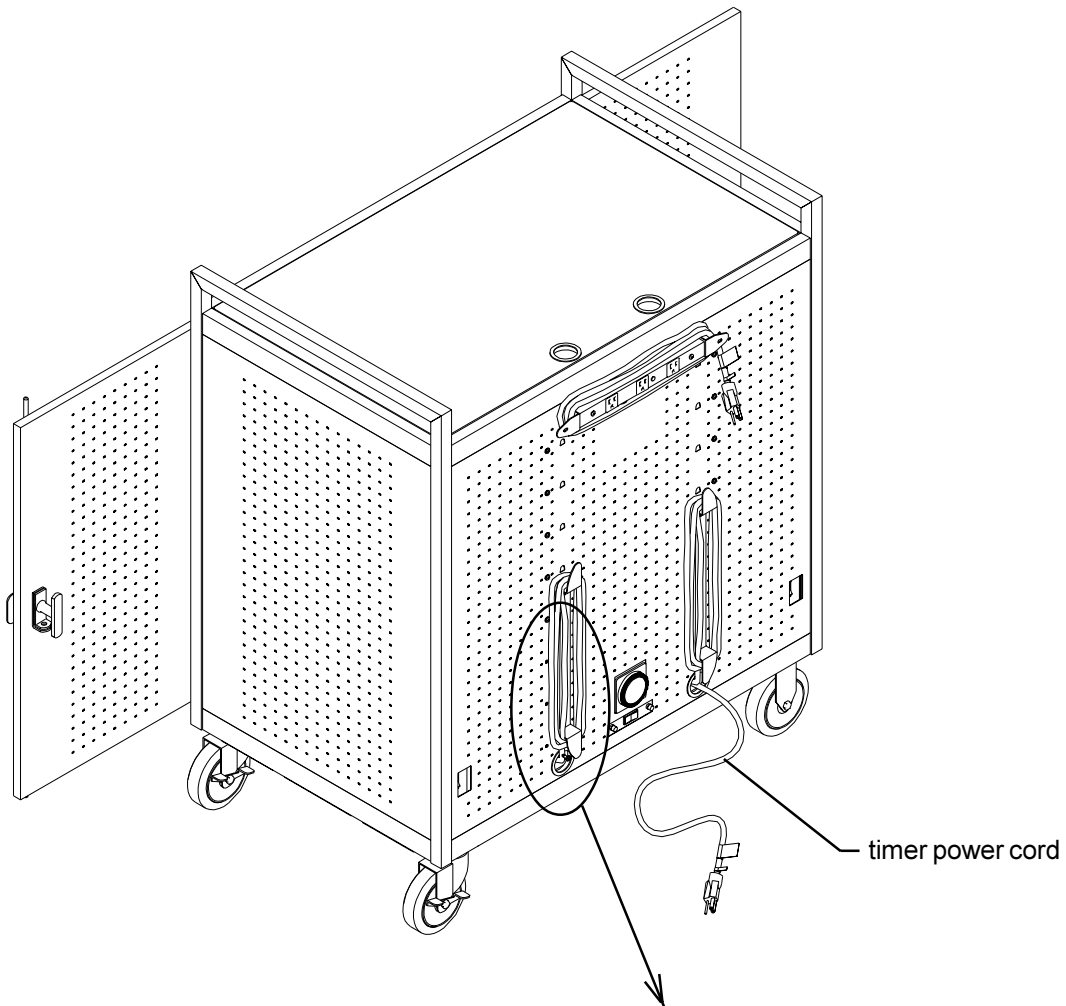

Adjust timer to current time when installation is complete and ready to be plugged back into power source. If necessary, adjust tabs for charging times.

DETAIL 'C'

Step 8

Reinstall 6 screws to rear panel that will secure the 3 interior shelves (see DETAIL 'C'). **DO NOT OVER TIGHTEN SCREWS.**

Installation is now complete and ready for use.

NOTE:

**UNPLUG CART POWER CORDS FROM
POWER SOURCE BEFORE STARTING**

**TIMER INSTALLATION:
'E-UNIT AT FRONT LOCATION'**

Please read and follow all instructions thoroughly. Bretford will not be held responsible for improper installation or misuse of the timer unit.

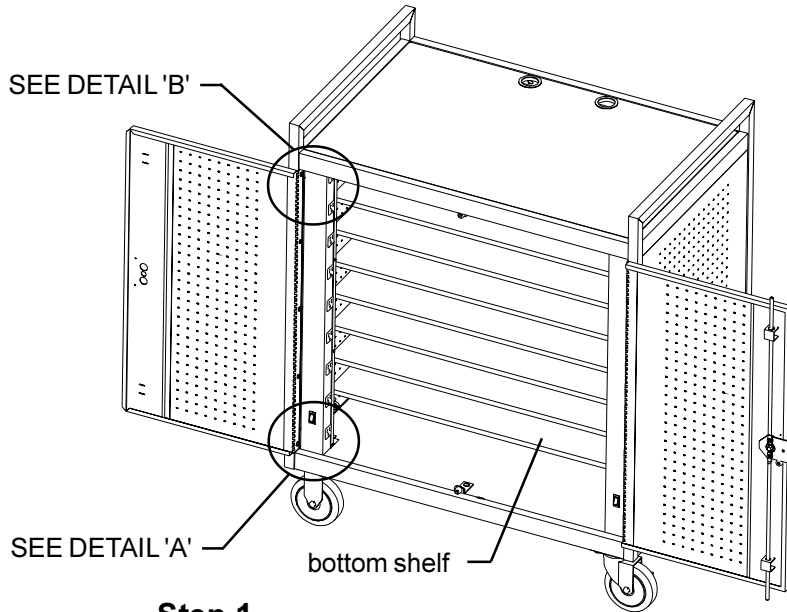

Step 1

Open both front doors of cart to access E-Units. Unwind any length of E-Unit power cord remaining on the back panel cord wrap brackets. Unclip the power cords from the side panel clips (see DETAIL 'A'). Loosen the screw holding the E-Unit bracket assembly and remove all 4 bracket assemblies (see DETAILS 'A' and 'B').

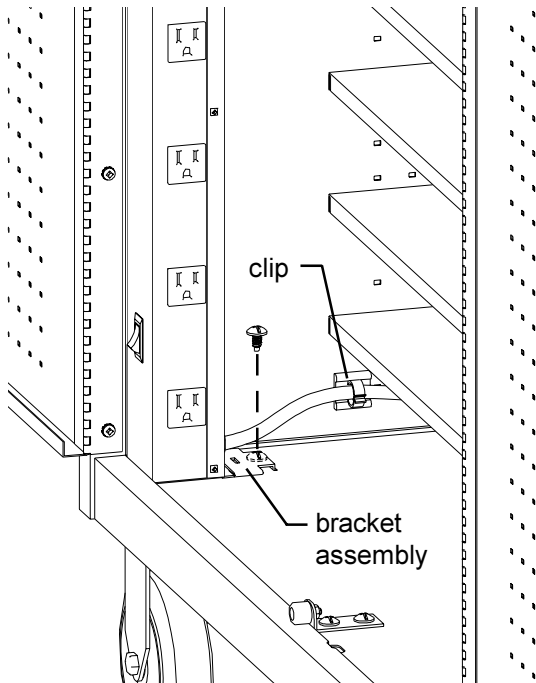

DETAIL 'A'

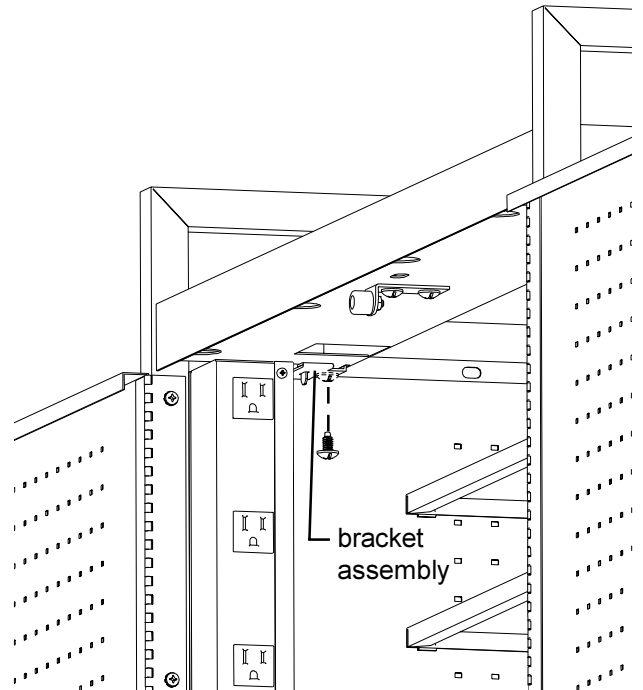

DETAIL 'B'

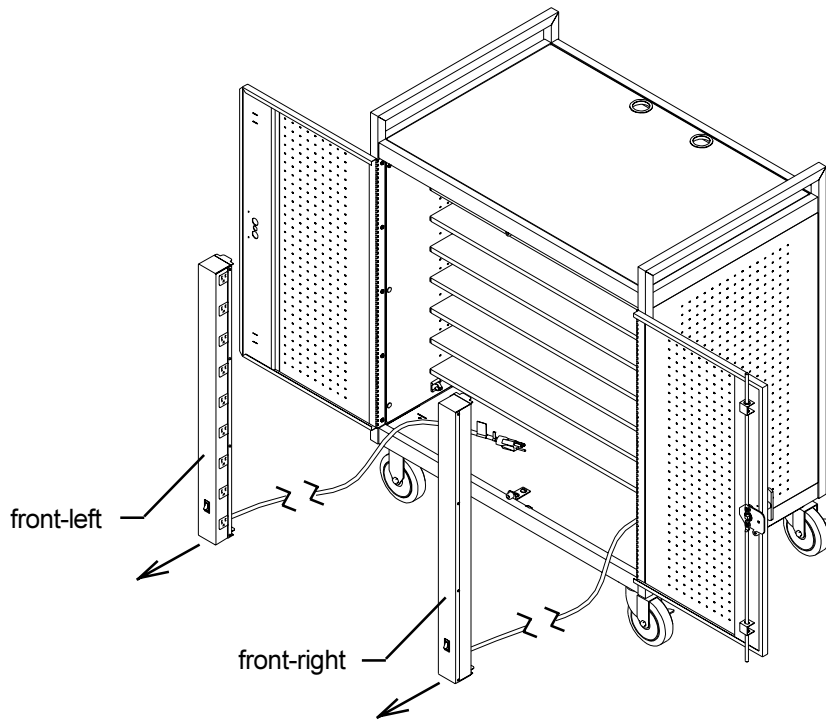

Step 2

Remove **front-left** E-Unit by gripping the top and tilt it side ways until it clears the underside of the cart interior shelf channel and set it aside.

Remove **front-right** E-Unit by gripping the top and tilt it side ways until it clears the underside of the cart interior shelf channel and set it aside.

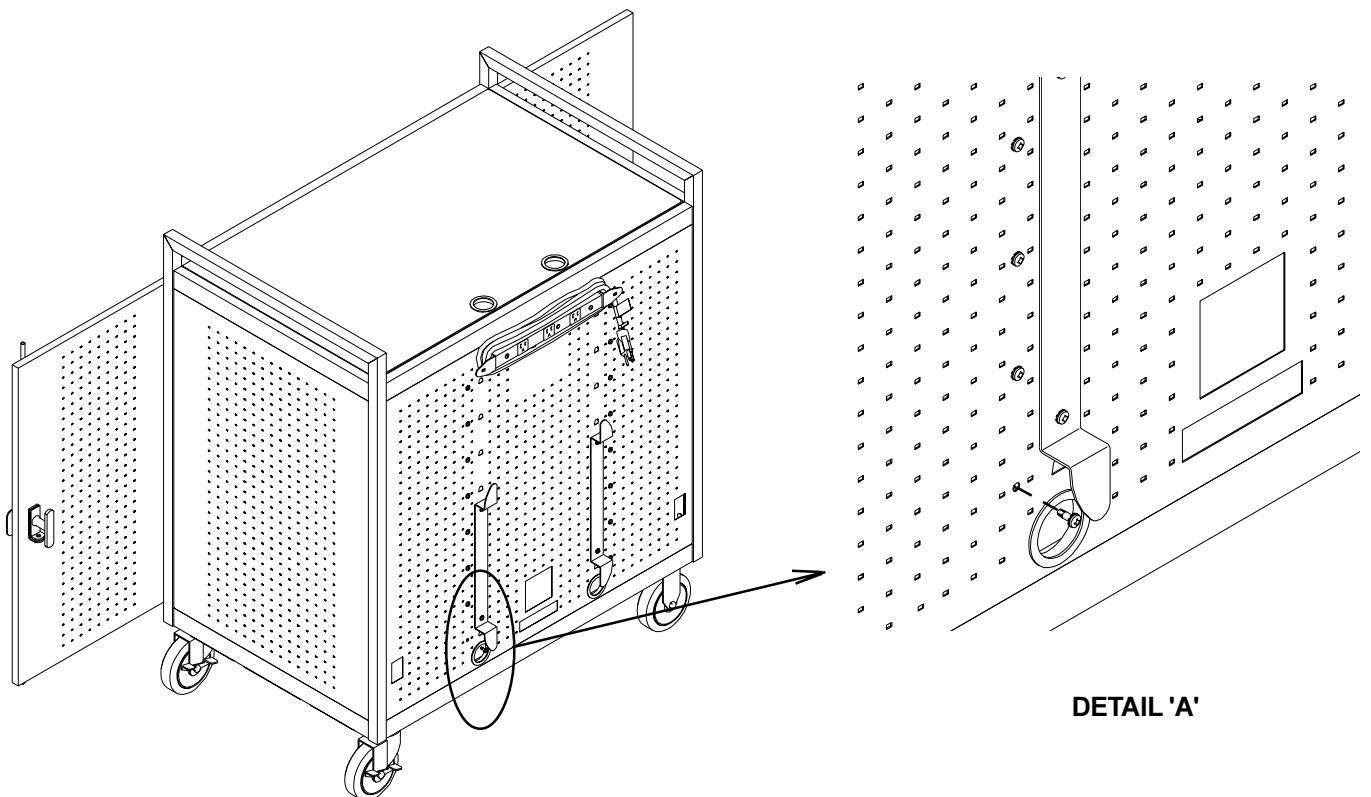

Step 3

Remove 6 screws (2 per shelf) from rear panel that secure the 3 **bottom** interior shelves (see DETAIL 'A').

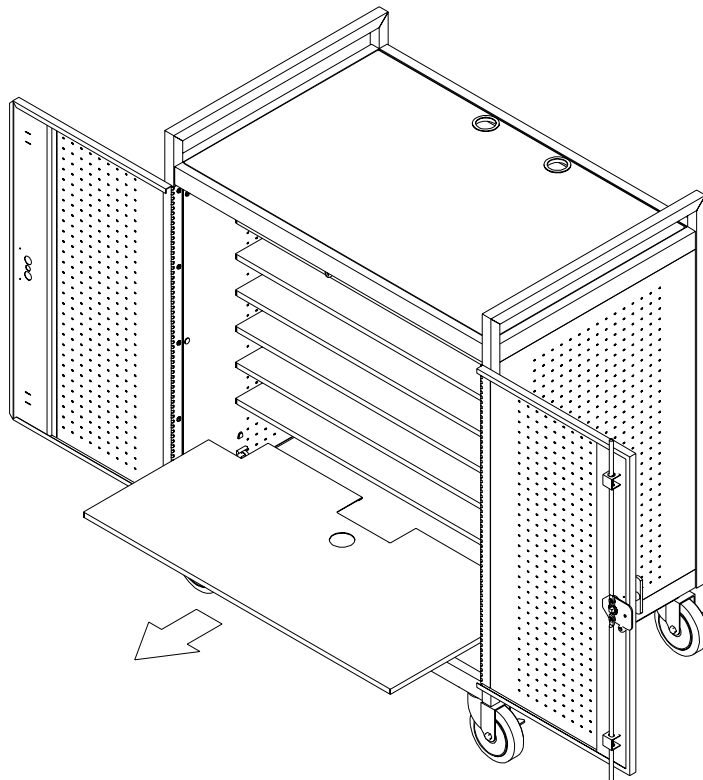
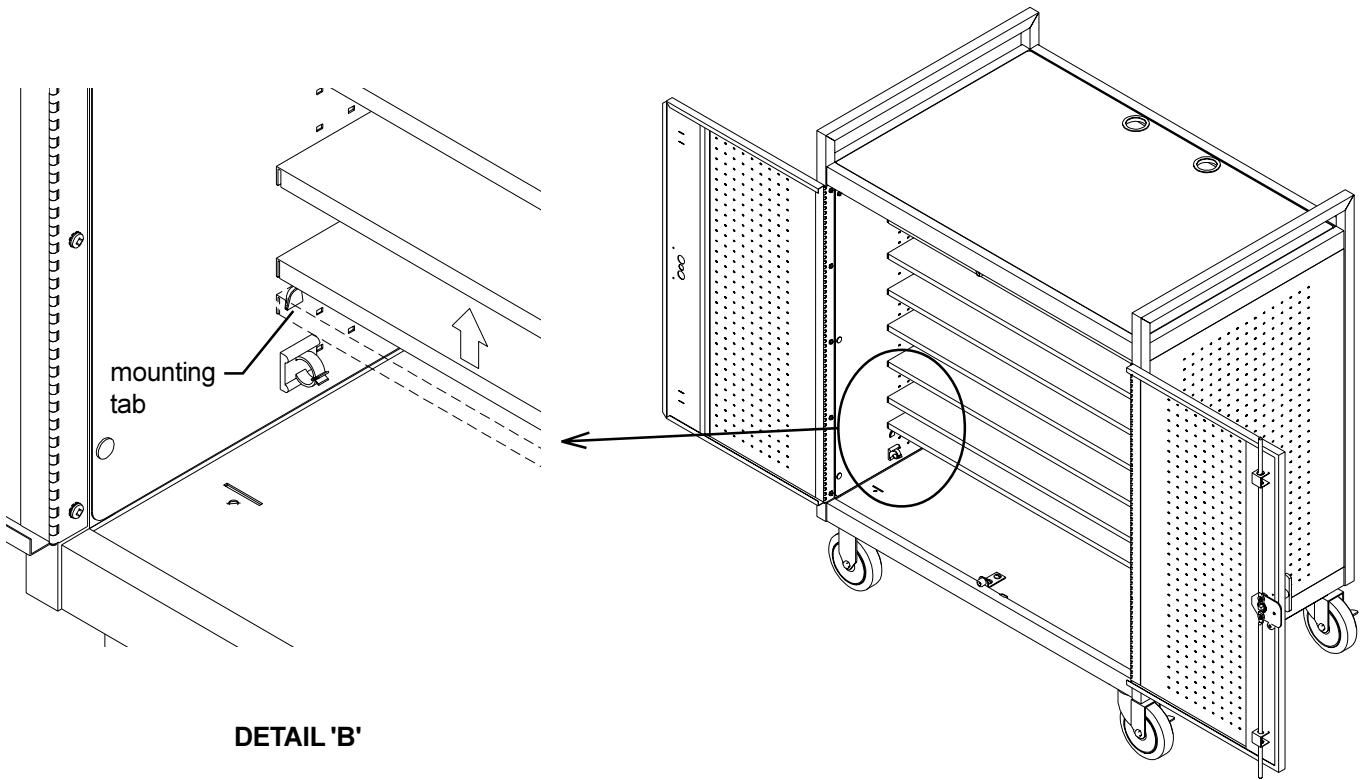

Step 4

With both doors open, remove the 3 bottom interior shelves by carefully pushing upward (to release shelf from mounting tabs) shown in Detail 'B', then carefully sliding out. Set each shelf aside.

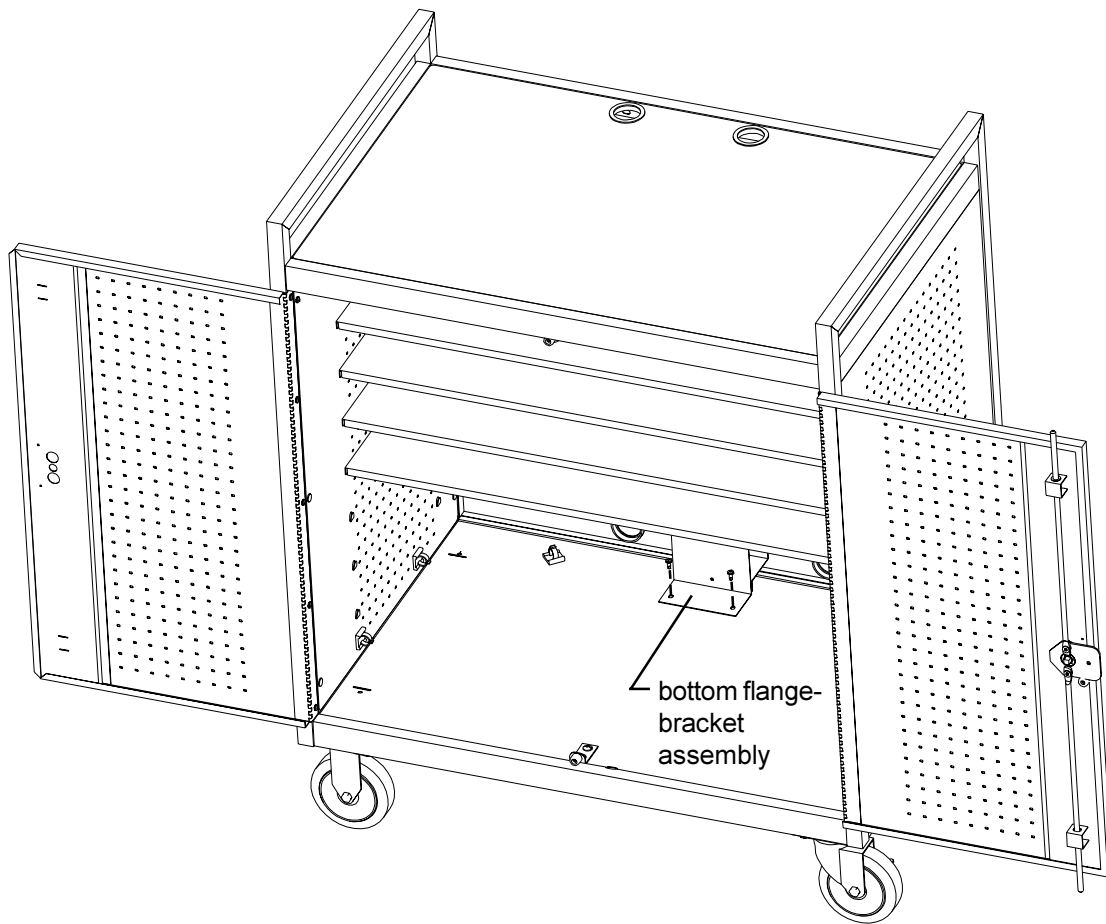

Step 5

Remove 2 screws from bottom flange (securing bracket to bottom of cart) and remove bracket assembly.

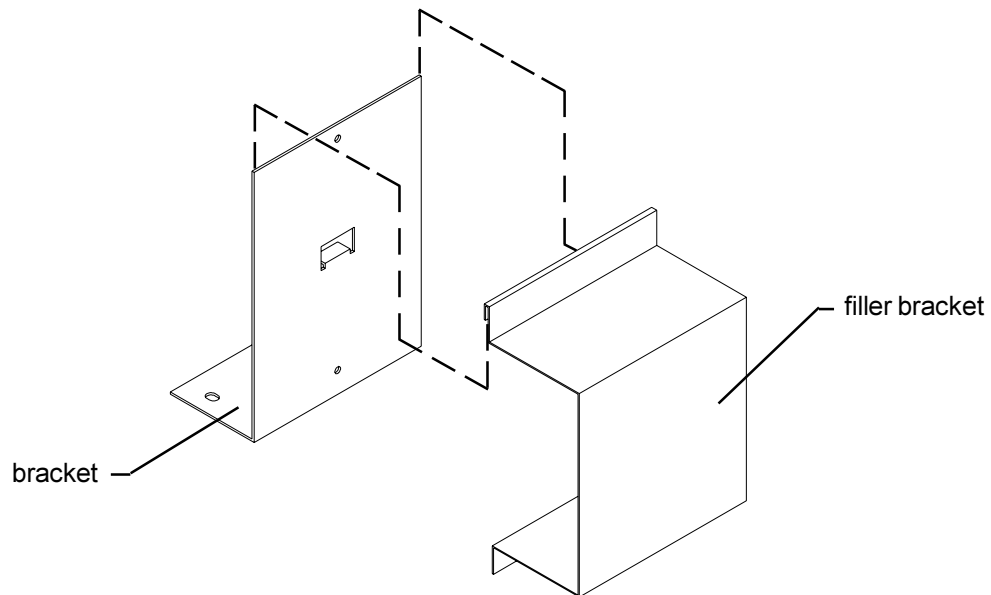

Step 6

Remove filler bracket from bracket by pulling upward. Discard filler bracket.

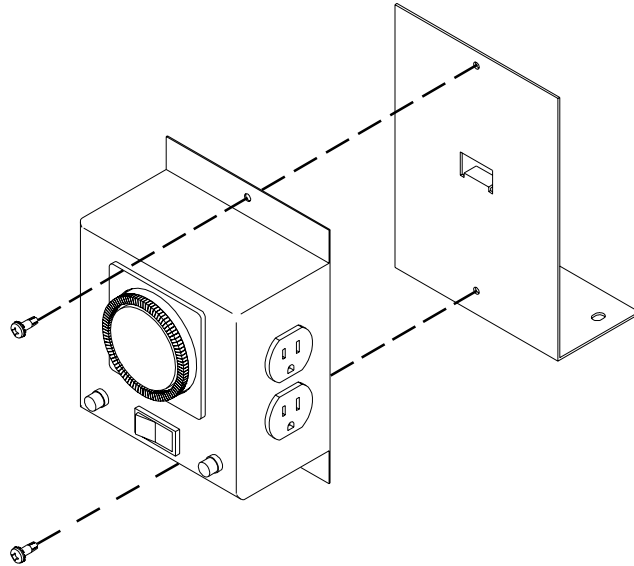

Step 7

Install timer with 2 screws. Adjust timer dial to current time. If necessary, adjust timer charging times to match the original timer.

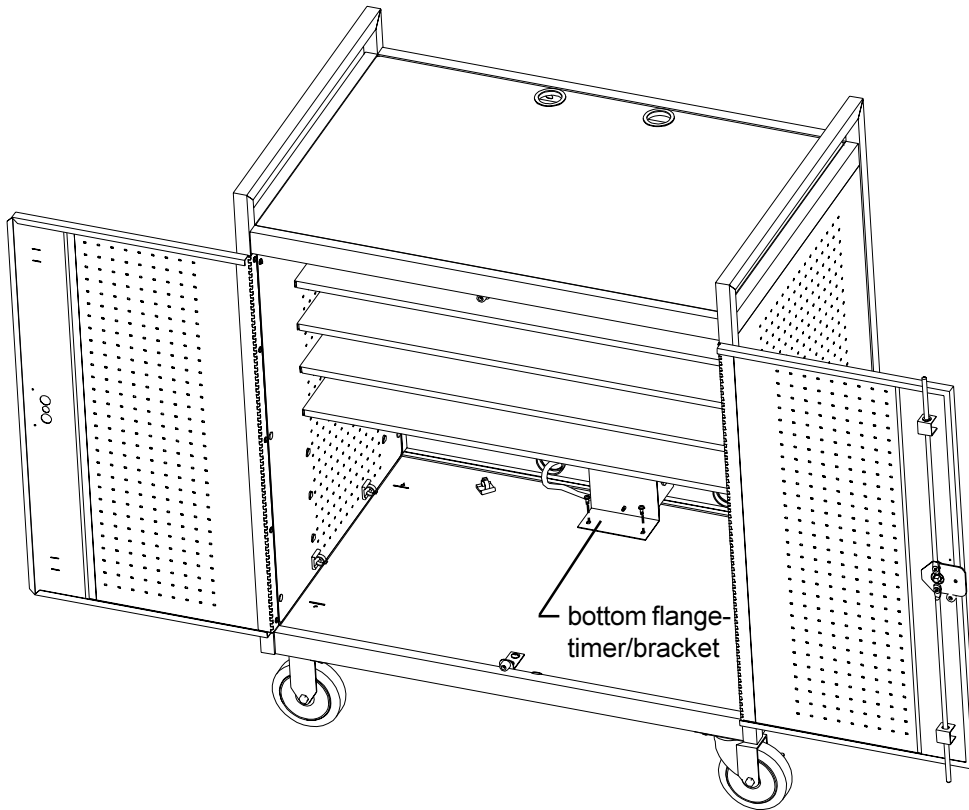

Step 8

Install timer/bracket assembly onto bottom, rear of cart with 2 screws. Feed the power cord from the timer out the grommeted round hole as shown. Make sure timer face is aligned with rear panel cutouts. Tighten screws.

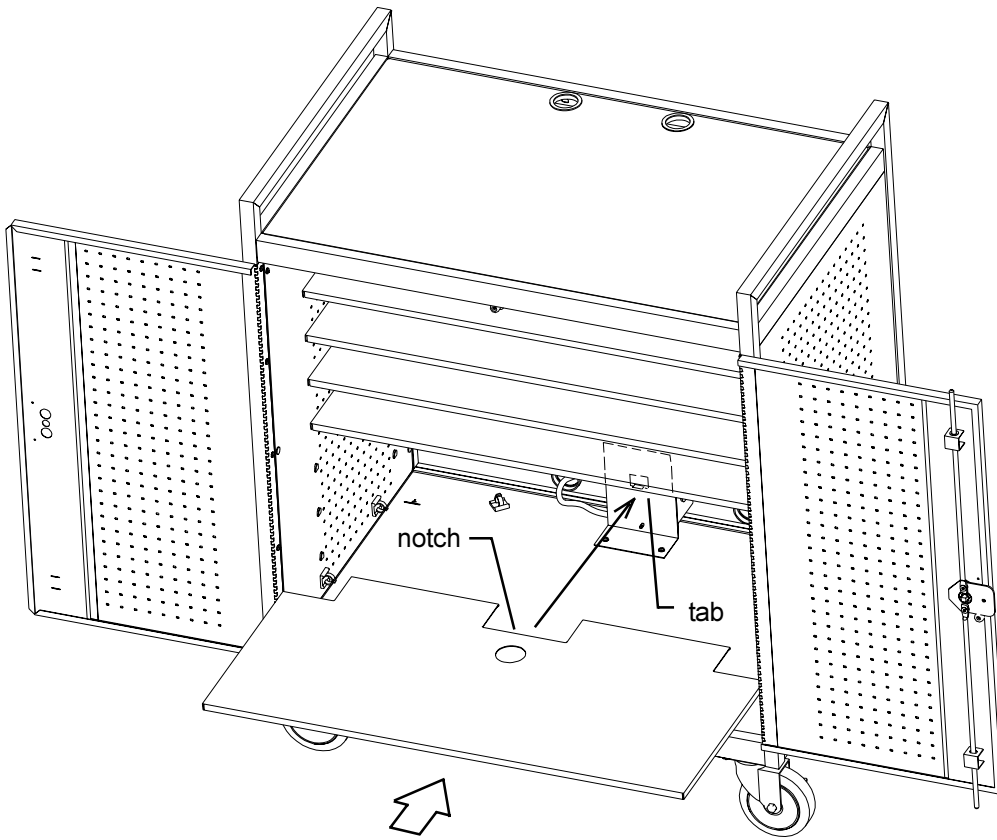

Step 9

Reinstall the 3 interior shelves as follows:

1. Carefully slide in the shelf with notch at the **bottom** position (the notch will rest on the bracket tab).
(Make sure that the shelf flanges are ALL seated into the mounting tabs.)
2. Slide in remaining 2 shelves into position as the bottom shelf.

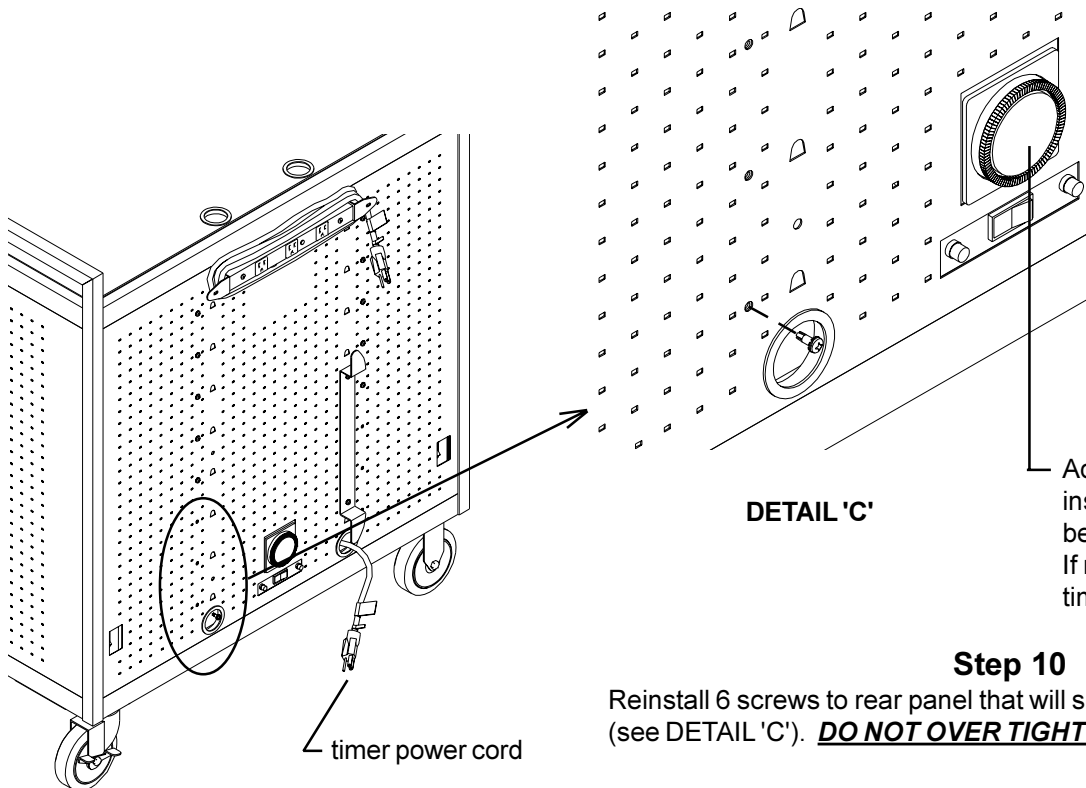

Adjust timer to current time when installation is complete and ready to be plugged back into power source. If necessary, adjust tabs for charging times.

Step 10

Reinstall 6 screws to rear panel that will secure the 3 interior shelves (see DETAIL 'C'). **DO NOT OVER TIGHTEN SCREWS.**

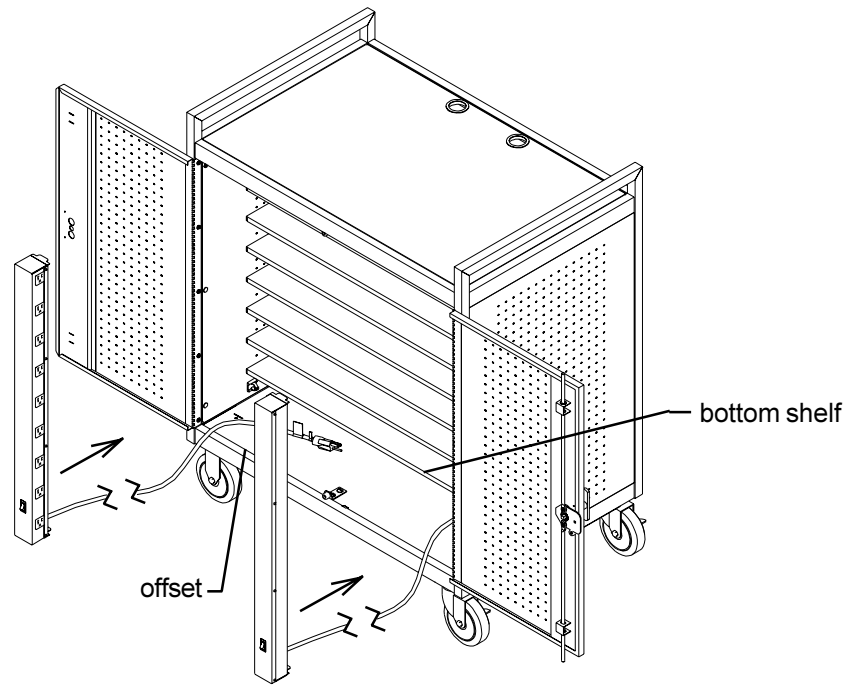

Step 11

Carefully reinstall E-Units into position by placing bottom in first, set against offset of bottom panel (of cart) and tilting it in sideways to the top.

When repositioned correctly, the E-Units outlets face the interior and power switch should face the front.

Reinstall the E-Unit bracket assemblies (make sure that the top flange of the E-unit is aligned with the slot in the bracket assembly) and tighten screws securely.

Feed the power cords (plug end) all the way through the bottom rear round cutouts (next to bracket assembly).

Press each E-Unit power cord into the two wire clips located on the side panel, bottom.

Wind power cords around the cord wrap bracket located above each round cutout for storage.

Do not use the rear, bottom wire clip.

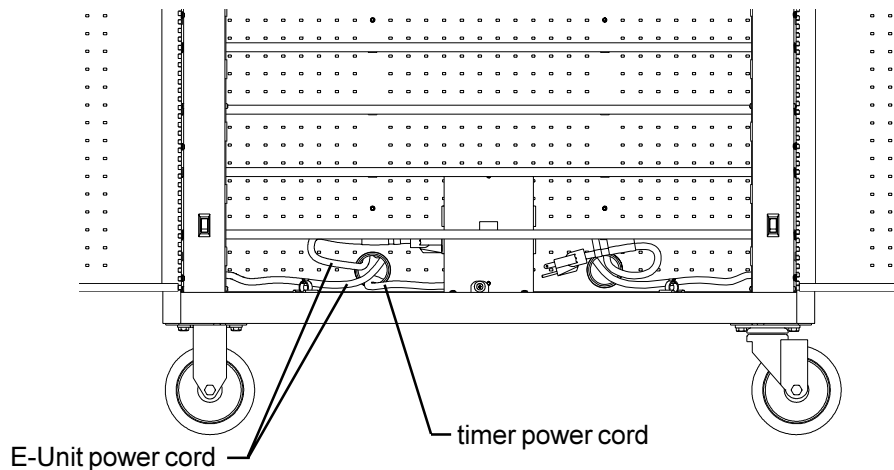

Figure 2

Unwind enough E-Unit power cord from the cord brackets on the rear panel to feed back through each grommeted hole and into the timer. Plug one E-Unit power cord into the bottom outlet of the timer marked 'A' only and the other E-Unit power cord into the bottom outlet of the timer marked 'B' only. See figure 2.

DO NOT PLUG BOTH E-UNIT POWER CORDS INTO ONE SIDE MARKED 'A' OR 'B' OUTLETS. THIS WILL CAUSE AN OVER-LOAD DURING THE CHARGING PROCESS.

Installation is now complete and ready for use.

LABEL INSTALLATION:

peel off and attach corresponding labels to shelves and E-Units.

AUX. 1	AUX. 2	AUX. 3	AUX. 4
AUX. 5	AUX. 6	1	2
3	4	5	6
7	8	9	10
11	12	13	14
15	16	17	18
19	20	21	22
23	24	25	26
27	28	29	30

suggested installation of labels

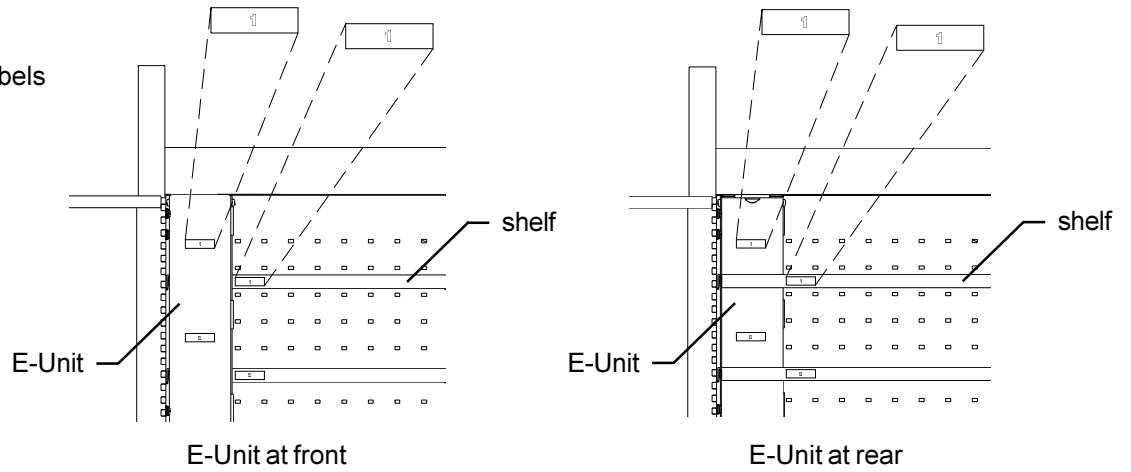

suggested label direction

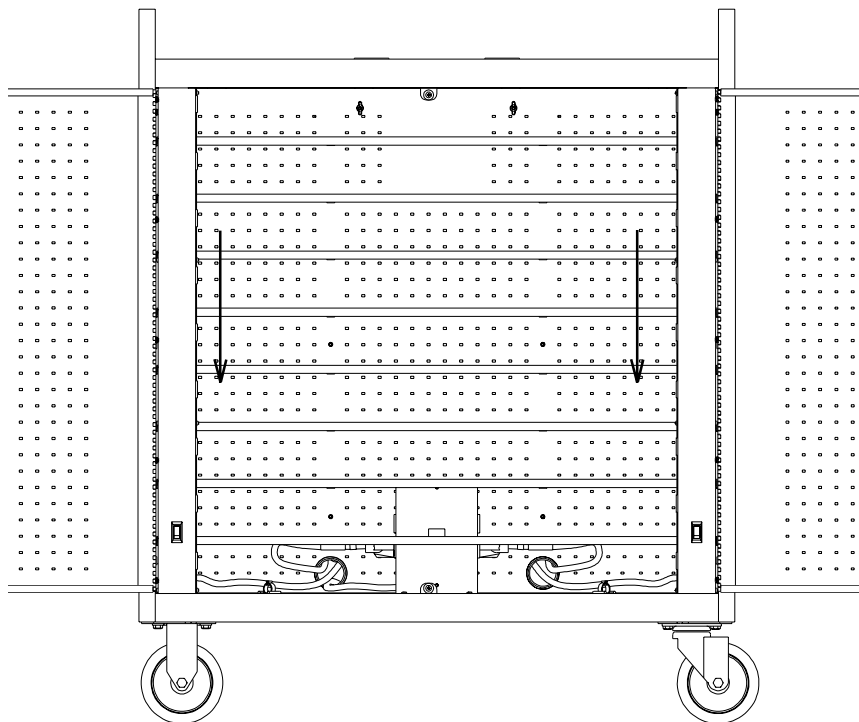

PAD LOCK - DOOR:

Resettable Combination Padlock

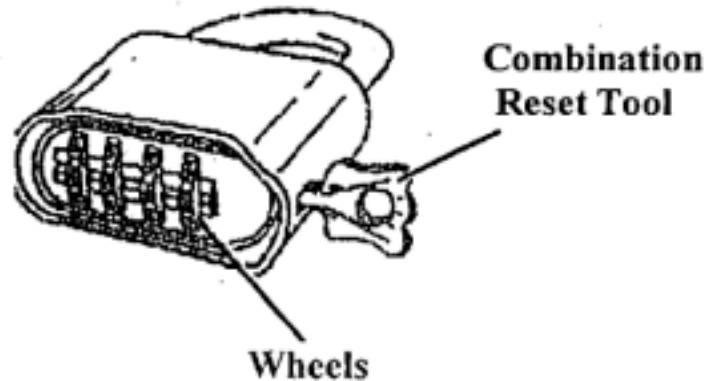

Open Lock The First Time

- 1) Set the combination to 0-0-0-0
- 2) Depress shackle and pull open.

To Set Your Own Combination

- **REMEMBER:** Combination can only be set when lock is open.
- 1) Insert "reset" tool (included in package) in hole on side of lock.
 - 2) Push key in and turn key 90 degrees in either direction.
(Key automatically stays in this position).
Failure to exert force while pushing key in will result in a failed attempt to set or reset combination.
 - 3) Set wheels to desired combination.
 - 4) Turn and remove reset tool. Lock is now set to new combination.
****BE SURE TO RECORD YOUR COMBINATION.**
 - 5) To lock scramble the wheels and close the shackle.
 - 6) To reopen dial your combination and depress shackle.

Bretford
11000 Seymour Avenue
Franklin Park, IL 60131
TEL: 847.678.2545
800.521.9614
FAX: 847.678.0852
800.343.1779

Bretford Ltd.
Technology House
7 Lake End Court, Taplow
Bucks SL6 0JQ England
TEL: 01628 603558
FAX: 01628 604923

www.bretford.com

Part#031-6607
Rev. 08.29.05 CH