

Affordable, Smart TVs to Engage Audiences in a Variety of Environments



These 70" Class (69.5" diagonal) and 60" Class (60.1" diagonal) Sharp commercial LED smart TVs combine full-HD image quality and stylishly thin profiles with a built-in digital tuner for the ultimate display experience. The LC-70LE661U and LC-60LE661U commercial LED smart TVs are perfect for sports bars, retail stores and other businesses that need to grab the attention of viewers for a new level of engagement.

Superb Image Quality

LC-70LE661U and LC-60LE661U commercial LED smart TVs have cutting-edge picture technology that deliver amazing detail, gorgeous color depth and consistent image quality. The advanced pixel structure of the panels enables stunning 4 million : 1 dynamic contrast for deeper blacks and whiter whites. The smart TVs also feature the AquoMotion™ 240 Refresh Rate that delivers precision clarity during fast-motion scenes.

Thin, Lightweight Design

LC-70LE661U and LC-60LE661U commercial LED smart TVs owe their thin profiles to edge-lit LED backlighting. Streamlined for a pleasing appearance and minimal protruding parts, these monitors weigh only **78.3 lbs** and **75 lbs**, respectively, with a bezel thickness of only 0.4" making for easy placement in offices, public places, stores and other commercial establishments.



Enhanced Connectivity

Three (3) HDMI® inputs let you connect multiple HD sources like digital signage and cable boxes. A powerful RS-232C command set permits flexible remote control capabilities from connected devices. A built-in USB port lets you present a variety of digital content including photos, music and video.

Unique Wallpaper Mode

When the unit is turned off, **Wallpaper Mode** lets you display virtually any image you choose on the screen at a reduced light level that mirrors museum conditions, so your screen blends beautifully into your installed environment—all at extremely low power.

Bigger Screen, Slimmer Bezel

The 70" Class model has a 14 percent greater viewing area than a 65" Class screen, and the 60" Class model has 20 percent more viewing area than a 55" Class screen.* In addition, its super-slim bezel measures just 0.4".

* Based on data available as of July 1, 2014.

** Additional fees and/or subscriptions may apply.

*** Internet service required. Not all services available in all areas. Some services require subscription.

Superb Support

A limited on-site commercial three-year warranty, plus Sharp's best-in-class customer support service is included.

Crystal Clear Sound

Powerful 20W audio features high fidelity so all of your scenes sound as breathtaking as they look.

Integrated Smart Apps

Working through built-in Wi-Fi®,** **SmartCentral™ Apps** lets you quickly and wirelessly connect to all the best apps, including a web browser. Gain instant access to movies with Netflix®, videos with YouTube®, music with Pandora®, photos with Flickr® and Picasa® and social apps like Facebook™.*** The **Remote Control App** allows you to change channels, volume, inputs, or power on/off and even adjust picture settings. In addition, the commercial LED smart TVs are **web browser-enabled** to visit all your favorite sites in a larger-than-life window.

Specifications

Model Name	LC-70LE661U	LC-60LE661U
Installation	Landscape	
LCD Panel	70" Class (69.5" diagonal) TFT LCD	60" Class (60.1" diagonal) TFT LCD
Max. Resolution	1,920 x 1,080 pixels	
Max. Display Color (approx.)	1.06 billion colors	
Pixel Pitch (H x V)	0.8015 x 0.8015 mm	0.693 x 0.693 mm
Max Brightness*1	300 cd/m2	
Contrast Ratio	5000:1	
Dynamic Contrast Ratio	4,000,000:1	
Viewing Angle (H/W)	176°/176° (CR 10)	
Active Screen Area (W x H)	60.6" x 34.0"	52.4" x 29.5"
Response Time	4 ms (grey to grey, avg.)	
Backlight	LED, edge lit	
Computer Input	Video HDMI, Analog RGB	
Synchronization	Horizontal/vertical separation (TTL: positive/negative), Sync on green, Composite sync (TTL: positive/negative)	
Plug & Play	VESA DDC2B	
Power Management	VESA DPMS	
Video Color System	NTSC-M/PAL-N/PAL-M	
Analog/Digital Tuner	NTSC/ATSC	
Input Terminals	HDMI x 3, Mini D-sub 15-pin x 1, Component Video RCA (Y, Cb/Pb, Cr/Pr) x 1, Composite Video RCA pin x1, RCA pin (L/R) x2, 3.5 mm-diameter mini stereo jack x 1, RS-232C x 1, ANT/Cable x 1, USB x1	
Output Terminals	Audio: RCA pin (L/R) x1, Digital audio output (optical) x 1	
Input/Output Terminals	Ethernet RJ-45 x 1	
Speaker Output	10W + 10W	
Power Supply	100V - 240V AC, 50/60 Hz	
Power Consumption	180 W	150 W
Environmental Conditions	Operating Temperature 0°C to 40°C Operating Humidity 30% to 80% RH (no condensation)	
Dimensions (W x D x H (approx.) (display only)	61-35/64" x 3-7/16" x 35-53/64"	53-23/64" x 3-25/64" x 31-3/16"
Weight (approx.)	75 lbs.	52.9 lbs.

Dimensions

LC-70LE661U

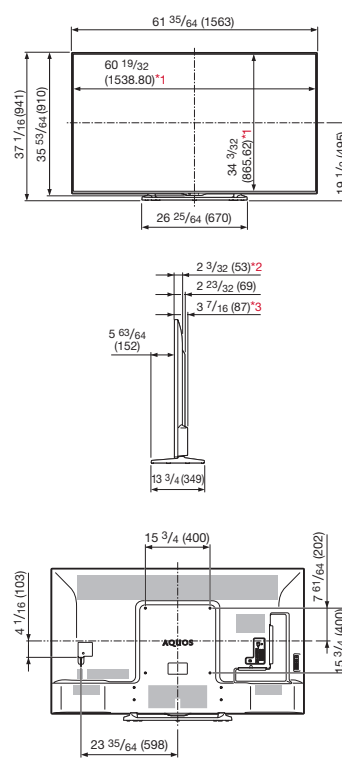

LC-60LE661U

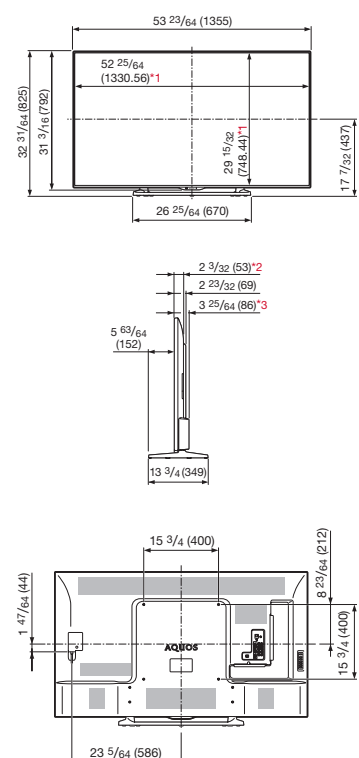

Unit: inch (mm)

*1 Active area, *2 Thinnest part, *3 Including projecting parts

Distributed by:



SHARP ELECTRONICS CORPORATION
1 Sharp Plaza, Ste.1, Mahwah, NJ 07495-1123
1-800-BE-SHARP • www.sharpsusa.com

205 Westwood Ave, Long Branch, NJ 07740
Phone: 866-94 BOARDS (26273) / (732)-222-1511
Fax: (732)-222-7088 | E-mail: sales@touchboards.com

Product specifications and designs are subject to change without notice. Sharp, AquoMotion and SmartCentral are trademarks or registered trademarks of Sharp Corporation and/or its affiliated entities. Wi-Fi is a registered trademark of the Wi-Fi Alliance, the official governing body for promoting Wi-Fi technology on a worldwide level. Netflix is a registered trademark of Netflix, Inc. Pandora is a registered trademark of Pandora Media, Inc. YouTube and Picasa are registered trademarks of Google, Inc. Flickr is a registered trademark of Yahoo! Inc. Facebook is a trademark of Facebook, Inc. HDMI and High-Definition Multimedia Interface are trademarks or registered trademarks of HDMI Licensing LLC in the United States and other countries. The ENERGY STAR logo is a certification mark and may only be used to certify products that have been determined to meet the ENERGY STAR program requirements. ENERGY STAR is a US registered mark. The ENERGY STAR guidelines apply to products only in the US, the EU, Japan, Canada, Australia, New Zealand, and Taiwan All other trademarks are property of their respective owners. All screen images appearing in this brochure are simulated.

