



TRX-8180

Heavy Duty Diagonal Cutter with Dual-Component Handle 4.5 mm







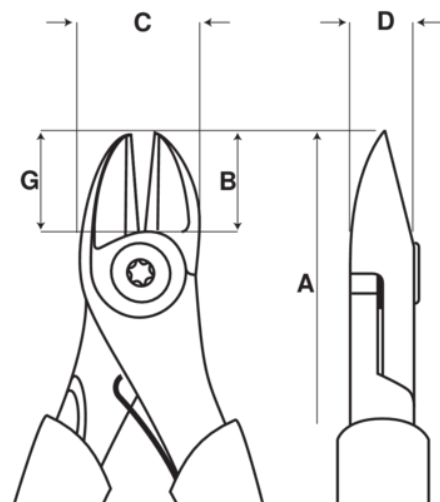





PRODUCT DETAILS

- Handles with two-component combination, thermoplastic surface on tough polypropylene provides superior grip
- Progressive bevel cutting edge: The cutting bevel progresses along the edge in order to cut soft and thin material at the tip and hard and thick material close to the joint
- Tough design is ideal for production, maintenance, repair and service applications
- Rivet joint minimizes friction and maximizes jaw alignment
- Cutting edges hardened to 63–65 HRC for durable performance
- High leverage joint to reduce cutting force
- Equipped with a return spring featuring an on/off function
- High performance alloy steel
- Burnished finish and anti-corrosion treated



PRODUCT ATTRIBUTES

Product: **TRX-8180**

	Oval		L	A	210.0 mm
A	8.26 in	B	21 mm	B	0,82 in
C	29 mm	C	1.141 in	D	11 mm
D	0,433 inch		4.5 mm		0.177 in
	3.0 mm		0.118 in		2.5 mm
	0.10 in		Progressive Bevel		304 g