

Carrier 30 Cart™ Specifications

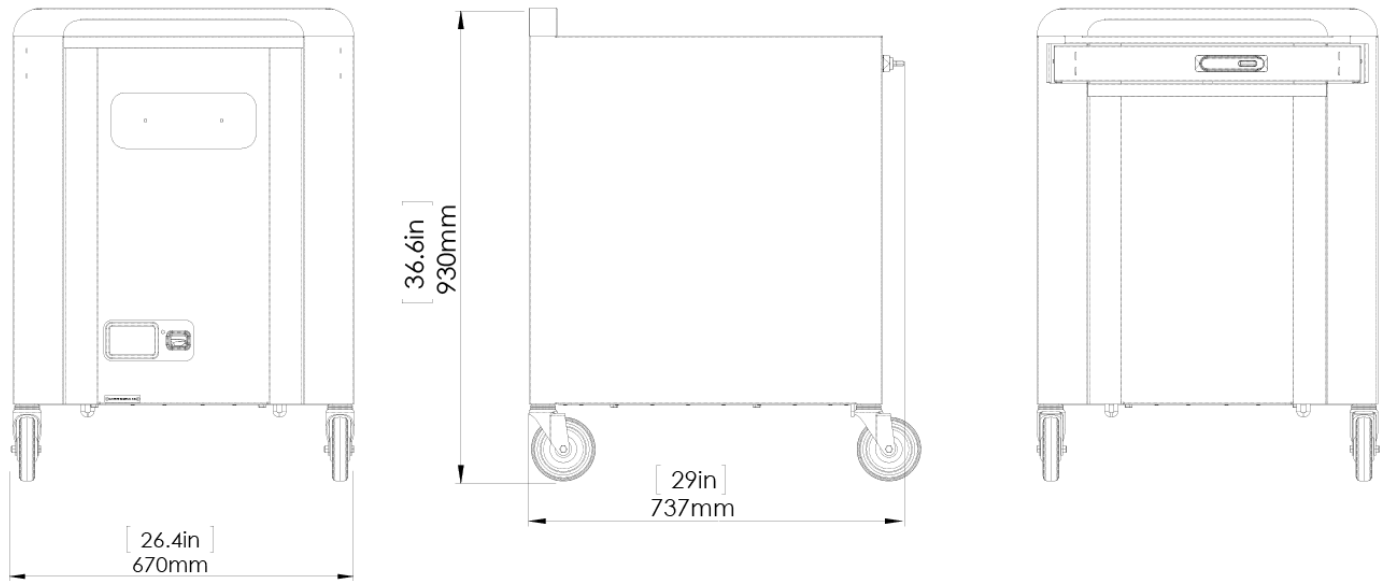

Charging

Charge up to 30 devices at once. Equipped with an ECO Safe Charge power management system, which automatically stages the availability of power to each device, reducing the possibility of a momentary electrical overload when multiple devices are powered on at the same time.

Large Baskets by LocknCharge (green, blue and red)

Internal slot dimensions

mm: 350(H) x 234.2(L) x 24(W)

inches: 13.78(H) x 9.22(L) x 0.94(W)

External basket dimensions

mm: 436.4(H) x 249.1(L) x 180.5(W)

inches: 17.18(H) x 9.81(L) x 7.11(W)

Accessories

Includes; Lock-down kit, combination padlock, padlock silicone case, device mat, velcro cable ties and numbered stickers. Device Racks are available to use when the devices are too big to fit inside Large Baskets by LocknCharge. Install 2 Racks per Carrier 30 Cart to accommodate larger Chromebooks and Laptops.

Warranty¹

Lifetime on chassis

Two years on electrical

12 months on components

Power

Input 110~240 VAC

Output: 240V ~ 50Hz Max load 10 Amps

Includes Surge Protection

Color

Ripple finish powder coat:

Charcoal core with a white sliding top

Construction

Welded steel for strength and durability

External dimensions

mm: 737(L) x 670(W) x 930(H)

inches: 29(L) x 26.4(W) x 36.6(H)

weight: 71.5 kg | 157.6 lbs

Certifications

CE (Europe)

SAA (Australia)

ETL Listed (USA)

UL Compliant (USA)

www.lockncharge.com

Phone: +44 (0) 208 441 4107

europesupport@lockncharge.com

