

STEP 5

Adjust the seat height: turn the broaching knob anticlockwise and pull it outward. Adjust the seat height according to your needs then release the knob; when the knob 'clicks' into the frame, the seat is secure in place. Now turn the knob clockwise to lock the cushion.

Position seat: turn the knob anti-clockwise to loosen the seat, then adjust the seat position, and turn the knob clockwise to tighten.

Press the buckle of the pedal to adjust the belt length.

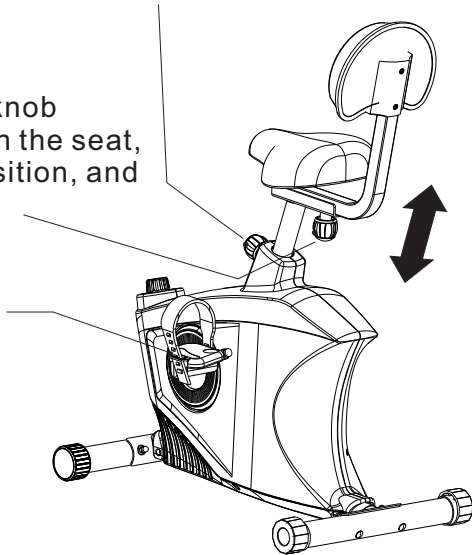

▲ Adjust the position and height of seat and pedals belts according to your needs. After finishing assembly, please ensure bike stability and safety before using!

ZOXOU INC.

ADDRESS: 47618 Kato Road, Fremont, CA, 94538 United States
TEL: 1-855-421-2808
Email: service@zoxouinc.com

FITLEADER

INSTALLATION GUIDE

Item No. U2

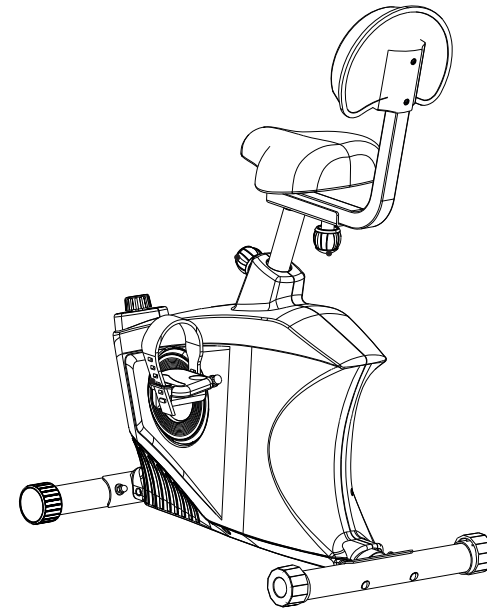

▲ CAUTION

Please read all instructions carefully before using this product. Retain this manual for future reference. The specifications of this product may vary slightly from the illustrations and are subject to change without notice.

WARNINGS

1. Make sure you read and fully understand this instruction manual.
2. It is the user's responsibility to read and understand all potential hazards of this exercise equipment.
3. Consult a physician before you begin a new exercise program. If you should experience pain, or you feel faint, short of breath or dizzy, stop exercising and consult a physician. Incorrect or excessive use of this machine can result in injury.
4. Your exercise bike should be operated on a stable, level surface.
5. You should mount and dismount your exercise bike carefully.
6. Loose clothing, untied shoelaces, jewelry and towels should be kept away from the bike pedals.
7. This machine is not a toy. Keep children away from this exercise bike, especially while in use. Children should be taught to never put their fingers near any moving parts on this machine.
8. To avoid spills on the machine, beverages used near this bike should be kept in a closed bottle such as a water or sports bottle.
9. Maximum weight capacity of this bike is 300 lbs (136 kg).

Ignoring the warnings in this manual could lead to hazardous situations that might result in serious injury or death.

STEP 4

Install the pedals (F) (E) to the crank legs and lock them firmly with the wrench side of the wrench / screwdriver (4).

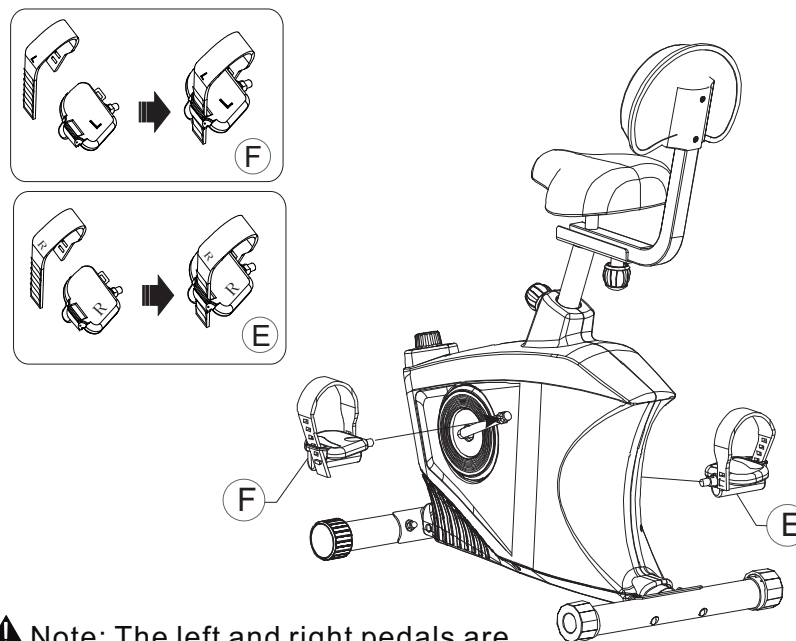

⚠ Note: The left and right pedals are different and must be installed on their corresponding sides of the bike.

STEP 2

Pull out the broaching knob and attach the seat frame (H) to the base of the bike (A). Then release the knob. You will hear a 'click' when the broaching knob is in place to stabilize the seat frame. Seat frame height is adjustable this way. Attach seat cushion (I) to the seat frame (H), then place washers (9) on knob shaft and lock the knob (K) into the seat cushion (I).

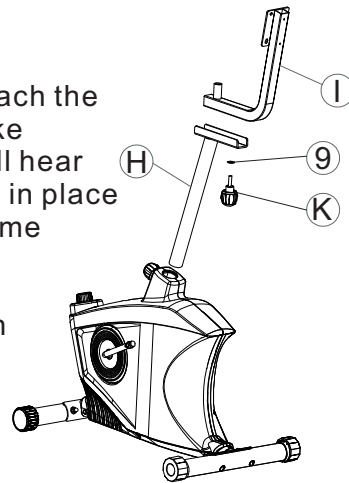





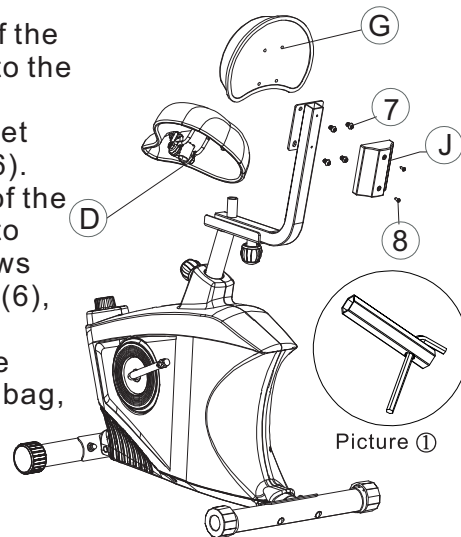



STEP 3

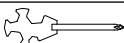







Take seat cushion (D) out of the packing bag, then attach it to the seat frame. Lock the seat cushion firmly with the socket spanner (5) and allen key (6). Take back cushion (G) out of the packing bag, then attach it to seat back frame using screws (7) tightened with allen key (6), and adjust its position. Take the cushion decorative cover (J) out of the packing bag, then lock the cover in place using wrench (4) and screws (8).

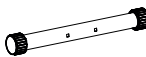
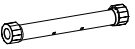

Accessory package list

Part	Part description	Name	Qty
1		M8 x 65mm	4
2		#8 x 19 round washers	4
3		M8 x 15mm nuts	4
4		Screwdriver (10, 13, 15, 17)	1
5		Socket wrench	1
6		Hex key 5x5mm	1
7		M8 x 12mm screws	4
8		M4 x 8mm screws	2
9		#8.5 x 20 washers	1

Part List

Part	Accessory	Qty	Part	Accessory	Qty	Part	Accessory	Qty
A		1	B		1	C		1
D		1	E		1	F		1
G		1	H		2	I		1
J		1	K		1			

Installation Diagram

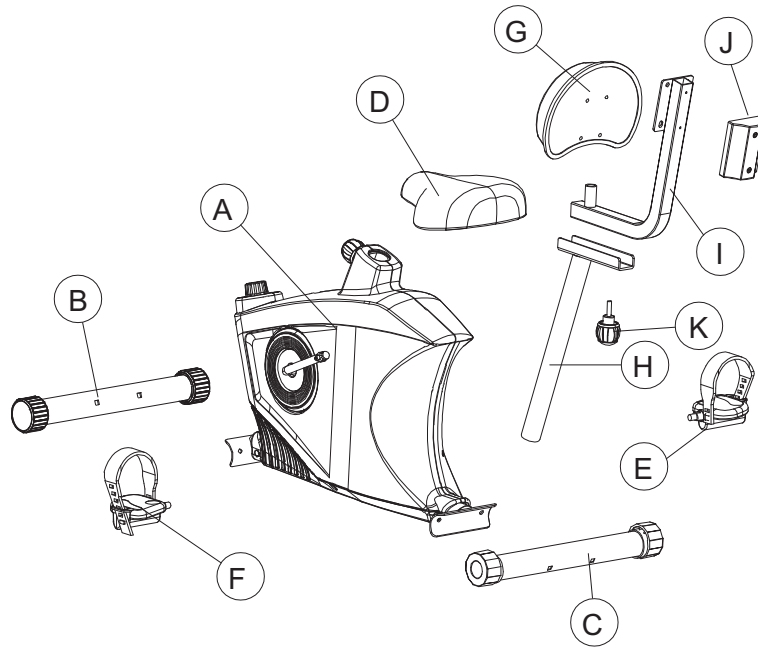

STEP 1

Place the cart (A) on the floor. Attach the front stabilizer (B) to the cart (A) using two head bolts (1) with two washers (2) and two nuts (3). Use the enclosed screwdriver (4). Next, attach the rear stabilizer (C) to the cart using two head bolts (1) and two washers (2) with 2 nuts (3).

