

Item No. D5D

Installation Guide

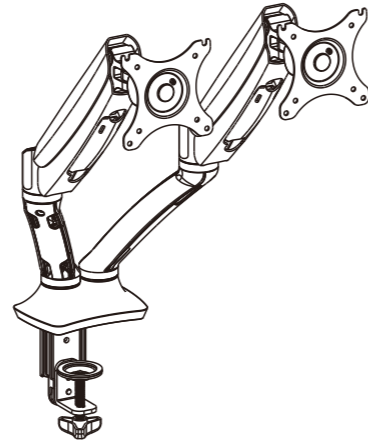
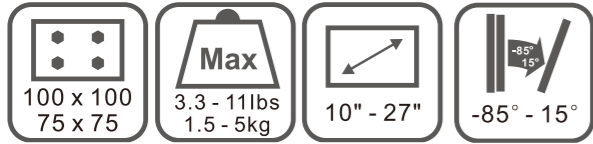

Package Contents

(A) Parts Included

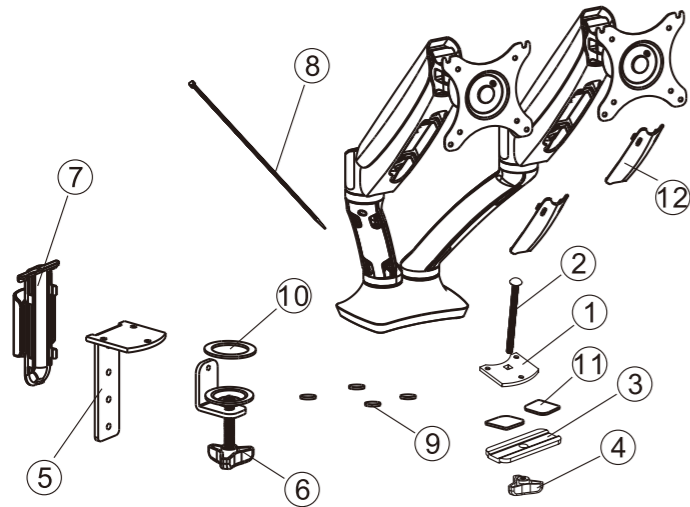

- ①. Bottom support 1 x 1 PC
- ②. Screw x 1 PC
- ③. Washer x 1 PC
- ④. Butterfly knob 1PC
- ⑤. Bottom support 2 x 1PC
- ⑥. Knob x 1PC
- ⑦. Cable cover 1 x 1PC
- ⑧. Nylon ties x 10 PCS
- ⑨. Anti-slip rubber 1 x 4 PCS
- ⑩. Anti-slip rubber 2 x 1 PC
- ⑪. Anti-slip rubber 3 x 2 PCS
- ⑫. Cable cover 2 x 2 PCS

(B) Screw Set and Tools

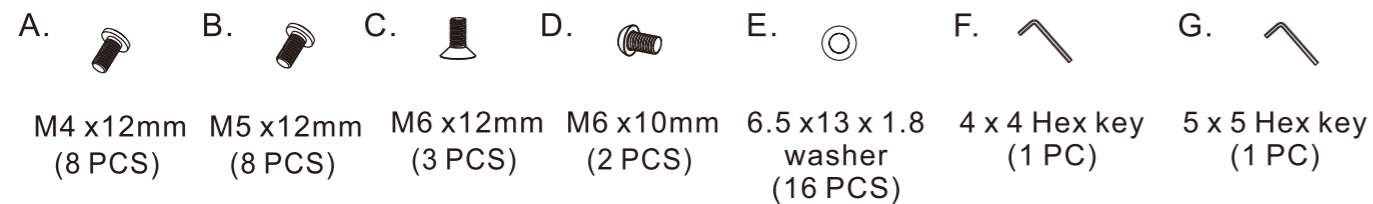

(C) Tools Needed for Assembly

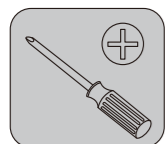

Installation Steps

STEP 1: Preparations before installing monitor

1. Verify that the monitor has holes at VESA spacings, either 100 x 100mm or 75 x 75mm. If it does not have this pattern, the monitor cannot be installed.
2. Remove the monitor's original fixed base. Be careful not to scratch the screen.

75 x 75 or 100 x 100 mm spacing

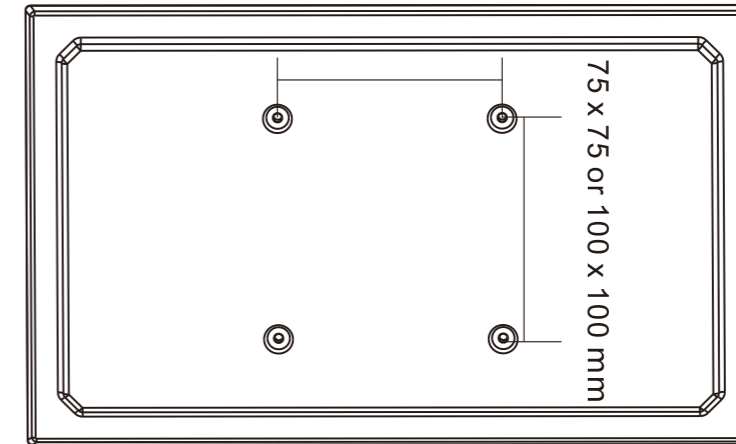

STEP 2 - Option A: Install bracket on desk using clamp

This option is for desks without a grommet hole.

1. Attach the bottom support 2 (5) to the tube by tightening screws (C) with 4 x 4mm hex key (F).
2. Turn the mount upside-down and put anti-slip rubber 1 (9) onto the bottom support 2 (5).
3. Put anti-slip rubber 2 (10) onto the top of knob (6).
4. Attach the knob (6) to the bottom support 2 (5) using screws (D) with 4 x 4mm hex key (F).
5. Position the bottom clamp against desk surface and fully tighten clamp knob (6).
6. Place the cable cover 1 (7).

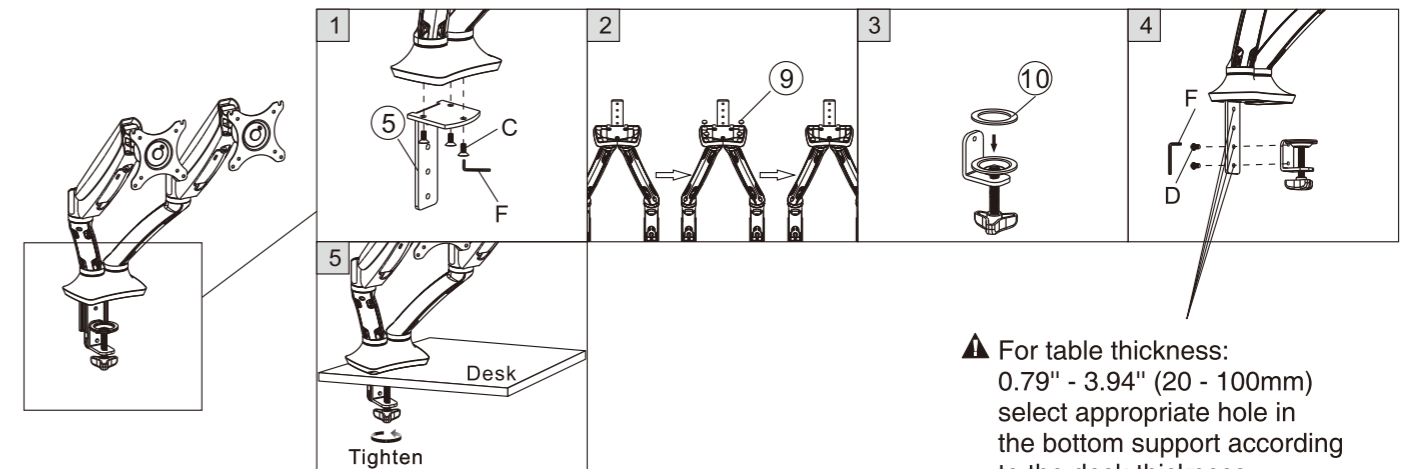

▲ For table thickness:
0.79" - 3.94" (20 - 100mm)
select appropriate hole in
the bottom support according
to the desk thickness.

STEP 2 - Option B: Grommet

This option is for desks with a grommet hole.

1. Insert the screw (2) into the hole of the bottom support 1 (1).
2. Attach the bottom support 1 (1) to the base by tightening screws (C) with 4 x 4mm hex key (F).
3. Turn the mount upside-down and put anti-slip rubber 1 (9) onto the bottom support 1 (1).
4. Insert the bottom support into the desk hole.
5. Attach anti-slip rubber (11) on to the washer (3).
6. Screw in the washer with the butterfly knob (4).

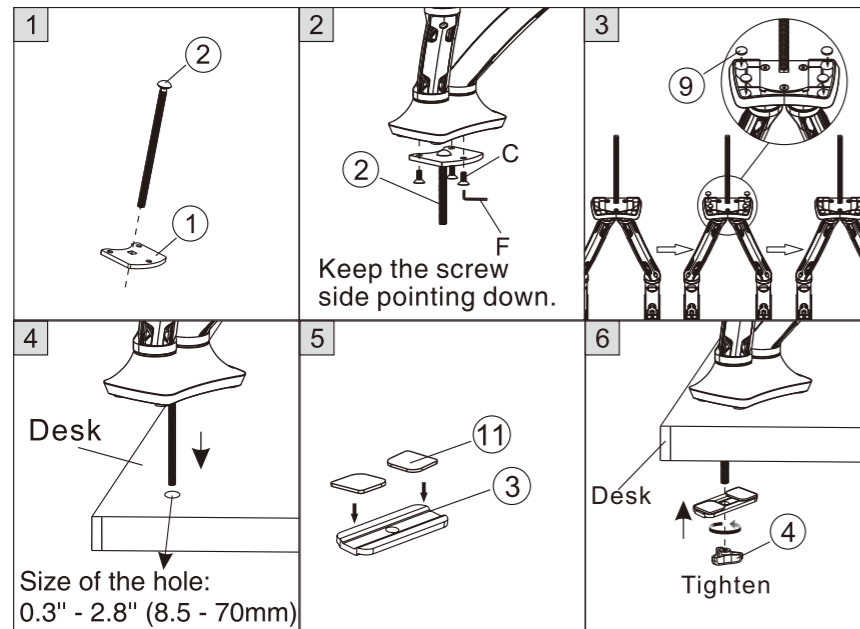

▲ For table thickness:
0.79" - 3.54" (20 - 90mm)

STEP 3 : Attach the monitor the plate

1. Add washers (E) to appropriate screws (A or B) - depending on monitor hole size.
 2. Attach monitor to arm using the screws (A or B). For 100mm x 100mm VESA holes, first attach top screws to monitor and set monitor into top grooves of monitor plate (2).
 3. Then add bottom screws through monitor plate and securely tighten all four screws.
- Note: For 75mm x 75mm VESA holes attach all four screws through monitor plate and tighten securely.

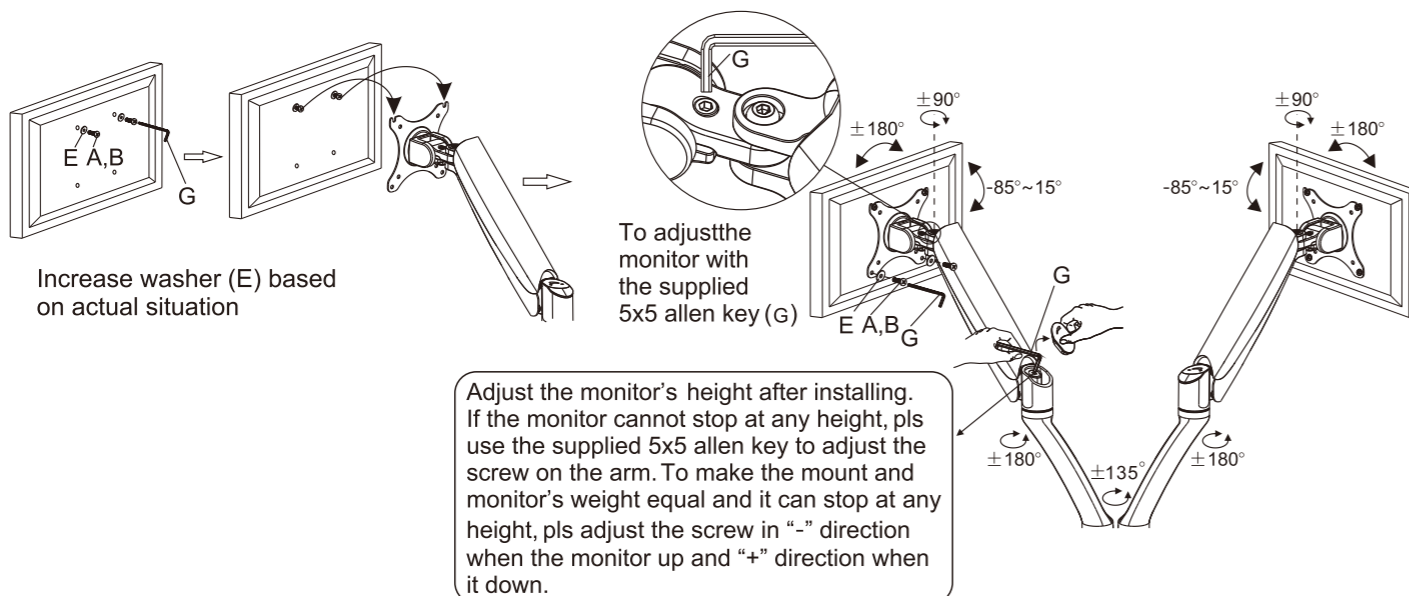

Adjust the monitor's height after installing. If the monitor cannot stop at any height, pls use the supplied 5x5 allen key to adjust the screw on the arm. To make the mount and monitor's weight equal and it can stop at any height, pls adjust the screw in "-" direction when the monitor up and "+" direction when it down.

STEP 4: Using cable management

1. Manage the cables with nylon ties (8).
2. Take off the cover and slide cables through the underside of the arm and tighten the cover with screw.
3. Pass the cable along the slot and place cable cover 2 (12).

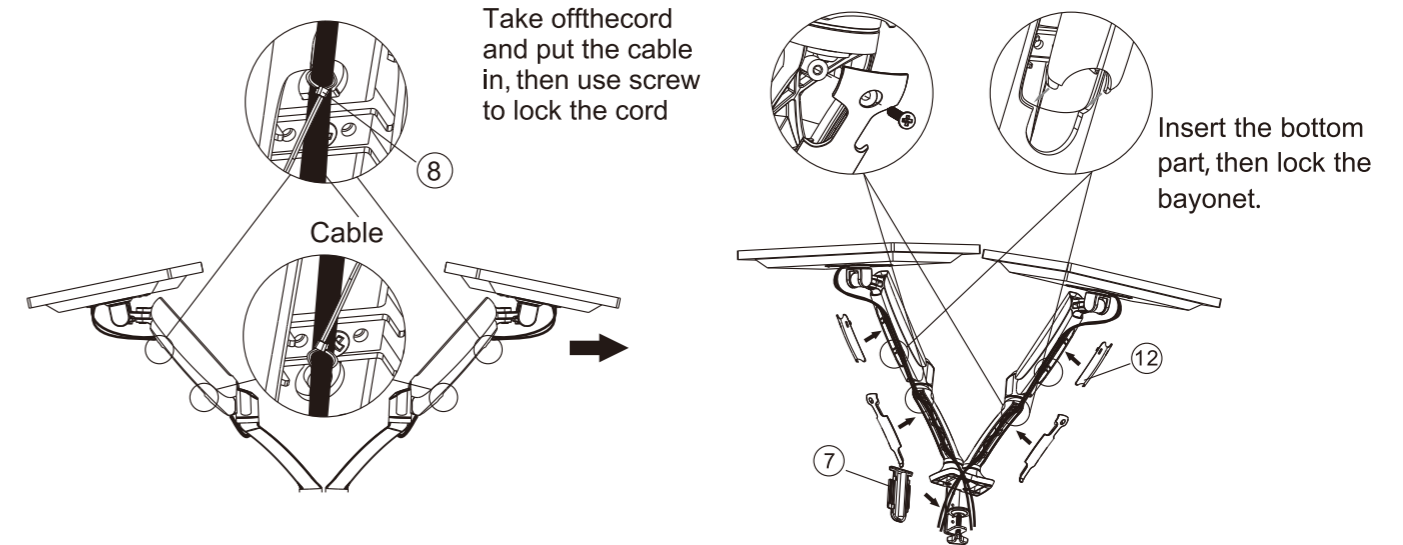

CAUTION

This product contains small items that could be a choking hazard if swallowed. Keep these items away from young children.

- Make sure these instructions are read and completely understood before attempting installation. If you are unsure of any part of this installation, please contact a professional installer for assistance.
- The desk or mounting surface must be capable of supporting the combined weight of the mount and the monitor, otherwise the structure must be reinforced.
- Proper tools must be used. A minimum of two people are required for this installation. Failure to install properly can result in property damage.
- Check joint parts every two months, making sure the screws have not loosened.

This product was designed to be installed on a desk. Before installing, make sure the mount will support the combined load of the equipment and hardware. Never exceed the maximum load capacity 11 lbs (5 kg), or else it may result in product failure.

Note: This product is intended for indoor use only. Use of this product outdoors could lead to product failure.

ZOXOU INC. (Distributor)

ADDRESS: 4569 Las Positas Rd. Suite A. Livermore, CA 94551 United States

TEL: 1-855-421-2808

Facebook: Loctek

Twitter: LoctekOfficial

Website: www.loctek.us

www.pricedepot.com

LOCTEK ERGONOMIC TECHNOLOGY CORP. (Manufacturer)

ADDRESS: No. 588 Qihang South Road, Binhai Industrial Zone, Yinzhou District, Ningbo China

Website: www.loctek.com

