

Item No. R2L
Installation Guide

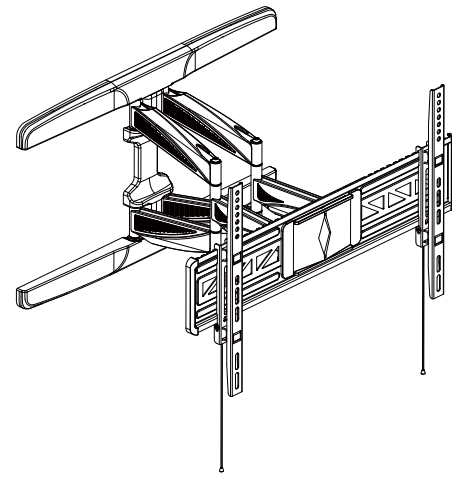

Package Included:

(A) Parts Included:

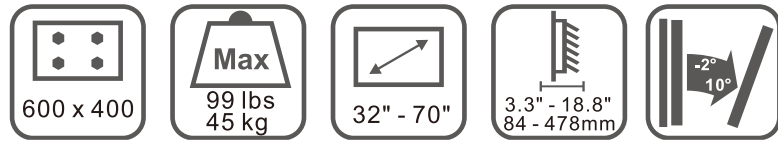
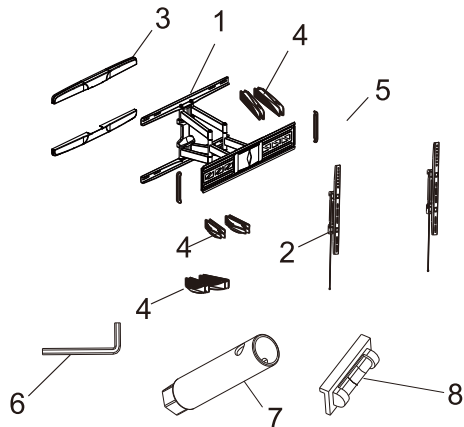

1. Wall plate
2. TV mounting rail x 2
3. Plastic cover
4. Cable management clip x 2
5. Decorative end cap x 2
6. 5 x 5 allen key
7. Box wrench
8. Bubble level

(B) TV Attachment Screw Set:

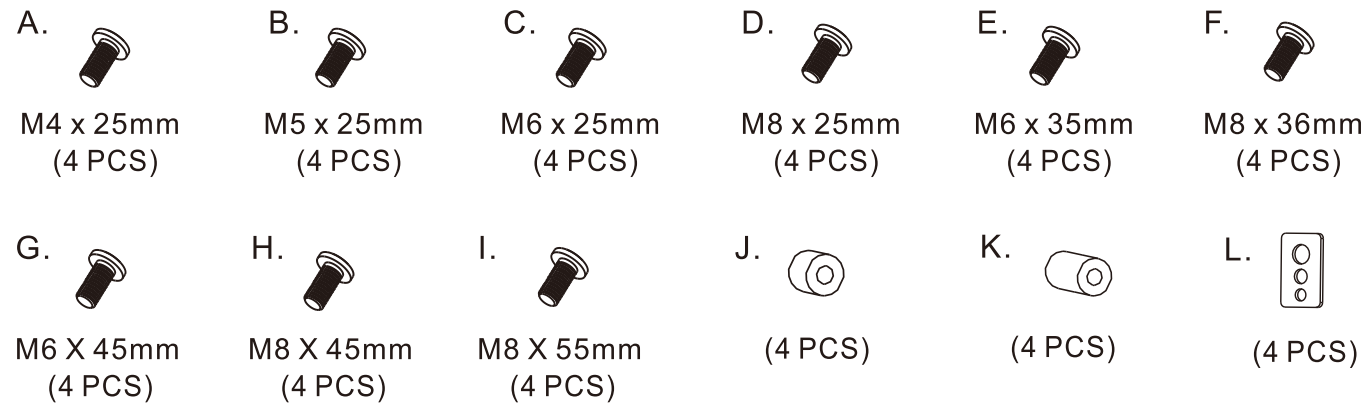

(C) Wall Mounting Screw Set:

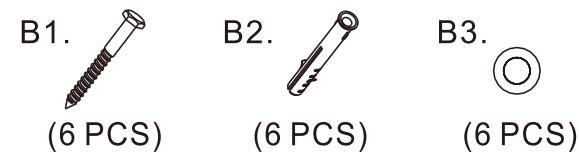

(D) Tools Needed for Assembly:

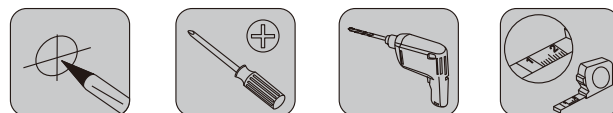

Installation Steps:

STEP 1: Alternative A - Mounting on Solid Concrete

1. Hold mount against wall and make six marks where you will insert the screws.
2. Drill six holes into the wall where you made the marks. The diameter of the drill bit should be 3 / 8" (10mm). The depth of the holes drilled should be 2.36" (60mm).
3. Install the screw anchors (B2) into the wall. Then secure the mount to the wall using screws (B1) with washers (B3).

Keep the gear up when mounting the product to the wall.

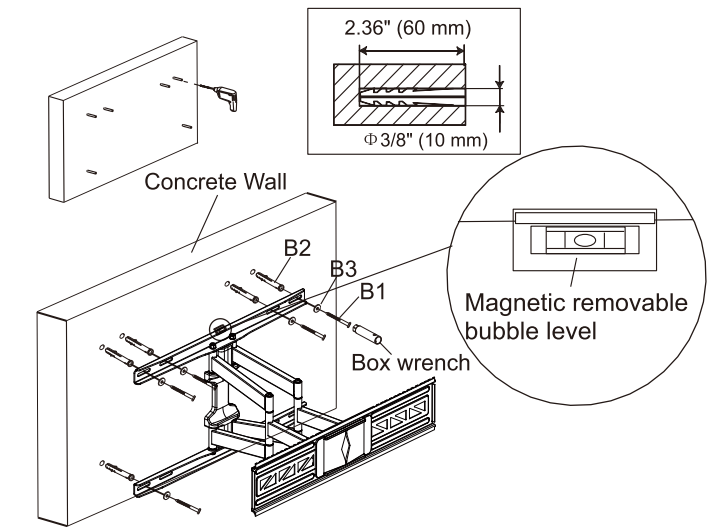

STEP 1: Alternative B - Mounting on Wood Studs

1. Identify where the studs in your wall are. Hold mount against wall and make four marks on the studs where you will insert the screws. (Two marks per stud.)
2. Drill four holes into the wall where you made the marks. The diameter of the drill bit should be 3 / 16" (5mm). The depth of the holes drilled should be 2.36" (60mm).
3. Secure the mount to the wall using screws (B1) with washers (B3).

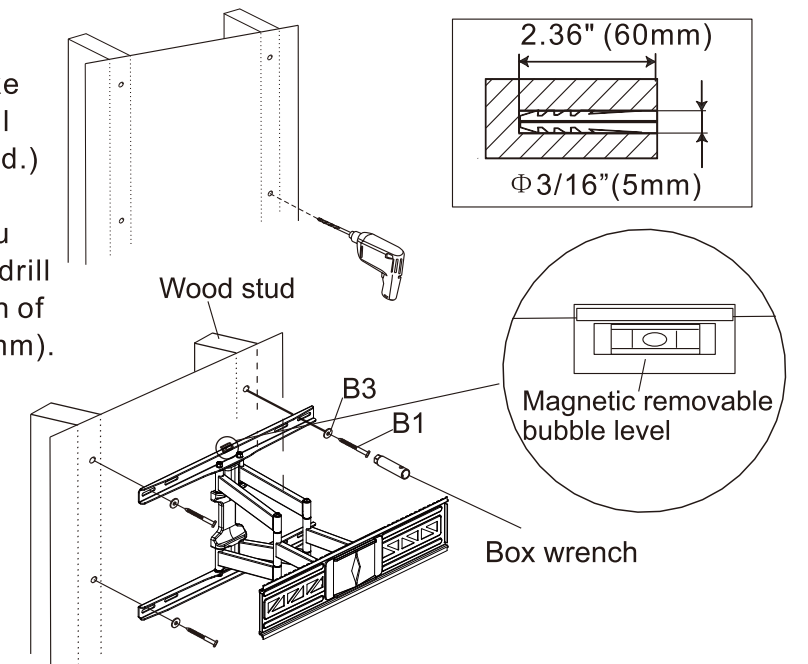

STEP 2: Alternative A - Attaching Brackets To Screen

Connect mounting Rails (2) to the back of your TV using four screws (A - I), depending on the size of the VESA holes on the back of your TV and washers (L).

Note: If the screws (A - I) are too long for the mounting holes or there is indentation in the back of your TV, you can use the extension washers (J or K) between the mounting Plates and Washer (L).

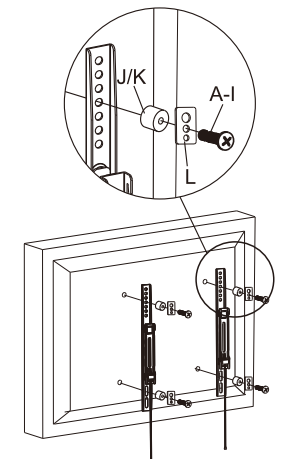
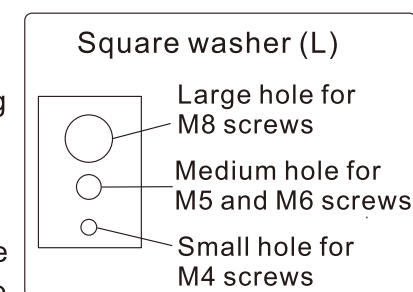

STEP 2: Alternative B - For TVs with a Curved Back or Obstruction

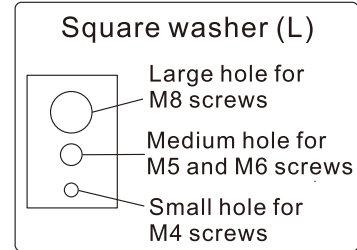
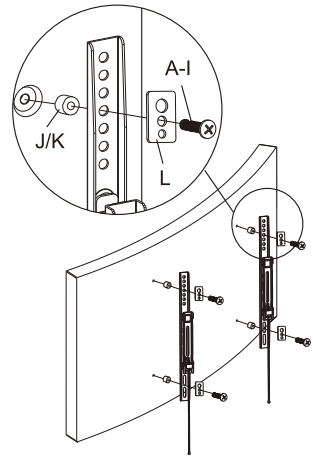

Connect mounting Rails (2) to the back of your TV using four screws (A - I), depending on the size of the VESA holes on the back of your TV and washers (L).

Note: If the screws (A - I) are too long for the mounting holes or there is indentation in the back of your TV, you can use the extension washers (J or K) between the mounting plates and the TV.

STEP 3: Placing the Plastic Cover on the Wall Plate

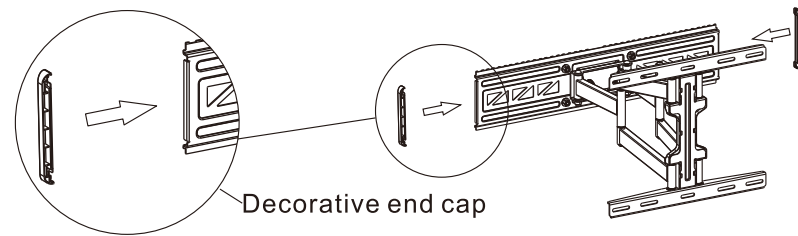

STEP 4: Hang the TV onto the Wall Plate

- Slide mounting Rails (2) onto the mount plate (1).
- Clip the two arms into the gear to secure the TV on the mount. Stick the magnetic pendants on the brackets.

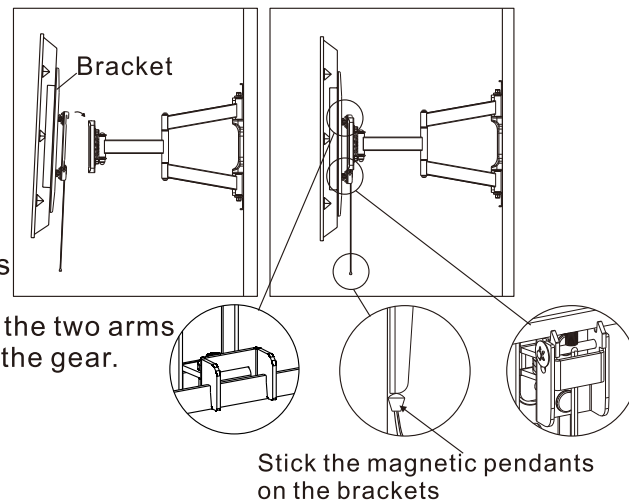

STEP 5: Adjust Tilting Function

Tighten or loose the screw nuts M8 on the head of the TV plate to adjust the tilting function

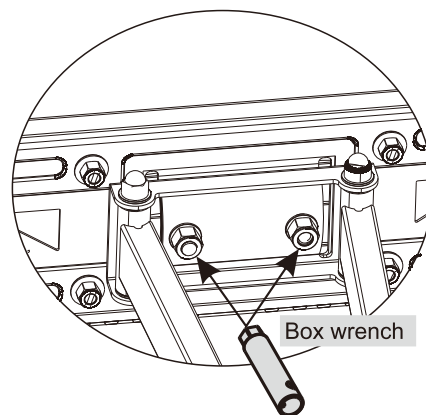

STEP 6: Cable Management

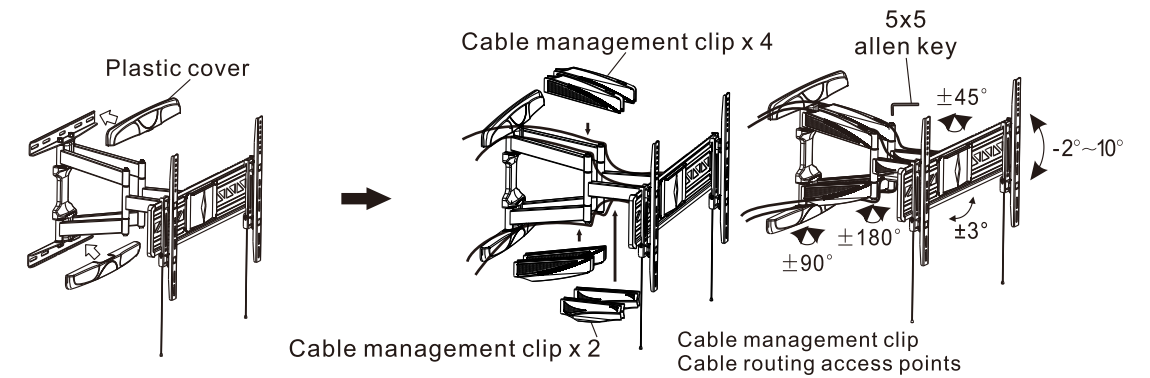

- Placing the plastic cover to the wall plate.
- Clip the cable management cover to the mount, and manage the cable neatly.

Note: How to use the Safety Lock

1. Assembling

Press the brackets after you put them on the wall plate, then they would be locked with wall plate.

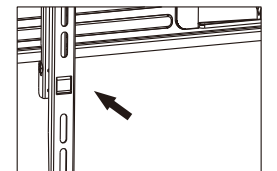

2. Disassembling

Pull down two strings together to unlock the brackets from the wall plate, then you can take brackets down.

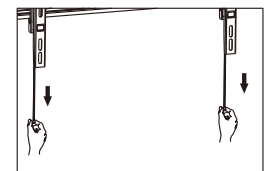

CAUTION

This product contains small items that could be a choking hazard if swallowed. Keep these items away from young children.

- Make sure these instructions are read and completely understood before attempting installation. If you are unsure of any part of this installation, please contact a professional installer for assistance.
- The wall or mounting surface must be capable of supporting the combined weight of the mount and the display, otherwise the structure must be reinforced.
- Safety gear and proper tools must be used. A minimum of two people are required for this installation.
- Please check joint parts every two months to ensure that no screws have loosened.

This product was designed to be installed on wood stud walls and solid concrete walls. Before installing, make sure the wall will support the combined load of the equipment and hardware. Never exceed the maximum load capacity 99 lbs (45 kg), or else it may result in product failure or personal injury.

Note: This product is intended for indoor use only. Use of this product outdoors could lead to product failure or personal injury.

ZOXOU INC. (Distributor)

ADDRESS: 47618 Kato Road, Fremont, CA, 94538 United States
 TEL: 1-855-421-2808
 Facebook: Loctek
 Twitter: LoctekOfficial
 Web: www.loctek.us

LOCTEK VISUAL TECHNOLOGY CORP (Manufacturer)

ADDRESS: No. 588 Qihang South Road, Binhai Industrial Zone, Yinzhou District, Ningbo China
 WEB: www.loctek.com

