

Adjustable Height A/V Carts

Available in 5 Colors:



AVJ42C

Features:

- Roll formed shelves with powder coat paint finish
- Cable pass through holes in top and middle shelf
- 4" ball bearing casters, two with locking brake
- 1/4" retaining lip around each shelf
- Cabinet models have locking doors with full length piano hinges
- No slip rubber mat for top shelf
- 3-Outlet, surge suppressing electric assembly With 15' Cord, UL and CSA listed

Color Options:

| | | | | |
|--------------|-------------------|------------------|-----------------------|-------------------|
| Black | Gray LG | Red RD | Burgundy BY | Blue RB |
|--------------|-------------------|------------------|-----------------------|-------------------|

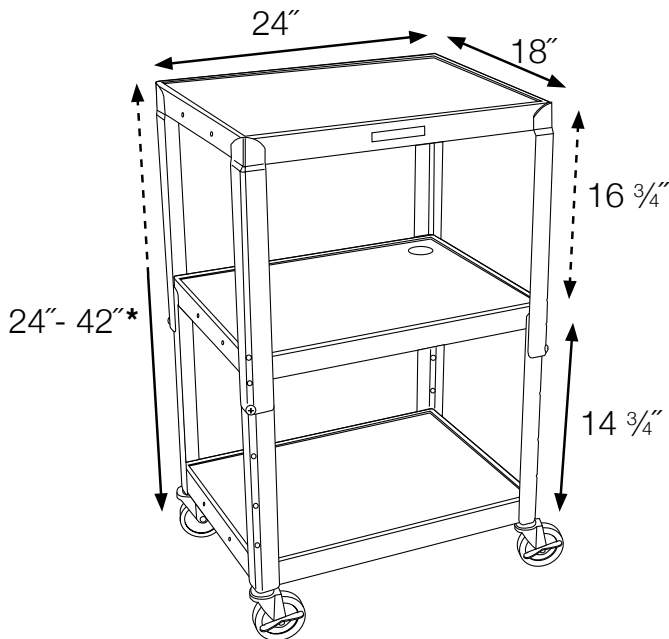

* - in 2" increments



AVJ42

Available in 11 Colors:



| | | | | | |
|----------------|---------------------|---------------------|--------------------|-----------------------|--------------------|
| Color Options: | Black | Gray LG | Red RD | Burgundy BY | Blue RB |
| | Yellow YW | Nickel CH | Putty OW | Green GN | Purple P |
| | | | | | Navy Z |

To specify which unit color is ordered, replace ★ in this example product number with available color option of choice:
AVJ42-★