

# LLTP32-B - 32-UNIT CART WITH TIMER

### Product Specifications:

Item Number	LLTP32-B	
Material	Powder Coated Steel	
Color Finish	Black	
Capacity	32 units	
Cart Dimensions	28.5"W x 21"D x 38.25"H (w/handle) 28.5"W x 21"D x 38.25"H (w/out handle)	
Weight	107 lbs.	
Shelf Quantity	3	
Shelf Dimensions	Top 2 Shelves: 28"W x 16"D x 11.5"H Bottom Shelf: 28"W x 16"D x 4"H	
Divider Make	Rubber Coated Steel	
Divider Distance	1.5"	
Doors	2 front; 2 back	
Ventilation	All sides	
Power	Two 16-outlet vertical power strips; UL Approved	
Voltage	110V	
Cable Management	Charging Cord Clips	
Lock	Key-lock on front door and back door; Includes 2 keys	
Casters (4)	4" rubber non-skid; two casters include locking brakes	
Meets ANSI/BIFMA	Yes	
Timer	ETL listed	
Ship Method	Freight	
Shipping Carton Dims	1 Carton; 31"W x 23"D x 36"H	
Shipping Weight	111 lbs.	
Assembly Required	Minimal; attach handle bar and casters	

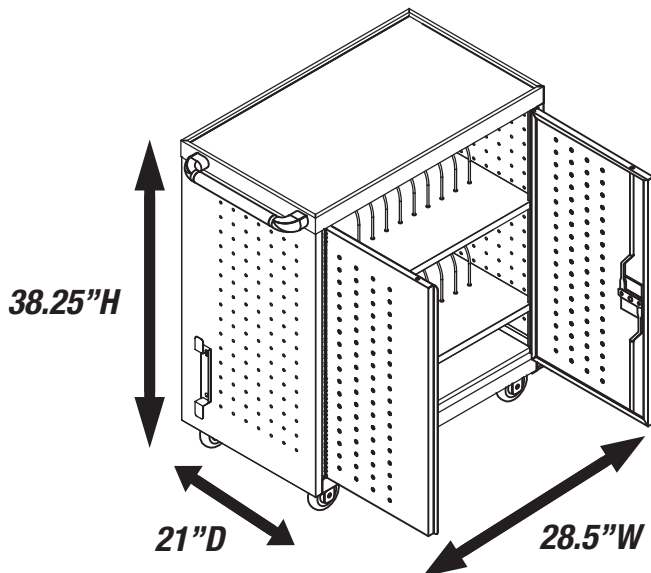

To Order, Call Your  
 Sales Representative  
 or 800-323-4656