

# LOTM16 - 16 UNIT OPEN TABLET/CHROMEBOOK CHARGING CART

**Product Specifications:**

Item Number	LOTM16
Material	Steel
Color Finish	Gray & White
Capacity	16 Tablets / Chromebooks
Cart Dimensions	27" W x 14.75" D x 30" H
Weight	37 lbs.
Shelf Quantity	1
Divider Make	Plastic (High Impact Polystyrene)
Divider Distance	1.35"
Divider Slot Dimensions	1.35" W x 8" D x 10.43" H
Electrical Tray Dimensions:	Bottom of Tray: 6.8" D x 24.4" W Top of Tray (opening): 6.1" D x 24.4" W Height of Tray: 3.25" H
Cord Length	6'
Cable Management	Two cord clips per divider
Casters (4)	1.6" casters; two with locking brakes
Weight Capacity	75 lbs.
Power	16-outlet horizontal power strip; UL Approved
Voltage	125V / 15A
Ship Method	Ground
Shipping Carton Dims	One carton; 33" W x 18" D x 5.25" H
Shipping Weight	41 lbs.
Assembly Required	Yes



205 Westwood Ave, Long Branch, NJ 07740  
 Phone: 866-94 BOARDS (26273) / (732)-222-1511  
 Fax: (732)-222-7088 | E-mail: sales@touchboards.com

Top View

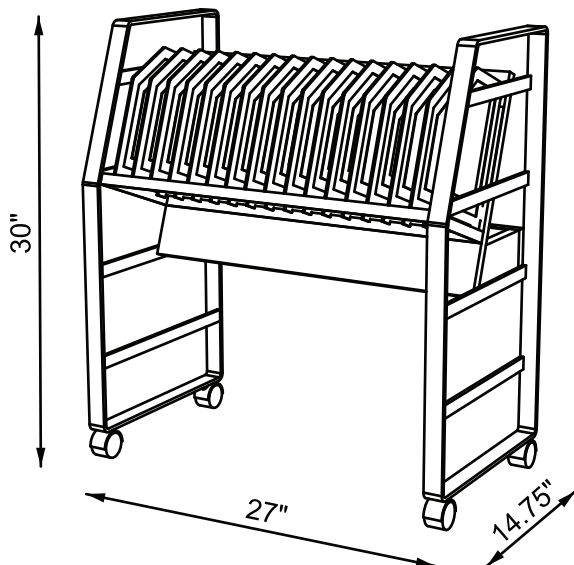
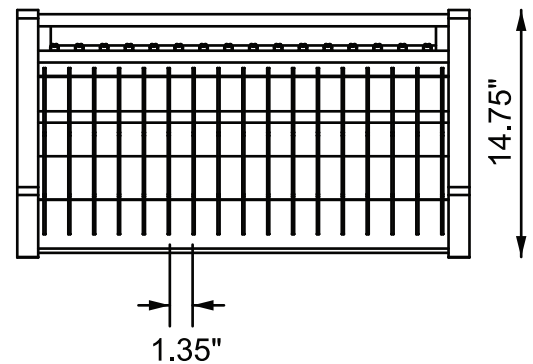

27"

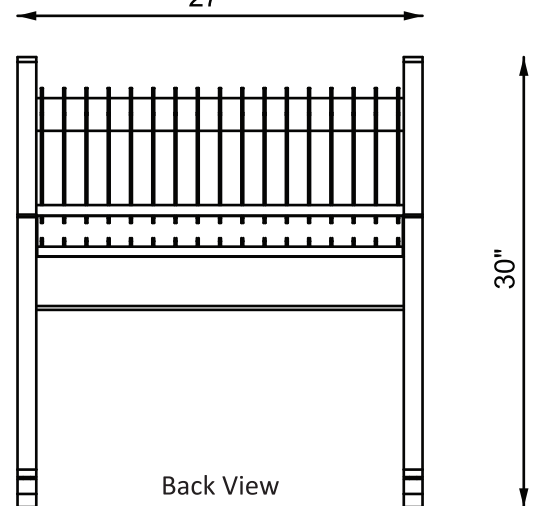

Back View

2245 Delany Road, Waukegan, IL 60087  
 800-323-4656 | Fax 847-244-1818 | www.LuxorFurn.com



INNOVATIVE WORKSPACE PRODUCT SOLUTIONS