

# Touchboards

205 Westwood Ave, Long Branch, NJ 07740  
Phone: 866-94 BOARDS (26273) / (732)-222-1511  
Fax: (732)-222-7088 | E-mail: sales@touchboards.com

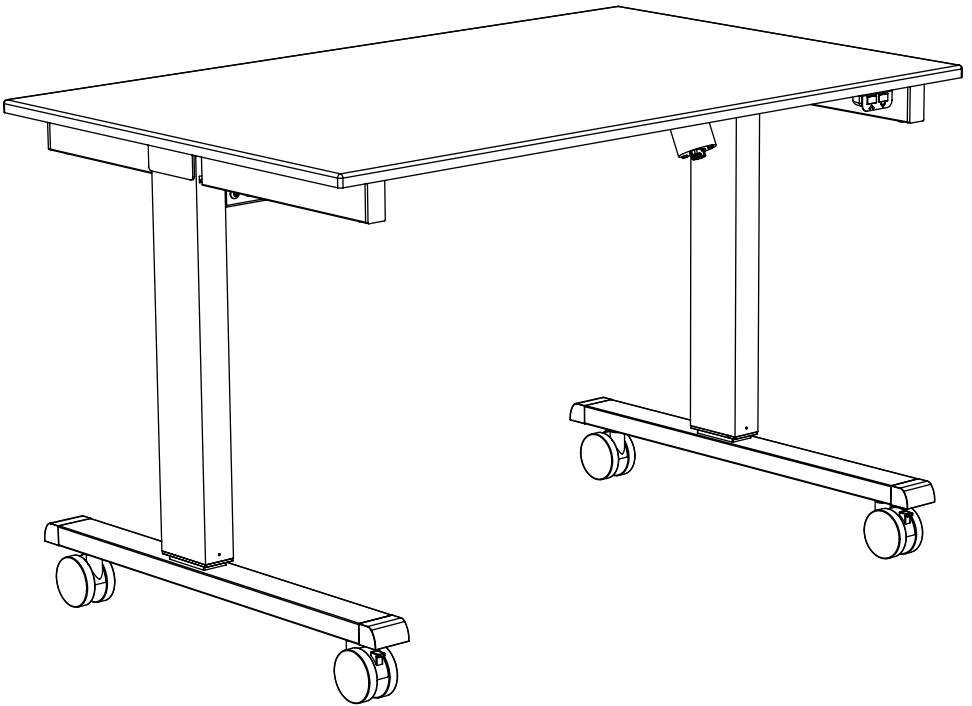

## Electrical Operated Stand Up Desk Assembly Guide for 60" & 48" Wide Flat Top Desks

# Table of Contents

Table of Contents . . . . .	3
Warnings & Guidelines . . . . .	4
Parts List & Hardware . . . . .	5
<b><u>Assembly and Installation</u></b>	
Assemble the right and left frame . . . . .	6
Assemble the cross bars . . . . .	7
Attach electric adjustment housing . . . . .	8
Flip desk upright and install optional electric . . . . .	9
Install rotating cross bar . . . . .	10
Mount power supply to unit . . . . .	11
Plug in electrical cords to power supply . . . . .	12
Attach the desk surface . . . . .	13
Attach remaining bolts to the desk surface . . . . .	14
Mount electrical controller and cable clips . . . . .	15

## **Tools Recommended**

- Phillips Screwdriver

## **ATTENTION!**

Do not fully tighten screws until completely assembled

## **WE ARE GIVING YOU A STANDING OVATION**

You did it! You took the first step towards healthier living by purchasing our stand up desk. We couldn't be happier to have you joining the millions of people who were tired of sitting around and ready to take a stand for a healthier life.

This desk was built with you in mind and every detail was carefully crafted. The following assembly guide is best accomplished with two people. If you have any questions or concerns contact your local dealer

# IMPORTANT SAFETY INSTRUCTIONS

## Read all instructions before using the product.

Every person who is responsible for this table at installation or employment of the table in daily use or in service and repair work should carefully read these instructions. Keep these instructions close to your sit/stand table.

### DANGER

To reduce the risk of electric shock: Always unplug this furnishing from the electrical outlet before cleaning.

### WARNING

To reduce the risk of burns, fire, electric shock, or injury to persons:

1. Unplug from outlet before putting on or taking off parts.
2. Use this furnishing only for its intended use as described in these instructions. **DO NOT** use attachments not recommended by the manufacturer.
3. **DO NOT** operate this furnishing if it has a damaged cord or plug, if it is not working properly, if it has been dropped or damaged, or dropped into water. Return the furnishing to a service center for examination and repair.
4. Keep the cord away from heated surfaces.
5. **DO NOT** use outdoors.
6. **DO NOT** operate where aerosol (spray) products are being used or where oxygen is being administered.

7. **DO NOT** overload the table - maximum load is 70kg / 154 lbs.
8. Close supervision is necessary when this furnishing is used by, or near children, invalids, or disabled persons.

This appliance shall only be used together with the included power supply unit. If you are having trouble with your power supply or your power supply is not operating correctly, **DO NOT** disassemble contact your local dealer.

### Usage of the Table

- The table shall only be used as a working table with the possibility to continuously adjust working height between sitting and standing position. The table shall only be used indoors and in dry premises (office environment or similar).
- The table must not be overloaded - maximum load is 70 kg / 154 lbs. The motors may be run continuously for a maximum of one (1) minute. Afterward, the motors must stand by for approximately nine (9) minutes before they can be used again.
- The motors stop automatically when the table reaches its lowest or highest position respectively.
- If the unit has been unplugged or a power outage occurs a system reset will need to be performed. To reset the system simply hold the right (lowering) button until the desk reaches it's lowest position then wait for (5) seconds for the gears to reset.
- **ATTENTION!** The electrical cable must have full mobility. Place the cables so that they **DO NOT** get tangled or damaged.

### **Adjusting Table Height:**

1. Make sure no objects will obstruct the table when adjusting table height.
2. In order to run the table up/down, press the controller buttons with an arrows pointing up and down respectively.
3. Unplug the hand controller when not in use to prevent unauthorized use.

### **Safety Regulations:**

- When the table is run up/down, keep a safe distance to avoid the risk of being squeezed between the moving table top and fixed objects in the surrounding area.
- When the table is run up/down the user shall keep watch so that nobody is injured or no object is damaged. The table top must not bump into a fixed object so that the table is overturned. Always remove any office chair before the table is run up/down.
- When the table is left unattended, the hand control plug must be unplugged and placed out of reach of children.
- The table tripod must not be altered or reconstructed in any way. In service and repair work of the table, the electrical cable must always be disconnected from the wall socket.
- Alterations to the control box are absolutely forbidden!
- The table must not be used as a hoisting device for persons.

### **Maintenance and Repair:**

- After approximately one (1) week of use, check that the screws are properly tightened.

- If the table cannot be lowered or raised, check the connections between the legs and the wall socket and be sure the plugs are inserted fully into the power supply.
- If any part of the electrical system should need to be replaced, disconnect the electrical cable from the wall socket before replacing the electrical part to avoid risk of injury. After the electrical part has been replaced, connect the electrical cable back to the wall socket. The table is now ready for use.
- If the table still does not work please contact your local dealer.

### **SAVE THESE INSTRUCTIONS**

This device complies with part 15 of the FCC Rules. Operation is subject to the following two conditions:

1. This device may not cause harmful interference, and
2. This device must accept any interference received, including interference that may cause undesired operation.

### **WARNING**

Changes or modifications not expressly approved by the party responsible for compliance could void the user's authority to operate the equipment.



The crossed-out wheeled bin symbol indicates that the item should be disposed of separately from household waste. The item should be handed in for recycling in accordance with local environmental regulations for waste disposal. For more information please contact your dealer.

## Parts List

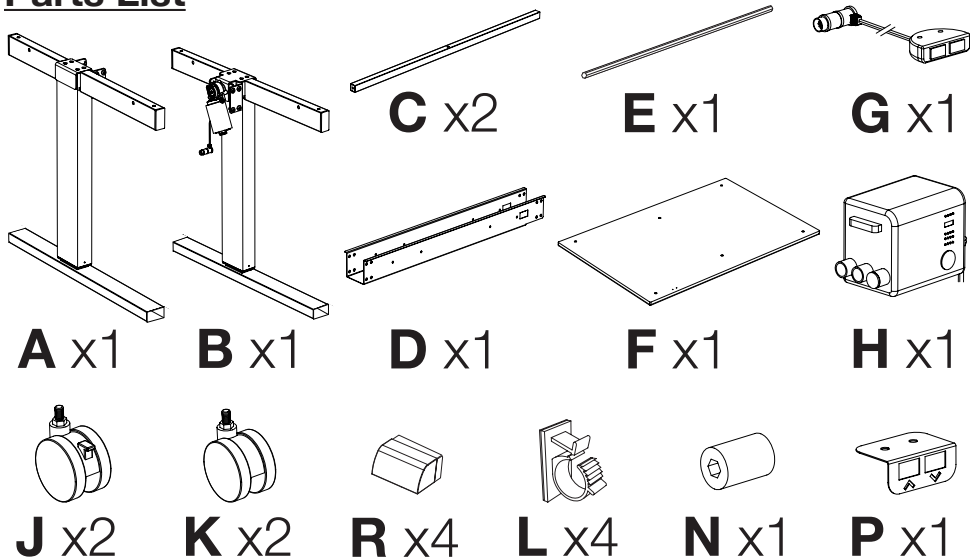

## Hardware (Actual Size)

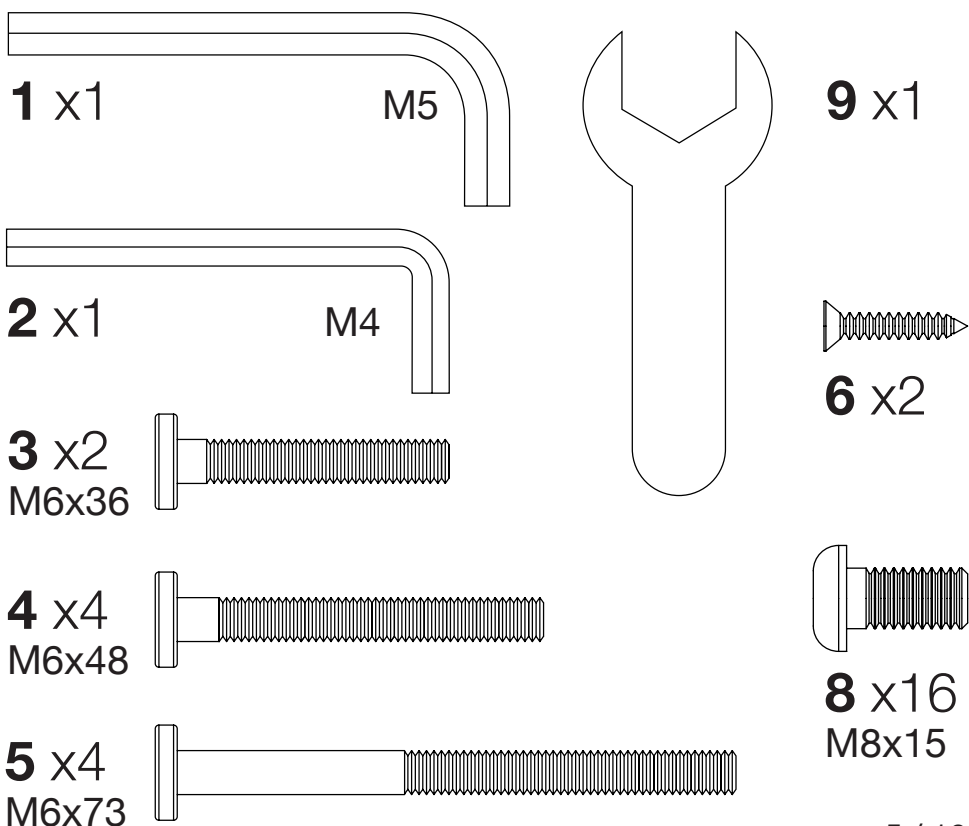

# 1 Assemble the right and left frame

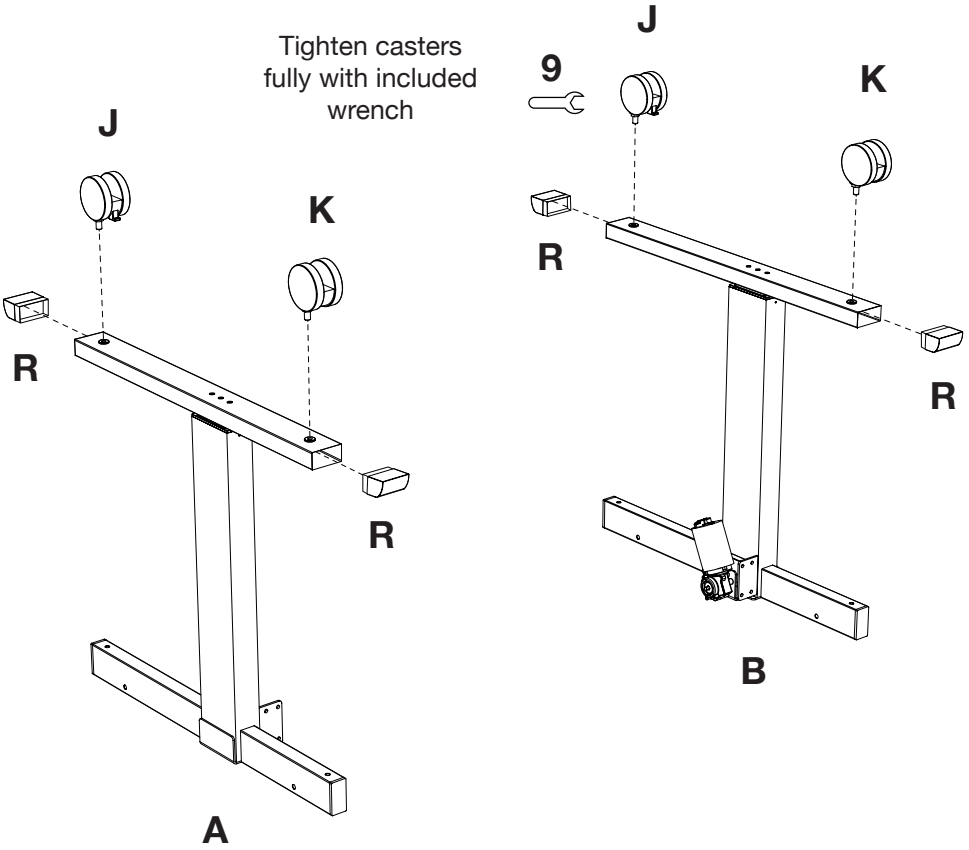

**Gather Parts:**  
A, B, J, K, R, 9

## 2 Assemble the cross bars

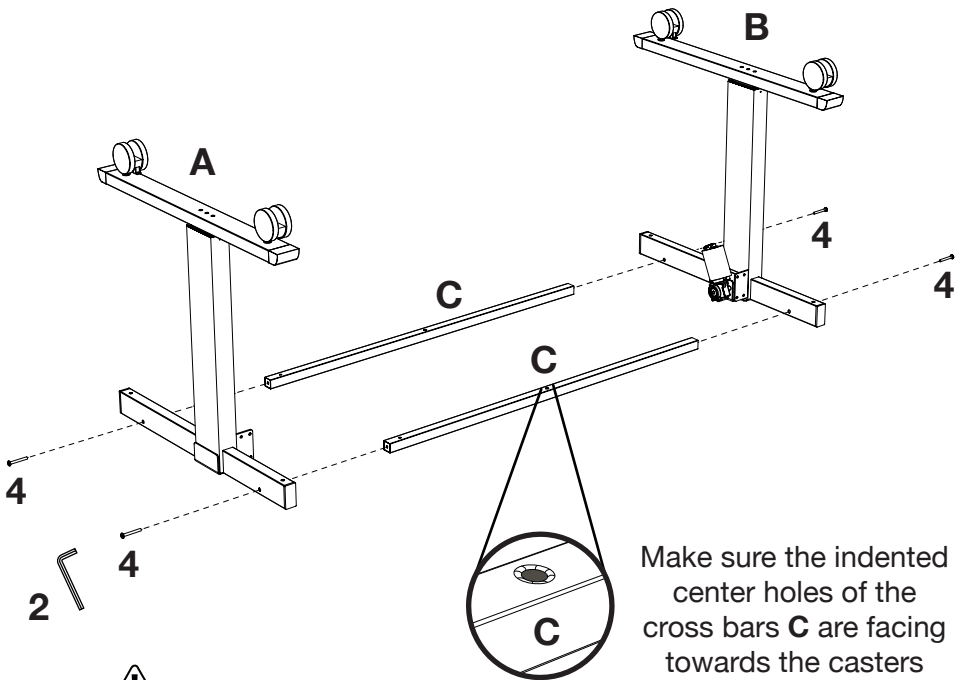

Assistance  
Recommended

Gather Parts:  
C, 2

&

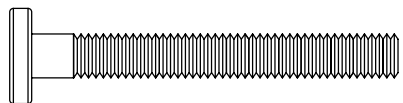

4 x 4  
M6x48

### 3 Attach electric adjustment housing

1

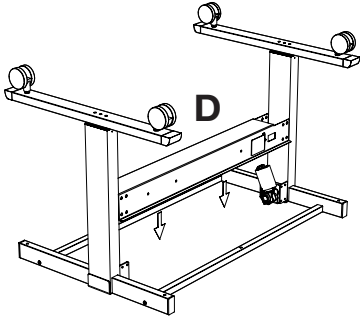

2

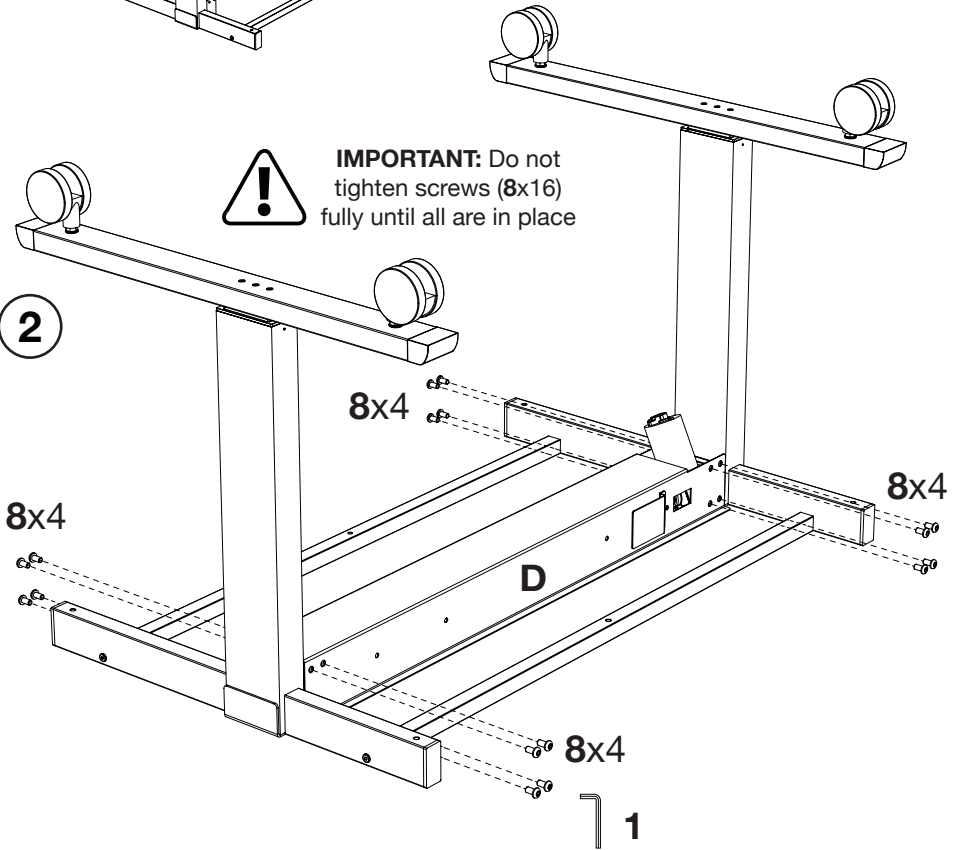

Gather Parts:  
D, 1

&

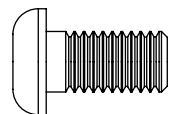

8 x16  
M8x15



## 4 Flip desk upright and install optional electric

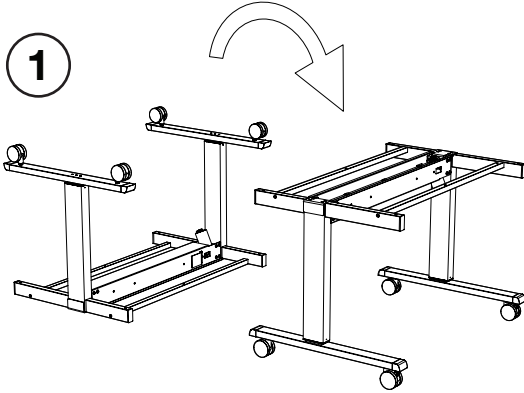

Heavy Lifting:  
Assistance  
Required

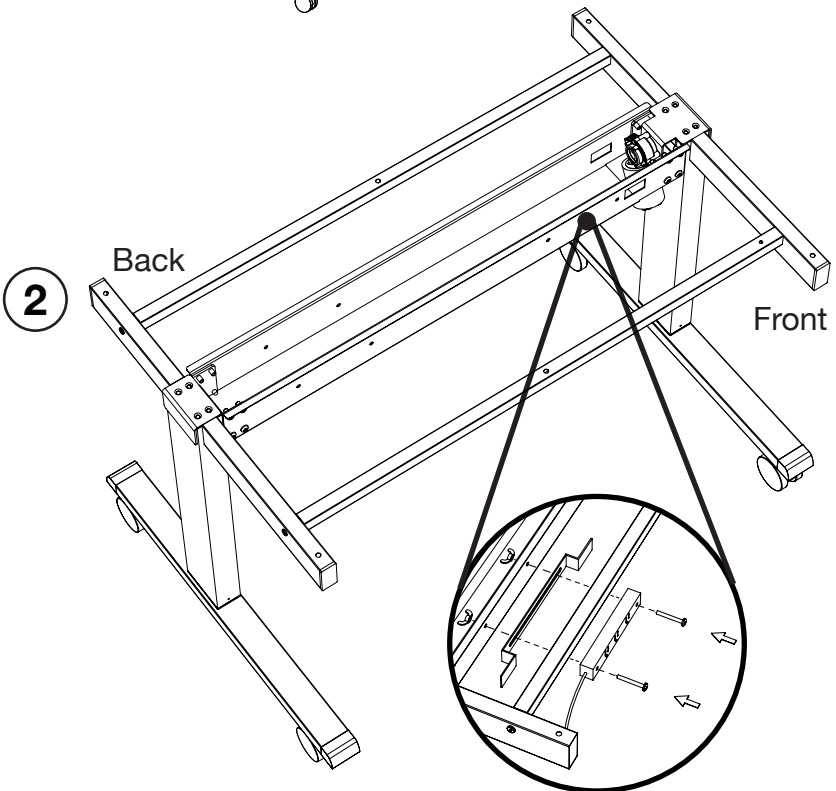

**IMPORTANT:** Install the **OPTIONAL** electric (**SOLD SEPARATELY**) before attaching the desk top to the frame.

## 5 Install rotating cross bar

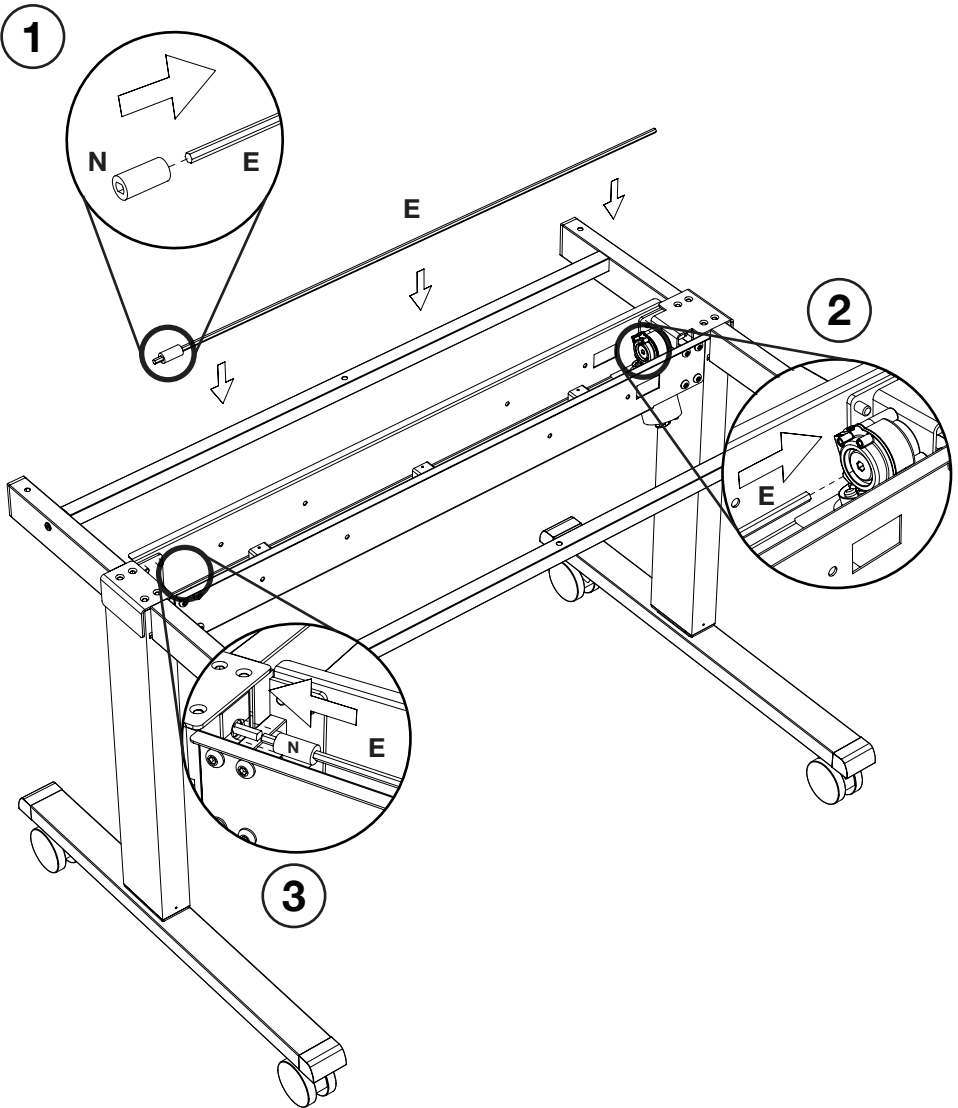

Gather Parts:  
N, E

# Touchboards

205 Westwood Ave, Long Branch, NJ 07740  
Phone: 866-94 BOARDS (26273) / (732)-222-1511  
Fax: (732)-222-7088 | E-mail: [sales@touchboards.com](mailto:sales@touchboards.com)

## 6 Mount power supply to unit

1

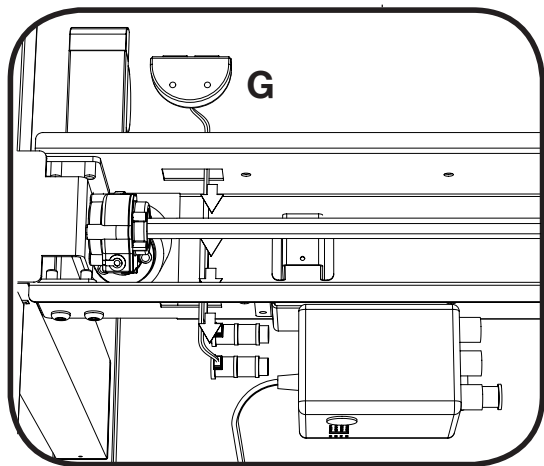
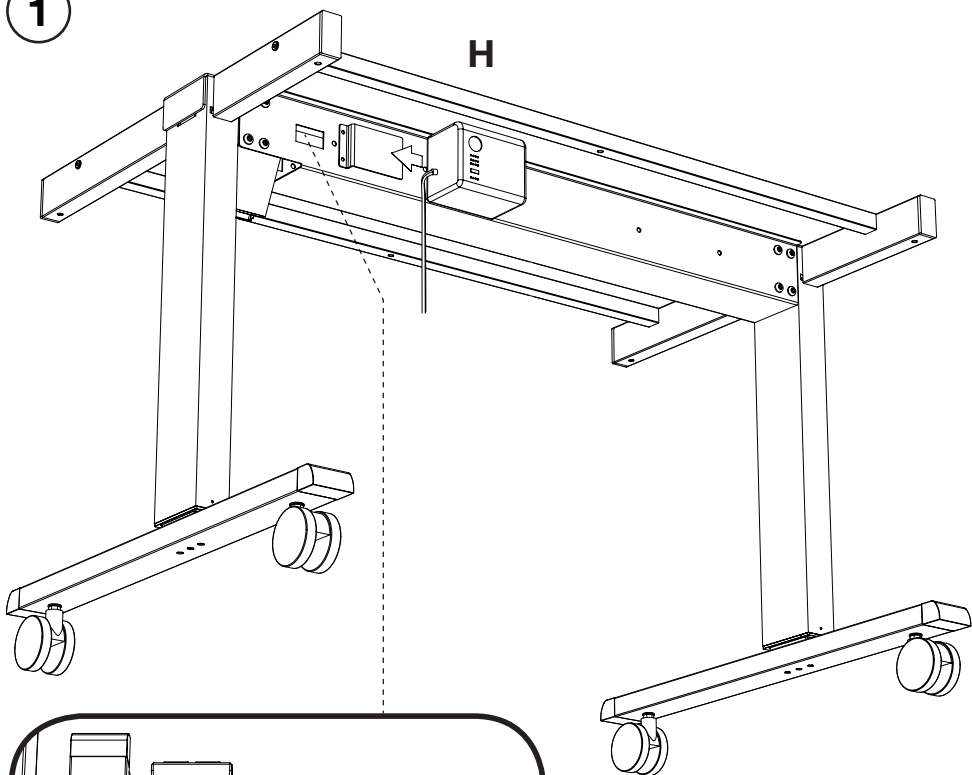

2

Feed the cords through the cable management holes.

Make sure to tuck any excess cables away from the motor to avoid tangles.

**Gather Parts:**

G, H

## 7 Plug in electrical cords to power supply

1

Attach the cable that is connected to the motor to the center plug. Make sure the pins line up correctly.

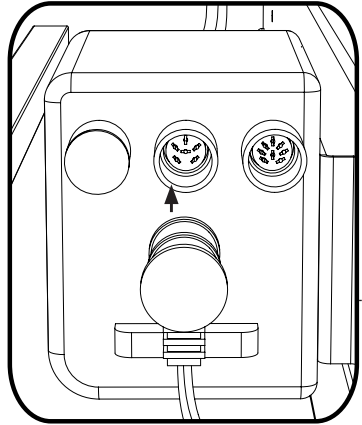
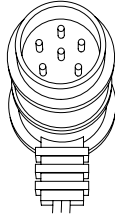

2

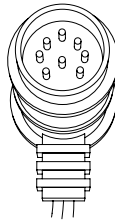
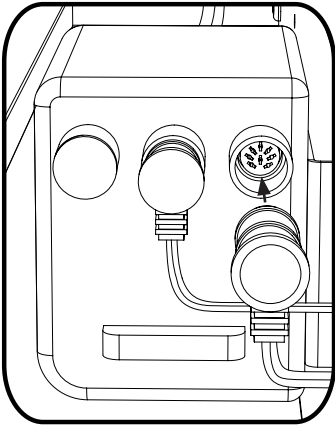

Attach the cable that is connected to the controller to the left plug. Make sure the pins line up correctly.

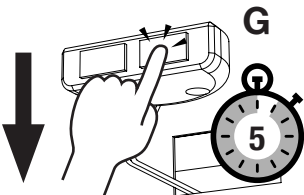

To set up the system, hold the right button until the unit is at its lowest position then wait for five (5) seconds. Also do this when a power outage occurs or if the unit has been unplugged.

# 8 Attach the desk surface

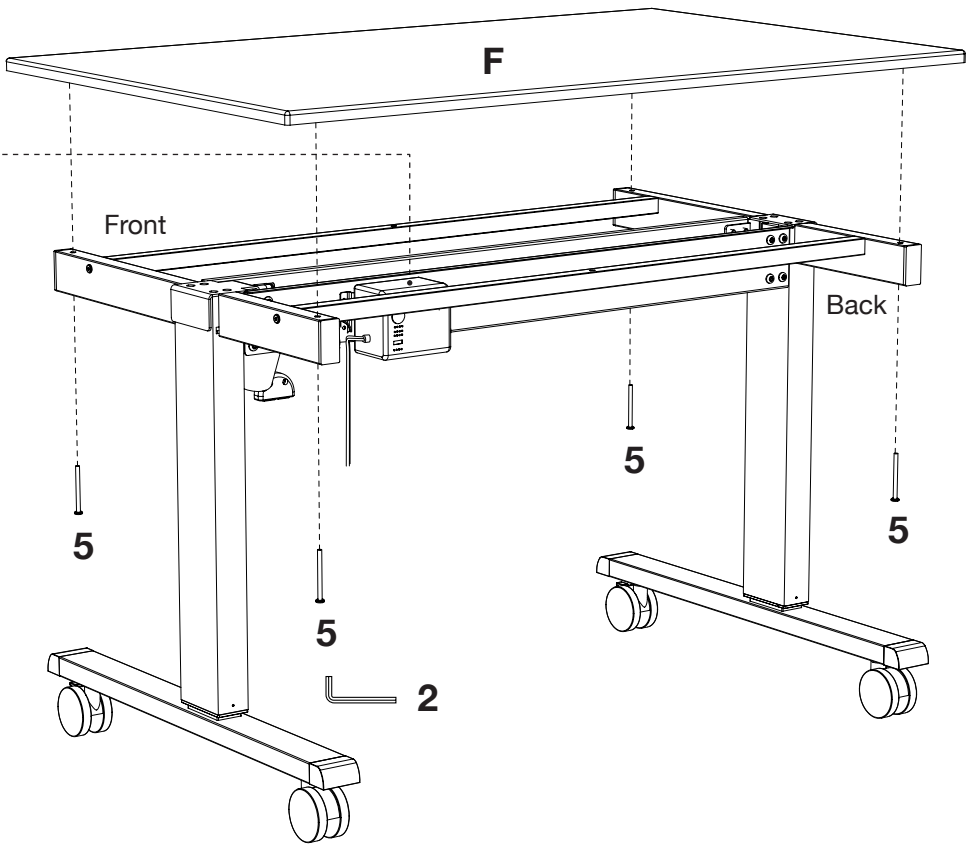

Gather Parts:  
F

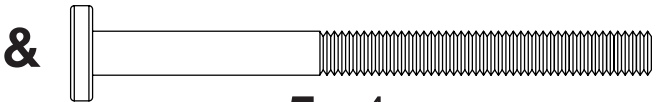

5 x 4  
M6x73

**9** Attach remaining bolts to the desk surface

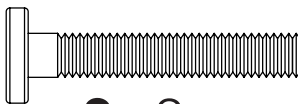
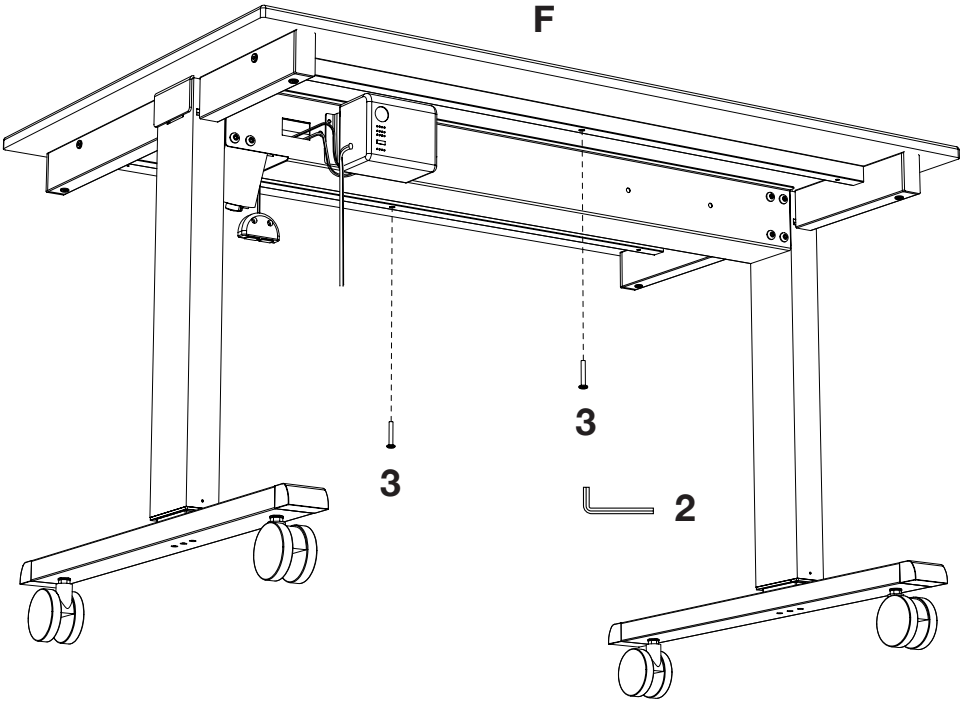

**3** x 2  
M6x36

# 10 Mount electrical controller and cable clips

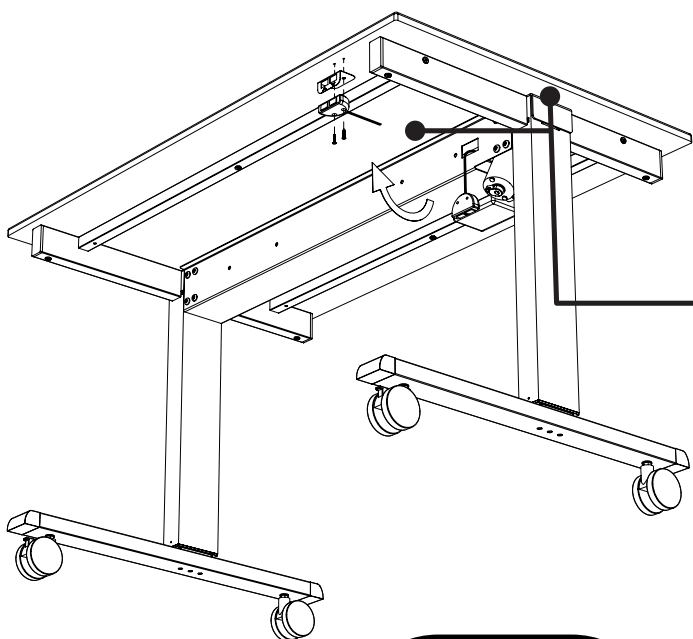

L x4

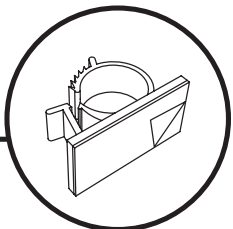

Attach cable management clips to desired position

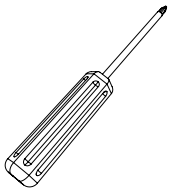

Phillips Screwdriver required for tightening screws 6

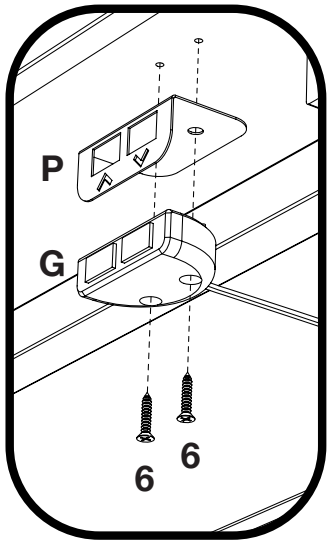

**MAKE SURE TO LEAVE PLENTY OF SLACK FOR CABLES TO MOVE FREELY DURING THE DESK ADJUSTMENT**

**Gather Parts:**  
P, G, L

&

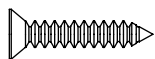

6 x2



**205 Westwood Ave, Long Branch, NJ 07740**

**Phone: 866-94 BOARDS (26273) / (732)-222-1511**

**Fax: (732)-222-7088 | E-mail: [sales@touchboards.com](mailto:sales@touchboards.com)**

**Questions or Feedback Call Us at:**

**800-323-4656**