

Parts List

Tools Included

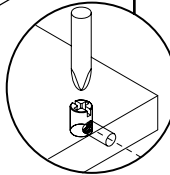

Alignment of the threaded insert may require a screwdriver.

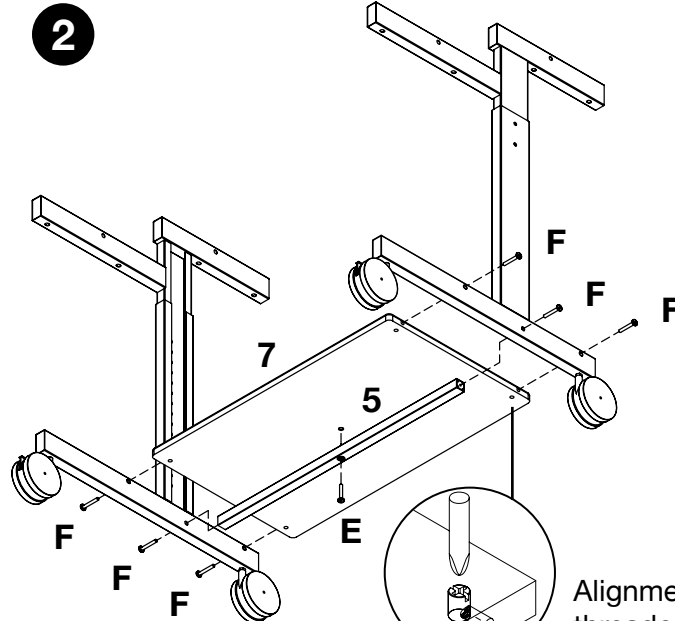
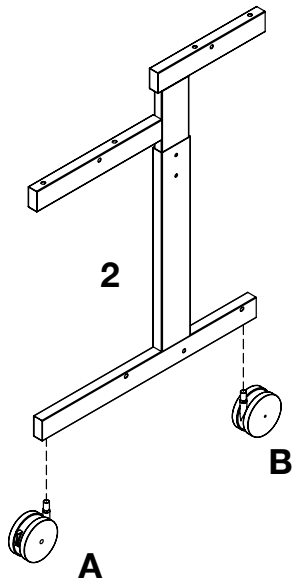
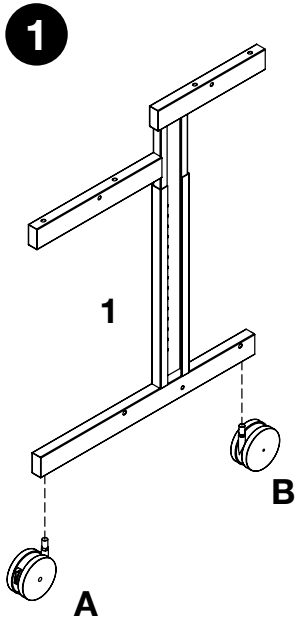
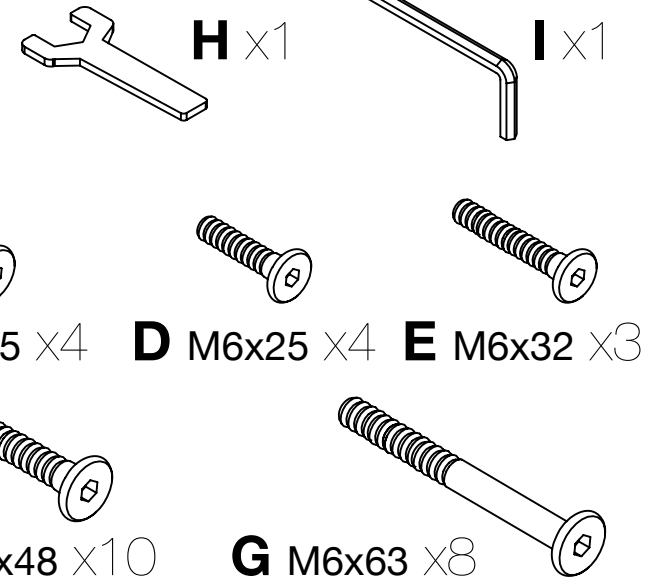
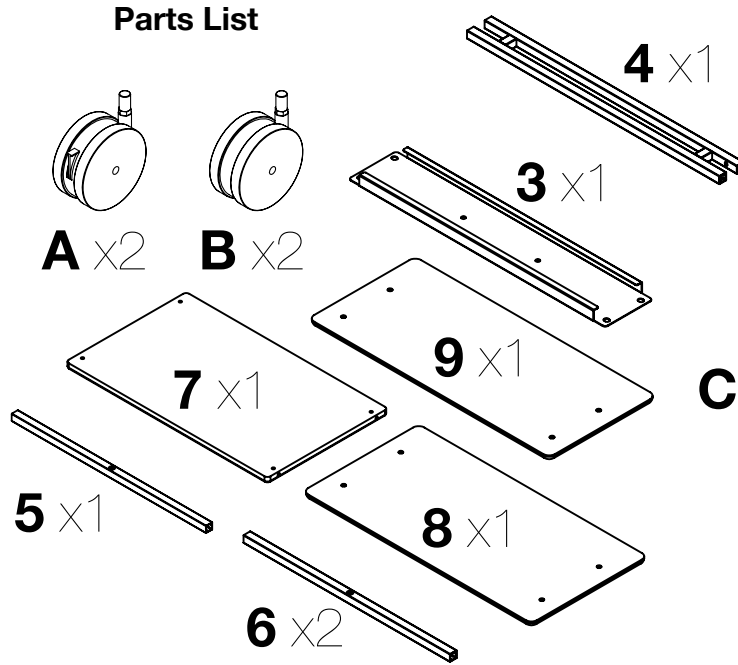
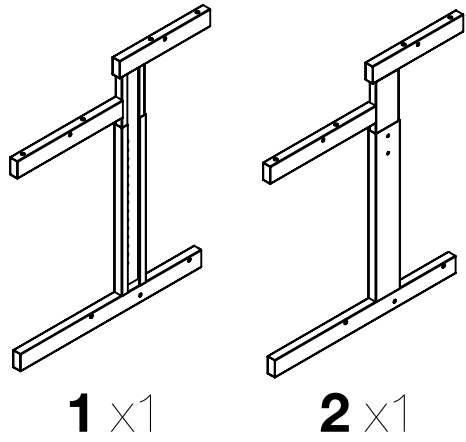
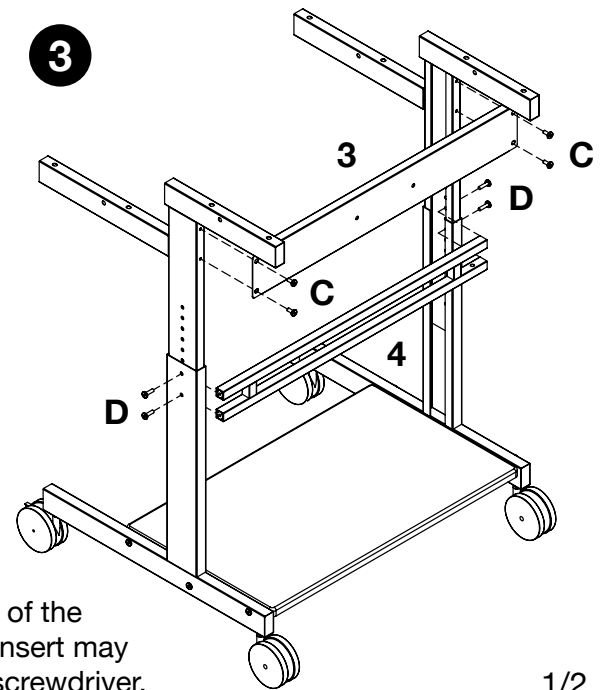

4

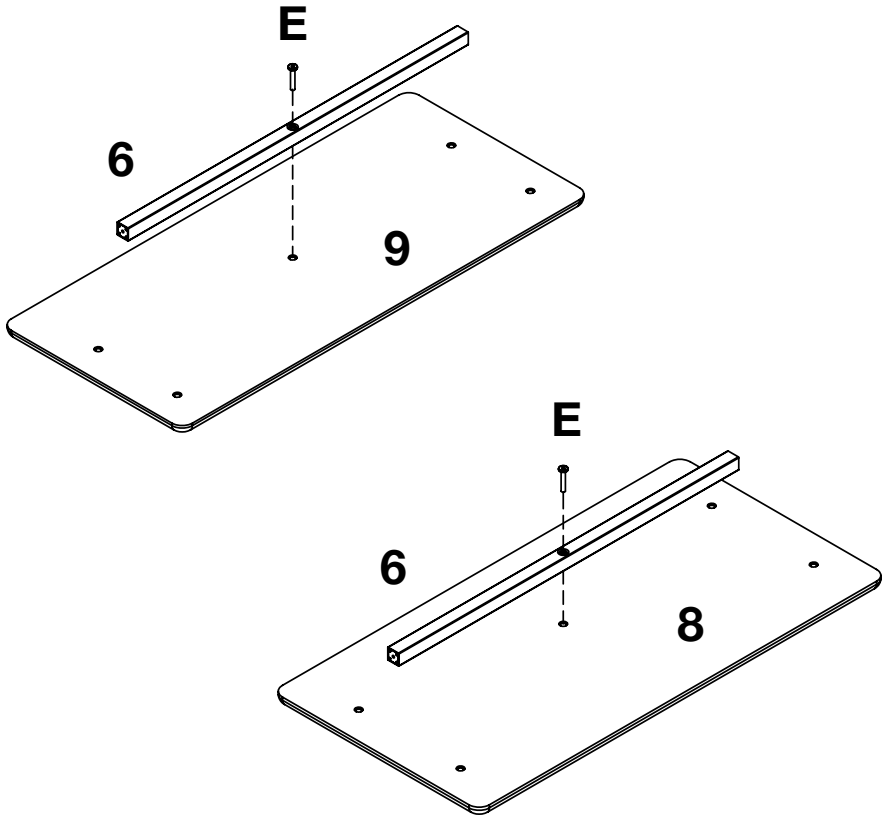

5

