

- Shelves are constructed with an injection molded thermoplastic resin that will not chip, warp, rust or peel
- Includes a 3-outlet UL listed electrical assembly with a 15 ft. cord
- Electrical assembly is recessed to insure easy passage through doorways and other tight spots
- Includes silent roll, 4" full swivel ball bearing casters, two with locking brakes
- Locking steel cabinet panels fit firmly into the specially fluted leg slots
- Includes a universal mount with 15 degrees (+ or -) of tilt
- E Series Includes a new extruded aluminum LCD Mount



**WPTV50E**

Holds up to a  
 46" LCD TV  
 VESA up to  
 800 x 600



**WPTV44CE**



**WPTV44E**



**WPTV28CE**



**WPTV28E**

#### WPTV44 Measurements:

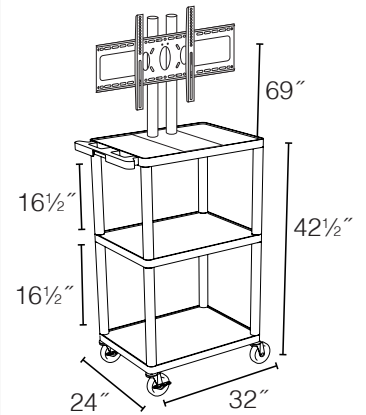

#### WPTV28 Measurements:

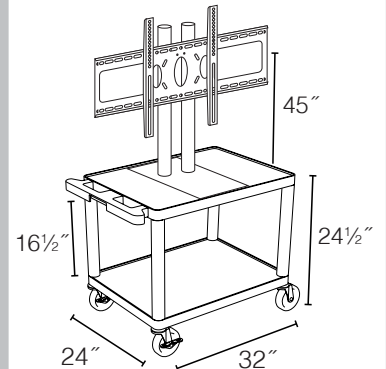

**\*Height is the measurement from the floor to mount center**