

LLTP32-B - 32-UNIT CART WITH TIMER

Product Specifications:

Item Number	LLTP32-B	
Material	Powder Coated Steel	
Color Finish	Black	
Capacity	32 units	
Cart Dimensions	28.5"W x 21"D x 38.25"H (w/handle) 28.5"W x 21"D x 38.25"H (w/out handle)	
Weight	107 lbs.	
Shelf Quantity	3	
Shelf Dimensions	Top 2 Shelves: 28"W x 16"D x 11.5"H Bottom Shelf: 28"W x 16"D x 4"H	
Divider Make	Rubber Coated Steel	
Divider Distance	1.5"	
Doors	2 front; 2 back	
Ventilation	All sides	
Power	Two 16-outlet vertical power strips; UL Approved	
Voltage	110V	
Cable Management	Charging Cord Clips	
Lock	Key-lock on front door and back door; Includes 2 keys	
Casters (4)	4" rubber non-skid; two casters include locking brakes	
Timer	ETL listed	
Ship Method	Freight	
Shipping Carton Dims	1 Carton; 31"W x 23"D x 36"H	
Shipping Weight	111 lbs.	
Assembly Required	Minimal; attach handle bar and casters	
Cord Length	10'	

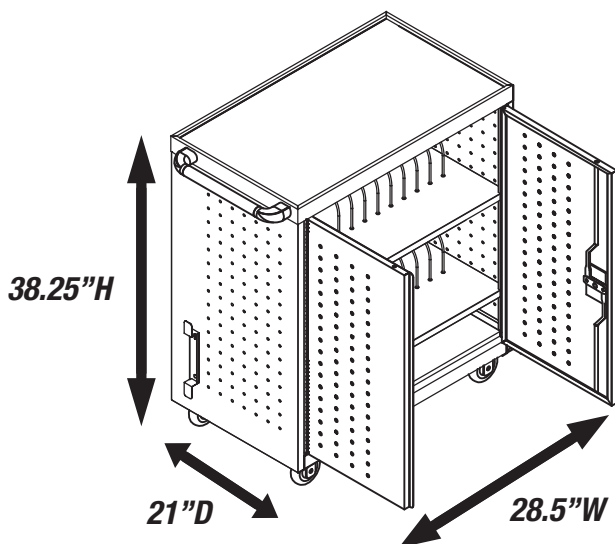

Special Note:

Due to the latest, larger size of the 20W Apple iPad and Samsung Chromebook USB-C charging block adapters, only half of the available plug outlets are accessible in this unit. If you are using these power adapters, please contact Luxor customer service for the availability of special adapter cords that can be used to regain access to all charging plugs.

To Order, Call Your Sales Representative or 800-323-4656

LUXOR

INNOVATIVE WORKSPACE PRODUCT SOLUTIONS