

Adjustable Height Metal Cart w/ Keyboard



- Steel shelves have a 1/4" retaining lip, with cable access holes
- No slip rubber mat for adjustable top shelf
- Pullout keyboard shelf which is ideal for chromebook & keyboards
- A set of silent roll, 4" full swivel ball bearing casters, two with locking brakes
- Includes a 3-outlet UL listed electrical assembly with a 15 ft. cord

AVJ42KB
W42AEKB



MADE IN USA

Available in 8 Colors:



Color Options:	Black	Gray -LG	Putty -OW	Red -RD	Blue -RB	Yellow -YW	Green -GN	Navy -Z
----------------	--------------	--------------------	---------------------	-------------------	--------------------	----------------------	---------------------	-------------------

Measurements:

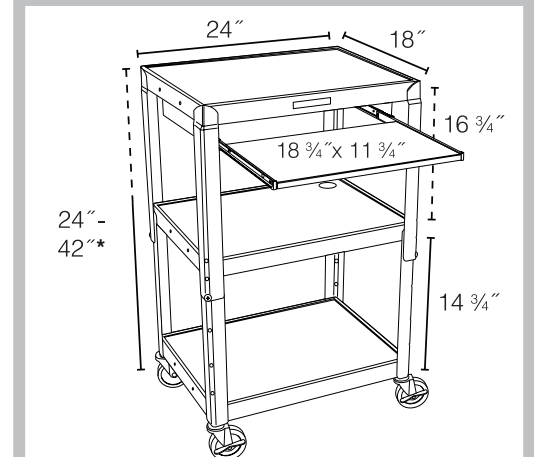

* - in 2" increments

Weight: 50 lbs.

To specify which unit color is ordered, replace ★ in this example product number with available color option of choice: **AVJ42KB★**