

## Structural Foam Plastic Cart

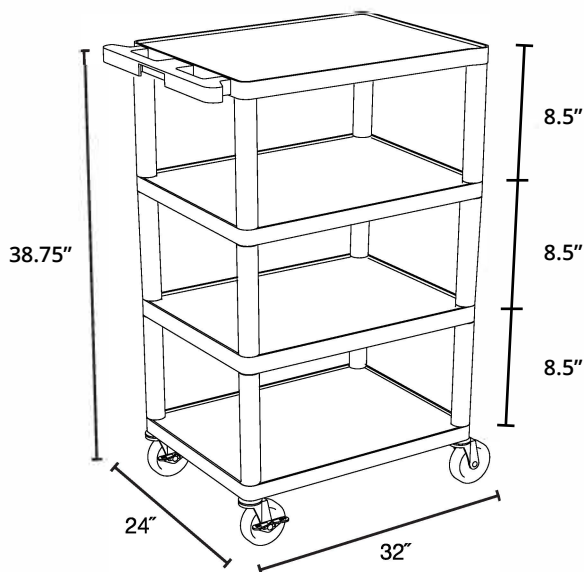

**BC40**  
32"W x 24"D x 38.75"H



### FEATURES

- Multipurpose utility cart
- Shelves and legs are constructed of an injection-molded thermoplastic resin that will not stain, scratch, dent or rust
- Four flat shelves with .25" retaining lip to secure items from sliding off
- Optional five or six shelf versions also available
- Ergonomic push handle molded into top shelf
- Rolling cart with four heavy-duty 4" casters, two with locking brake
- Maximum weight capacity: 300 lbs. (evenly distributed)
- Comes in black and gray
- Assembly required
- Made in the USA

### DIMENSIONS:

- Overall: 32"W x 24"D x 38.75"H
- Clearance between shelves: 8.5"