

LLTS32-B

32 CHROMEBOOK/LAPTOP/TABLET SMART CHARGING CART

Product Specifications:

Item Number	LLTS32-B
Material	Powder Coated Steel
Color Finish	Black
Capacity	32 Chromebooks, Laptops, or Tablets
Cart Dimensions (w/handle)	32.5"W x 23"D x 37"H
Cart Dimensions (w/o handle)	28.75"W x 23"D x 37"H
Weight	114 lbs.
Slot Size	1.3"W x 15.25"D
Divider Make	Plastic
Divider Distance	1.3"
Doors	2; Front & Back
Lock	Includes locking mechanism (padlock not included)
Ventilation	All sides
Cord Length	15'
Cord Quantity	1
Cable Management	AC Adaptor Bracket
Casters (4)	5" non-marring; two rigid and two swivel with locking brakes
Weight Capacity	130 lbs.
Power	Four 8-outlet horizontal power strips with built-in Smart Charging Controller Full certification to the UL60950-1 safety standard
Space Between Outlets	2.17"
Voltage	110-125V/12A ~ 220-240V/10A
Meets ANSI/BIFMA	Yes
Ship Method	Freight
Shipping Carton Dimensions	1 carton; 33"W x 27"D x 33"H
Shipping Weight	126 lbs.

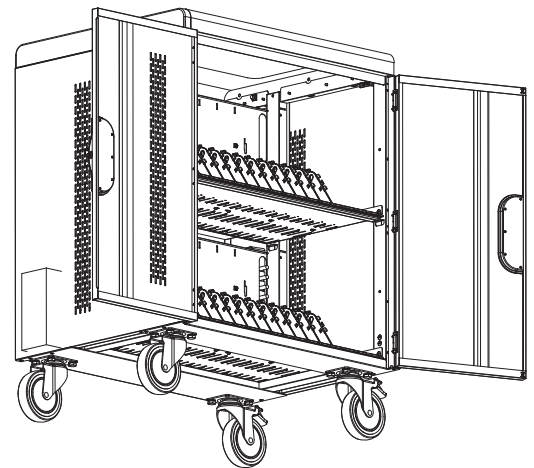
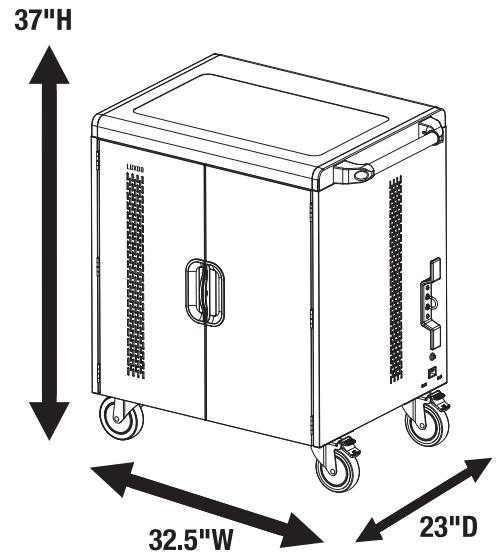

To Order, Call Your Sales Representative or 800-323-4656

2245 Delany Road, Waukegan, IL 60087
 800-323-4656 | Fax 847-244-1818 | www.LuxorFurn.com



INNOVATIVE WORKSPACE PRODUCT SOLUTIONS