

## MMGB6040M – SPEC SHEET

# MMGB6040 – DOUBLE-SIDED MOBILE MAGNETIC GLASS MARKER BOARDS

## Product Specifications

<b>Item Number</b>	MMGB6040
<b>Material</b>	Painted Glass
<b>Frame</b>	Aluminum; .75" edging
<b>Surface Type</b>	Magnetic Glass
<b>Full Dimensions</b>	63" W x 24" D x 72" H
<b>Board Dimensions</b>	58.5" W x 38.25" H
<b>Base Dimensions</b>	63" W x 24" D
<b>Tray Length</b>	35.5" W
<b>Casters (4)</b>	3" rollerblade-style; two casters include locking brakes
<b>Actual Weight</b>	94 lbs.
<b>Shipping Method</b>	Freight
<b>Shipping Carton Dims</b>	67"W x 58"D x 3"H
<b>Shipping Weight</b>	112 lbs.
<b>Assembly Required</b>	Yes

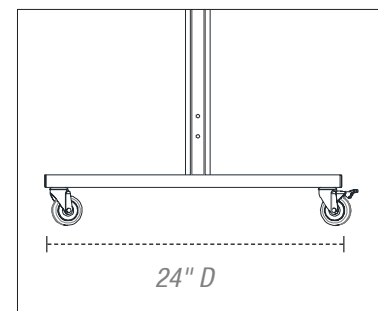
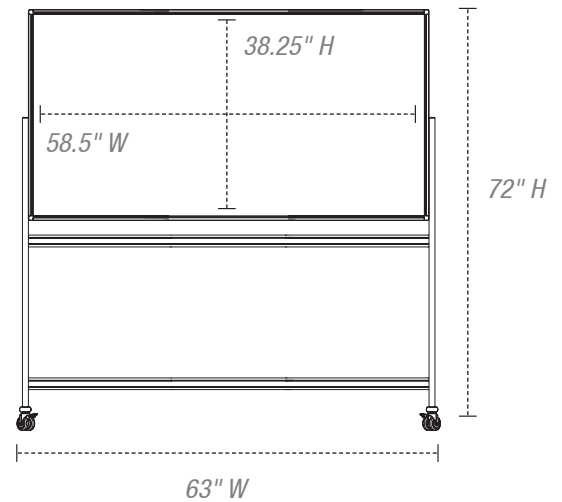

**To Order, Call Your  
Sales Representative  
or 800-323-4656**

2245 Delany Road, Waukegan, IL 60087  
800-323-4656 | Fax 847-244-1818 | [www.LuxorFurn.com](http://www.LuxorFurn.com)

# LUXOR

INNOVATIVE WORKSPACE PRODUCT SOLUTIONS