

MIPRO®

DPM-3 Digital Audio Recorder Module

User Guide



I. Part Names, Fig. 1, 2, 3

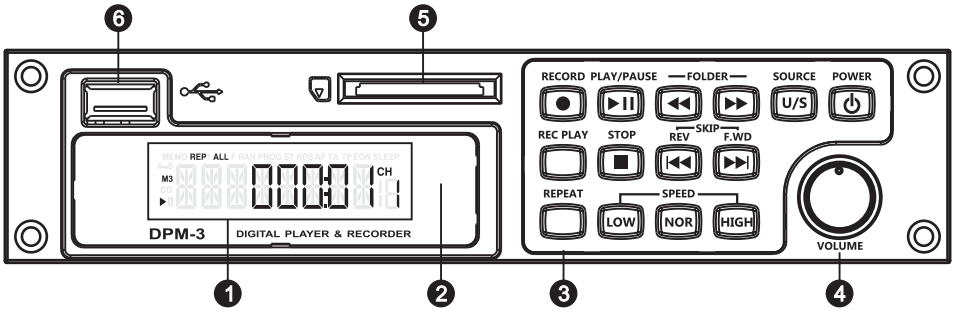

Fig. 1: Front Panel

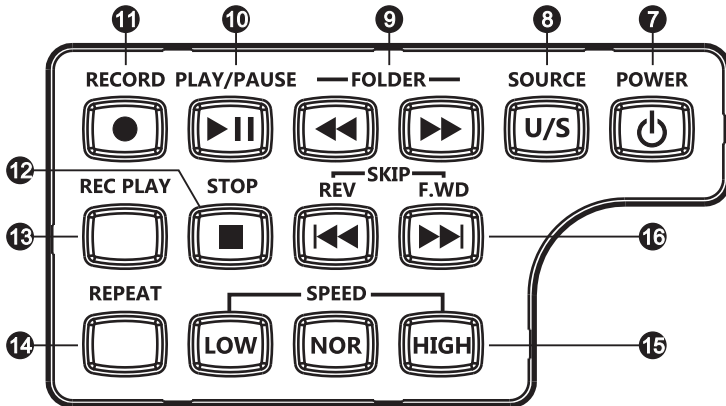

Fig. 2: Control Panel



Fig. 3: LCD Display Screen

- ❶ LCD Display Screen.
- ❷ Remote Control Port.
- ❸ Control Panel.
- ❹ Volume Knob.
- ❺ SD Card Slot.
- ❻ USB Port.
- ❼ POWER.
- ❽ SOURCE Mode button.
- ❾ FOLDER Selection button.
- ❿ PLAY/PAUSE.
- ⓫ RECORD.
- ⓬ STOP.
- ⓭ REC PLAY.
- ⓮ REPEAT.
- ⓯ SPEED.
- ⓰ SKIP: F.WD ►► Forward to the next track. REV ◄◄ Backward to the last track. Long press to fast forward / backward to the next / last tracks.

II. Operating Instructions

1. Media Slots, Fig. 4:

- (A) USB Disk: Insert USB 2.0 into the USB port for playing MP3 / WMA / FLAC / APE / WAV / M4A / AAC / OGG files.
- (B) SD Card Reader: Insert a SDHC card with gold contacts facing up and label facing down. Press it again to pop out.
- (C) Format USB and SD card before playback. Format standard is FAT.
- (D) Press SOURCE Mode button **8** to select USB or SD card. USB plays first prior to SD card.
- (E) NO DISK displays when it is unable to detect or read a media source.

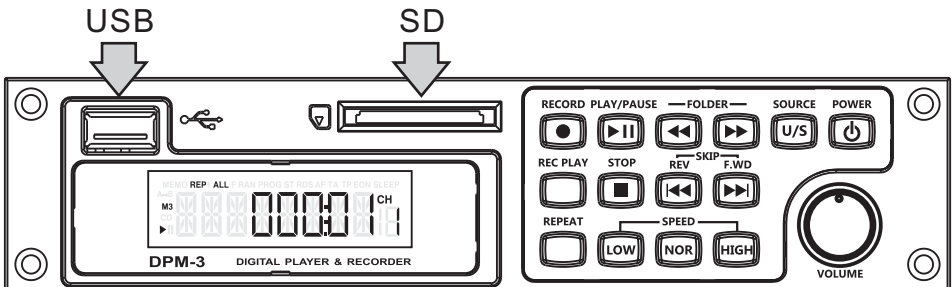

Fig. 4

2. Music Playback:

- (A) Press PLAY/PAUSE **10** for playback. The ► icon and track information will be displayed.
- (B) Press PLAY/PAUSE again during playback to pause. II is displayed. Press PLAY/PAUSE again to resume playback.
- (C) Press STOP to stop playback.
- (D) M3 is displayed when playing MP3.

(E) Repeat tracks:

- (1) "REP 1": Repeat the current track.
- (2) "F": Repeat the tracks at current folder.
- (3) "ALL": Repeat all tracks.
- (4) REP disappears: Stop the repeat function.

(F) SPEED: Allow track to play at an increased (HIGH) or decreased (LOW) speed or Normal speed. Speed can be adjusted in 10 different steps. NOR denotes normal speed.

3. Operating instructions for the order of playing music:

- (A) Copy the desired songs into USB storage unit one by one until copying all the desired songs. By this way, the play sequence will be based upon the order of music being programmed into USB storage unit.
- (B) Number the desired songs when copying them into folders. Then copy the folders into USB storage unit. Please note the songs must be numbered by the same digit like 00, 01, 02 or 000, 001, 002 or 0000, 0001, 0002.. and so on.

4. Record tracks:

- (A) If recording input signals are to be saved into a USB or SD Card, insert a USB or SD card into slot and ascertain the intended Source. Press RECORD **11** and "WAIT REC" will be shown until "STANDBY" is flashing. Then press RECORD to start recording process. Press RECORD button to pause and press RECORD again to record. Press STOP **12** to stop recording and it converts to MP3 format and saved in "REC" folder.
- (B) Recording input can be converted into MP3 (44.1KHz 128Kbps) file format. It can be saved into a USB or SD Card.
- (C) Press REC PLAY **13** to play current recorded track.

5. Play recorded tracks:

- (A) Press REC PLAY after the recording process, it will play the last recorded track. Press STOP and then press REC PLAY, it will play the first track of the REC folder.
- (B) Press REC PLAY to enter into recorded tracks. Press REV/F.WD to search for tracks.

III. Remote Controller Controls, Fig. 5

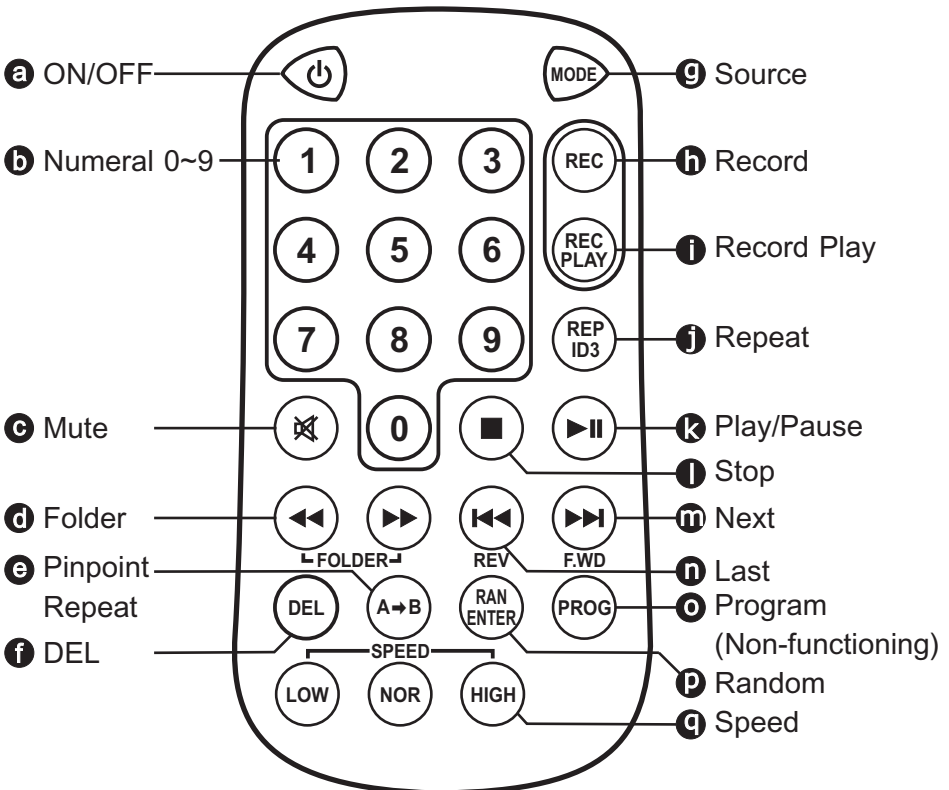

Fig. 5

IV. Remote Controller Functions

1. MUTE: Press to mute, press again to un-mute.
2. Pinpoint Repeat A→B: During playback, press A→B to pinpoint A. Press again to pinpoint B and start to pinpoint repeat playing between A and B. Press it again to cancel the function.
3. DEL: Delete button. Select the to be deleted track during playback. Press DEL button, LCD displays DEL FILE. Press once to delete this track.
4. RAN ENTER: Play random tracks. Press RAN ENTER to play randomly. Or use the REV or F.WD on the control panel or remote controller to play randomly.
5. Numeric selection for tracks:
 - (A) For a lot of tracks, use the remote control number keys to directly go to the specified track. Here are some common examples.
 - (B) ① ➡ ③ ➡ ④ : Press for track #134.
 - (C) ⑥ ➡ ⑧ : Press and wait for 3 seconds for track #68.
6. Other functions refer to the operating instruction of the control panel.

7. Insert Battery to Remote Control, Fig. 6:

- (A) Press down on the small left fixed latch and hold the right side of the battery seat groove gently to pull out the battery holder.
- (B) Insert the new battery with the positive upward and gently push the battery holder inward to position it.
- (C) Note: When using the remote control, the best reception distance is 3 meters from the remote control to the receiving hole on the control panel (effective distance is 5 meters). The battery of remote control is CR2025 3V battery.

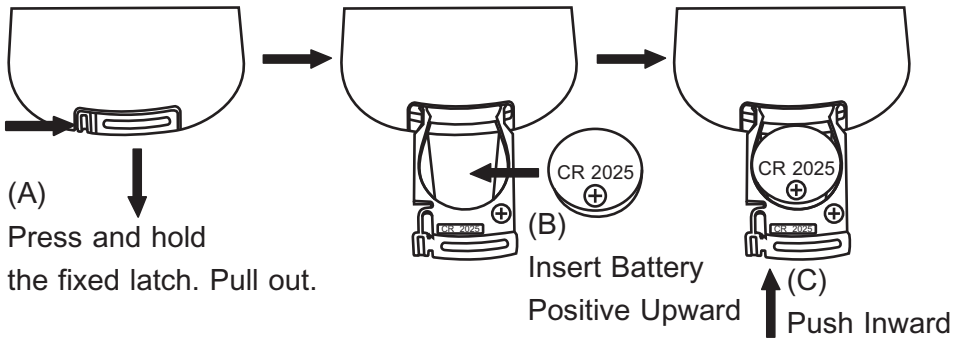

Fig. 6

V. Note

1. Do read this user guide before use.
2. Do not hit the player.
3. Do not place this player near strong magnetic fields and electric fields.
4. Do not disassemble, repair or modify this player.
5. Changes to the characteristics and design of the product will be made without notice.

MIPRO[®]
MICROPHONE PROFESSIONALS

MIPRO Electronics Co., Ltd

Headquarters : 814 Pei-Kang Road, Chiayi, 60096, Taiwan

Tel : +886.5.238.0809

Fax : +886.5.238.0803

www.mipro.com.tw

mipro@mipro.com.tw

All rights reserved. MN 018/10



Do not copy or forward without prior approvals MIPRO.

Specifications and design subject to change without notice.



2 CE579B