

ACT-80 Digital Wireless ENG Receiver

Key Features

- Waterproof, compact, and ultra-thin rugged aluminum housing construction.
- Various interface socket modules can be easily detached and installed to work with different camcorders, active speakers and other audio equipment.
- UHF PLL synthesized circuit and dual-antenna true diversity technology for best reception quality.
- Enhanced RF circuitry improves anti-interference characteristics and system compatibility with a 64 MHz-wide bandwidth, allowing more interference-free channels to be selected.
- Full-range sound quality is not affected by the strength of RF signals or operating distance.
- Digitally-processed RF circuitry and DigitnamicPlus™ technology eliminates compander noise, assuring a wireless sound quality that easily rivals cable transmission.
- Improved proprietary Audio A/D Converter provides a true dynamic range of 115 dBA, T.H.D. < 0.03% at 1 kHz with < 3 ms latency.
- Proprietary 256-bit encryption provides secure audio transmission, preventing unauthorized listening.
- World's first ACT™ (Automatic Channel Targeting) provides precise and rapid frequency sync to the transmitters.
- Digital graphic backlit LCD panel.
- Control panel has setup buttons for SCAN, ACT and AF functions, allowing easy and error-free setup.
- Electronic power switch eliminates popping noise during power on/off.
- Precision SMA antenna connectors with removable soft antennas.
- Features are compatible with MIPRO ACT-8 series digital receivers.



Transmitters

ACT-80H	Handheld Transmitter
ACT-80HC	Rechargeable Handheld Transmitter
ACT-80T	Bodypack Transmitter
ACT-80TC	Rechargeable Bodypack Transmitter
TA-80	Digital Wireless Plug-on Transmitter

Accessories

MJ-90	Power Cord for SONY Camcorders
MR-90S	Standard Package
MR-90S15 / MR-90S25	Exclusive Socket Interface
MR-90SB	Built-in Battery Pack
MR-90SC	Mounting Fasteners

Technical Specifications

Frequency Range	UHF 470 – 937 MHz (country dependent)
Bandwidth	64 MHz
Preset Frequency	12 non-interference compatible frequencies in group 1-10. 16 non-interference compatible frequencies in group 11-16. 216 preset frequencies in total.
Channel Grid	25 kHz
Channel Set-up	Scan & ACT sync
Audio Sampling	24-bit / 44.1 kHz
Audio Compression	2nd Generation DSP inertial coding
Latency	< 3 ms
Frequency Response	20 Hz – 20 kHz (-2dB)
S/N Ratio (analog output)	> 115 dB(A)
T.H.D.	< 0.03 % @ 1 kHz
Encryption	256 bit
Oscillation Mode	PLL Synthesized
Frequency stability	±0.005% (-10 – +60°C)
Image and Spurious Rejection	> 85 dB
Receiving Mode	Digital diversity
Analog Output	Balanced XLR
LCD Display	Frequency, RF / AF meters, Diversity signals and transmitter battery meter
Antenna Input	2 × 50 Ω SMA female connector
Power Supply	External AC power supply, 12 – 15 V DC, 0.5A
Dimensions (W × H × D)	73.5 × 120 × 28 mm 2.9 × 4.7 × 1.1 "
Weight	Approx. 220 g 7.7 oz
Operating Temperature	-10 – +60°C

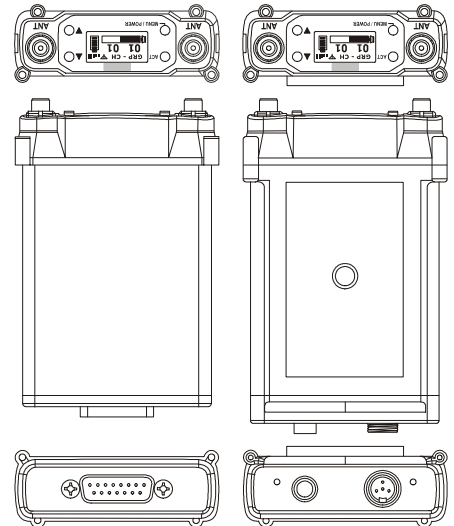

MIPRO Electronics Co., Ltd

Headquarters: 814 Pei-kang Road, Chiayi, 60096, Taiwan
 Tel: +886.5.238.0809 | Fax: +886.5.238.0803
 www.mipro.com.tw | mipro@mipro.com.tw