



ACT-818 Digital Wideband Single-Channel Receiver  
ACT-828 Digital Wideband Dual-Channel Receiver

## User Guide





## ! IMPORTANT SAFETY INSTRUCTIONS !

1. Read these instructions.
2. Keep these instructions.
3. Heed all warnings.
4. Follow all instructions.
5. Do not use this apparatus near water.
6. Clean only with a dry cloth.
7. Do not block any ventilation openings. Install in accordance with the manufacturer's instructions.
8. Do not install near any heat sources such as radiators, heat registers, stoves, or other apparatus (including amplifiers) that produce heat.
9. Do not defeat the safety purpose of the polarised or ground plug: A polarised plug has two blades with one wider than the other. The wide blade is provided for your safety. When the provided plug does not fit into your outlet, consult an electrician for replacement of the obsolete outlet.
10. Protect the power cord from being walked on or pinched particularly at plug, convenience receptacles, and the point where they exit from the apparatus.
11. Only use attachments/accessories specified by the manufacturer.
12. Use only with a cart, stand, tripod, bracket, or table specified by the manufacturer, or sold with the apparatus. When a cart is used, use caution when moving the cart/apparatus combination to avoid injury from tip-over.
13. Unplug this apparatus during lightning storms or when unused for long periods of time.
14. Refer all servicing to qualified service personnel. Servicing is required when the apparatus has been damaged in any way, such as power-supply cord or plug is damaged, liquid has been spilled or objects have fallen into the apparatus, the apparatus has been exposed to rain or moisture, does not operate normally, or has been dropped.
15. To reduce the risk of fire or electric shock, do not expose this apparatus to rain or moisture.
16. Apparatus should not be exposed to dripping or splashing and no objects filled with liquids, should be placed on the apparatus.
17. Use only with the battery which specified by manufacturer.
18. The power supply cord set is to be the main disconnected device.



## WARNING

### 1. FOR OUTDOOR USE:

To reduce the risk of fire or electric shock, do not expose this apparatus to rain or moisture.

### 2. UNDER WET LOCATION:

Apparatus should not be exposed to dripping or splashing and no objects filled with liquids, such as vases should be placed on the apparatus.

### 3. SERVICE INSTRUCTIONS:

**CAUTION** - These servicing instructions are for use by qualified service personnel only. To reduce the risk of electric shock, do not perform any servicing other than that contained in the operating instructions unless you are qualified to do so.



This symbol indicates that dangerous voltage constituting a risk of electric shock is present within this unit.



This symbol indicates that there are important operating and maintenance instructions in the literature accompanying this unit.

## IC-ID

This device complies with RSS-310 of Industry Canada. Operation is subject to the condition that this device does not cause harmful interference.

## FCC

THIS DEVICE COMPLIES WITH PART 15 OF THE FCC RULES OPERATION IS SUBJECT TO THE FOLLOWING TWO CONDITIONS:

- (1) This device may not cause interference.
- (2) This device must accept any interference, including interference that may cause undesired operation of the device. This equipment complies with FCC RF radiation exposure limits set forth for an uncontrolled environment.

## Disposal

Dispose of any unusable devices or batteries responsibly and in accordance with any applicable regulations.



Disposing of used batteries with domestic waste is to be avoided!

Batteries / NiCad cells often contain heavy metals such as cadmium(Cd), mercury(Hg) and lead(Pb) that makes them unsuitable for disposal with domestic waste. You may return spent batteries/ accumulators free of charge to recycling centres or anywhere else batteries/accumulators are sold.

**2005-08-13**

By doing so, you contribute to the conservation of our environment!

---

# I. Part Names, Fig. 1

## 1. ACT-818 Single-Channel

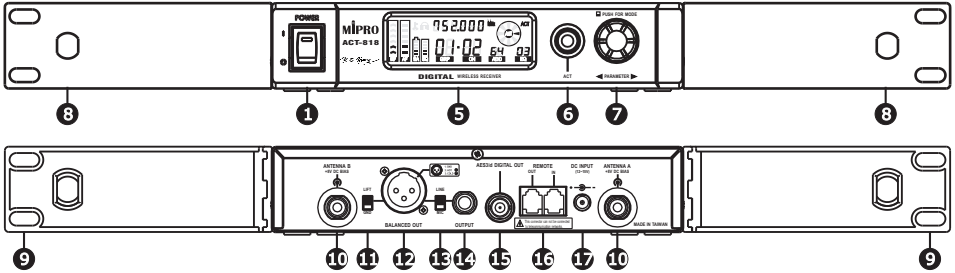

## 2. ACT-828 Dual-Channel

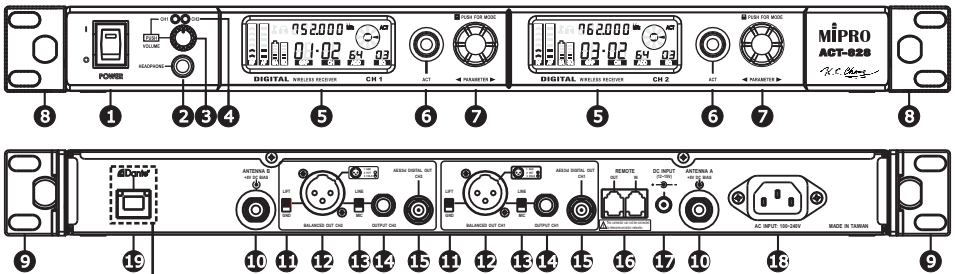

Dante Interface (optional)

Fig. 1

- ❶ Power switch.
- ❷ Headphone Monitor Phone Jack.
- ❸ Headphone Volume Control & channel selector.
- ❹ Channel indicator.
- ❺ Color VFD Screen.
- ❻ ACT button.
- ❼ Rotary Knob.
- ❽ Front panel antenna connector mount holes.

- 9 Rackmount kit.
- 10 Antenna connectors.
- 11 LIFT/GND switch: Switch to GND, pin 1 of the XLR connector is grounded. Switch to LIFT, pin 1 of the XLR connector is lifted. (GND default)
- 12 Analog Balanced Audio Output XLR connector.
- 13 Output Level Switch.
- 14 Unbalanced Audio Output 6.3 $\phi$  Phone Jack.
- 15 AES3id Digital Output Jack.
- 16 Network Interface Connector.
- 17 DC Power Input Jack: Central electrode must be connected to positive.
- 18 AC Power Input Socket.
- 19 Dante Interface (optional).

#### Warning: Avoiding Hearing Damage –

Permanent noise-induced hearing loss may occur on prolonged exposure to loud sounds wearing earphones or headphones.

We recommend you listen responsibly by limiting the amount of time that you use earphones or headphones at high volume.



To prevent possible hearing damage, do not listen at high volume levels for long periods.

## II. Receiver Installation

### ACT-818 Single-Channel

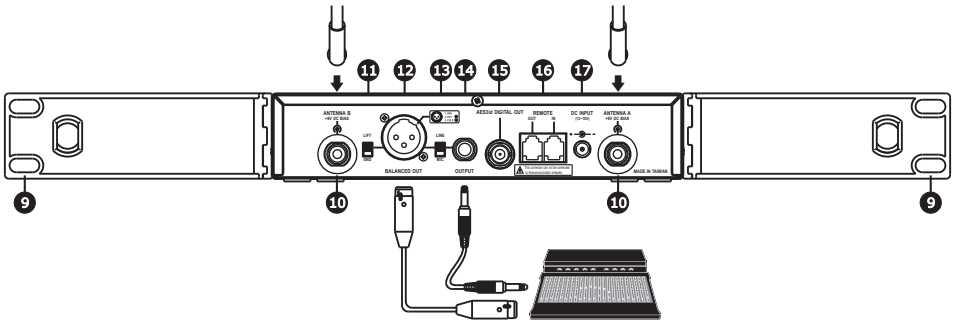

### ACT-828 Dual-Channel

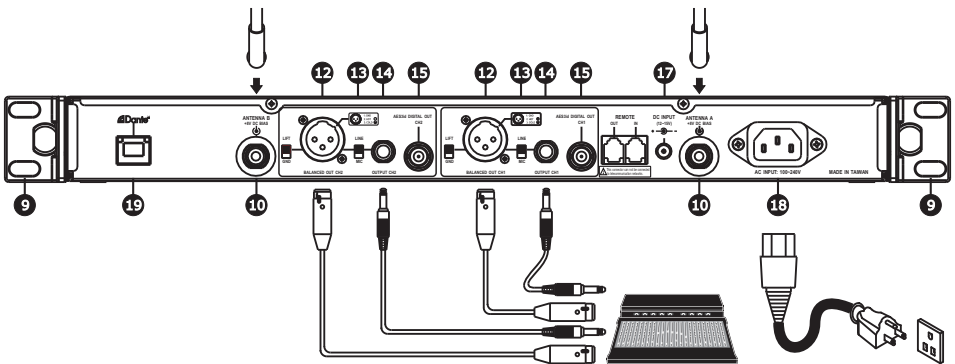

Fig. 2

1. Connect two antennas to each of the antenna connectors **10** on the rear panel, Fig. 2.
2. Power Connection:
  - (A) Connect the power cord to the receiver optional AC power input socket **18** and plug the other end into an AC 100~240V power source, Fig. 2.
  - (B) Connect the power supply to the receiver DC input jack **17** and plug into an AC power source, Fig. 3.



### 3. Audio Output Connection :

- (A) Each channel signal output can be connected to the mixer or amplifier's MIC IN jack by using a cable with balanced XLR connector. 3-pin XLR output wiring diagram, as Fig. 4 shows.

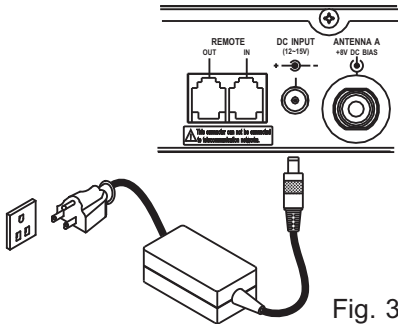

Fig. 3

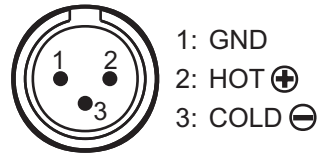

Fig. 4

- (B) Connect unbalanced phone jack **14** to a amplifier LINE IN jack using a 6.3 $\phi$  PHONE cable.
- (C) Volume Switch: Line or Mic level selection. To match input gain of mixer or amplifier.
- (D) LINE output connection: Connect receiver's balanced output connector to the "LINE IN" input connector of mixer or amplifier using the XLR to 6.3 $\phi$  cable and switch the volume switch to "LINE" position.
4. Antenna Connection: antenna connectors provide 8-volt DC bias to work with MIPRO antenna boosters. If the antenna cable is longer than 10 meters, it is recommended to add an antenna booster to ensure optimal reception.

### III. Receiver Operation

1. Before turning on the receiver, ensure all transmitters are powered off and the mixer or amplifier's volume control is minimized. When the receiver is turned on and the VFD screen glows, it is working normally.
2. RF meter level glows when transmitter is powered on. Once audio signal is received from the transmitter, the AF audio meter level glows in accord with signal strength. System is abnormal if RF indicator or AF meter does not glow, then adjustment or repair might be required.
3. The microphone volume is adjusted at the amplifier or mixer. No need for volume adjustment at the receiver.

## IV. Tips for Receiver Installation

1. Single half-rack receiver or Single 1-rack receiver : Install the optional rack mount kit and fasten with screws on both sides, Fig. 5.

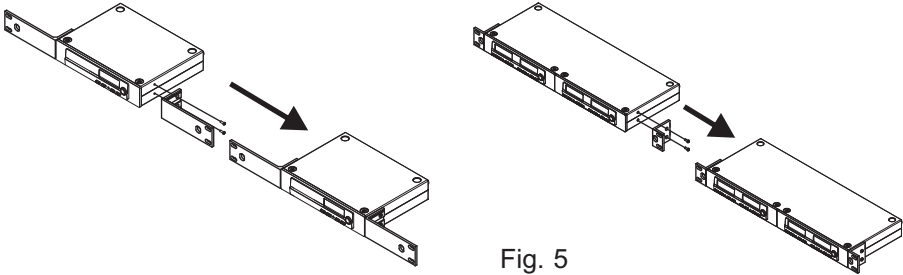

Fig. 5

2. Receiver Rack-Mount Kits, Fig. 6.

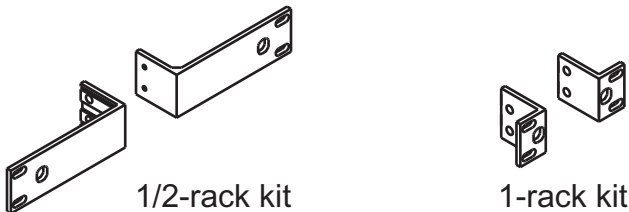

Fig. 6

3. Receivers can be fitted on an EIA standard 19-inch rack case. For improved reception, an optional rear-to-front antenna cable installation through rackmount screw holes ⑨ is highly recommended, Fig. 7.
4. For ideal reception range, install the receiver at least 1 meter above the ground and away from EMI / RFI “noise” sources. In addition, place the transmitter at least 1 meter away from the receiving antenna, as shown Fig. 8.

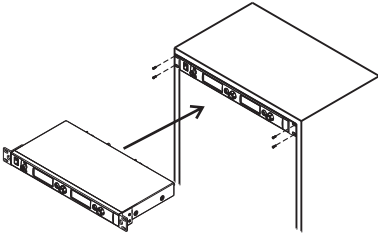

Fig. 7

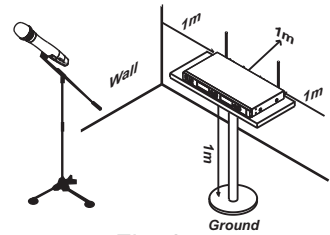

Fig. 8

5. Proper installation of antennas enhances the operating efficiency of receiver. The most important rule is to minimize the distance between the receiving antenna and transmitter for best reception quality.
6. Use MIPRO supplied antennas to ensure proper receiver sensitivity. Use MIPRO's antennas to ensure proper receiving sensitivity
7. Antenna connector provides 8V DC biased output. Short circuits should be avoided.
8. Use Install MIPRO directional antennas and boosters if extended reception distance is required.
9. Use the antenna distributor in the multiple channel wireless systems to simplify the antenna installation and improve receiving efficiency.
10. For multiple compatible systems operation, it is recommended to select MIPRO's factory preset interference-free channels within the same group to ensure optimum performance.

## V. VFD Screen Description

1. VFD Screen Displays functions and parameters, Fig. 9:

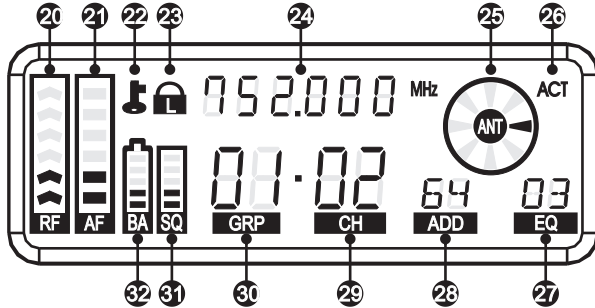

Fig. 9

- |  |                                   |
|--|-----------------------------------|
| ⑳ RF Signal Meter.                         | ㉗ Equalizer and Anti-feedback.    |
| ㉑ Audio Signal Meter.                      | ㉘ PC address code.                |
| ㉒ Encryption status icon.                  | ㉙ Channel.                        |
| ㉓ Panel Lock icon.                         | ㉚ Group.                          |
| ㉔ Working frequency.                       | ㉛ Receiving sensitivity SQ meter. |
| ㉕ Diversity A/B Antenna Signal indicators. | ㉜ Transmitter battery meter.      |
| ㉖ ACT indicator.                           |                                   |

2. Lightening VFD Screen, Fig. 10:

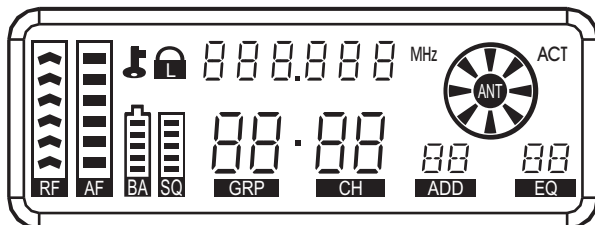

Fig. 10

### 3. The Functions and Parameters:

Use Rotary Knob ⑦ to set functions through the VFD Screen. 8 functions can be programmed, Fig. 11.



Fig. 11

### 4. Programmable Parameters:

(A) SQUELCH Setting, Fig. 12:

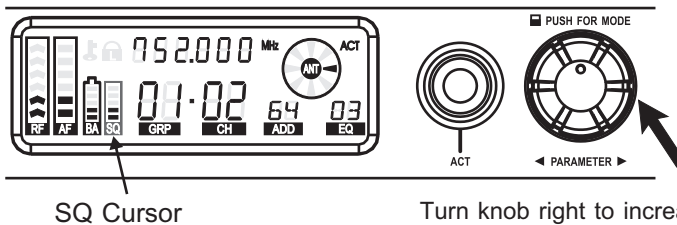

Fig. 12

- (1) Press knob to SQ meter. SQ cursor blinks to denote it is ready to accept parameter changes.
- (2) Turn the knob right to increase indicator grids but it decreases the receiving sensitivity. If turn left to decrease indicator grids and increases sensitivity.
- (3) After changing a parameter, press the knob to save the value. SQ cursor stops blinking.
- (4) The lower the SQ level, the higher sensitivity level is when searching automatically for a non-interference channel. When SQ is set as the highest level, the frequency can be selected forcibly regardless the level of external interferences.
- (5) The SQ setting, regardless high or low, will not affect the receiver's sensitivity during a performance.

(B) GROUP Setting, Fig. 13:

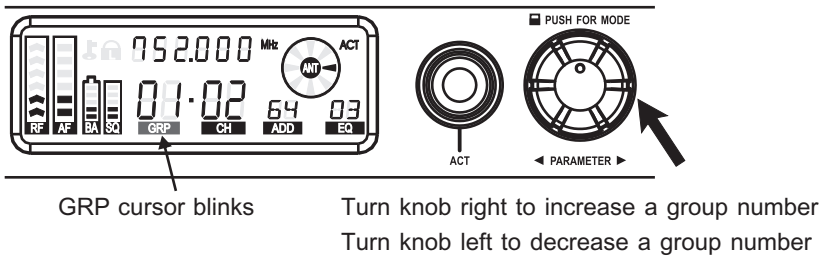
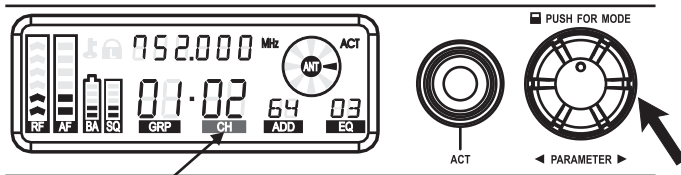

Fig. 13

- (1) Press knob to GRP cursor. GRP cursor blinks to denote it is ready to accept parameter changes.
- (2) Turn knob right to increase or left to decrease a GRP number.
- (3) After changing a parameter, press the knob to save the value. GRP cursor stops blinking.

(C) CHANNEL Setting, Fig. 14:



CH cursor blinks Turn knob right to increase a channel via Auto Scan  
Turn knob left to decrease a channel via Auto Scan

Fig. 14

- (1) Press knob to CH cursor. CH cursor blinks to denote it is ready to accept parameter changes.
- (2) Turn knob right to increase or left to decrease a CH number.
- (3) After changing a parameter, press the knob to save the value. CH cursor stops blinking.
- (4) When SQ is set as the highest level, the frequency can be selected forcibly regardless the level of external interferences.
- (5) Group 16 is last group and can be user-defined. Group 16 enables the user to select and save up to 16 frequencies, Fig. 15:
  - (a) CH cursor starts blinking when last group GRP 16 is shown. Press and hold cursor enters user-defined status. Frequency starts blinking to denote it is ready to accept parameter changes.
  - (b) Turn knob right to increase or left to decrease.
  - (c) Parameter value is programmed by 1MHz and 25kHz step.
  - (d) Press the knob to save the programmed frequencies. Frequency number stops blinking.
  - (e) Only frequencies in the last group can be programmed. Other groups cannot be programmed.



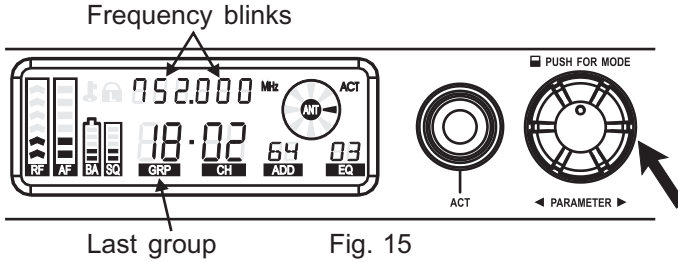

Fig. 15

(D) ANTENNA Setting, Fig. 16:

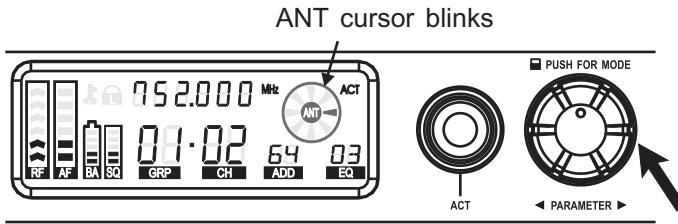

Fig. 16 Three selections available

- (1) Factory default is set at Automatic switching antenna status. Antenna A or B settings can be programmed.
- (2) Press knob to ANT cursor. ANT cursor blinks to denote it is ready to accept parameter changes. Press and hold knob for 2~3 seconds until ANT cursor blinks again. Turn knob left or right to select either Antenna A or Antenna B or Automatic antenna setting, Fig.17.

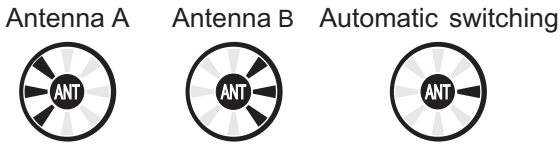
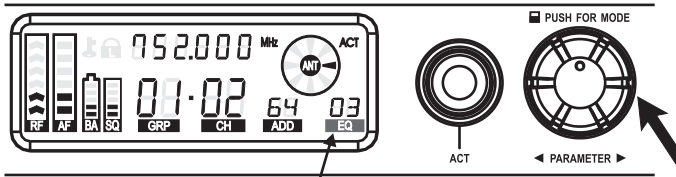

Fig. 17

- (3) Under manual setting, press knob again exits the manual setting or system reboot, system will automatically switch back to Automatic switching antenna setting.
- (4) Antenna A or B setting is provided only for testing and analyzing RF strength of either antenna side during system installation. We highly recommend restoring the setting back to Automatic switching once done with testing.

(E) EQUALIZER Setting, Fig. 18:



EQ cursor blinks

Turn knob right to increase a number  
Turn knob left to decrease a number

Fig. 18

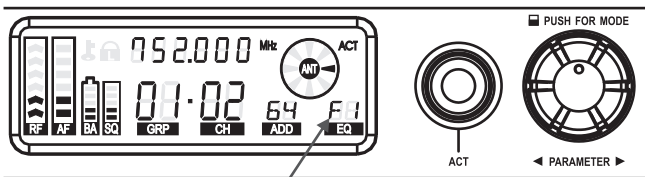

First digit F denotes anti-feedback feature is activated

First digital 0 denotes anti-feedback feature is not activated

Fig. 19

- (1) Press knob to EQ cursor. EQ cursor blinks to denote it is ready to accept parameter changes.
- (2) Turn knob right to increase or left to decrease a number.
- (3) First digit F and 0 will be displayed during knob turning. F denotes anti-feedback feature is activated. 0 denotes anti-feedback feature is not activated.
- (4) Preset EQs enable usage of the same microphone capsule for different equalization to suit artists' preferences and stages.
- (5) EQ will automatically be set to EQ-09 when interfaced with a PC computer. Receiver will transfer the 32 parameters to EQ-09 from PC computer.

(F) PC ADDRESS Setting, Fig. 20:

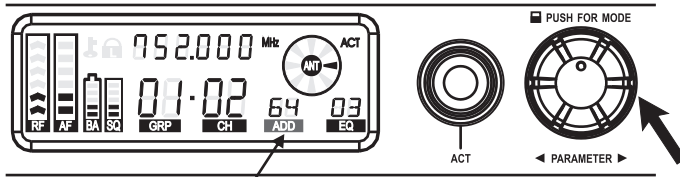

ADD cursor blinks

Turn knob right to increase an address number

Turn knob left to decrease an address number

Fig. 20

- (1) Receiver has ACT-BUS interface. Install MIPRO hardware and software for PC remote-control and monitoring up to 64 MIPRO receiver channels simultaneously.
- (2) Address numbers need to be pre-programmed in advance from 01 ~ 64 before interfacing for network monitoring and control. However, to ensure networking is working properly, all address numbers need to be different from each other to avoid address conflicts.
- (3) Press knob to ADD cursor. Current address number blinks to denote it is ready to accept parameter changes.
- (4) Turn knob right to increase or left to decrease an address number.

(G)  : ENCRYPTION Setting, Fig. 21

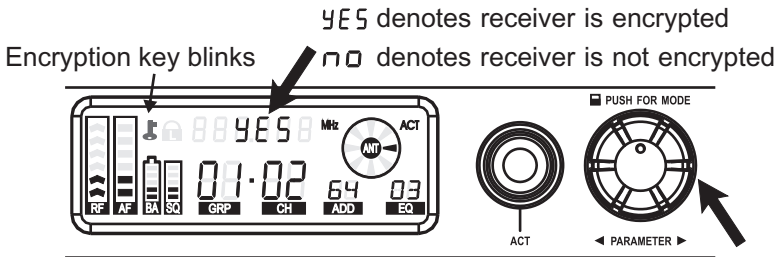





Fig. 21

Turn and press knob to confirm to lock or unlock

- (1) Press knob to  cursor.  cursor blinks to denote it is ready to accept parameter changes. Press and hold knob for 2~3 seconds until "4E5" & "n0" appears interchangeably. "4E5" blinks together with  cursor. Press knob to confirm yes encryption while "4E5" blinks. "n0" blinks without  cursor. Press knob to confirm no encryption while "n0" blinks.
- (2) \*\* Whenever encryption status is changed, press ACT button again to send new encryption key to transmitter. \*\*
- (3) The transmitter can only display encryption status. To activate/deactivate encryption on the transmitter, user must program from receiver and use ACT function to complete the setup.
- (4) The newly encrypted transmitter will work only with the last encrypting receiver and will not work with other receiver even with the same frequency as there will be no audio output.
- (5) The encryption key is randomly generated; hence, a new, secure, encryption key is also downloaded to a transmitter each time an ACT function is synced successfully.

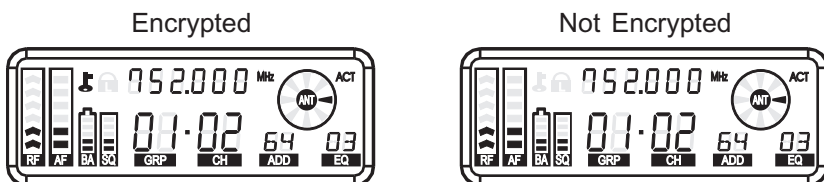
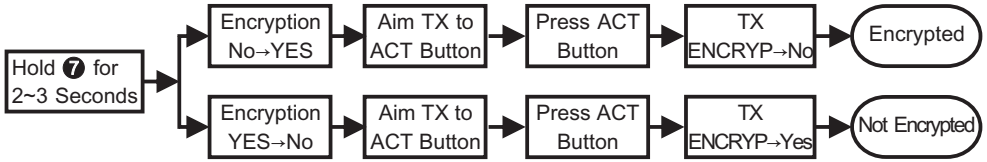

Fig. 22

Encryption Set-up Flow Chart



(H)  : Locked & Unlock Receiver Panel, Fig. 23

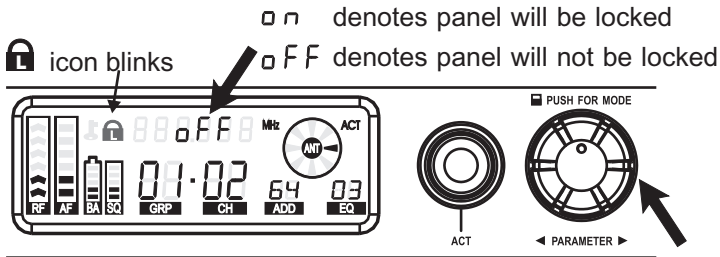













Fig. 23

Turn and press knob to confirm to lock or unlock

- (1) Press knob to  cursor.  cursor blinks to denote it is ready to accept parameter changes. Press and hold knob for 2~3 seconds until “ ” & “ ” appears interchangeably. “ ” blinks together with  cursor. Press knob to confirm lock panel while “ ” blinks. “ ” blinks without  cursor. Press knob to confirm unlock panel while “ ” blinks.
- (2) Receiver parameters can no longer be changed when it is in locked status with  icon. To change parameters you need to unlock the receiver panel first.

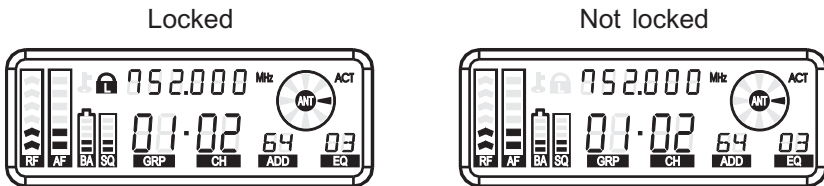

Fig. 24

(I) ACT Sync Set-up:

FAILED denotes a failed sync

ACT indicator is lit

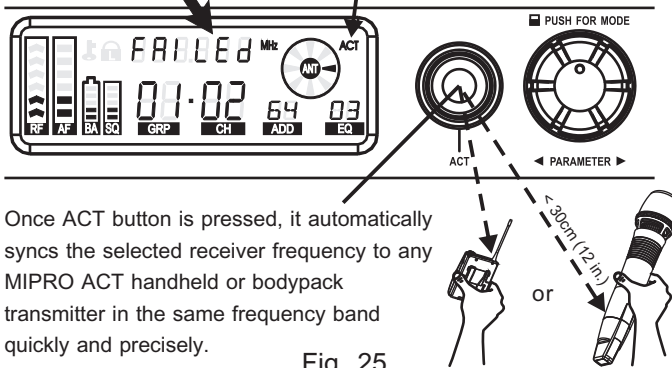

Fig. 25

- (1) Align both infrared ports of transmitter and receiver. Press the ACT button on the receiver, the word "Sync" is displayed to denote channel synchronization is in progress. FAILED appears after 10 seconds if the synchronization was performed unsuccessfully. Repeat ACT synchronization set-up.
- (2) For a successfully ACT channel synchronization, make sure transmitter is powered on, infrared ports are facing each, and within 30cm distance, Fig. 25.
- (3) A successful ACT synchronization transmits both channel and a randomly generated encrypted key to the transmitter.

5. Unchangeable setting display:

(A) Battery Meter: The battery meter is lit when the transmitter is powered on. The battery meter gives a percentage (%) indication of remaining battery life, as shown. Replace with new, fresh batteries when battery indicators fall to 10% (1 indicator remaining), Fig. 26.

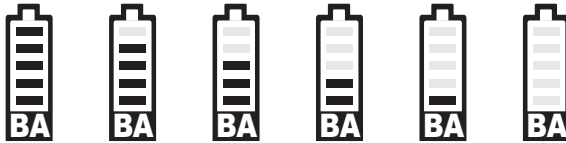

Fig. 26

(B) Error Message: ERR01 indicates internal data error.



## VI. Computer Network Interface Operation

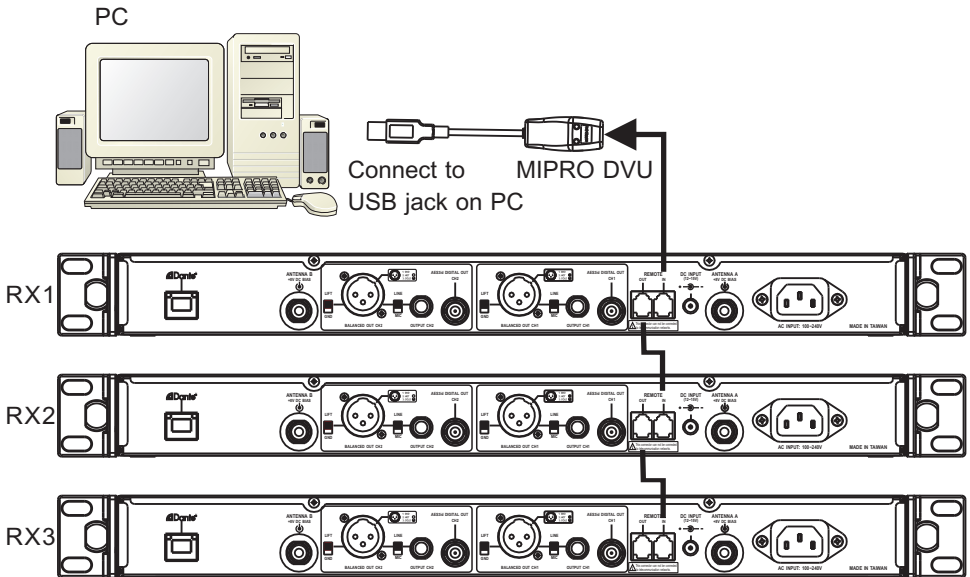

Fig. 27

1. This receiver has advanced computer network-interfaced with MIPRO DV.
2. MIPRO DV Wiring Instructions, Fig. 27:
  - (A) Use supplied hardware cable for serial connection to MIPRO receivers and PC network interface connector 16 .
  - (B) Next, using a USB connector, you can link to a computer USB PORT.
  - (C) Up to 64 MIPRO channels can be connected, remote-controlled and monitored.
  - (D) Best ideal network cable length for optimal transmission quality is less than 100 meters. 100-300 meters cable will have unstable transmission quality.

## VII. Dante Network Interface Operation (Dante interface only)

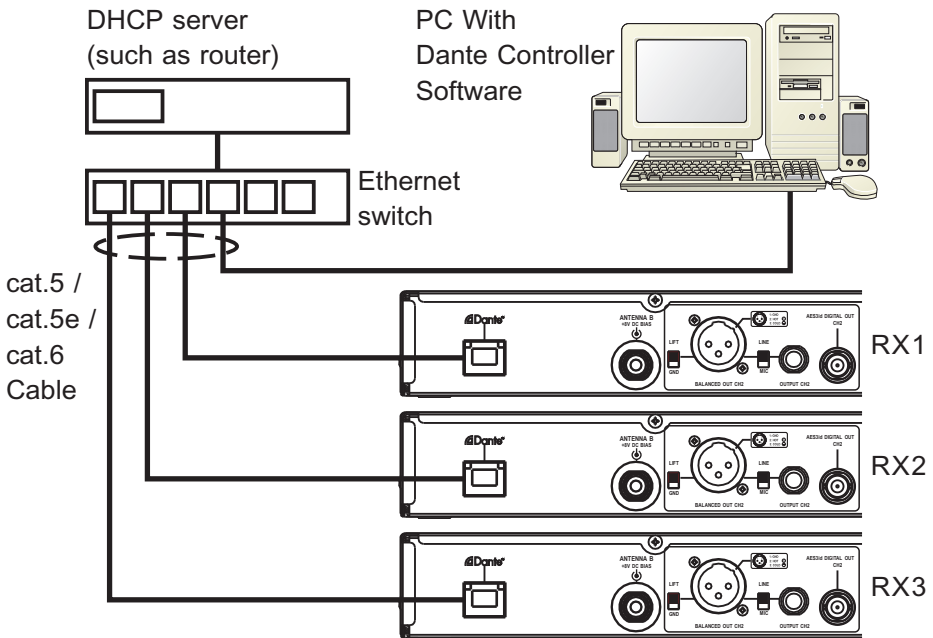

Fig. 28

1. Dante network topology:
  - (A) Connect MIPRO ACT-828 via Dante port by Cat.5, Cat.5e, or Cat.6 cable with Ethernet switch to construct Dante network, Fig. 28.
  - (B) Note : The Ethernet switch should build-in DHCP function or external connected with a DHCP server such as network router.
2. Software Operation: Install Dante Controller software in PC to perform audio stream routing and monitoring.
3. The free Windows and Mac OS X software and user guide of Dante Controller can be downloaded at the website of Audinate. <https://www.audinate.com/products/software/dante-controller>



**MIPRO**<sup>®</sup>  
MICROPHONE PROFESSIONALS

**MIPRO Electronics Co., Ltd**

Headquarters : 814 Pei-Kang Road, Chiayi, 60096, Taiwan

Tel : +886.5.238.0809

Fax : +886.5.238.0803

[www.mipro.com.tw](http://www.mipro.com.tw)

[mipro@mipro.com.tw](mailto:mipro@mipro.com.tw)

All rights reserved. MN 018/07

Do not copy or forward without prior approvals MIPRO.

Specifications and design subject to change without notice.



2 CE575B