

Touchboards

205 Westwood Ave, Long Branch, NJ 07740
Phone: 866-94 BOARDS (26273) / (732)-222-1511
Fax: (732)-222-7088 | E-mail: sales@touchboards.com

MIPRO®

VM-10

Violin Microphone Kit

VT-20/VT-30/VT-50/VT-70

Wireless Violin Transmitter Kit

User Guide



MIPRO

 MIPRO Electronics Co., Ltd.

Headquarters: 814 Pei-Kang Road, Chiayi, 60096, Taiwan.

Web: www.mipro.com.tw

E-mail: mipro@mipro.com.tw



AS120715

Design and specifications are subject to change without prior notice

Profile

The musical instrument microphone kits are years of collaborations with professional musicians. The key features are it fits snugly, easy to install & remove and protects the expensive musical instruments from surface scratches. Strategically placed in discreet positions that will pick up accurate acoustic reproduction during performance without the handling, movement and hitting noises.

FC & IC - ID

THIS DEVICE COMPLIES WITH PART 74 OF THE FCC RULES AND RSS-123 ISSUE2 OF CANADA. OPERATION IS SUBJECT TO THE FOLLOWING TWO CONDITIONS:

- (1) This device may not cause interference.
- (2) This device must accept any interference, including interference that may cause undesired operation of the device. This equipment complies with FCC RF radiation exposure limits set forth for an uncontrolled environment.

VM-10 Violin Microphone Kit included components:

VM-10M Violin Microphone

VM-10C Violin Microphone Cable

VM-10H Violin Microphone Clip

VT-20 Wireless Violin Transmitter Kit included components:

VT-20H

ACT-20T(VT) Miniature Transmitter

VT-30 Wireless Violin Transmitter Kit
included components:

VT-20H Violin Transmitter Holder

ACT-20T(VT) Miniature Transmitter

Ideal for **ACT-311/ACT-312** receiver.

VT-50 Wireless Violin Transmitter Kit
included components:

VT-20H Violin Transmitter Holder

ACT-20T(VT) Miniature Transmitter

Ideal for **ACT-515** receiver.

VT-70 Wireless Violin Transmitter Kit
included components:

VT-20H Violin Transmitter Holder

ACT-20T(VT) Miniature Transmitter

Ideal for **ACT-717/ACT-727/ACT-747** receiver.

VM-10M Violin Microphone

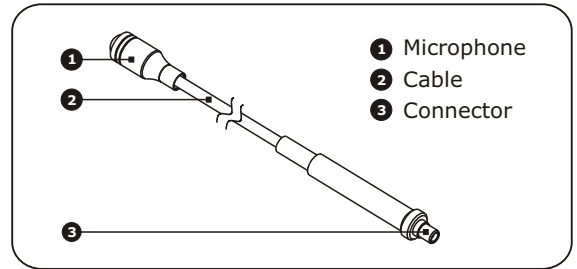

VM-10C Violin Microphone Cable

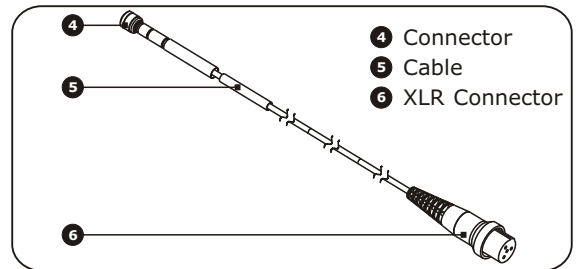

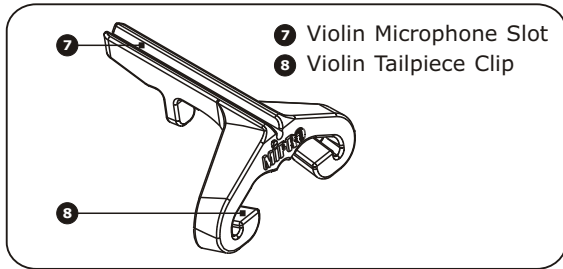
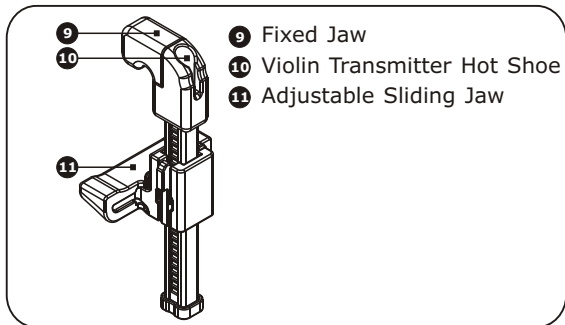
VM-10H Violin Microphone Clip**VT-20H** Violin Transmitter Holder**VM-10 Wireless Transmission Illustration**

- Attach VM-10M onto VM-10H.
- Clip VM-10H onto violin's tailpiece with the microphone placed over fine tuners. Ascertain the microphone tip does not extend beyond the bridge so it will not interfere with bow during performance.
- Connect VM-10M to VM-10C and to any MIPRO bodypack transmitter for a wireless transmission. (see diagram 1)

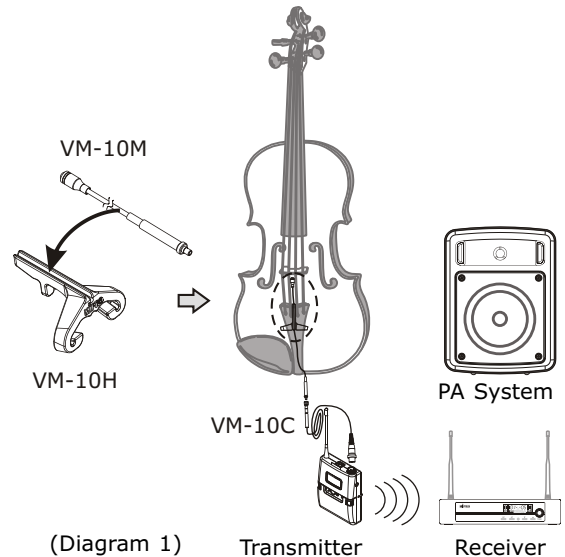

Transmitter Controls & Indicators

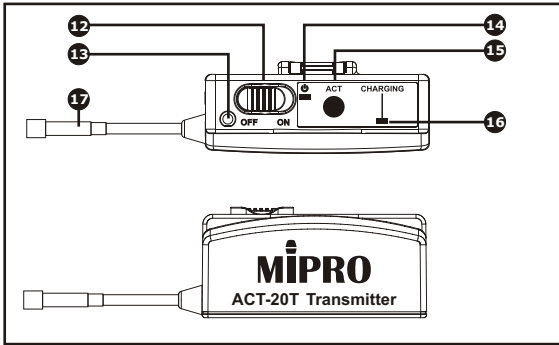

12 Power On/Off Switch

13 Charging Socket: Use supplied charger only.

14 Power Indicator:

Fresh Battery - The Power Indicator will illuminate for 1 second and extinguish after power is turned on.

Low Battery - The Power Indicator will flash continuously indicating the battery level is low and needs to be recharged within 10 minutes.

Successful ACT syncing: The Power Indicator will illuminate for 1 second and extinguish after channels are synchronized successfully.

Unsuccessful ACT syncing: The Power Indicator will flash continuously for 5-6 seconds. Check to see if different transmitter and receiver frequency bands are used.

15 ACT (IR) Port: Align both receiver and transmitter ACT ports within 30cm of each other when the ACT button on the receiver is pressed for a successful ACT synchronization.

16 Charging Indicator: Red LED indicator denotes charging; Green LED indicator denoted charged and ready. Fully charge may take up to 3-4 hours.

17 Connecting Cable and Connector

Charging the ACT-20T(VT)

- Power off transmitter.
- Plug the supplied charger into the AC mains input socket and then plug it into ACT-20T(VT).
- Do not use charger from other brands to avoid insufficient voltage or current.
- Do not exceed the input supply voltage as it may damage the battery charger, rechargeable battery and transmitter itself. The output of MIPRO DC power supply is 12V/0.2A.

Viewing Charging Status

- Charging: Red LED indicator.
- Charged: Green LED indicator.

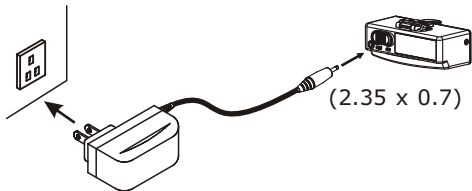

Note:

Rechargeable batteries have a limited number of charge cycles and may eventually need to be replaced. Battery life and number of charge cycles vary by useage and user settings.

VT-20 Wireless Transmission Illustration

- Mount ACT-20T(VT) onto hot spot of VT-20H.
- Height of *Adjusting Sliding Jaw (ASJ) can be adjusted by squeezing the side springs using the thumb and index finger together.
- Carefully mount VT-20H onto violin with thumb & index finger in one hand and the thumb & index finger in the other hand to adjust for ideal height & tension (see diagram 2)
- VT-20 kit is designed for performers having existing MIPRO receivers.
- VT-20 kit includes VT-20H, ACT-20T(VT) and requires VM-10H & VM-10M.

- * Forcing adjusting slide jaw up & down without pressing the side may damage the mechanical part.

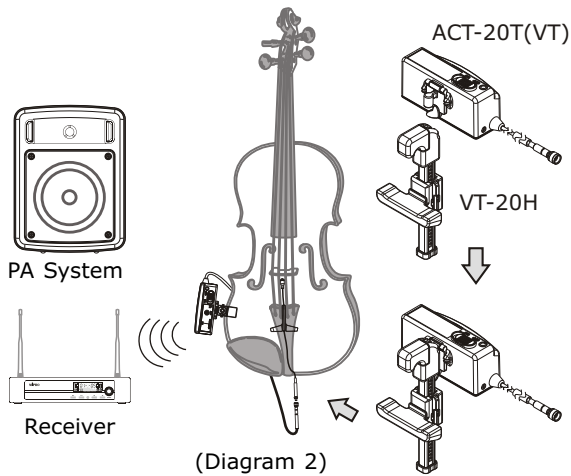

VT-30/VT-50/VT-70 Wireless Transmission Illustration

- Mount ACT-20T(VT) onto hot spot of VT-20H.
 - Height of *Adjusting Sliding Jaw (ASJ) can be adjusted by squeezing the side springs using the thumb and index finger together.
 - Carefully mount VT-20H onto violin with thumb & index finger in one hand and the thumb & index finger in the other hand to adjust for ideal height & tension (see diagram 3)
 - VT-30 kit is designed with MIPRO ACT-311/ACT-312 diversity receiver, VT-20H and ACT-20T(VT). Ideal for smaller crowds.
 - VT-50 kit is designed with MIPRO ACT-515 true diversity receiver, VT-20H and ACT-20T(VT). Ideal for medium crowds.
 - VT-70 kit is designed with MIPRO ACT-717/ACT-727/ACT-747 true diversity receiver, VT-20H and ACT-20T(VT). Ideal for large crowds in large professional venues.
- * Forcing adjusting slide jaw up & down without pressing the side may damage the mechanical part.

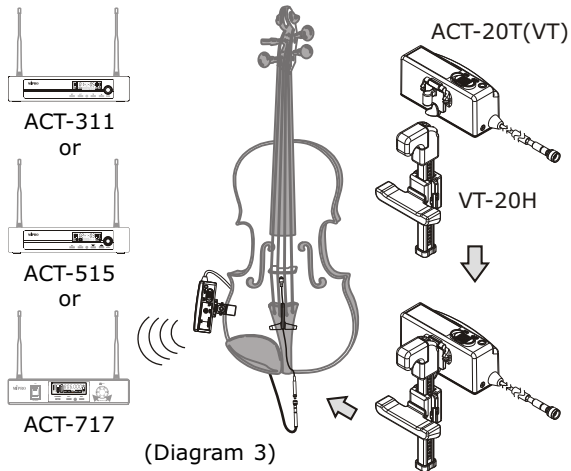

Connection ACT-20T(VT) Miniature Transmitter & VT-20H Violin Transmitter Holder

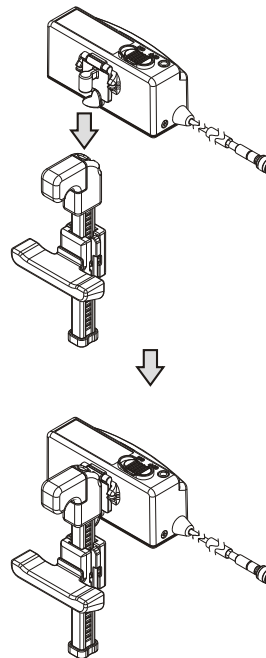

VM-10 Wired Transmission Illustration

- Attach VM-10M onto VM-10H.
- Clip VM-10H onto violin's tailpiece with the microphone placed over fine tuners. Ascertain the microphone tip does not extend beyond the bridge so it will not interfere with bow during performance. (see diagram 4)
- Connect VM-10C Violin Microphone Cable onto a MIPRO MJ-53 Condenser Microphone Adaptor. MJ-53 provides 12V~48V DC phantom power with a XLR output to the mixer input for a wired transmission. (see diagram 4)

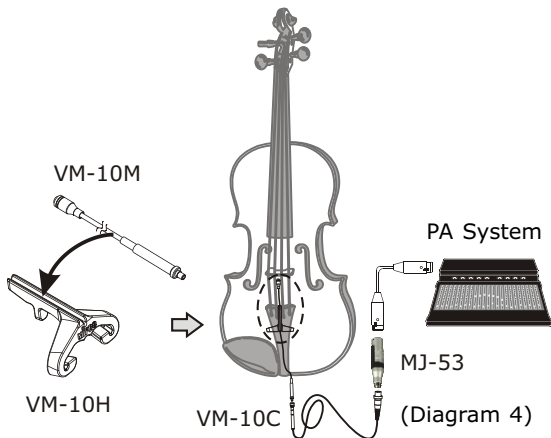

Illustration

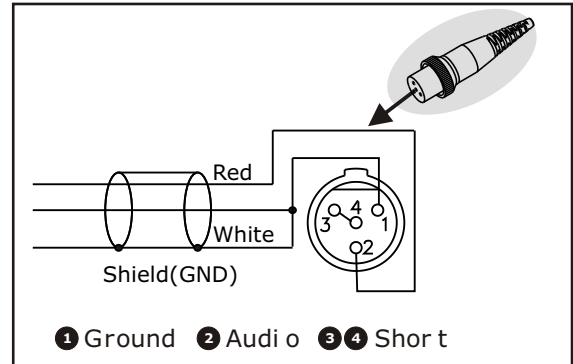

Disposal



2005-08-13

Dispose of any unusable devices or batteries responsibly and in accordance with any applicable regulations.

Disposing of used batteries with domestic waste is to be avoided!

Batteries / NiCad cells often contain heavy metals such as cadmium(Cd), mercury(Hg) and lead(Pb) that makes them unsuitable for disposal with domestic waste. You may return spent batteries/ accumulators free of charge to recycling centres or anywhere else batteries/accumulators are sold.

By doing so, you contribute to the conservation of our environment!