

UNI-T

MSO8000HD Series Mixed Signal Oscilloscope

20GSa/s | 8GHz | 2Gpts | 1,000,000wfms/s



User's Manual REV.2.0

2025.06

Table of Contents

Introduction.....	6
Copyright Information.....	6
Trademark.....	7
File Version.....	7
Statement.....	7
Safety Requirement.....	7
Environmental Requirements.....	12
Connecting Power Supply.....	13
Electrostatic Protection.....	13
File Format.....	14
MSO8000HD Series Mixed Signal Oscilloscope.....	15
Main Features.....	16
1. Quick Guide.....	17
1.1 General Inspection.....	17
1.2 Before Use.....	18
1.3 External Dimension.....	20
1.4 Front Panel.....	21
1.5 Rear Panel.....	22
1.6 Operation Panel.....	23
1.7 User's Interface.....	27
1.8 Touch Screen.....	31
1.9 Virtual Keyboard.....	33
1.10 Numeric Keyboard.....	34
2. Vertical System.....	35
2.1 Open/Activate/Close Analog Channel.....	36
2.2 Channel Coupling.....	37
2.3 Bandwidth Limit.....	37
2.4 Vertical Scale.....	37
2.5 Vertical Position.....	38
2.6 Offset Voltage.....	39
2.7 Unit.....	40
2.8 Reversed Phase.....	40
2.9 Tab.....	40
2.10 Probe Multiplying Power.....	41
2.11 Spare Units.....	42
2.12 Setting channel delay.....	42

2.13 Channel Copy.....	43
3. Horizontal System.....	44
3.1 Horizontal Scale.....	44
3.2 Horizontal Delay.....	45
3.3 Roll Mode.....	46
4. Sampling System.....	47
4.1 Sampling Rate.....	47
4.2 Acquisition Mode.....	50
4.3 Storage Depth.....	52
4.4 ERes.....	53
5. Trigger System.....	54
5.1 Noun of Trigger System.....	54
5.2 Edge Trigger.....	57
5.3 Pulse Width Trigger.....	58
5.4 Video Trigger.....	58
5.5 Slope Trigger.....	59
5.6 Runt Pulse Trigger.....	61
5.7 Delay Trigger.....	63
5.8 Timeout Trigger.....	64
5.9 Duration Trigger.....	65
5.10 Setup & Hold Trigger.....	66
5.11 N-th Edge.....	67
5.12 Pattern.....	68
5.13 Serial.....	69
5.14 Zone Trigger.....	80
6. Protocol Decoding (Option).....	82
6.1 RS232.....	82
6.2 I2C.....	85
6.3 SPI.....	87
6.4 CAN.....	89
6.5 CAN-FD.....	92
6.6 LIN.....	94
6.7 FlexRay.....	95
6.8 AudioBus.....	97
6.9 MIL-STD-1553.....	100
6.10 ARINC429.....	103
6.11 SENT.....	105
7. Automatic Measurement.....	109

7.1 Parameter Measurement	109
7.2 Parameter Snapshot	112
7.3 Add Measurement Parameter	113
7.4 Measurement Statistics.....	113
7.5 Threshold Measurement.....	114
7.6 Measure Operations	114
7.7 Reset Statistics.....	115
7.8 Delete Measure.....	115
8. Cursor Measurement	117
8.1 Time-domain Cursor.....	118
8.2 Frequency-domain Cursor.....	119
9. Mathematical Operation	121
9.1 Basic Operation.....	121
9.2 FFT.....	121
9.3 Filter	124
9.4 Advanced Operation.....	128
9.5 User-defined Operation.....	130
9.6 Multiple Windows	132
10. Reference Waveform.....	133
10.1 Open Reference Function.....	133
10.2 Adjust Reference Waveform.....	133
10.3 Close Reference Waveform.....	134
11. Pass/Fail Test.....	135
11.1 Limit Test.....	135
11.2 Standard Mask test	137
11.3 Save Settings.....	138
12. Digital Channel (Option)	139
12.1 Open/Close the digital channel.....	139
12.2 Chose the logical channel.....	140
12.3 Setting the waveform size	141
12.4 Setting the threshold level and hysteresis.....	141
13. Digital Voltmeter and Frequency Counter	142
13.1 Digital Voltmeter	142
13.2 Frequency counter.....	142
14. Power Analysis (Option).....	144
14.1 Input Analysis.....	144
14.1.1 Power Quality Analysis.....	144
14.1.2 Harmonic Analysis	147

14.1.3 Inrush Current	149
14.2 Output Analysis	151
14.2.1 Ripple Analysis	151
14.2.2 Power Efficiency.....	153
14.2.3 Turn On/Off Time	154
14.2.4 Modulation Analysis.....	157
14.3 Switching Analysis	159
14.3.1 Switching Loss	159
14.3.2 Safety Operation Area	161
14.3.3 Rds(on)	163
14.3.4 Slew Rate.....	164
14.4 Frequency Response Analysis.....	166
14.4.1 PSRR	166
14.4.2 Loop Analysis.....	168
15. Jitter Analysis and Eye diagram (Option).....	171
15.1 Eye-diagram	172
15.2 Measuring Parameter of Eye Diagram.....	174
15.3 Jitter Analysis.....	175
15.4 Clock Recovery	177
15.5 Jitter Resolving.....	177
15.6 Measuring Parameter of Jitter.....	179
15.7 Effect of Test System on Jitter Test	179
16. Consistency Analysis (Optional).....	181
17. Sequence Mode.....	182
17.1 Setting the sequence mode.....	182
17.2 Single Frame Mode	183
17.3 Consecutive Frame.....	184
18. XY Mode.....	186
19. Histogram	190
19.1 Statistical Histogram.....	190
19.2 Regional Histogram.....	192
20. Function/Arbitrary Waveform Generator (Option)	194
20.1 Turn on/off Function/Arbitrary Waveform Generator	194
20.2 Output Continuous Wave Signal.....	195
20.3 Output Modulating Signal.....	198
20.4 Output Sweep Frequency Signal.....	201
21. Search and Navigation.....	204
22. Window Display Setting.....	208

22.1 Marker Display	208
22.2 Persistence	209
22.3 Grid Type	209
22.4 Waveform Type	210
22.5 Brightness	211
23. Storage and Print.....	212
23.1 Waveform Storage and Reloading.....	212
23.2 Screen Image Storage.....	213
23.3 Storage Setting and Reading.....	215
23.4 Deep Storage Data Export.....	216
23.5 External Storage and Loading.....	216
23.6 Data Export.....	218
24. System Setting	219
24.1 Display Setting.....	219
24.2 Automatic Setting and Calibration.....	219
24.3 Communication.....	220
24.4 Auxiliary Input and Output.....	222
24.5 Self Test.....	223
24.6 Other Setting.....	224
25. Remote Control.....	236
25.1 User-defined Programming.....	236
25.2 PC Software Control.....	236
25.3 Web Server	237
26. Troubleshooting.....	241
27. Appendix.....	243
27.1 Appendix A Accessory and Option.....	243
27.2 Appendix B Maintenance and Cleaning.....	247
27.3 Appendix C Warranty Overview	248
27.4 Appendix D Contact Us	248

Introduction

This manual includes the safety requirements, installment and the operation of MSO8000HD series oscilloscope.

Copyright Information

Copyright is owned by Uni-Trend Technology (China) Co., Ltd.

If the original purchaser sells or transfers the product to a third party within three year from the date of purchase of the product, the warranty period of three year shall be from the date of the original purchase from UNI-T or an authorized UNI-T distributor. Power cords, accessories and fuses, etc. are not included in this warranty.

If the product is proved to be defective within the warranty period, UNI-T reserves the rights to either repair the defective product without charging of parts and labor, or exchange the defected product to a working equivalent product (determined by UNI-T). Replacement parts, modules and products may be brand new, or perform at the same specifications as brand new products. All original parts, modules, or products which were defective become the property of UNI-T.

The "customer" refers to the individual or entity that is declared in the guarantee. In order to obtain the warranty service, "customer" must inform the defects within the applicable warranty period to UNI-T, and perform appropriate arrangements for the warranty service.

The customer shall be responsible for packing and shipping the defective products to the individual or entity that is declared in the guarantee. In order obtain the warranty service, customer must inform the defects within the applicable warranty period to UNI-T, and perform appropriate arrangements for the warranty service. The customer shall be responsible for packing and shipping the defective products to the designated maintenance center of UNI-T, pay the shipping cost, and provide a copy of the purchase receipt of the original purchaser. If the products is shipped domestically to the purchase receipt of the original purchaser. If the product is shipped to the location of the UNI-T service center, UNI-T shall pay the return shipping fee. If the product is sent to any other location, the customer shall be responsible for all shipping, duties, taxes, and any other expenses.

The warranty is inapplicable to any defects, failures or damages caused by accident, normal wear of components, use beyond specified scope or improper use of product, or improper or insufficient

maintenance. UNI-T is not obliged to provide the services below as prescribed by the warranty:

- Repair damage caused by installation, repair or maintenance of personnel other than service representatives of UNI-T;
- Repair damage caused by improper use or connection to incompatible equipment;
- Repair any damages or failures caused by using power source not provided by UNI-T;
- Repair products that have been changed or integrated with other products (if such change or integration increases time or difficulty of repair).

The warranty is formulated by UNI-T for this product, replacing any other express or implied warranties. UNI-T and its distributors refuse to give any implied warranty for marketability or applicability for special purpose. For violation of the warranty, repair or replacement of defective products is the only and all remedial measure UNI-T provides for customers. No matter whether UNI-T and its distributors are informed of any possible indirect, special, occasional or inevitable damage in advance, they assume no responsibility for such damage.

Trademark

UNI-T is the registered trademark of Uni-Trend Technology (China) Co., Ltd.

File Version

MSO8000HD-V2.0



Statement











- UNI-T products are protected by patent rights in China and foreign countries, including issued and pending patents.
- UNI-T reserves the rights to any product specification and pricing changes.
- UNI-T reserves all rights. Licensed software products are properties of UNI-T and its subsidiaries or suppliers, which are protected by national copyright laws and international treaty provisions. Information in this manual supersedes all previously published versions.
- Technical data are subject to change without prior notice.





Safety Requirement

This section contains information and warnings that must be followed to keep the instrument

operating under safety conditions. In addition, user should also follow the common safety procedures.

Safety Precautions		
Warning	Please follow the following guidelines to avoid possible electric shock and risk to personal safety.	
	Users must follow the following conventional safety precautions in operation, service and maintenance of this device. UNI-T will not be liable for any personal safety and property loss caused by the user's failure to follow the following safety precautions. This device is designed for professional users and responsible organizations for measurement purposes. Do not use this device in any way not specified by the manufacturer. This device is only for indoor use unless otherwise specified in the product manual.	
Safety Statement		
Warning	“Warning” indicates the presence of a hazard. It reminds users to pay attention to a certain operation process, operation method or similar. Personal injury or death may occur if the rules in the “Warning” statement are not properly executed or observed. Do not proceed to the next step until you fully understand and meet the conditions stated in the “Warning” statement.	
Caution	“Caution” indicates the presence of a hazard. It reminds users to pay attention to a certain operation process, operation method or similar. Product damage or loss of important data may occur if the rules in the “Caution” statement are not properly executed or observed. Do not proceed to the next step until you fully understand and meet the conditions stated in the “Caution” statement.	
Note	“Note” indicates important information. It reminds users to pay attention to procedures, methods and conditions, etc. The contents of the “Note” should be highlighted if necessary.	
Safety Sign		
	Danger	It indicates possible danger of electric shock, which may cause personal injury or death.
	Warning	It indicates that you should be careful to avoid personal injury or product damage.

	<p>Caution</p>	<p>It indicates possible danger, which may cause damage to this device or other equipment if you fail to follow a certain procedure or condition. If the “Caution” sign is present, all conditions must be met before you proceed to operation.</p>
	<p>Note</p>	<p>It indicates potential problems, which may cause failure of this device if you fail to follow a certain procedure or condition. If the “Note” sign is present, all conditions must be met before this device will function properly.</p>
	<p>AC</p>	<p>Alternating current of device. Please check the region’s voltage range.</p>
	<p>DC</p>	<p>Direct current device. Please check the region’s voltage range.</p>
	<p>Grounding</p>	<p>Frame and chassis grounding terminal</p>
	<p>Grounding</p>	<p>Protective grounding terminal</p>
	<p>Grounding</p>	<p>Measurement grounding terminal</p>
	<p>OFF</p>	<p>Main power off</p>
	<p>ON</p>	<p>Main power on</p>
	<p>Power Supply</p>	<p>Standby power supply: when the power switch is turned off, this device is not completely disconnected from the AC power supply.</p>
<p>CAT I</p>	<p>Secondary electrical circuit connected to wall sockets through transformers or similar equipment, such as electronic instruments and electronic equipment; electronic equipment with protective measures, and any high-voltage and low-voltage circuits, such as the copier in the office.</p>	
<p>CAT II</p>	<p>Primary electrical circuit of the electrical equipment connected to the indoor socket via the power cord, such as mobile tools, home appliances, etc. Household appliances, portable tools (e.g. electric drill), household sockets, sockets more than 10 meters away from CAT III circuit or sockets more than 20 meters away from CAT IV circuit.</p>	

CAT III	Primary circuit of large equipment directly connected to the distribution board and circuit between the distribution board and the socket (three-phase distributor circuit includes a single commercial lighting circuit). Fixed equipment, such as multi-phase motor and multi-phase fuse box; lighting equipment and lines inside large buildings; machine tools and power distribution boards at industrial sites (workshops).
CAT IV	Three-phase public power unit and outdoor power supply line equipment. Equipment designed to “initial connection”, such as power distribution system of power station, power instrument, front-end overload protection, and any outdoor transmission line.
 Certification	CE indicates a registered trademark of EU.
 Certification	UKCA indicates a registered trademark of British.
 Certification	Complies with UL STD 61010-1, 61010-2-030 and CSA STD C22.2 No.61010-1 and 61010-2-030.
 Waste	Do not leave the device and its accessories in the trash. Items must be properly disposed of in accordance with local regulations.
 EFUP	This environment-friendly use period (EFUP) mark indicates that dangerous or toxic substances will not leak or cause damage within this indicated time period. The environment-friendly use period of this product is 40 years, during which it can be used safely. Upon expiration of this period, it should enter the recycling system.
Safety Requirement	
Warning	
Preparation before use	<p>Please connect this device to AC power supply with the power cable provided.</p> <p>The AC input voltage of the line reaches the rated value of this device. See the product manual for specific rated value.</p> <p>The line voltage switch of this device matches the line voltage;</p> <p>The line voltage of the line fuse of this device is correct.</p>
Check all terminal rated values	Please check all rated values and marking instructions on the product to avoid fire and impact of excessive current. Please consult the product manual for detailed rated values before connection.

Use the power cord properly	You can only use the special power cord for the instrument approved by the local and state standards. Please check whether the insulation layer of the cord is damaged or the cord is exposed, and test whether the cord is conductive. If the cord is damaged, please replace it before using the instrument.
Instrument Grounding	To avoid electric shock, the grounding conductor must be connected to the ground. This product is grounded through the grounding conductor of the power supply. Please be sure to ground this product before it is powered on.
AC power supply	Please use the AC power supply specified for this device. Please use the power cord approved by your country and confirm that the insulation layer is not damaged.
Electrostatic prevention	This device may be damaged by static electricity, so it should be tested in the anti-static area if possible. Before the power cable is connected to this device, the internal and external conductors should be grounded briefly to release static electricity. The protection grade of this device is 4 kV for contact discharge and 8kV for air discharge.
Measurement accessories	Measurement accessories are of lower class, which are definitely not applicable to main power supply measurement, CAT II, CAT III or CAT IV circuit measurement.
Use the input / output port of this device properly	Please use the input / output ports provided by this device in a properly manner. Do not load any input signal at the output port of this device. Do not load any signal that does not reach the rated value at the input port of this device. The probe or other connection accessories should be effectively grounded to avoid product damage or abnormal function. Please refer to the product manual for the rated value of the input / output port of this device.
Power fuse	Please use power fuse of specified specification. If the fuse needs to be replaced, it must be replaced with another one that meets the specified specifications by the maintenance personnel authorized by UNI-T.
Disassembly and cleaning	There are no components available to operators inside. Do not remove the protective cover. Maintenance must be carried out by qualified personnel.
Service environment	This device should be used indoors in a clean and dry environment with ambient temperature from 0°C to 40°C. Do not use this device in explosive, dusty or humid air.

Do not operate in humid environment	Do not use this device in a humid environment to avoid the risk of internal short circuit or electric shock.
Do not operate in flammable and explosive environment	Do not use this device in a flammable and explosive environment to avoid product damage or personal injury.
Caution	
Abnormality	If this device may be faulty, please contact the authorized maintenance personnel of UNI-T for testing. Any maintenance, adjustment or parts replacement must be done by the relevant personnel of UNI-T.
Cooling	Do not block the ventilation holes at the side and back of this device; Do not allow any external objects to enter this device via ventilation holes; Please ensure adequate ventilation, and leave a gap of at least 15 cm on both sides, front and back of this device.
Safe transportation	Please transport this device safely to prevent it from sliding, which may damage the buttons, knobs or interfaces on the instrument panel.
Proper ventilation	Poor ventilation will cause the device temperature to rise, thus causing damage to this device. Please keep proper ventilation during use, and regularly check the vents and fans.
Keep clean and dry	Please take actions to avoid dust or moisture in the air affecting the performance of this device. Please keep the product surface clean and dry.
Note	
Calibration	The recommended calibration period is one year. Calibration should only be carried out by qualified personnel.

Environmental Requirements

This instrument is suitable for the following environment:

- Indoor use
- Pollution degree 2
- Operating: altitude lower than 3000 meters; non-operating: altitude lower than 15000 meters
- Unless otherwise specified, operating temperature is 0 to +40°C; storage temperature is -20 to +60°C

- Operating: humidity temperature below to +35°C, ≤90% relative humidity; non-operating, humidity temperature +35°C to +40°C, ≤60% relative humidity

There are ventilation opening on the rear panel and side panel of the instrument. So please keep the air flowing through the vents of the instrument housing. To prevent excessive dust from blocking the vents, please clean the instrument housing regularly. The housing is not waterproof, please disconnect the power supply first and then wipe the housing with a dry cloth or a slightly moistened soft cloth.

Connecting Power Supply

The specification of input AC power

Voltage Range	Frequency
100V ~ 240VACrms (fluctuant: ±10%)	50/60Hz

Please use the attached power cable to connect to the power port.

Connecting to service cable

This instrument is a Class I safety product. The supplied power lead has good performance in terms of case ground. This spectrum analyzer is equipped with a three-prong power cable that meets international safety standards. It provides good case grounding performance for the specification of your country or region.

Please install AC power cable as follows.

- Ensure the power cable is in a good condition.
- Leave enough space for connecting the power cord.
- Plug the attached three-prong power cable into a well-grounded power socket.

Electrostatic Protection

Electrostatic discharge may cause damage to component. Components can be damaged invisibly by electrostatic discharge during transportation, storage and use.

The following measure can reduce the damage of electrostatic discharge.

- Testing in anti-static area as far as possible.
- Before connecting the power cable to the instrument, inner and outer conductors of the instrument should be briefly grounded to discharge static electricity.
- Ensure all the instruments are properly grounded to prevent the accumulation of static.

File Format

Key

“Key character (bold) + textbox” indicates function key on the front panel, such as **Utility** means the function key “Utility”.

Menu

“Menu character (bold)” indicates one menu, such as “**Setting**” means the setting menu on touch screen.

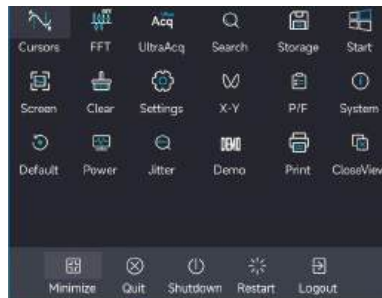

Operation Step

“>” indicates next operation, such as **Utility**>System, press the “Utility” key on the front panel, and then press the system key.

Connector

In this manual, it is common to use square brackets + text (bold) to indicate a connector on the front or rear panel, such as **[TRIG OUT]**.

Rotary Knob

In this manual, it is common to use rotary knob name to indicate a rotary knob on the front panel, such as “Scale” (vertical).

MSO8000HD Series Mixed Signal Oscilloscope

MSO8000HD series is the brand new mixed signal oscilloscope launched by UNI-T. The bandwidth up to 8GHz and sampling rate up to 20GSa/s, which has obvious advantages in high-speed signal analysis. MSO8000HD has unique UltraAcq® technology, it raises the wave capture rate to 300,000wfms/s; 1,000,000wfms/s on Sequence mode. combined with an ultra-long storage depth of 1Gpts, dramatically improves the ability to capture anomalous signals, as well as the ability to measure and analyze waveform details.

MSO8000HD supports multiple trigger decoding and has advanced measurement analysis, such as sequential mode, histogram, power analysis, jitter analysis, eye diagram analysis and template measurement. There are 52 kinds of parameters for automatic measurement, which greatly meets the measurement needs of engineers. This oscilloscope is equipped with Win10 64-bit operating system, providing users with a stable and expandable system platform. Adopting 15.6-inch high-definition capacitive touch screen, supporting multi-window split-screen display and multiple gesture touch control, it can be widely used in communication, aerospace, education and many other industries and fields.



MSO8000HD series includes the following model.

Model	Channels	bandwidth	Logic analyzer	AWG	Power analysis	Jitter analysis	Eye diagram
MSO8804HD	4	8GHz	○	○		○	○
MSO8504HD	4	5GHz	○	○	○	○	○

○ indicates option

Note: Only the MSO8504HD model supports DC1MΩ and AC1MΩ, which will not be further elaborated in the following text.

Main Features

- Analog channel bandwidth: up to 8G (8G/5GHz)
- Maximum sampling rate: 20GSa/s
- Maximum storage depth: 2Gpts (standard configuration)
- Wave capture rate: $\geq 300,000$ wfms/s(UltraAcq[®] mode); 1,000,000 wfms/s(Sequence mode)
- Multiple trigger types: edge, pulse width, slope, video, code pattern, timeout, runt, setup & hold, delay, duration, Nth-edge, zone
- 11 kinds of serial protocol analysis: RS232/422/485/UART, I²C, SPI, CAN, CAN-FD, LIN, FlexRay, SENT, MIL-STD-1553, ARINC 429, AudioBus (I²S/LJ/RJ/TDM)
- Integrate multiple functions into one, which is digital oscilloscope, logic analyzer, frequency spectrum analyzer, function/arbitrary waveform generator, digital voltmeter, frequency meter and protocol analyzer
- 52 kinds of parameter measurement, it supports histogram, trace and tendency chart
- Multiple advanced measurement analysis function: power analysis (option), jitter & eye diagram (option), template test and histogram, consistency Analysis (Option), histogram, search navigation
- Equipped with Win10 64-bit operating system, providing 15.6 inch high-definition capacitive touch screen for various kinds of gesture operation of clicking, sliding, zoom out and dragging
- Built-in WebServer can access the instrument and observe the measurement on browser, supporting two styles of layout and operation of PC/smartphone, easy to realize cross-platform access
- SCPI (Standard Command for Programmable Instrument)
- Various interfaces: USB Host & Device, LAN, HDMI, AUX In/Out, 10MHz Ref In/Out
- 8-channel waveform operation, built-in frequency spectrum analysis and peak search function, supporting Matlab embedded programming and data presentation, and support enhanced resolution up to 3bits
- Built-in dual channel (with equivalent performance) function/arbitrary waveform generator with 60MHz
- Built-in 16-channel logic analyzer: sampling rate 1.25GSa/s, storage depth 125Mpts

1. Quick Guide

- [General Inspection](#)
- [Before Use](#)
- [External Dimension](#)
- [Front Panel](#)
- [Rear Panel](#)
- [Operation Panel](#)
- [User Interface](#)
- [Touch Screen](#)
- [Virtual Keyboard](#)
- [Numeric Keyboard](#)

This chapter is to introduce on using the MSO8000HD series oscilloscope for the first time, the front and rear panels, the user interface, as well as touch screen function.

1.1 General Inspection

It is recommended to inspect the instrument follow the steps below before using the MSO8000HD series oscilloscope for the first time.

(1) Check for Damages caused by Transport

If the packaging carton or the foam plastic cushions are severely damaged, please contact the UNI-T distributor of this product immediately.

(2) Check Attachment

Please check appendix for the list of accessories. If any of the accessories are missing or damaged, please contact UNI-T or local distributors of this product.

(3) Machine Inspection

If the instrument appears to be damaged, not working properly, or has failed the functionality

test, please contact UNI-T or local distributors of this product.

If the equipment is damaged due to shipping, please keep the packaging and notify both the transportation department and UNI-T distributors, UNI-T will arrange maintenance or replacement.

1.2 Before Use

To perform a quick verification of the instrument's normal operations, please follow the steps below.

1. Connecting to the Power Supply

The power supply voltage range is from 100VAC to 240VAC, the frequency range is 50Hz to 60Hz. Use the assembled power line or other power line that meets the local country standards to connect the oscilloscope. When the power switch  on the rear panel is not opened, the power soft indicator in the left bottom on the rear panel is extinguished, which indicates this soft switch key is no-effect. When the power switch on the rear panel is opened, the power soft indicator in the left bottom on the rear panel is illuminated with orange, and then press the soft switch key to enable the oscilloscope.

2. Boot Check

Press the soft power key  and the indicator should change from orange to blue. The oscilloscope will show a boot animation, and then enter the normal interface.

3. Connecting Probe

Use BNC of the port to connect to BNC of C1 of the oscilloscope. Connecting the probe to the "probe compensation signal connection clip" (as shown in the following figure) and connecting the ground alligator clip to the "ground terminal" under the "probe compensation signal connection clip". The output of probe compensation signal connection clip is the amplitude about 3Vpp and the frequency defaults to 1kHz.

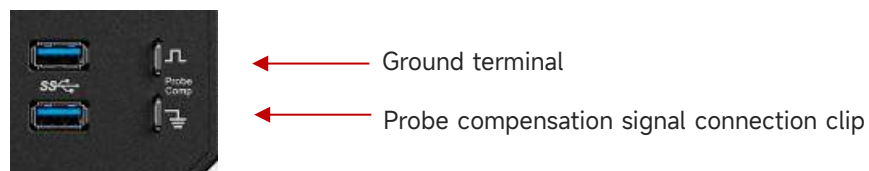

Figure Probe Compensation Signal Connection Clip and Ground Terminal

4. Function Check

Press the **Autoset** key, a 3Vpp, 1kHz square wave should appear on the screen. Repeat step 3 to check all channels. If the actual displayed square wave shape does not match the above figure, please perform the next step "Probe Compensation".

5. Probe Compensation

When the probe is connected to any input channel for the first time, this step might be adjusted to match the probe and the input channel. Probes that are not compensated may lead to measurement errors or mistake. Please follow the following steps.

(1) Set the attenuation coefficient in the probe menu to 10x and the switch of the probe at 10x, and connecting the probe of the oscilloscope to C1. If use the probe's hook head, make sure it stably touch to the probe.

(2) Connecting the probe to the "probe compensation signal connection clip" and connecting the ground alligator clip to the "ground terminal" under the "probe compensation signal connection clip". Open C1 and press the **Autoset** key.

View the displayed waveform, as shown in the following figure.

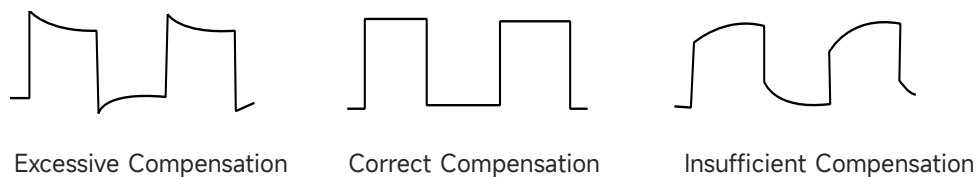
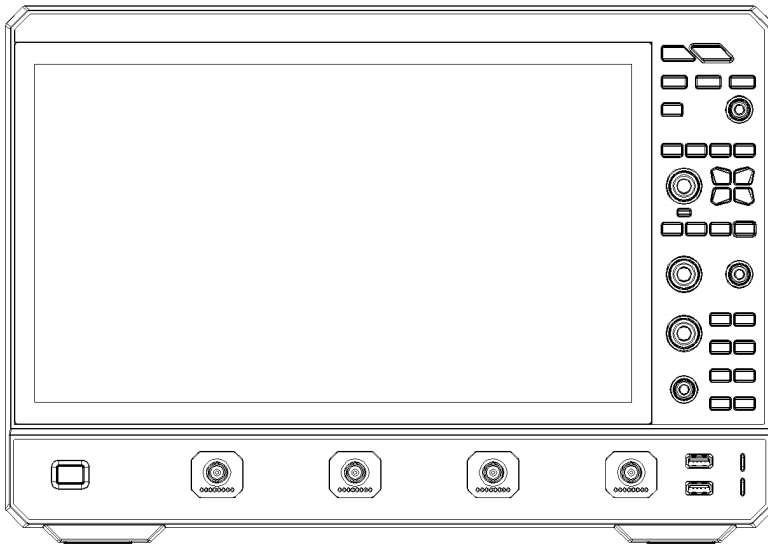

Figure Compensating Calibration of Probe

If the displayed waveform is look like the above "Insufficient Compensation" or "Excessive Compensation", use a non-metallic screwdriver to adjust the probe's variable capacitance until the display matches the "Correct compensation" waveform.

Warning: To avoid electric shock when using the probe to measure high voltage, please ensure that the probe insulation is in good condition and avoid physical contact with any metallic part of the probe.

1.3 External Dimension



Front View

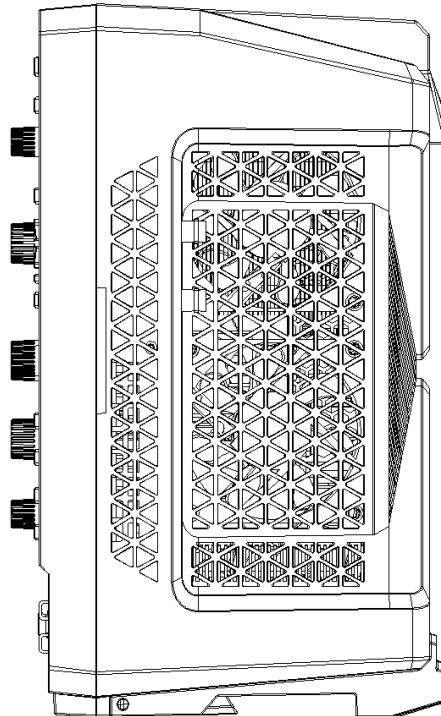

Side View

1.4 Front Panel



Figure Front Panel

Table 1 Function Key on Front Panel

No.	Description	No.	Description
1	Display area	8	Vertical control knob
2	Run/Stop key, Autoset key	9	Analog channel key
3	Trigger control area (Trigger)	10	Math, Ref, Digital, Bus key
4	Trigger level rotary knob	11	Probe compensation connection clip and ground terminal
5	Function control area (Function)	12	USB Host port
6	Multi-function rotary knob	13	Digital channel input port
7	Horizontal control knob	14	Power soft key

1.5 Rear Panel



Figure Rear Panel

Table 2 Interface on Rear Panel

No.	Description	No.	Description
1	Arbitrary waveform generator output port	9	Power input and switch
2	Digital channel input port	10	Ground terminal
3	Safety lock	11	external trigger input port
4	USB-TypeC port	12	AUX Out port
5	HDMI port	13	AUX In port
6	LAN port	14	10MHz Ref Out port
7	USB Host port	15	10MHz Ref In port
8	USB Device port		

1. Function/arbitrary waveform generator output interface
2. Digital channel access terminal
3. Safety Lock: this port (sold separately) is used to lock the oscilloscope at fixed position
4. USB-TypeC port

5. HDMI: high definition multimedia port
6. LAN: use this port to connect the oscilloscope to local area network for remote control
7. USB Host: used to connect a USB-compatible storage device to the oscilloscope. By connecting the storage device, you can save or recall waveform files and setup files of the oscilloscope, as well as save data and screenshots. The system software of the oscilloscope can be upgrade locally through the USB Host port when there is an available update.
8. USB Device: USB Device 3.0 port, use this port to connect the oscilloscope to computer for communication..
9. Power switch: after the AC outlet is correctly connected to the power supply, turn on the power switch, the oscilloscope can be normally powered on, at this time, just press the "power soft switch" on the front panel to turn on the power (the oscilloscope's power supply requirements is 100~240V, 50~60Hz) .
10. Ground terminal: used to connect to ground to export static electricity of device Safety Lock: this port (sold separately) is used to lock the oscilloscope at fixed position
11. External trigger channel access terminal
12. Aux Out: 1. Trigger synchronous output; 2. Pass the measured results; 3.AWG trigger output
13. Aux In: 1. Trigger synchronous input; 2. AWG external trigger input
14. 10MHz Ref Out: BNC connector on the rear panel, it can output its own 10MHz reference clock and provide it to other external instruments for inter-instrument clock synchronization.
15. 10MHz Ref In: provide the reference clock of sampling for the oscilloscope

1.6 Operation Panel



(1) Vertical Control Area

- **1** , **2** , **3** , **4** : Analog channel setting key respectively represents C1, C2, C3 and C4. Four channel's tab are identified by different colors and it also corresponding to the colors of waveforms on the screen and the channel input connectors. Press any keys to turn on the related channel menu (activate or disable the channel).
- **Math**: Press this key to open the mathematical operation for basic

arithmetical operation, such as FFT, digital filter and advanced operation.

- **Ref**: Loading the reference waveform from 'local or USB", it compare the measured waveform with the reference waveform.
- **Digital**: Press this key to turn on the digital channel, it can set the channel and threshold level.
- **Bus**: Press this key to pop out the bus state window, it can select the protocol type, such as RS232, I²C.
- Vertical "Position": Vertical shift rotary knob can move the vertical position of the current channel waveform. Press this knob to move the channel position back to the vertical midpoint.
- Vertical **Scale**: Vertical scale rotary knob can adjust the vertical position of the current channel waveform. Turn clockwise to decrease the scale, turn counterclockwise to increase the scale. The amplitude of waveform will increase or decrease with the adjustment and the scale at the bottom of screen will change in real-time.

(2) Horizontal Control Area



- Horizontal **Position**: Horizontal shift rotary knob can move the trigger point to left or right side that relative to the center of the screen. During the adjustment, all channel's waveform will move to left or right side and the horizontal shift value on the top of the screen will change in real-time. Press this rotary knob to move the current position back to the horizontal midpoint.
- Horizontal **Scale**: Horizontal time base rotary knob can adjust time base scale of all channel. During the adjustment, user can see the waveform is compressed or extend in horizontal direction on the screen and the time base scale will display on the top of the screen, the time base step is 1-2-5.

(3) Trigger Control Area



- **Single**: Press this key to set the trigger mode of the oscilloscope to "Single" and the indicator turn to green. It will execute one trigger when receive the signal meets the trigger condition. Press the Run/Stop key and the indicator turn to red, it indicates enter the "Stop" state and it will not refresh even if the signal meets the trigger condition.
- **Normal**: Press this key to set the trigger mode of the oscilloscope to "Normal" and the indicator turn to white. It will execute one trigger when receive the signal meets the trigger

condition. The waveform will stay at the screen and will not refresh until next trigger

- **Auto**: Press this key to set the trigger mode of the oscilloscope to “Auto” and the indicator turn to white. The waveform will continue to refresh regardless of whether the trigger condition is met, and the waveform will be stable display when receive the signal meets the trigger condition.
- **Level Rotary Knob**: This rotary knob can change trigger level, the level cursor will change with the movement.
- **Force**: Force trigger key
- **Menu**: Trigger menu key can enter the trigger setting menu. MSO8000HD supports multiple trigger types.

(4) Automatic Setting



- Press this key, the oscilloscope will automatically adjust the vertical scale, scanning time base and trigger mode to display the most suitable waveform according to the input signal.

Caution: When use the waveform automatic setting, if the measured signal is sine wave, it requires its frequency cannot less than 20Hz and the amplitude should at the range of 20mVpp~120Vpp. Otherwise, the waveform automatic setting may be invalid.

(5) Run/Stop



- Press this key to set the operating state to “RUN” or “STOP”.
In the “Run” state, the key is illuminated in green.
In the “Stop” state, the key is illuminated in red.

(6) Functional Area

- **Multifunction Rotary Knob**: The cursor area can be moved or located by pressing this key.
- **Cursors**: Press this key to turn on/off the cursor. The cursor type, synchronous movement, cursor position can be set in the cursor menu. Time and voltage parameter of the cursor measurement can be passed by manual.
- **Meas**: Press this key to directly turn on the parameter measurement. The measurement parameter, turn on/off indicator can be set in the parameter menu. A total of 48 measurement parameters.
- **Quick Meas**: Press this key to directly turn on the parameter snapshot, a total of 35

measurement parameters.

- **UltraAcq**: Press this key to set the acquisition mode to fast sampling or normal sampling.
- **Start menu**: Press this  key to pop out the start menu, turn on the cursor, Lissajous, P/F test, power analysis, jitter analysis and eye diagram.



- **Custom buttons**: Support customizing the function of this button, enabling quick cursor, setting, and other operations.
- **Screenshot**: Press this  key to capture the screen and save to the specified file folder.
- **Clear**: Press this key to delete the old waveform which including waveform measurement parameter. If the oscilloscope is in the “Run” state, then it continue to display the new waveform.
- **Push to Fine**: Press this key to activate the fine adjustment function for cursor position and numerical input.
- **DVM**: Press this key to directly open the voltmeter measurement, it can set three modes of DC, AC RMS and DC+AC RMS.
- **Gen**: Press this key to open dual channel function/arbitrary
- **Touch Lock**: Press this key to lock the touch function.
- **Default**: Press this key to restore the oscilloscope to the factory setting.

1.7 User's Interface

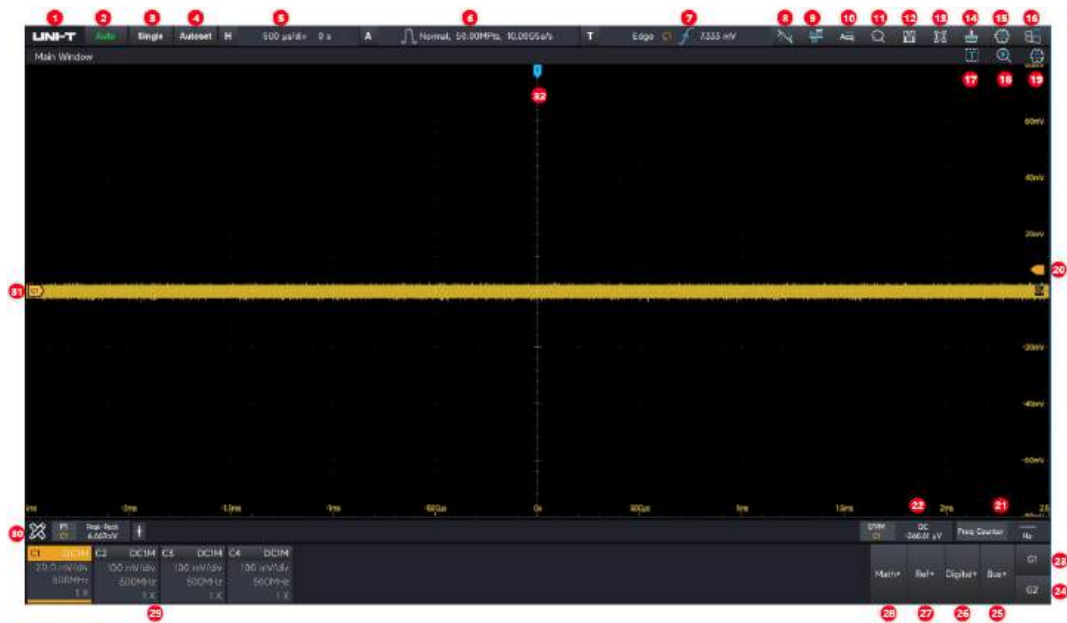





Table 3 Icon in User's Interface

No.	Description	No.	Description
1	UNI-T logo	17	Zone draw
2	Trigger state icon	18	Zoom
3	Single trigger	19	Window display and setting
4	Autoset	20	Trigger level cursor
5	Horizontal scale and delay	21	Frequency meter
6	Acquisition mode, storage depth and sampling rate	22	Digital voltmeter
7	Trigger information	23/24	Function/Arbitrary waveform generator
8	Cursor measurement	25	Protocol analyzer
9	FFT	26	Logic analyzer
10	UltraAcq® mode	27	Reference waveform
11	Search and Navigation	28	Mathematical operation
12	Save	29	Channel state icon
13	Screenshot	30	Measurement menu
14	Clean	31	Analog channel cursor and waveform



15	System setting	32	Trigger position cursor
16	Start menu		



1. Company logo: UNI-T
2. Trigger Status : Including Triggered、Auto、Ready、Stop、Roll。
3. Single: Set the trigger mode of the oscilloscope to "Single", and the green light of this key will be on. When the signal that meets the trigger condition arrives, a trigger is executed once, and the red light of the "Run/Stop" button is on and enters the "Stop" state. Even if there is a signal that meets the trigger condition, it will no longer be refreshed.
4. Autoset: Touch this icon, and the oscilloscope will automatically adjust the vertical scale coefficient, scan time base, and trigger mode according to the input signal until the most appropriate waveform is displayed.



Note: When using the automatic waveform setting function, if the measured signal is a sine wave, its frequency is required to be no less than 20Hz and the amplitude is within 10mVpp to 80Vpp; if this parameter condition is not met, the automatic waveform setting function may not be accurate.

5. Horizontal scale and delay: Touch the time base gear, and the "Time Base Setting" pop-up window can pop up. The time base gear represents the time represented by one grid on the horizontal axis of the screen waveform display area. You can click  and  to adjust the current horizontal scale, and the scale change is in a 1-2-5 step. You can also use the "Scale" knob in the horizontal control area on the front panel of the oscilloscope to change this parameter. The delay indicates the distance between the current waveform trigger point position and the horizontal center scale. A positive value indicates that the trigger point is shifted to the left, and a negative value indicates that the trigger point is shifted to the right. You can click  and  on the time base setting pop-up window to set the current delay time. You can also click the delay value to pop up the numeric keypad and enter the delay time through the numeric keypad. You can adjust the "Position" knob in the horizontal control area on the front panel of the oscilloscope to change this parameter. Clicking Delay Reset to Zero can bring the trigger point back to the center position, and pressing the "Position" knob can bring the horizontal displacement value back to 0.
6. Acquisition mode, memory depth and sample rate: Display the current acquisition mode of the oscilloscope (normal, peak detection, high resolution, average) as well as the current memory depth and real-time sampling rate of the oscilloscope.
7. Trigger information: Display the current trigger source, trigger type, trigger level and other

trigger information.

- Trigger source: C1 ~ C4、EXT、EXT5、AC、D0-D15, The color display is consistent with the channel color.
 - Trigger type: Edge, Pulse width, Video, Slope, Runt pulse、Delay、Timeout、Duration、Setup & Hold、Nth edge、Pattern and Serial etc.
 - Level: Display the value of the current trigger level, corresponding to the ones  on the right side of the screen (the trigger level color of each channel corresponds to the channel color). You can click on the  and  on the trigger setting pop-up window to adjust the threshold level, or click on the threshold level value to pop up the numeric keyboard. You can input the threshold level value through the numeric keyboard. This parameter can also be changed by the "Level" knob in the trigger control area on the front panel of the oscilloscope.
8. Cursor: Touching this icon can pop up the cursor setting menu to perform operations such as turning the cursor on/off, selecting the cursor type, setting synchronous movement, adjusting the cursor position, and setting the cursor measurement unit.
 9. FFT: Touching can open an independent Math window with the operation type of FFT.
 10. UltraAcq® mode: Clicking can open UltraAcq (Ultra Acquisition Mode) to increase the waveform capture rate to 600,000wfms/s.
 11. Search and Navigation: Opening it enables waveform search and navigation, and supports edge /pulse width search methods.
 12. Save: Click to enter the storage interface pop-up window, and the screen information can be saved.
 - Save waveform: .bin/.txt/.mat/.xlsx/.csv/.tsv/.dat etc.
 - Screenshot: The screen area / grid area can be saved. Saved colors: standard / black and white / inverse color. Saved picture types: .bmp /.tiff /.gif /.png /.jpeg.
 - Save system settings: The current system setting information can be saved as a .set file. Users can read the saved .set file to restore to the setting status saved last time.
 13. Quick screenshot: perform a quick screenshot according to the setting information of the screenshot saving settings, and prompt the successful saving information.
 14. Clear: Clear the old waveforms displayed on the screen, including the measurement parameters.
 15. System setting: Click to pop up the "Settings" function pop-up window, where you can adjust the brightness, perform automatic settings and corrections, configure communication, auxiliary input and output, and other settings, etc.

16. Strat Meau: Click to pop up the Start Menu pop-up window, including cursor measurement, FFT, Lissajous, Limit and mask test, power analysis, jitter analysis and eye diagram, etc.
17. Zone draw: The drawable area is used for area histogram statistics and zone trigger.
18. Zoom: It can be used to horizontally zoom in on a section of the waveform to view image details. Click  to open the view expansion and click  to close the view expansion.
19. Main window display settings: Click to open the window display settings, and the afterglow, horizontal/vertical marker position, grid style, grid brightness, waveform style, waveform brightness, etc. can be adjusted.
20. Trigger level: It shows the current channel trigger level position, and the trigger level cursor color corresponds to the channel color.
21. Frequency counter : 8-digital high-precision hardware frequency counter.
22. DVM: 4-digital DC/AC RMS/DC + AC RMS voltage measurement.
23. AWG: Click G1 to open Channel 1 of the function arbitrary waveform generator, and click G2 to open Channel 2 of the function arbitrary waveform generator.
24. Same as 23
25. Protocol Analyzer: Click Bus + to open the software function of the protocol analyzer, which supports 11 protocol analysis functions.
26. Logic analyzer: Click Logic + to open the logic analyzer software. It can connect 16 digital channels for analysis and measurement.
27. REF : Click Ref + to add the reference waveform to the oscilloscope for analysis and measurement. It supports two formats of reference waveforms: .bin and.csv.
28. Math: Click Math + to open the mathematical operation function. It supports enhanced FFT, basic operations, filter, advanced function editing, Matlab embedded programming operations and rendering, enhanced resolution, etc., and can support 8 mathematical waveforms simultaneously.
29. Channel status label: Displays channel activation status, channel coupling, bandwidth limit, vertical scale, probe attenuation coefficient, and inversion.
 - Channel activation status: the channel menu is lit to indicate activation, and gray to indicate deactivation.
 - Channel coupling: DC1MΩ、AC1MΩ、DC50Ω、Ground.
 - Bandwidth limit: Full bandwidth is displayed as "8GHz" or "4GHz", and when the bandwidth limit is enabled, the current bandwidth limit is displayed.
 - Vertical scale: It shows the vertical scale of the analog channel. This parameter can be

changed by adjusting the "Scale" knob in the vertical control area on the front panel of the oscilloscope or by clicking the channel status label to pop up the analog channel pop-up window, and adjusting  and .

- probe attenuation coefficient: The probe attenuation coefficient of the analog channel is displayed, including 1X,5X, 10X, 100X, and custom.
- Inversion: When inversion is enabled, the channel status box displays "↓", and when inversion is disabled, "↓" is not displayed.
- Touching the color label of the analog channel can open the channel. Double-clicking/sliding down can close the analog channel. Sliding down on other channels can close the channel.

30. Measurement bar menu: Click to pop up the measurement bar menu, which can enable digital voltmeter measurement, frequency meter measurement, open parameter snapshot, set measurement threshold, conduct measurement statistics, add parameter measurement, etc.

1.8 Touch Screen

- Tap
- Squeeze
- Drag

MSO8000HD series provides 15.6 inch super capacitive touch screen, multiple point touch control and gesture control. MSO8000HD has easily operating system with flexible and high sensitive touch screen features for great waveform display and excellent user experience.

Touch control function includes tap, squeeze and drag.

Hint: The menu displayed on the screen of the oscilloscope can all use the touch control function.

Tap

Use one finger to slightly tap icon or word on the screen as shown in the following figure.

Tap gesture can use for:

- Tap the menu displayed on the screen and then to setup
- Tap the function guide icon on the right corner of the screen to enable it
- Tap to pop out numeric keypad to set parameter
- Tap virtual keyboard to set tab and file name

- Tap message to pop out close button on the right corner to close it
- Tap other window displayed on the screen to setup



Figure Tap Gesture

Squeeze

Squeeze two fingers together or separate. Squeeze gesture can zoom out or zoom in the waveform. If the waveform need to zoom out, squeeze two finger together and then slide away; If the waveform need to zoom out, separate two fingers and then squeeze two fingers together as shown in the following figure.

Squeeze gesture can use for:

- Adjusting horizontal time base of waveform by squeezing on the horizontal direction
- Adjusting vertical scale of waveform by squeezing on the vertical direction

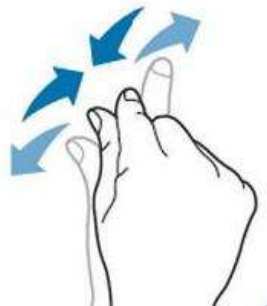

Figure Squeeze Gesture

Drag

Use one finger to press and drag the selected item to the aimed position as shown in the following figure.

Drag gesture can use for:

- Drag waveform to change waveform displacement or offset
- Drag window control to change window position
- Drag cursor to change cursor position

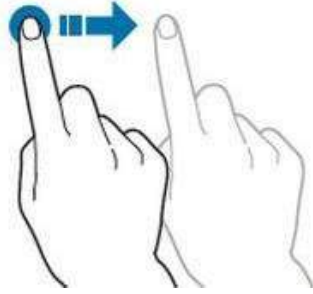
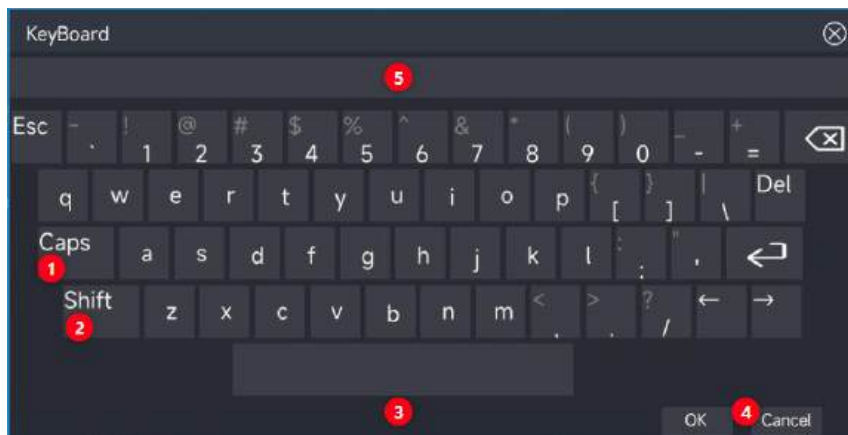

Figure Drag Gesture

1.9 Virtual Keyboard

MSO8000HD supports the virtual keyboard, it mainly used to input enter or character (when rename the tab, clicking the tab to pop out the virtual keyboard to input). This section describes the layout and usage of virtual keyboard.



The virtual keyboard uses a traditional 26-key layout

(1)Caps key: Input the uppercase character.

When input the uppercase character, please observe the “Caps” key at first and then to switch capital or small letter. If the current state is selected and the tab is blue, then click the virtual keyboard to input the uppercase character. If the current state is not selected, please switch to the selected state and then click the virtual keyboard to input the uppercase character. All input will display at the “Input area” on the keyboard.

(2)Shift key: Many keys have multiple input characters . For example, when you want to enter the top character, please observe whether the “Shift” tab is selected. In this case, the virtual keyboard with multiple character input will switch the input character, and the other keys will be for uppercase character input. If the tab is not selected, please click the “Shift” tab to select and then click the virtual keyboard to input the top character.

(3)Space key: Used to insert a space character between character strings.

- (4) Confirm & Cancel key: Used to input or cancel the input the preset value of the keyboard on “input area” to the oscilloscope after the input is finished.
- (5) Input display area: Display the input character of virtual keyboard on “input area” for checking.

1.10 Numeric Keyboard

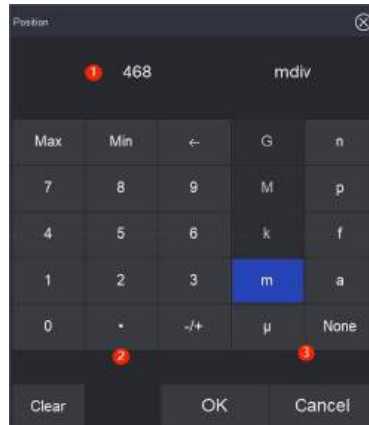

The numeric keyboard has a traditional 9-key layout for inputting value and unit. The unit format of numeric keyboard is related with function. For example, the default unit is “div” when the numeric keyboard is opened, it indicates the unit of the entered value is the number of grid displayed on the screen.

- (1) Input area: Display the input numeric value and unit by the numeric keyboard on the input area.
- (2) Input area of number: Traditional 9-key layout, “←” means retreat number. “-/+” means the positive/negative of numerical value. “Maximum” indicates the maximum input. “Minimum” means the minimum input.
- (3) Unit Input Area

2. Vertical System

- [Open/Activate/Close Analog Channel](#)
- [Channel Coupling](#)
- [Bandwidth Limit](#)
- [Vertical Scale](#)
- [Vertical Position](#)
- [Offset Voltage](#)
- [Unit](#)
- [Reversed Phase](#)
- [Tab](#)
- [Probe Multiplying Power](#)
- [Multi-channel Display](#)
- [Setting channel delay](#)

Caution: MSO8000HD provides 4 analog channel of C1 ~ C4, each channel

The setup method of the vertical system for each channel is exactly the same, and this chapter introduces the setting of the vertical channel using C1 as an example.

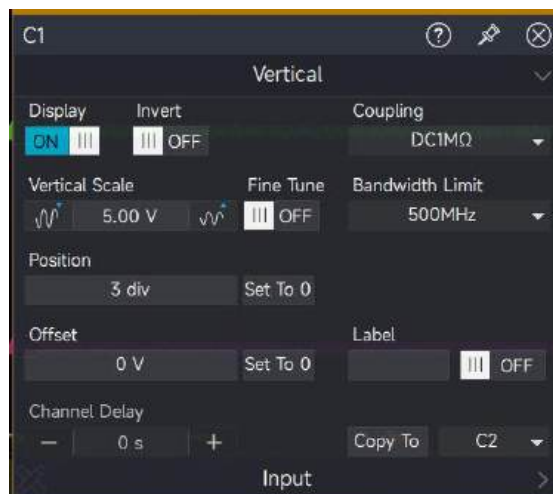

2.1 Open/Activate/Close Analog Channel

C1 ~ C4 analog channel contains three kinds of state, open, close and selected.



Selected State

Open but not Selected

Off State

Open: The analog channels are identified with a different color, and the colors of the waveforms on the screen is corresponding to the color of channel input connectors.

- Panel operation: When an analog channel is turned off, click any one of the channel key 1 , 2 , 3 , 4 to turn on the corresponding channel.
- Touch screen operation: When an analog channel displays grey, touch the grey block to turn on the corresponding channel.

OFF: Not display the waveform of the corresponding channel.

- Panel operation: Press any one of the channel that open and activated, press the corresponding channel key to turn off this channel (if this channel is not selected, click this channel key to select).
- Touch-control operation: Any one of the channel can be turned off by sliding down, no matter whether the channel is selected.

Selected: When multiple channels are turned on at the same time, only one channel can be selected (it must be turned on to be selected), and in the selected state, the channel's vertical scale, vertical shift and channel setting can be adjusted.

- Panel operation: Any one of channel that open but not selected, press the corresponding channel to select this channel. When any channel is selected, the next step can be performed on that channel.
- Touch-control operation: Using touch gesture to click the menu to select the corresponding channel.

2.2 Channel Coupling

The channel coupling can be set in the channel menu, it can select four coupling types of DC1M Ω , DC50 Ω , AC1M Ω and Ground.

C1	DC1M	C2	DC50	C3	AC1M	C4	Gnd
200 mV/div		200 mV/div		200 mV/div		200 mV/div	
500MHz		1GHz		500MHz		500MHz	
1 X		1 X		1 X		1 X	
DC1M Ω		DC50 Ω		AC1M Ω		Ground	

2.3 Bandwidth Limit

In the state of 1M Ω impedance, the bandwidth limitation can set be to full bandwidth or 20MHz. In the state of 50 Ω impedance, the bandwidth limitation can set be to full bandwidth, 4GHz, 500MHz or 20MHz.

If the soft key menu sets to 20MHz, the bandwidth limitation of oscilloscope will limit at 20MHz. High-frequency signals above 20MHz in an attenuation signal, which is often used to reduce high-frequency noise in a signal when observing low-frequency signals.



C1	DC50	C2	DC50	C3	DC1M	C4	DC1M
20.0 mV/div		100 mV/div		100 mV/div		100 mV/div	
4GHz		2GHz		500MHz		20MHz	
1 X		1 X		1 X		1 X	
4GHz		2GHz		500MHz		20MHz	

2.4 Vertical Scale

The vertical scale range of oscilloscope is 1M Ω : 1mV/div ~ 10V/div; 50 Ω : 1mV/div ~ 1V/div and step with 1-2-5.

Caution: “div” indicates the grid in the oscilloscope’s waveform display area. /div indicates each grid.

- Panel operation: The vertical scale can be set in the channel menu, rotating the “Scale” rotary knob in vertical control area to quickly switch the vertical scale.

- Touch-control operation: Using touch gesture to click the channel to pop out the channel menu, clicking  and  to adjust the vertical scale of oscilloscope. Using squeeze gesture to directly adjust the size of vertical scale and break the step limitation of 1-2-5.

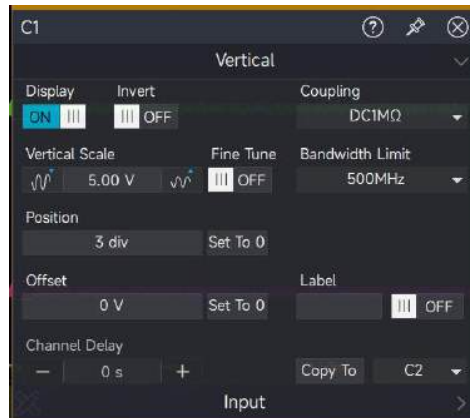

- Numeric keypad input: In the channel menu, clicking on the position value will pop up a numeric keypad window. You can enter the corresponding vertical scale value through the numeric keypad.

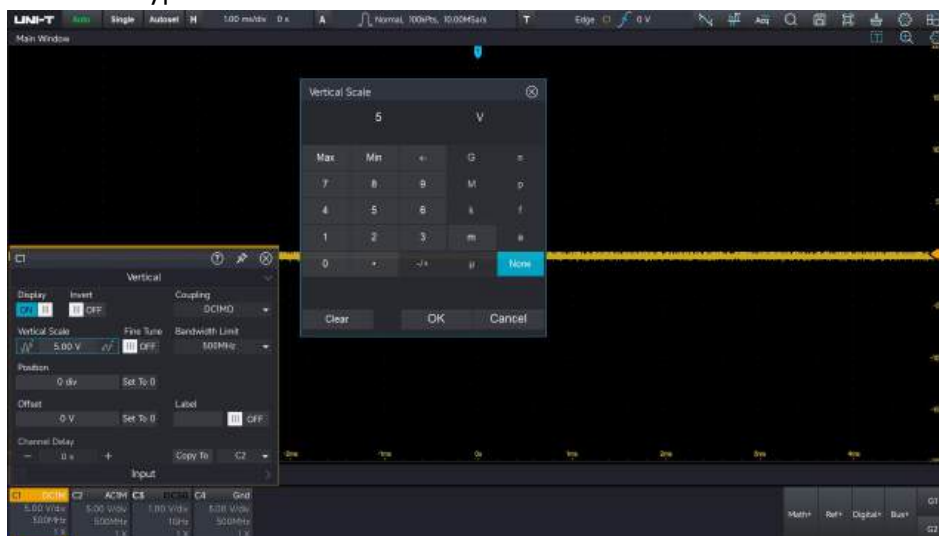

2.5 Vertical Position

The vertical position indicates the position of the current waveform on the screen, change the vertical position will not change the waveform voltage value. The vertical position of the current channel can adjust by the panel operation, touch-control operation and touch gesture.

- Panel operation: Rotating the “Position” rotary knob in vertical control area on the front panel to adjust the vertical position of the current channel’s waveform. Rotating to left side, the waveform goes down, rotating to right side, the waveform goes up. Press the “Position” rotary knob to move the waveform position back to the screen center.

Caution: Waveform go up/down cannot over the current vertical direction of 1.5div.

- Gesture operation: Select the waveform by gesture, sliding up or sliding down can change the waveform position.

Caution: Sliding up or sliding down cannot over the current vertical direction of 1.5div.

- Numeric keyboard: Click the numerical value of position to pop out the numeric keyboard window to input the vertical position. The positive value indicates move up, the negative value indicates move down.

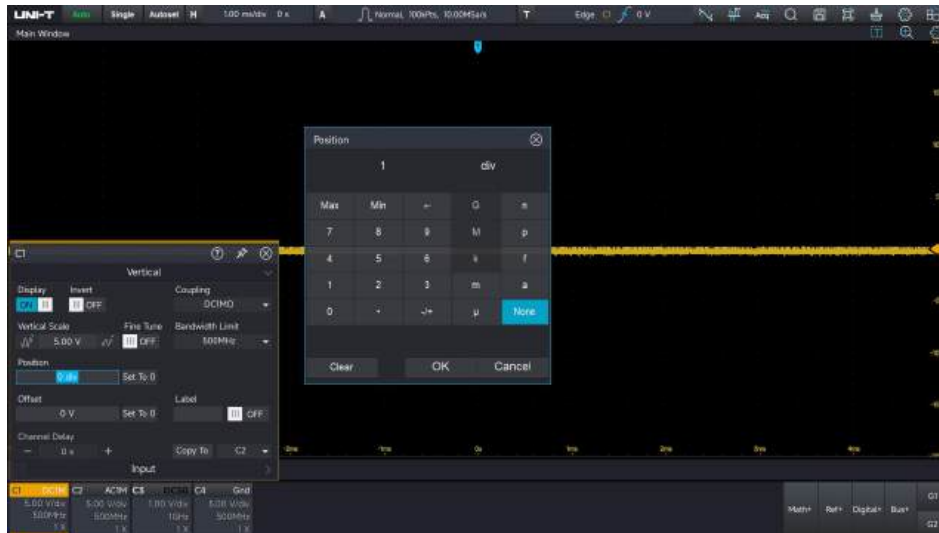

Caution: Input value cannot over the current vertical direction of 1.5div.

Set to 0: Click 0 tab in the channel menu, adjust the channel's waveform position to the screen center.

2.6 Offset Voltage

The offset voltage indicates the voltage offset of the current channel, it can be set by the numeric keyboard. The channel voltage will change with the setup and the waveform will also move with the vertical movement.

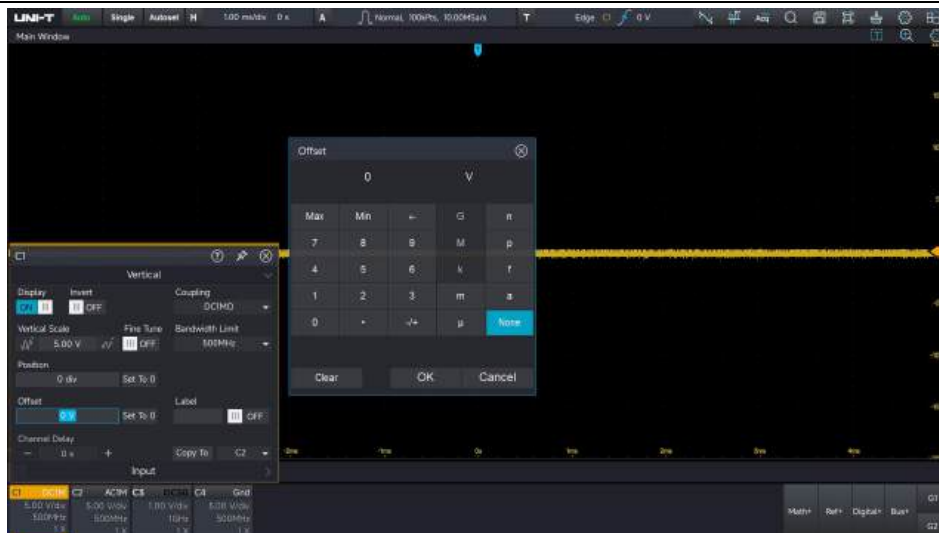

Set to 0: Click 0 tab next to the offset voltage, adjust the channel's offset voltage to 0mV.

2.7 Unit

The user can customize the vertical scale unit by the numeric keyboard. Set different units to cope with different measurement scenarios. For example, when using the current probe to measure current, the unit should be set to A/mA for easy observation.

2.8 Reversed Phase

The reversed phase can be set in the channel menu, when the reversed phase is enabled, the waveform voltage will be reversed and the reversed icon  will appear in the vertical state.

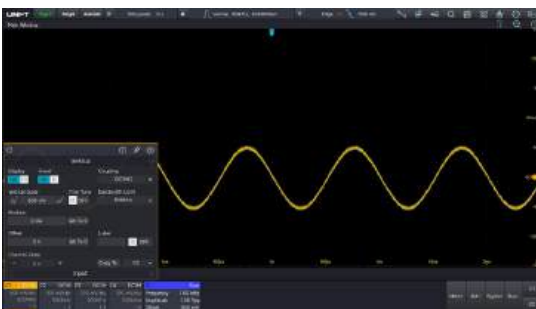

Reversed Phase ON

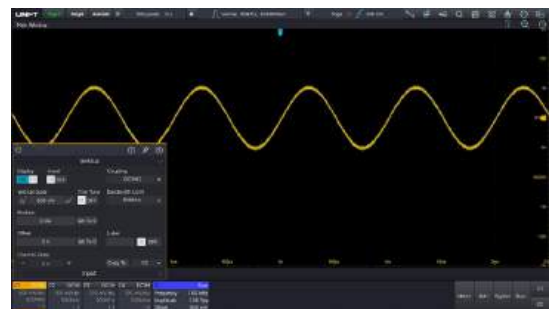

Reversed Phase OFF

2.9 Tab

Click the tab in the channel menu to pop out the soft keyboard, the input channel tab can be customized through the software keyboard for distinguishing the mark of channel's waveform when using. The input tab will display at the channel cursor on the left side of the screen.



2.10 Probe Multiplying Power

To match the probe attenuation coefficient setting, the probe attenuation coefficient needs to be set accordingly in the channel operation menu input. For example, if the probe attenuation coefficient is 10:1, which indicates the probe attenuates the measured signal to 10 times to input to the oscilloscope, so that the probe factor of the oscilloscope's channel menu should be set to $\times 10$. It indicates enlarge the input signal to 10 times to ensure that the measuring voltage of the oscilloscope is correct. The probe can be set to $\times 1$, $\times 5$, $\times 10$ and $\times 100$.

Caution: When the oscilloscope is plugged into a probe with a probe attenuation ratio detection pin (which has different resistors representing different attenuation ratios), the oscilloscope automatically recognizes the probe attenuation coefficient and sets the probe attenuation ratio to a value that matches it.

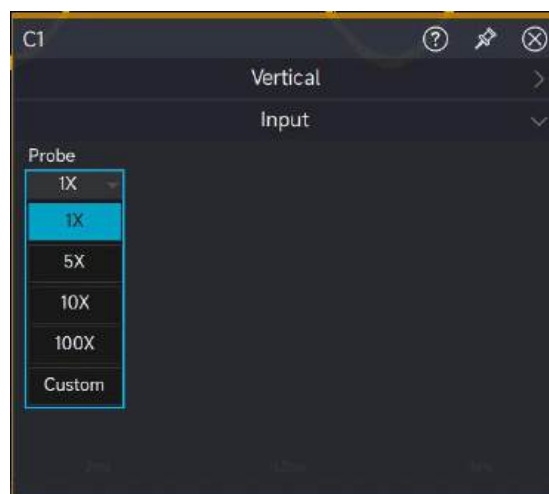

2.11 Spare Units

Open the alternate unit. Clicking on the unit will pop up a soft keyboard. You can custom - input the alternate unit through the soft keyboard, which is used to separately set the units of different types of input signals in various test scenarios. After modifying the unit, the units of the vertical scale, offset voltage in the channel status, and the units related to measurement will change accordingly.

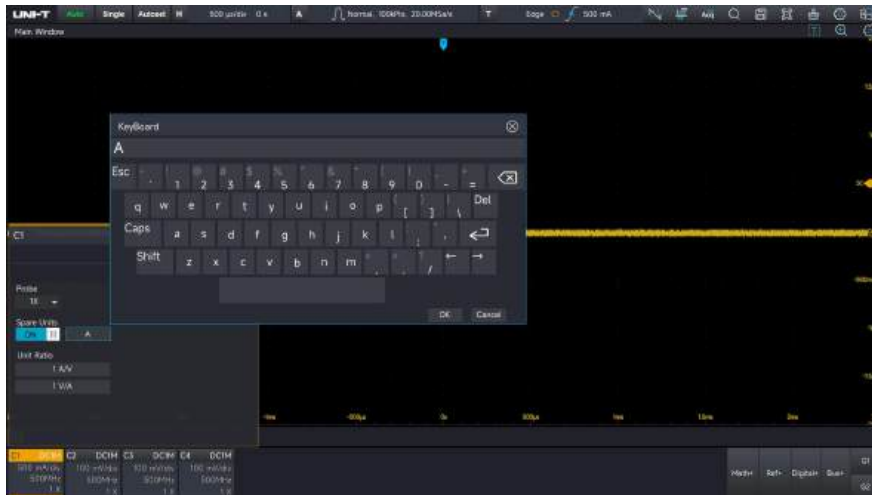

Click on the unit ratio and enter the corresponding unit conversion ratio through the numeric keypad.

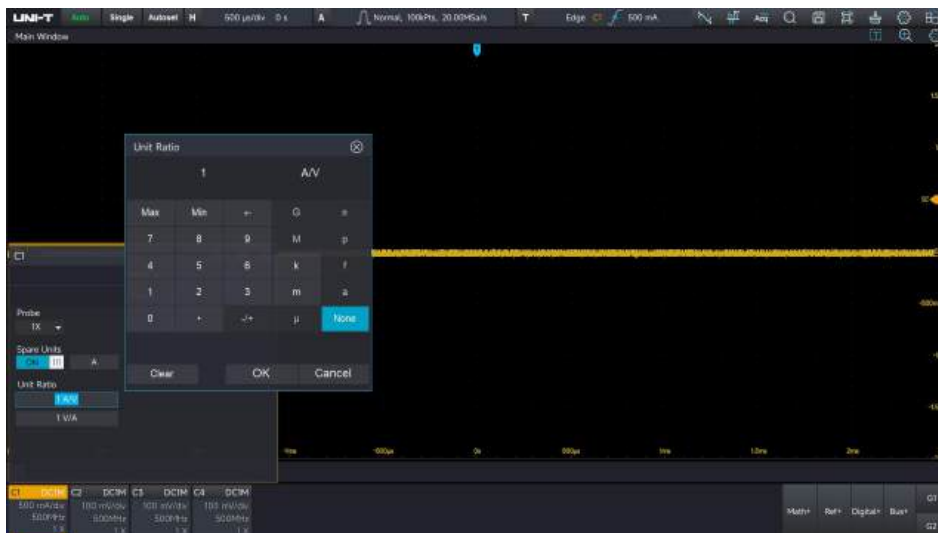

2.12 Setting channel delay

When conducting actual measurements using an oscilloscope, the transmission delay of the probe cable may introduce significant errors (zero offset). The MSO8000HD can ensure that the phases between channels are in the same state by setting the channel delay step. This is very

common in application scenarios that require high-precision measurements such as power supply analysis. Click the channel menu, and on the popped-up channel menu setting page, select the delay step (the minimum step is 100ps, and $\pm 800ps$ can be set).

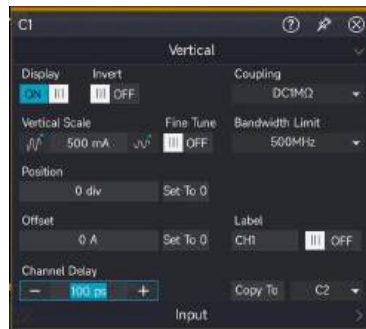

The channel delay calibration is only valid when the time base range is 50ns/div or lower:

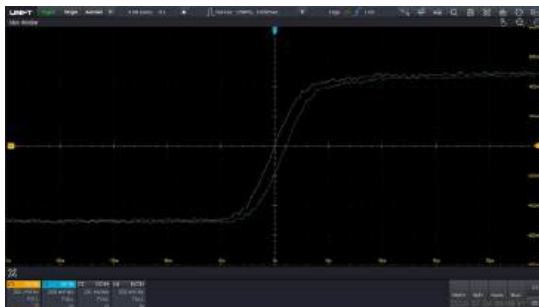

Before delay correction

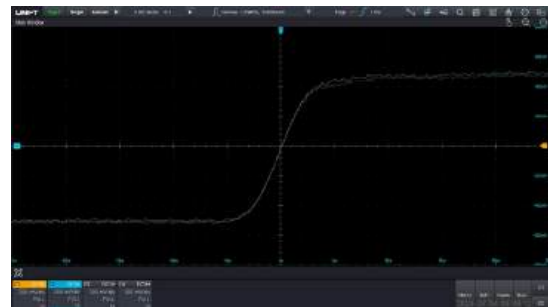

After delay correction

2.13 Channel Copy

When the same settings are required for multiple channels of an oscilloscope, you can directly use the channel copy function. With this function, you can copy the channel parameters such as coupling mode, bandwidth limit, and offset voltage that have been set for one channel to other channels with just one click.





3. Horizontal System

- [Horizontal Scale](#)
- [Horizontal Delay](#)
- [Roll Mode](#)

3.1 Horizontal Scale

The horizontal scale is also known as the horizontal time base, i.e., the time value represented by each scale in the horizontal direction of the screen, usually expressed as s/div. The horizontal scale has three adjusting method of panel operation, touch-control operation and gesture operation.

Panel operation: Adjusting the horizontal scale by the “Scale” rotary knob in horizontal control area, set the horizontal scale by step of 1-2-5. Clockwise rotating to decrease the scale, anticlockwise rotating to increase the scale. When adjusting the horizontal time base, the horizontal time base on top left of the screen will display the changing in real time.

Touch-control operation: Clicking the horizontal time base on top left of the screen to pop out the setup window, clicking  and  to adjust the current horizontal time base, it can also directly click the numeric value of horizontal scale to pop out the numeric keyboard to input the time base scale.



indicates the horizontal time base is increased.



indicates the horizontal time base is decreased.

Caution: The scale changes in 1-2-5 steps, and the input value does not change the stepping pattern.

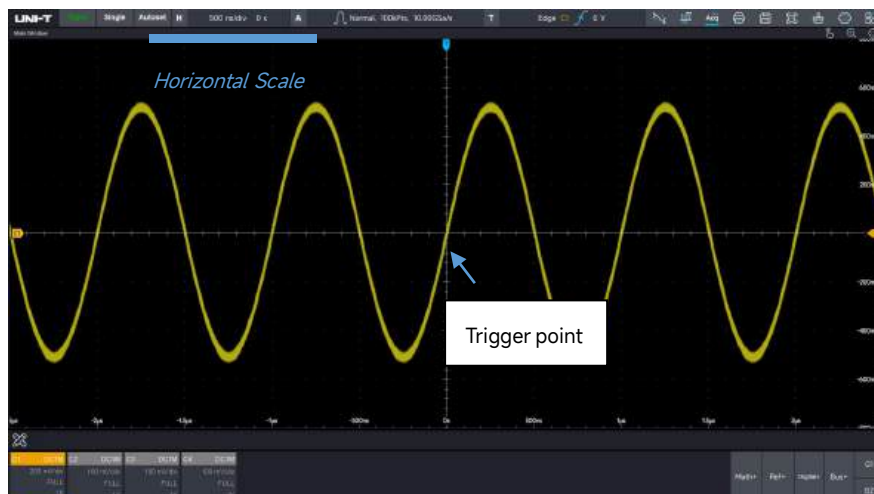



Gesture operation: When the channel is selected, adjusting the time base by squeeze gesture.

When changing the horizontal time base, the waveform will expand or compress accordingly with the position of the trigger point.

3.2 Horizontal Delay

The horizontal delay is also known as the horizontal shift, i.e., the trigger point moves left and right relative to the center of the screen. The horizontal shift has three adjusting method of panel operation, touch-control operation and gesture operation.

Panel operation: Adjusting the horizontal shift by the “Position” rotary knob in horizontal control area, clockwise rotating to move the waveform to left side, anticlockwise rotating to move the waveform to right side. When adjusting the horizontal delay, the horizontal delay on top left of the screen will display the changing in real time. Press the “Position” rotary knob to set the horizontal delay to zero.

Touch-control operation: Clicking the horizontal time base on top left of the screen to pop out the setup window, clicking  and  to adjust the current horizontal time base, it can also directly click the numeric value of horizontal delay to pop out the numeric keyboard to input the delay time. Clicking delay zeroing is to set the horizontal delay of current channel to zero.

Caution: The positive value indicates the horizontal delay moves to left side, the negative value indicates the horizontal delay moves to right side.



When changing the horizontal delay, the waveform will follow the trigger point move to left and right side.

Gesture operation: When the channel is selected, click the waveform by using touch gesture, sliding left/sliding right to change the waveform delay.

3.3 Roll Mode

When trigger mode is automatic state, adjusting the “Scale” rotary knob in horizontal control area, if the horizontal scale of the oscilloscope is lower than 50ms/div, the oscilloscope will enter ROLL mode.

The oscilloscope will continuously draw a voltage-time trend of the waveform on the screen. In the ROLL mode, the waveform is scrolled from right to left to refresh the display, and the latest waveform is drawn at the far right end of the screen.

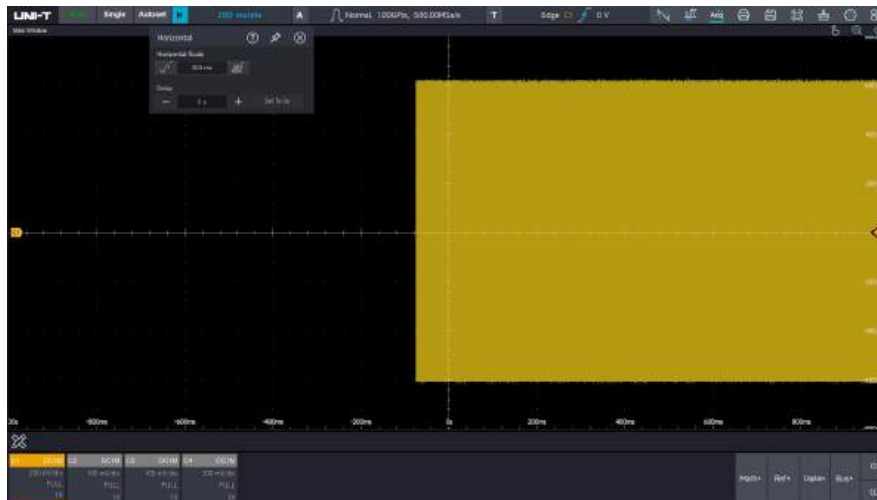

When apply the roll mode to observe low-frequency signal, it's recommend that set the “channel coupling” to “DC”.

4. Sampling System

- [Sampling Rate](#)
- [Acquisition Mode](#)
- [Storage Depth](#)
- [Sequence Mode](#)
- [ERES](#)

Sampling is the conversion of the signal from an analog input channel, through an analog-to-digital converter (ADC), into a discrete point.

4.1 Sampling Rate

(1) Sampling and Sampling Rate

Sampling indicates that the oscilloscope is take a sample from the input analog signal and convert the sample to digital data, and then gathering the digital data to waveform records. The waveform records will save in the storage memory.

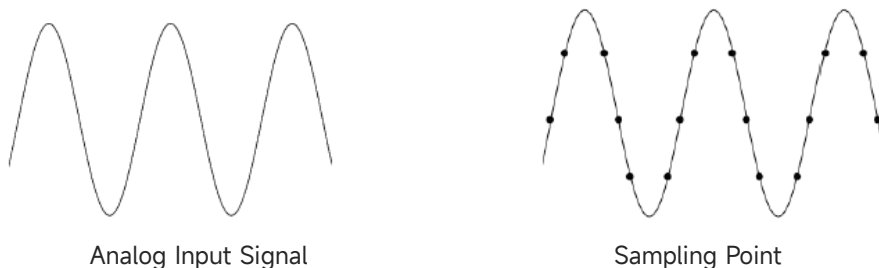

Sampling rate indicates the time interval between two sampling points. The maximum sampling rate of MSO8000HD series mixed signal oscilloscope is 20GSa/s.

The sampling rate will be affected by the number of channel. The single channel is opened at 20GSa/s. The dual channel are opened at 10GSa/s (1、3 channels are 20GSa/s) . Four channel are opened at 10GSa/s.

The sampling rate will change with the time base scale and storage depth.

(2) Effect of Low Sampling Rate

Waveform Distortion: Due to low sampling rate, the details of the waveform might be missing, the sampled waveform might have large different than the actual signal

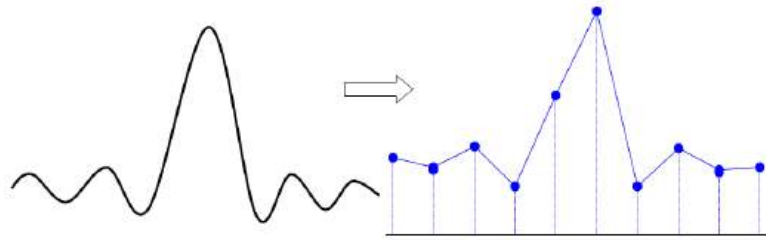

Waveform Aliasing: Since the sampling rate is 2 times lower than the actual signal frequency (Nyquist frequency), the waveform frequency is less than the frequency of actual signal when sampling data is reconstructing.

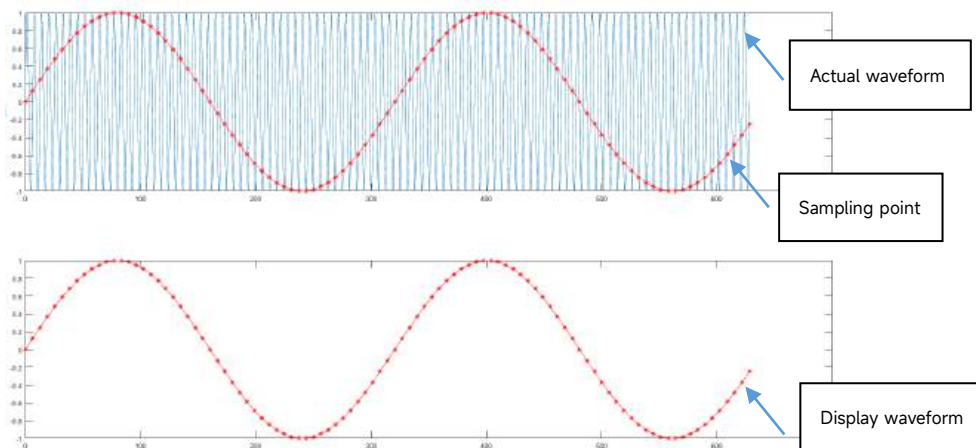

Waveform Missing: Due to the low sampling rate, the waveform does not reflect all the actual signals, as shown in the following figure.

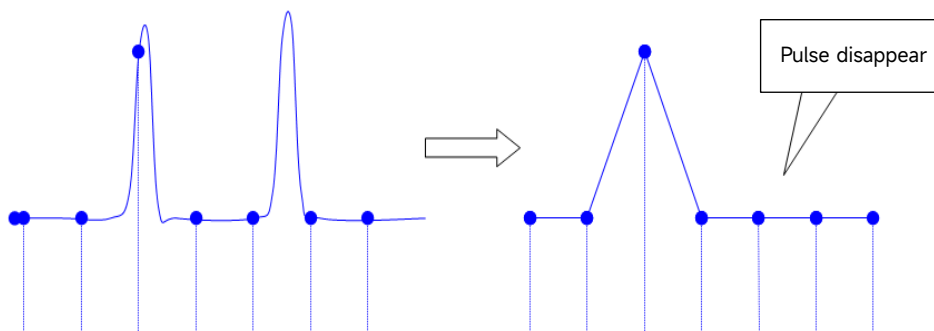

(3) Interpolation Method

The interpolation method means inserting calculated values between the data points collected by the ADC according to a specific algorithm, so as to increase the sampling rate and enable a clearer analysis of signal details.

Linear interpolation: Insert a calculated value between adjacent sampling data points of the ADC according to the calculation method of a linear polynomial. The inserted point is a value on the line connecting two adjacent sampling points.

Sine interpolation: Based on the fact that any waveform can be decomposed into a combination

of sine waves infinitely many times. Through the sine interpolation method, the real waveform signal can be restored more accurately and smoothly. Using curves to connect sample points makes it more versatile. It uses mathematical processing to calculate results in the intervals between actual sample points.

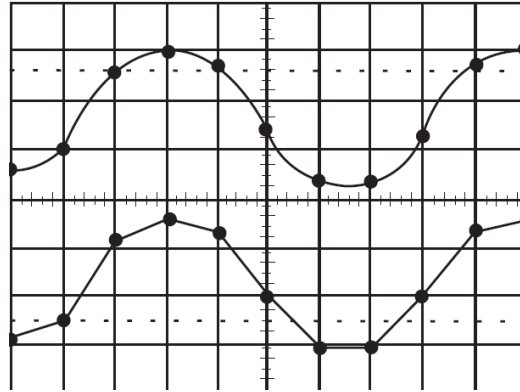

Sine interpolation (upper) & Linear interpolation (lower)

4.2 Acquisition Mode

The acquisition mode can be switched in sampling menu. The acquisition mode has normal sampling, peak detection, high resolution, average sampling.

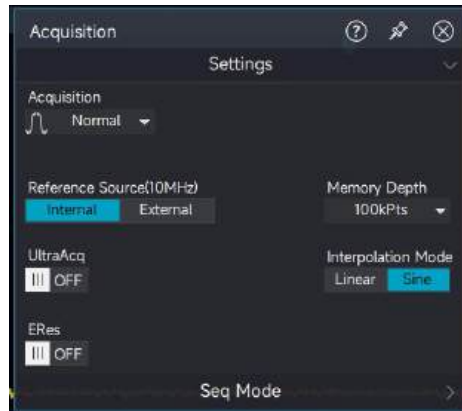

(1) Normal Sampling

The oscilloscope samples the signal and reconstruct the waveform with equal time interval in normal mode. For the most of waveform, this mode can produce the optimal display effect.

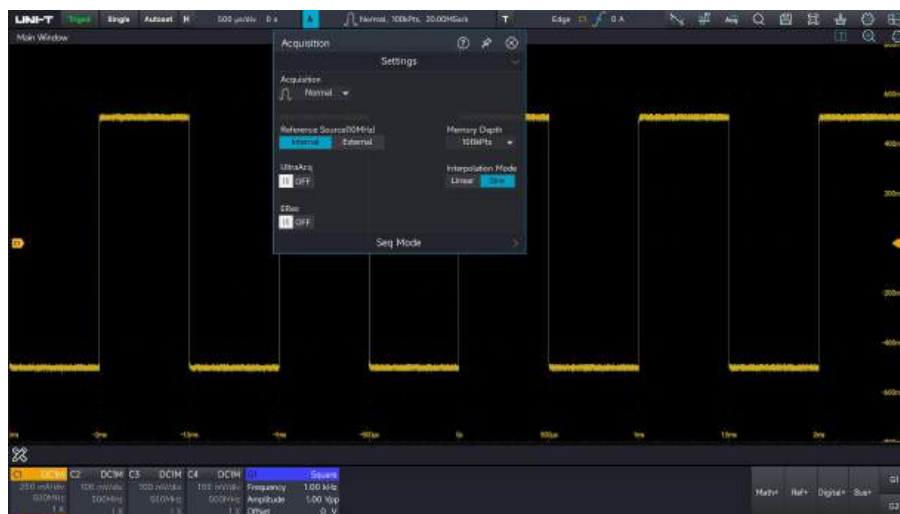

(2) Peak Sampling

The oscilloscope finds the maximum and minimum of the input signal from every sampling interval and using these value to display the waveform. Thus, the oscilloscope can get and display the narrow pulse, otherwise, these narrow pulse will be missed in normal sampling. In this mode, the noise will also look larger.

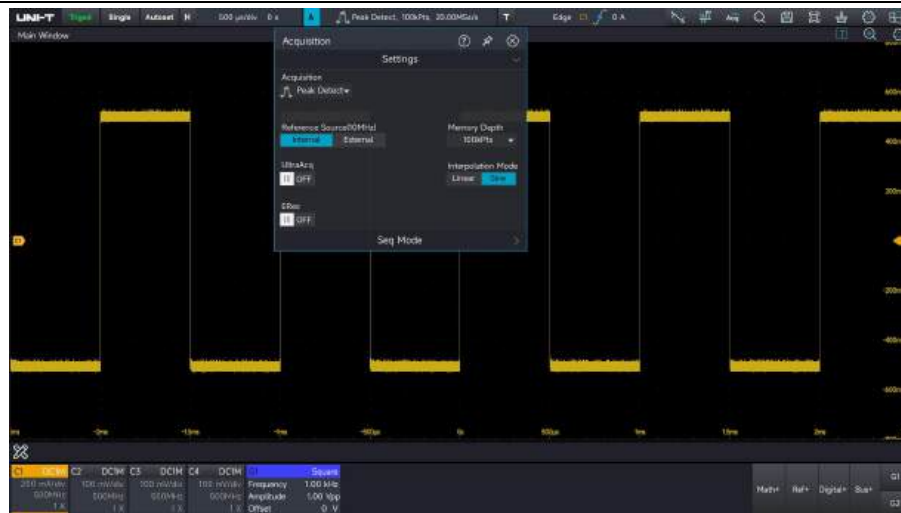

(3) High Resolution

The oscilloscope averages the adjacent point of sampling waveform, it can reduce the random noise of input signal and generate a smoother waveform on the screen.

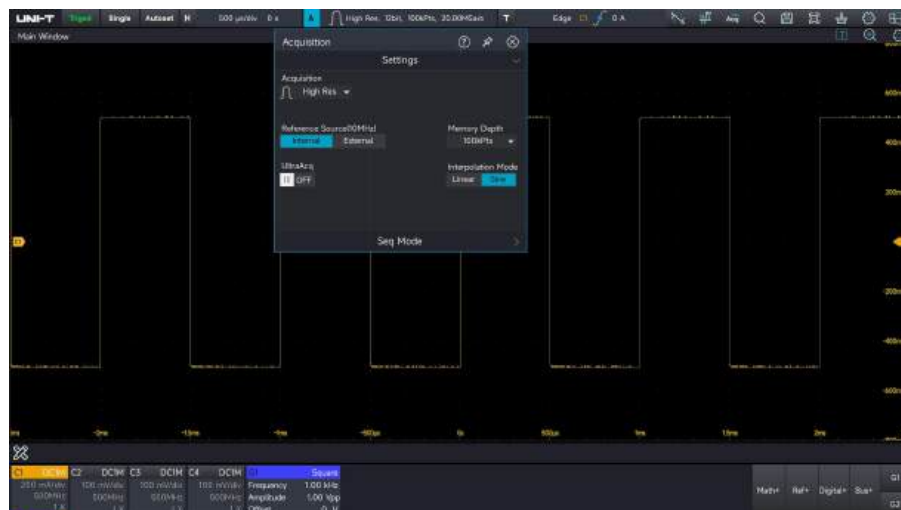

(4) Average

The oscilloscope obtains several waveforms and calculate its averaged value, and then display the final waveform. This mode can reduce the random noise. The maximum average time is 65536.

To observe the waveform by changing the acquisition method. If the signal contains large noise, the waveform does not averaged and the waveform adopts 32 times averaged as shown in the following figure.

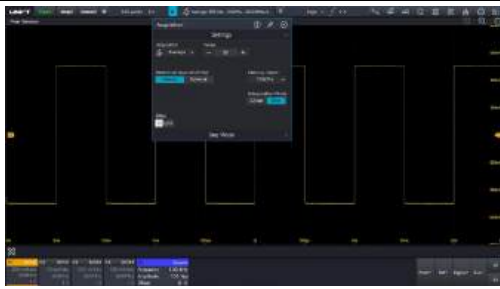

Waveform of 33 Times Averaged

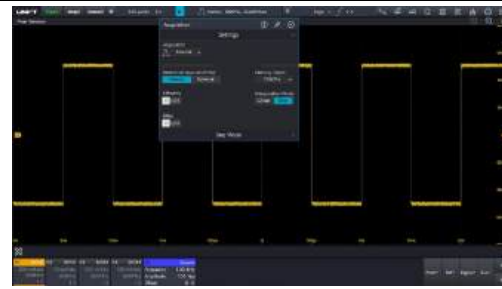

Not Averaged Waveform

Caution: Average and high resolution uses different average methods. The former is “multiple sampling averaged”, the latter is “single sampling averaged”.

4.3 Storage Depth

The storage depth is the number of waveform that can be stored in the oscilloscope during a trigger acquisition. It reflects the memory storage capacity of the memorizer.

The relation of storage depth, sampling rate and waveform length should meet the calculating formula.

$$\text{Storage depth} = \text{sampling rate} \times \text{horizontal time base} \times \text{the number of grid of horizontal direction on the screen}$$

The maximum storage depth of MSO8000HD is 2Gpts (2Gpts: single channel, 1Gpts (multi-channel)).

In “Sampling setup → Storage depth”, when the single channel is opened, the user can freely to set the storage depth to Auto, 100Kpts, 1Mpts, 10Mpts, 100Mpts, 1Gpts.and 2Gpts

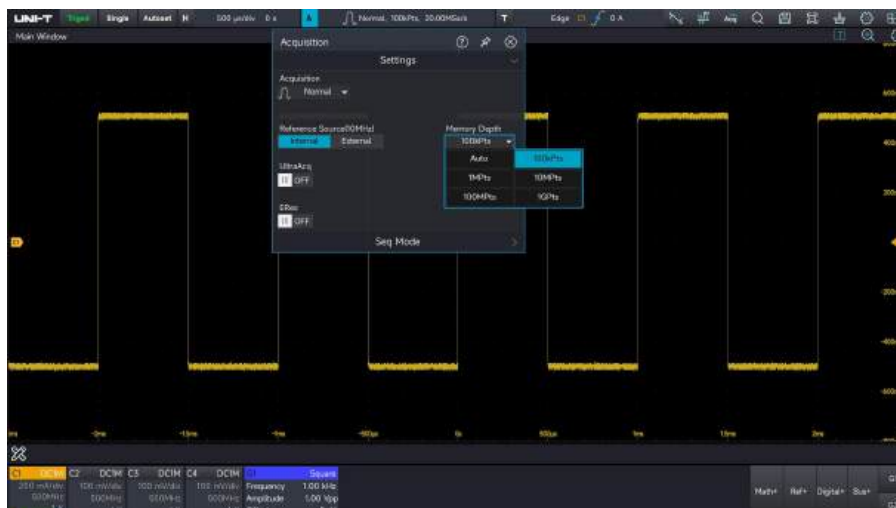

4.4 ERes

In the acquisition, ERes is implemented by FPGA and directly processes the waveforms.

The filtering for enhancing resolution mode (ERes) to improve the signal has two characteristics:

- (1) In any case, using a fixed number of each filter will improve the resolution (that is, the ability to distinguish voltage levels that are very close together). Whether the signal is noisy or not, whether it is a single signal or a repetitive signal, this can effectively improve the resolution.
- (2) The signal-to-noise ratio (SNR) can be improved, depending on the form of noise in the original signal, because the enhanced resolution mode will reduce the signal bandwidth and thereby filter out some of the noise.

Set the ERes mode:

Select ERes in the acquisition function menu and set the enhancement bits (0.5-3bits).



Multiply the oscilloscope bandwidth by the coefficient in the following table to get the bandwidth value under the corresponding enhanced resolution.

Enhanced resolution (bits)	-3dB bandwidth (\times Nyquist)
0.5	0.5
1	0.241
1.5	0.121
2	0.058
2.5	0.029
3	0.016

5. Trigger System

- [Noun of Trigger System](#)
- [Edge Trigger](#)
- [Pulse Width Trigger](#)
- [Video Trigger](#)
- [Slope Trigger](#)
- [Runt Pulse Trigger](#)
- [Delay Trigger](#)
- [Timeout Trigger](#)
- [Duration Trigger](#)
- [Setup & Hold Trigger](#)
- [N-th Edge](#)
- [Pattern](#)
- [Serial Trigger](#)
- [Zone Trigger](#)

Trigger determines when the oscilloscope starts to collect data and display waveform. Once the trigger is correctly set, it can convert unstable signals into stable waveform. In the beginning of data acquisition, it collects enough data to compose the waveform starting at the left of the trigger point, and continues until the trigger condition is met. When a trigger is detected, the oscilloscope will be continuously collect enough data to draw the waveform to the right of the trigger point.

5.1 Noun of Trigger System

Trigger

Trigger is to set certain trigger conditions according to the demand, when a section of the waveform is met the condition, the oscilloscope instantly capture the section of the waveform and its neighboring parts, and display on the screen.

The trigger has two functions, to isolate the interested event and synchronizing waveform or display waveform stably. Only a steady trigger can make display stably.

The trigger circuit ensures that each time base scanning or acquisition starts at the input signal and user-defined trigger condition, that is each scanning and acquisition is overlapped with acquired waveform, thus make waveform display stably.

Trigger Source

A signal is used to generate a trigger. Trigger can obtain from a variety of sources, such as analog channel (C1, C2, C3 and C4), digital channel (D0 ~ D15), Ext, Ext5, AC and Aux In.

1. Analog channel: Select any one of the analog signal input terminal C1-C4 on the front panel of the oscilloscope as a trigger signal.
2. Digital channel: When connect to digital signal and "Digital" is opened, select any one of the digital channel (D0~D15) as a trigger signal.
3. EXT: Select the EXT TRIG (EXT input terminal) on the front panel of the oscilloscope as a trigger signal. For example, the external clock can input to EXT TRIG terminal to be a trigger source. The trigger level range of EXT signal trigger is -1V ~ +1V.
4. AC: The trigger signal is from AC power input of the oscilloscope. The mains supply trigger is usually used to measure signals related to the frequency of the AC power supply. It mainly used in power industry.
5. Aux In: The clock signal input through the Aux In interface is used as a trigger synchronization for clock synchronization between two or more instruments.

Trigger Mode

Trigger mode determines the behavior of the oscilloscope during a trigger condition. This oscilloscope provides three kinds of trigger modes: auto, normal, and single trigger.

- (1) Auto trigger: When there is no trigger signal, the system will automatically collect data and display. When the trigger signal is generated, the system will automatically turn to trigger scanning and synchronize with the signal.

Auto trigger mode is suitable for

- check DC signal or the signal with unknown level characteristic.

- (2) Normal trigger: The oscilloscope can only collect data when the trigger condition is met. The oscilloscope is stop collect data and be wait to trigger state when there is no trigger signal. The oscilloscope will refresh the waveform data when the trigger condition is met. Otherwise, the oscilloscope maintains the last triggered waveform.

Normal trigger mode is suitable for

- only collect the particular event appointed by the trigger setting;
- rare trigger event, use normal mode can prevent the oscilloscope from automatic trigger, so that the waveform can be stable display.

(3) Single trigger: In single trigger mode, press the **Single** key one time to delete the waveform on the screen and the oscilloscope enters wait to trigger state. When the oscilloscope detects a trigger, the waveform will be sampled and displayed, and then the oscilloscope enters the STOP state.

Single trigger mode is suitable for

- capture casual event or aperiodicity signal, such as up, down electrical waveform;
- rare trigger event.

Trigger Coupling

Trigger coupling determines which part of the signal will be transmitted to the trigger circuit. The coupling type includes DC, AC, LF rejection, HF rejection and noise suppression.

- DC: Let all the components of the signal pass through.
- AC: Block the DC component of the signal.
- HF rejection: Attenuate high frequency components over 40kHz.
- LF rejection: Attenuate low frequency components below 40kHz.
- Noise suppression: Suppress high frequency noise in the signal to reduce probability of touch error

Note: Trigger coupling only takes effect for edge triggering.

Pre-trigger/Delay Trigger

Collected data before/after a trigger event.

Trigger position is usually set at the horizontal center of the screen. The user can observe 7 grids of pre-trigger and delay trigger information. The user can move the waveform horizontally to view more pre-trigger information. By observing the pre-trigger data, the waveform before generated can be observed. For example, capturing the glitch at the start of the circuit, observing and analyzing the pre-trigger data to find out the cause of the glitch.

Force Trigger

Press **Force** key to force to generate a trigger signal.

If the waveform is not displayed on the screen in normal or single trigger mode, press **Force** key to sampling signal baseline and confirm whether the sampling is performed properly.

Trigger Holdoff

Trigger holdoff can stably generate complicated and repeat waveform (Waveform repetitions with multiple edges or other events between them, such as pulse string). The trigger holdoff time indicates the oscilloscope waits to restart the trigger circuit. During trigger holdoff, even the trigger condition is met, the oscilloscope will not trigger until the end of holdoff time.

5.2 Edge Trigger

The edge can be triggered by looking for the specific edge (rising edge, falling edge and random edge) on waveform and electrical level. Press the edge trigger menu to set source, trigger coupling, trigger mode and edge type. Waveform can be stable generated when the condition is satisfied

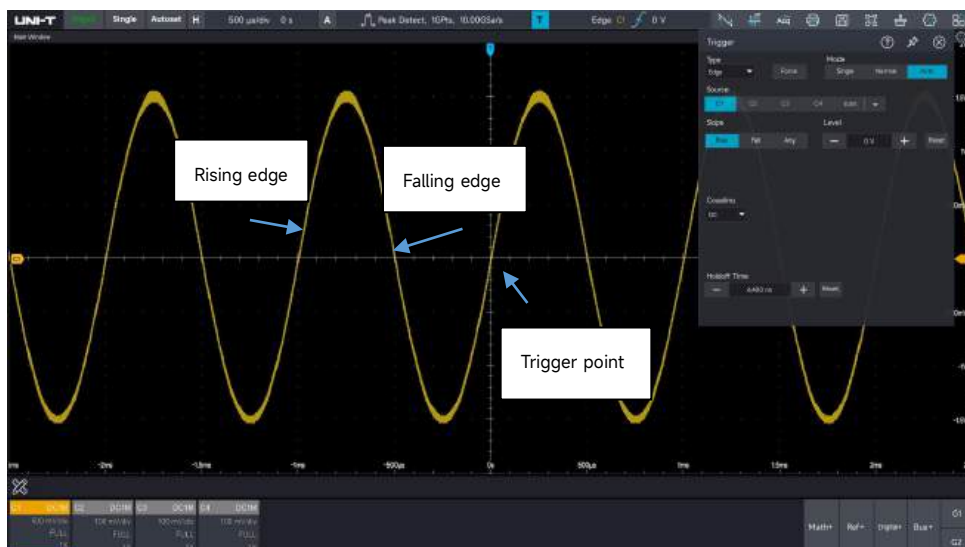

Select source

The edge trigger can select C1 ~ C4/EXT/(EXT/5)/D0 ~ D15/Mains supply trigger.

For more details, please refer to the section of [“Noun of Trigger System”](#).

Select edge type

1. Rising edge: Set to trigger on the rising edge of the signal.
2. Falling edge: Set to trigger on the falling edge of the signal.
3. Random edge: Set to trigger on the rising edge and the falling edge of the signal.

Set threshold level

Set the level position of edge trigger.

5.3 Pulse Width Trigger

Pulse width trigger sets the oscilloscope to be triggered on a positive or negative pulse of a specified pulse width that meets the judgment conditions. The pulse width trigger menu can set the source, pulse width condition, the upper/lower limit of pulse width, pulse width polarity (positive/negative), trigger coupling and trigger mode.

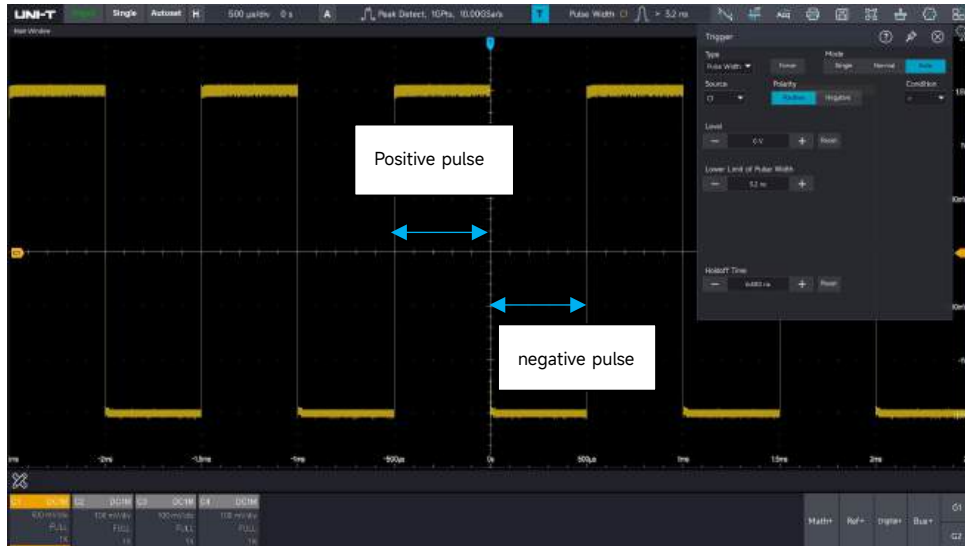

Pulse Width Condition: Select the trigger condition “>”, “<”, “[...]”.

>: When the pulse width of the trigger signal is greater than the set pulse width, the lower limit of pulse width can be set.

<: When the pulse width of the trigger signal is less than the set pulse width, the upper limit of pulse width can be set.

[...]: When the pulse width of the trigger signal is basically similar to the set pulse width, or the signal pulse width is generated in the set range, the lower/upper limit of time can be set.

Upper/Lower Limit of Pulse Width

The pulse width value of the set pulse is compared with the signal pulse width. It will be generated if the trigger condition is met. The setting range for the lower limit of pulse width: 3.2ns - 10s. The setting range for the upper limit of pulse width: 3.2ns - 10s.

5.4 Video Trigger

The video signal includes the image and the time sequence information, it has multiple standards and formats. MSO8000HD can be triggered in the filed or line of NTSC (National Television Standards Committee), PAL (Phase Alternating Line).

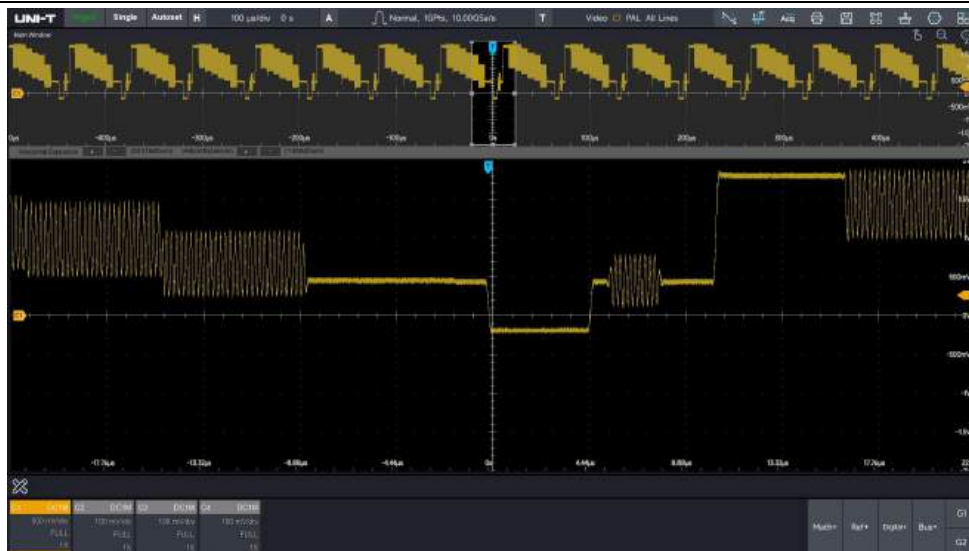

Video Format

PAL: The frame frequency is 25 frames per second, the TV scan line is 625 lines, with the odd field at the front and the even field at the back.

NTSC: The field frequency is 60 fields per second, and the frame frequency is 30 frames per second. The TV scan line is 525 lines, with the even field at the front and the odd field at the back.

Video Synchronization

Even field: Set to trigger and synchronize on the even field of the video signal.

Odd field: Set to trigger and synchronize on the odd field of the video signal.

All lines: Set to trigger and synchronize on the line signal of the video signal.

Specified line: Set to trigger and synchronize on the specified video line. When the specified line is selected, it can assign the line number. The user can use numeric keyboard **-** and **+** adjust the line number. The range of line number is 1 to 625.

Hint: In order to observe the waveform details in the video signal, the user can set the memory depth a little bigger.

The MSO8000HD series utilize the UNI-T original digital 3D technique, it uses a multi-level greyscale display function, so that different brightness can reflect the frequency of different parts of the signal. Experienced users can be quickly judge the signal quality during the debugging process and find the unusual conditions.

5.5 Slope Trigger

The slope trigger refers to generate when the slope of rising or falling of signal conforms to the setting value. The slope trigger menu can set the source, trigger coupling, trigger mode, edge

type (rising edge, falling edge), condition, high/low level and duration time.

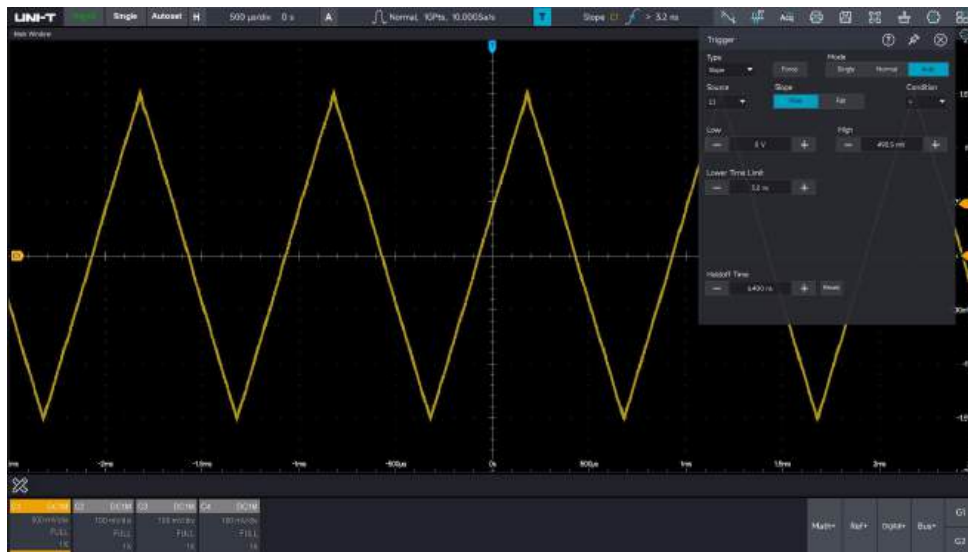

Slope Type

The slope type which is to select the trigger edge for slope.

Rising edge: Perform slope trigger by using the rising edge of the trigger signal.

Falling edge: Perform slope trigger by using the falling edge of the trigger signal.

Condition

Select the trigger condition: “>”, “<”, “[...]”.

>: It will be generated when the slope time of the trigger signal is greater than the set duration time, the lower limit of duration time can be set.

<: It will be generated when the slope time of the trigger signal is less than the set duration time, the upper limit of duration time can be set.

[...]: It will be generated when the slope time of the trigger signal is basically similar to the set slope time or generated in the slope time range, the lower/upper limit of duration time can be set.

Select Level

Level can set to low level, high level and high-low level. Directly press the “Level” rotary knob in trigger control area to quickly switch the selection.

Low level: Adjust the low level threshold of slope trigger by using LEVEL knob on trigger control area.

High level: Adjust the high level threshold of slope trigger by using LEVEL knob on trigger control area.

High-low level: Adjust the high-low level threshold of slope trigger by using LEVEL knob on trigger

control area.

Upper/Lower Limit of Duration Time

Set the slope time, the range can be set to 3.2ns ~ 10s.

Hint: In slope trigger, the set duration time and high-low threshold will display in the right corner of the screen.

Slew Rate

The calculation formula of slew rate value: **(High level threshold - low level threshold) ÷ Time**

For the set slew rate, the time in here is the slope time value for the set slew rate.

5.6 Runt Pulse Trigger

The runt pulse trigger is used to trigger a pulse that has crossed one trigger level but not the other.

In this oscilloscope, the positive runt pulse is the pulse that crosses the low trigger level but does not cross the high trigger level; the negative runt pulse is the pulse that crosses the high trigger level but does not cross the low trigger level.

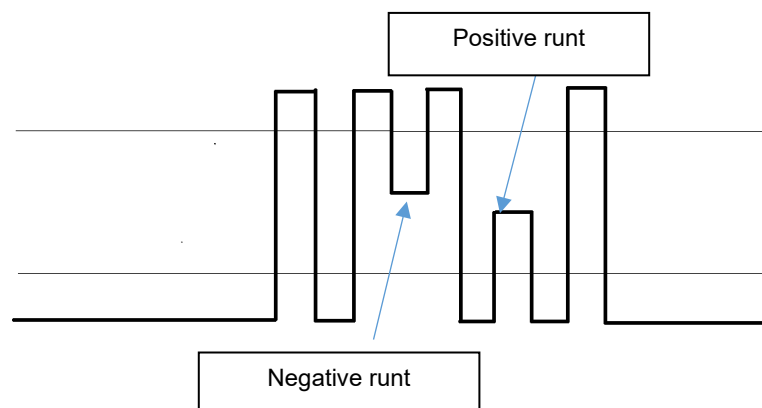

The runt trigger menu can set source, trigger coupling, trigger mode, trigger polarity (positive, negative), condition (irrelevance, <, >, [...]), low level, high level, the upper/lower limit of pulse width.

Trigger Polarity

Positive pulse: Set to trigger on the positive runt pulse.

Negative pulse: Set to trigger on the negative runt pulse.

Condition

Irrelevance: The trigger limit condition of the runt pulse trigger is not set.

>: It will be generated when the runt pulse width is greater than the set pulse width time, the time of lower limit of can be set.

<: It will be generated when the runt pulse width is less than the set pulse width time, the time of upper limit of can be set.

[...]: When the pulse width is in the set range of pulse width, or within the range, the time of upper/lower limit can be set at the same time.

Upper/Lower Limit of Pulse Width

The pulse width value of the set pulse is compared with the channel pulse width. It will be triggered when the condition is met. The range can be set to 3.2ns ~ 10s.

Select Level

Level can set to low level, high level and high-low level. Directly press the “Level” rotary knob in trigger control area to quickly switch the selection.

Low level: Adjust the low level threshold of slope trigger by using LEVEL knob on trigger control area.

High level: Adjust the high level threshold of slope trigger by using LEVEL knob on trigger control area.

High-low level: Adjust the high-low level threshold of slope trigger by using LEVEL knob on trigger control area.

5.7 Delay Trigger

The delay trigger need to set trigger source 1 and trigger source 2. The oscilloscope will be generated when the time difference (ΔT) between the edge set by source 1 (edge 1) and the edge set by source 2 (edge 2) meets the preset time limit, as shown in the following figure.

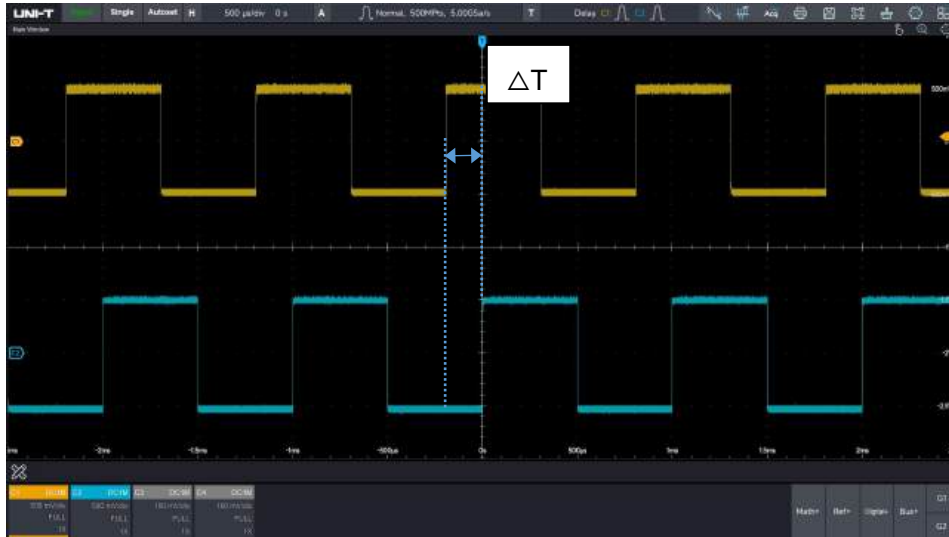

The edge 1 sets to be rising edge, the edge 2 also sets to be rising edge. ΔT indicates the range marked in blue in the figure above.

Caution: The edge 1 and edge 2 must be adjacent edges. Only the channel that has been connected to the signal can get stable trigger.

Delay Trigger: >, <, [...],]...[

>: When the time difference (ΔT) between the edge set by source 1 and the edge set by source 2 is greater than the lower limit of time, the lower limit of time can be set.

<: When the time difference (ΔT) between the edge set by source 1 and the edge set by source 2 is less than the upper limit of time, the upper limit of time can be set.

[...]: When the time difference (ΔT) between the edge set by source 1 and the edge set by source 2 is greater than or equal to the lower limit of time and less than or equal to the upper limit of time, the upper/lower limit can be set.

]...[: When the difference (ΔT) between the edge set by source 1 and the edge set by source 2 is less than the lower limit of time or greater than the upper limit of time, the upper/lower limit can be set.

Upper/Lower Limit of Time

The set time is compared with ΔT , it will be triggered when the condition is met. The range can be set to 3.2ns ~ 10s.

5.8 Timeout Trigger

Timeout trigger is to generate a signal whose time interval (ΔT) from the beginning of the rising edge (or falling edge) of the input signal crossing the trigger level to the end of the adjacent falling edge (rising edge) crossing the trigger level is greater than the set duration, as shown in the following figure.

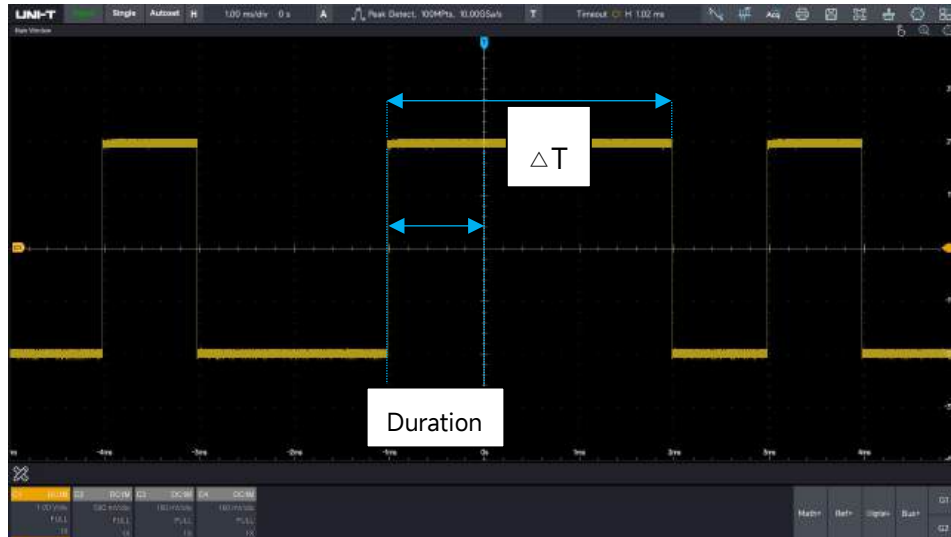

$\Delta T >$ Duration Trigger

Edge Type

Select which edge that the input signal can be triggered. It can select rising edge, falling edge, random rising. The current edge type will display in the top right corner of the screen.

Rising edge: Set the timer to start when the rising edge of the input signal through the trigger level.

Falling edge: Set the timer to start when the falling edge of the input signal through the trigger level.

Random edge: Set the timer to start when the rising edge or the falling edge of the input signal through the trigger level.

Duration

The set duration is compared with ΔT , it will be triggered when duration $< \Delta T$. The time can be set to 3.2ns ~ 10s.

5.9 Duration Trigger

When the duration trigger is selected, the oscilloscope identifies the trigger condition by looking for the duration of the specified codes. The code pattern is the combination of channel logic "AND", and the value of each channel can be H (high), L (low), or X (random). It will be generated when the duration (ΔT) of the code pattern meets a preset time, as shown in the following figure.

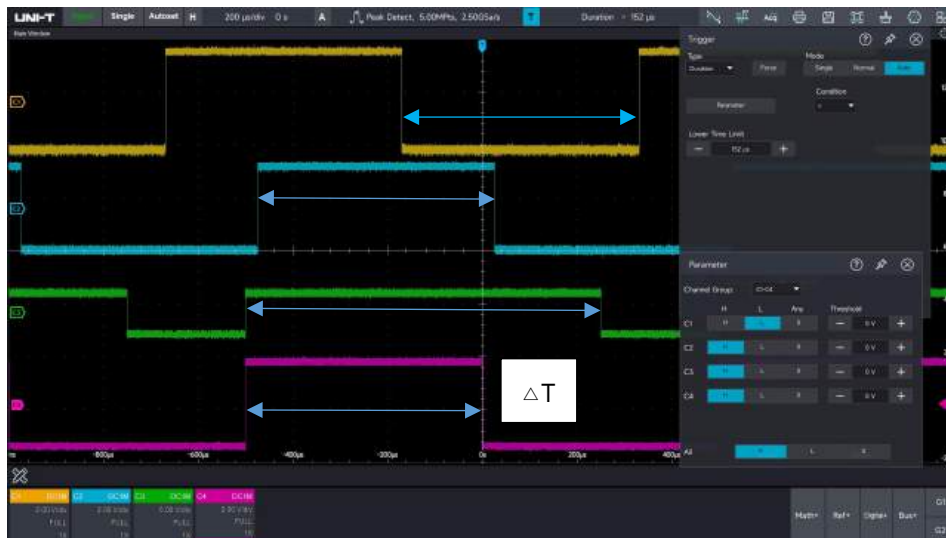

Code Pattern

Click the parameter setup to pop out the window, the code pattern can set to H (High), L (Low) or X (Random). The threshold can judge the voltage of H, L and X.

H: Set the code pattern value of the selected channel to "High", that is, the voltage level is higher than the trigger level of the channel.

L: Set the code pattern value of the selected channel to "Low", that is, the voltage level is lower than the trigger level of the channel.

X: Set the code pattern value of the selected channel to "X", that is, the channel is not part of the pattern. The oscilloscope will not be triggered if all channels in code pattern are set to "X".

Trigger Condition: >, <, [...]

>: When the duration of code pattern is greater than the lower limit of time, it can set the lower limit of time.

<: When the duration of code pattern is less than the upper limit of time, it can set the upper limit of time.

[...]: When the duration of code pattern is less than or equal to the upper limit of time and greater than or equal to the lower limit of time, it can set the upper/lower limit of time.

Upper/Lower Limit of Time

The duration is compared with ΔT , it will be triggered when the condition is met. The range can be set to 3.2ns ~ 10s.

Channel Grouping

The duration trigger supports five channel grouping, four channel in one group, including C1-C4, D0-D3, D4-D7, D8-D11 and D12-D15.

5.10 Setup & Hold Trigger

In setup & hold trigger, the oscilloscope needs to set the data source and clock source.

The setup time begins when the data signal crosses the trigger level and ends when the specified clock edge arrives. The hold time begins when the specified clock edge arrives and ends when the data signal crosses the trigger level again.

The oscilloscope will be triggered when the setup time or the hold time is less than the preset time. It is mainly used to locate and find error code, and quickly find the signal that cannot meet setup & hold time.

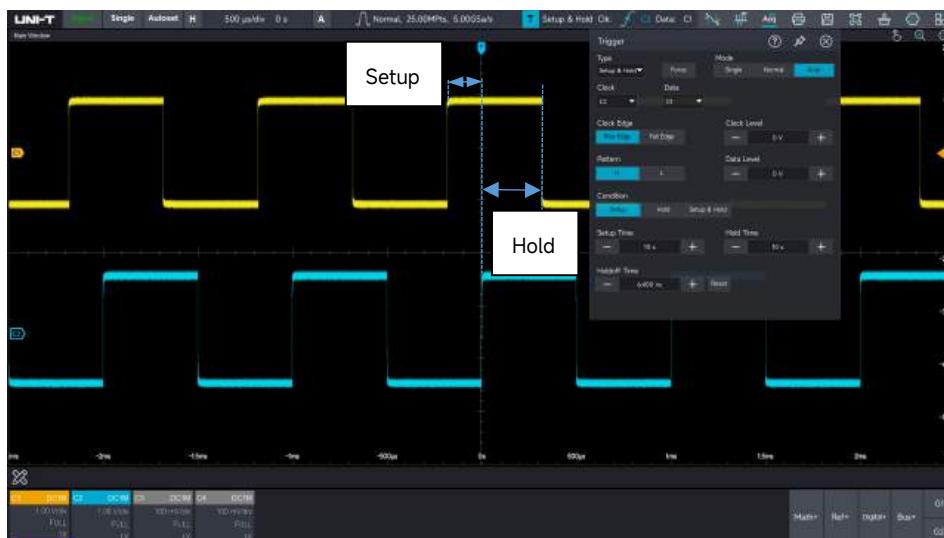

Code Pattern

H (high): Set the valid code pattern of the data signal to high level.

L (low): Set the valid code pattern of the data signal to low level.

Edge Type

Rising edge: Set the clock edge type to rising edge.

Falling edge: Set the clock edge type to falling edge.

Hold Type

Setup: It will be generated when the setup time is less than the set value.

Hold: It will be generated when the hold time is less than the set value.

Setup & Hold: It will be generated when the setup time or hold time is less than the set value.

Level

Clock level: Set the clock source to generate the trigger level.

Data level: Set the data source to generate the trigger level.

Time

The setup time or hold time ΔT of code pattern is compared with the set time, it will be triggered when the condition is met. The range can be set to 3.2ns ~ 10s.

5.11 N-th Edge

The N-th edge trigger is triggered on the N-th edge after assign the specified idle time. For example, the waveform as shown in the following figure, it is set to trigger on the 2nd rising edge after the specified idle time (the time between two adjacent rising edge), then set the idle time to $P < \text{idle time} < M$. M is the time between the 1st rising edge and the next rising edge, P is the maximum time between the counting rising edge, as shown in the following figure.

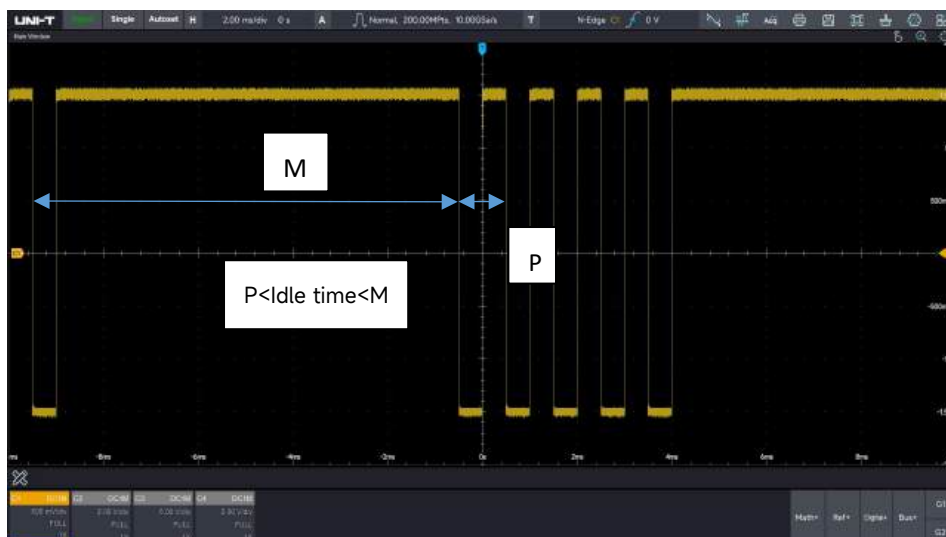

Edge Type

Select which edge that the input signal can be triggered. It can select rising edge or falling edge. The current edge type will display in the top right corner of the screen.



Rising edge: Set to trigger on the rising edge of the signal.

Falling edge: Set to trigger on the falling edge of the signal.

Idle Time

The idle time is compared with the pulse time, it will be triggered when the condition is met. The range can be set to 3.2ns ~ 10s.

Edge Count

The number of edge means that the pulse string is triggered at which edge. Press  and  or numeric keyboard to set the edge value. The edge range is 1 ~ 65535.

5.12 Pattern

The code pattern trigger identifies the trigger condition by looking for the specified code patterns. The pattern trigger type is the combination of the channel logic "AND". Each channel can be set to H (High), L (Low), X (Random). The user can also specify a channel in code pattern as a rising edge or falling edge (only one edge can be specified). When the edge is assigned, if the code pattern of the other channels are judged "true" (i.e., the actual pattern is consistent with the preset pattern type), the oscilloscope will be triggered on the specified edge. If the edge is not assigned, the oscilloscope will be triggered at the last edge of the code pattern "true". If the pattern of all channels are sets to "random", the oscilloscope will not be triggered.

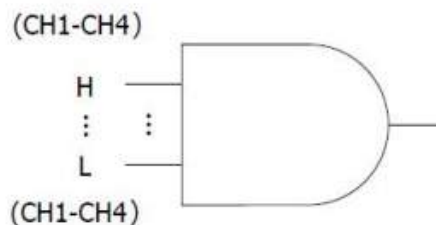

Code Pattern: H (high), L (low), X (random), rising edge, falling edge. The code pattern of each channel will display in the bottom of the screen.

H (high): Set the code pattern value of the selected channel to "High", that is, the voltage level is higher than the trigger level of the channel.

L (low): Set the code pattern value of the selected channel to "Low", that is, the voltage level is lower than the trigger level of the channel.

X (random): Set the code pattern value of the selected channel to "X", that is, the channel is not part of the pattern. The oscilloscope will not be trigger if all channels in code pattern are set to "X".

Rising edge: Set the code pattern to the rising edge of the selected channel.

Falling edge: Set the code pattern to the falling edge of the selected channel.

5.13 Serial

MSO8000HD supports 11 kinds of serial bus trigger, data trigger and event list and search function.

Software Suite	Description	Option	Standard/Option
Computer serial bus trigger analysis	RS-232/422/485/UART	-	Standard
Embedded serial bus trigger analysis	I ² C, SPI	-	Standard
Automobile serial bus trigger analysis	CAN, LIN	-	Standard
Automobile serial bus trigger analysis	CAN-FD	MSO8000HD-CANFD	Option
Automobile serial bus trigger analysis	FlexRay	MSO8000HD-FLEX	Option
Automobile serial bus trigger analysis	SENT	MSO8000HD-SENT	Option
Audio serial bus trigger analysis	I ² S, LJ, RJ, TDM	MSO8000HD-AUDIO	Option
Aerospace serial bus trigger analysis	MIL-STD-1553, ARINC 429	MSO8000HD-AREO	Option

Close

It indicates the serial trigger function is closed.

RS232 Decoding Trigger

(1) Trigger mode: set the trigger mode for RS232

Start bit: The waveform will be triggered at the start bit of RS232 protocol. When user send a single string signal or send the same strings several times, this trigger can be used to see a stable signal waveform, and if the sent data changes, the corresponding waveform will also be change.

Stop bit: The waveform will be triggered at the stop bit of RS232 protocol.

Parity check bit: When RS232 protocol sets the parity check bit, set the parity check bit to 0 or 1 according to the odd-even check.

Odd-even check:

- Odd parity check: If the number of bit 1 in the data bits and the parity bits is odd, the transmission is recognized as correct.
- Even parity check: If the number of bit 1 in the data bits and the parity bits is even, the transmission is recognized as correct.

During the checking of RS232 communication, the odd-even check can quickly find the transmitting procedure of check error, which is convenient for you to locate and analysis the fault.

Data bit: The trigger will be generated when the data acquired by the oscilloscope is the same as the 2 bits hexadecimal system set by the user. Using this option, the user can be quickly find the transmission signal of the specific data that you are interested.

(2)Data: It will be valid when the trigger mode is “Data bit”. In this time, data and the compare mode can be set.

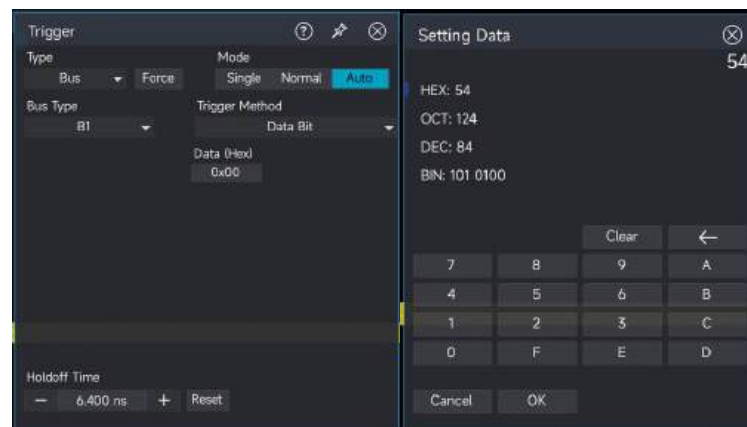

I²C

(1) Trigger mode

- Start bit: It will be triggered when I²C starts to transmit, that is SCL is in high level, a falling edge occurs in SDA signal.
- Restart: Restart trigger means that one start signal was followed by another start signal before a stop occurred.
- Stop: It will be triggered when stop bit occurred, that is SCL is in high level, SDA signal goes from low to high.
- Response failed: In the I²C protocol, every time an 8 bits message is transmitted, the receiver of the data is required to send an answer signal, i.e., an answer bit. Keep SCL in high level, SDA in low level, the loss be triggered in the answer bit, when SCL is high level

and the SDA signal is high level.

- Address: It will be triggered when the communication address is the same with the user-defined. It can help user to quickly locate the address transmission.
- Data: The waveform will be triggered when the data acquired by I²C is the same with the user-defined. It can help user to quickly find the specified data of transmission signal that you are interested.
- Address data: It will be triggered when find the same address during the transmission and data relationship meets the condition. This trigger condition makes it easy to implement the specified address and data trigger of I²C, and help the user to analyze the transmission.

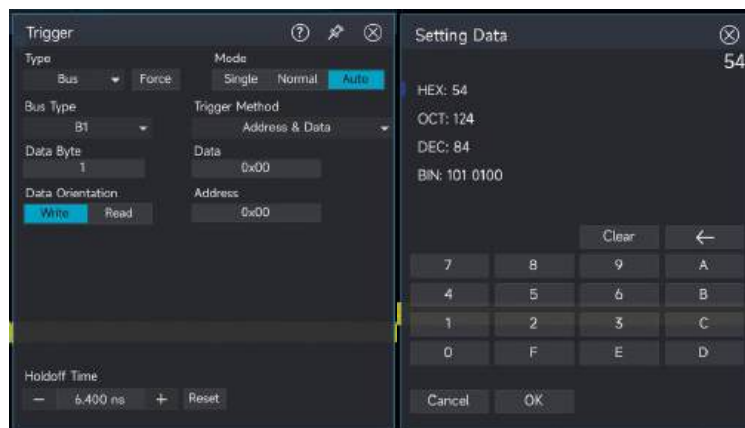

SPI

(1) Trigger mode: set the trigger mode for SPI.

- SS Active: It will be triggered at the edge where the chip level jumps from invalid to available.
- Data: The waveform will be triggered when the data acquired by SPI is the same with the user-defined. It can help user to quickly find the specified data of transmission signal that you are interested.

(2)Frame: Set the data frame, the range is 1~64.

(3)Data bit width: Set the number of data bits, and the settable range is 1~64.

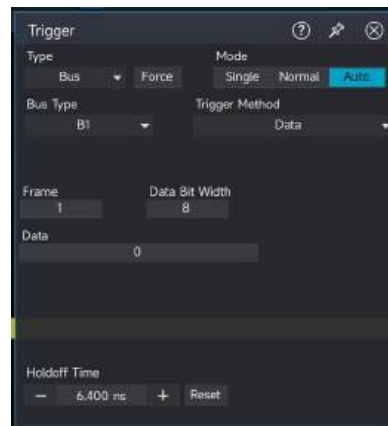

CAN

(1) Trigger mode: set the trigger mode for CAN.

- Start frame: The oscilloscope' waveform will be generated on start frame of CAN signal.
- Frame type
 - A. Data frame: The oscilloscope will be generated on data frame that match to CAN signal.
 - B. Remote frame: The oscilloscope will be generated on remote frame of CAN signal.
 - C. Error frame: The oscilloscope will be generated on error frame of CAN signal.
 - D. Overload frame: The oscilloscope will be generated on overload frame of CAN signal.
- ID: The oscilloscope will be generated on the specified ID.
- Data: The oscilloscope will be generated on data frame that matches the set data condition.
- ID & Data: The oscilloscope will be generated on the specified ID and data frame that matches the set data condition.
- End of frame: It will be generated on the end of frame of CAN signal.
- Error
 - A. Missing acknowledgment: The transmitting node fails to receive a valid acknowledgment signal from the receiving node after data transmission, thus triggering the error - handling mechanism.
 - B. Bit stuffing error: An error detected when six consecutive bits of the same level are detected within a segment where bit stuffing is required.
 - C. CRC error: The receiving node detects a checksum mismatch during the CRC check phase of the data frame, thus determining that the data integrity is compromised and triggering the error handling mechanism.
 - D. All errors: All error conditions detected in the overall bus - decoded data.

(2) ID standard

It will be valid when the trigger mode is "ID" or "ID & Data". It can set "standard format, extension format" and the ID range is different.

(3) ID: It will be valid when the trigger mode is "ID" or "ID & Data". The ID range is 0-2047.

(4) Frame direction: It will be valid when the trigger mode is "ID" or "ID & Data".

Write: It will be generated when the "read/write" bit of the CAN protocol is "Write".

Read: It will be generated when the "read/write" bit of the CAN protocol is "Read".

Random: It will be generated when the "read/write" bit of the CAN protocol is "write or read".

(5) Data: Set the data to be triggered by the user, it will be valid when the trigger condition is "Data" or "ID & Data", the number of bytes of data can be set in relation to the value of bytes, and can be set in the range of 0-255.

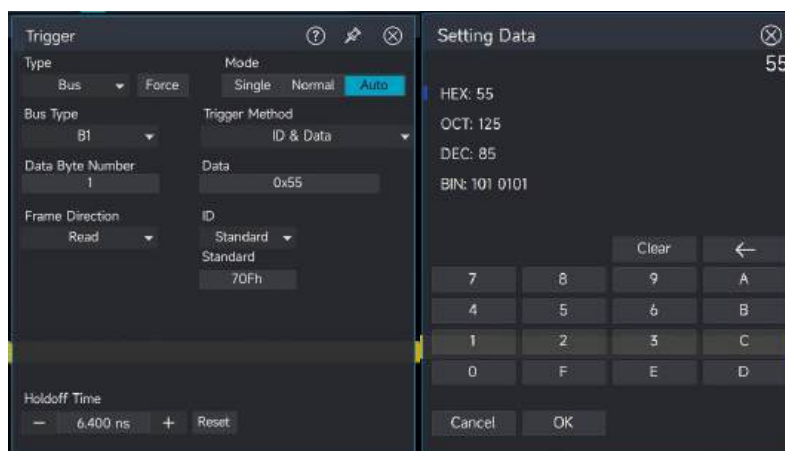

CAN-FD

(1) Trigger mode: set the trigger mode for CAN-FD.

- Start frame: The oscilloscope' waveform will be generated on start frame of CAN-FD signal.
- Frame type
 - A. Data frame: The oscilloscope will be generated on data frame that match to CAN-FD signal.
 - B. Remote frame: The oscilloscope will be generated on remote frame of CAN-FD signal.
 - C. Error frame: The oscilloscope will be generated on error frame of CAN-FD signal.
 - D. Overload frame: The oscilloscope will be generated on overload frame of CAN-FD signal.
- ID: The oscilloscope will be generated on the specified ID.
- Data: The oscilloscope will be generated on data frame that matches the set data condition.
- ID & Data: The oscilloscope will be generated on the specified ID and data frame that matches the set data condition.
- End of frame: It will be generated on the end of frame of CAN-FD signal.

■ Error

- A. Missing acknowledgment: The transmitting node fails to receive a valid acknowledgment signal from the receiving node after data transmission, thus triggering the error - handling mechanism.
- B. Bit stuffing error: An error detected when six consecutive bits of the same level are detected within a segment where bit stuffing is required.
- C. CRC error: The receiving node detects a checksum mismatch during the CRC check phase of the data frame, thus determining that the data integrity is compromised and triggering the error handling mechanism.
- D. All errors: All error conditions detected in the overall bus - decoded data..

(2) ID standard

It will be valid when the trigger mode is "ID" or "ID & Data". It can set "standard format, extension format" and the ID range is different.

(3) ID: It will be valid when the trigger mode is "ID" or "ID & Data". The ID range is 0-2047.

(4) Data: Set the data to be triggered by the user, it will be valid when the trigger condition is "Data" or "ID & Data", the number of bytes of data can be set in relation to the value of bytes, and can be set in the range of 0-255.

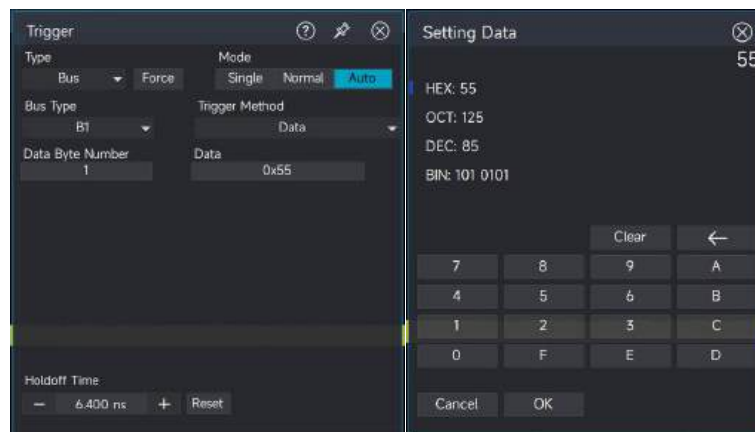

(5) Decoding parameter settings: The trigger decoding parameter settings will be synchronized with the protocol decoding parameter settings. Please refer to the "[CAN-FD](#)" section in the protocol decoding chapter.

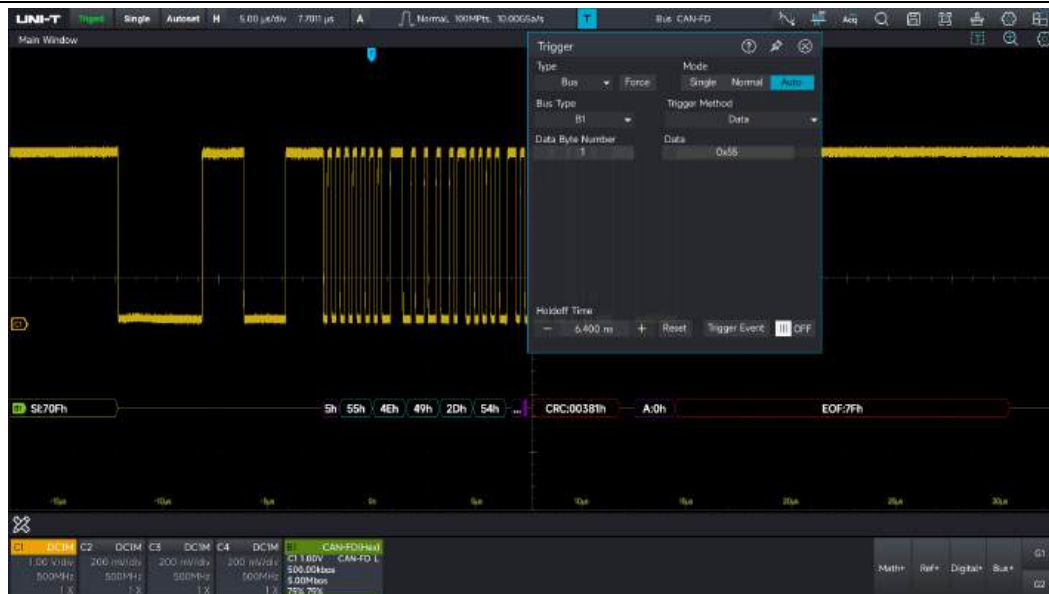

LIN

(1) Trigger mode: set the trigger mode for LIN.

- Start frame: The oscilloscope's waveform will be generated on start frame of LIN signal.
- ID: The oscilloscope will be generated when it detects its ID is equal to the frame of the set value.
- Data: The waveform will be triggered when the data acquired by LIN is the same with the user-defined. It can help user to quickly find the specified data of transmission signal that you are interested.
- ID & Data: The oscilloscope will be generated when it detects its ID and data are equal to the frame of the set value.
- Wake-up frame: The oscilloscope will be generated on wake-up frame of LIN signal.
- Sleep frame: The oscilloscope will be generated on sleep frame of LIN signal.
- Syncerror: It is used to detect and handle errors in LIN bus communication caused by synchronization problems.
- ID validation error: It is used to detect and handle errors in LIN bus communication resulting from identifier check failures.
- Checksum error: Used to detect and handle errors in LIN bus communication caused by checksum mismatches.

(2) ID: It will be valid when the trigger mode is "ID" or "ID & Data". The ID range is 0-255.

(3) Set the data to be triggered by the user, it will be valid when the trigger condition is "Data" or "ID & Data", and can be set in the range of 0-2047.

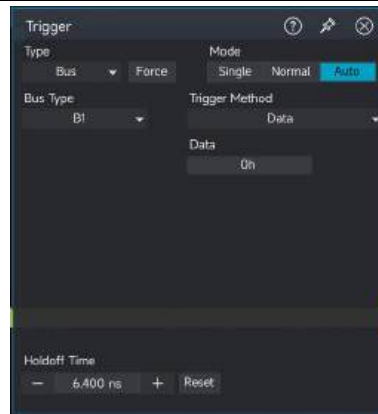

FlexRay

(1) Trigger mode: set the trigger mode for FlexRay.

- Frame header: The oscilloscope will be generated on the transmission start sequence.
- Indicating bit: The waveform will be generated when the acquired information is in accord with the set indicating bit.
- ID: The waveform will be generated when detecting the acquired data is in accord with the judge condition of ID data.
- Cycle number: The waveform will be generated when the acquired cycle number is in accord with the judge condition of the set cycle number.
- Header field: It is used for debugging and analyzing FlexRay bus communication, helping to identify specific frames or detect abnormalities in communication.
- Data: The waveform will be generated when FlexRay protocol acquires the data is in accord with the judge condition of user-defined data. It can help user to quickly find the specified data of transmission signal that you are interested.
- ID & Data: The waveform will be generated when detecting the acquired ID and data is in accord with the judge condition of the set value.
- End of frame: The oscilloscope will be generated on the end of frame.
- Error: The oscilloscope will be generated on bus error, including empty of end frame, empty frame static error, empty frame dynamic error, synchronizing frame error and start frame error (no synchrony).

(2) Indicating bit: Set the indicating bit of FlexRay protocol trigger, which can be normal (01XX), net load (11XX), empty frame (00XX), synchronization frame (XX10) and start frame (XX11).

(3) ID: It will be valid when the trigger condition is "Data" or "ID & Data". The ID range is 0 ~ 65535.

(4) Cycle number: It will be valid when the trigger condition is "cycle number" or "header field".

The range of cycle number is 0-255.

- (5) Data: Set the data to be triggered by the user, it will be valid when the trigger condition is "Data" or "ID & Data". The range is 0-65535.

Trigger data length

Set the length of the data byte to be triggered, different byte length "data" can be set in different ranges. The range of byte length is 1 to 16.

- (6) End of frame: It will be valid when the trigger condition is "end of frame", it can set static state frame, dynamic state frame and all.
- Static state: It will be triggered on static state frame.
 - Dynamic state frame: It will be triggered on dynamic state frame.
 - All: It will be triggered on static state frame and dynamic state frame.
- (7) Error package: It will be valid when the trigger condition is "error", it can set end of frame, empty static state frame, empty frame dynamic error, synchronizing frame error and start frame error (no synchrony).
- End of frame: End frame error of bus.
 - Empty static state frame: Empty static state frame of bus.
 - Empty dynamic state frame: Empty dynamic state frame of bus.
 - Synchronization frame: FlexRay frame has a dedicated indicating bit in the frame header. The data frame is synchronization frame when the indicating bit is valid.
 - Start frame (no synchronizing): FlexRay frame has a dedicated indicating bit in the frame header. The data frame is start frame when the indicating bit is valid.

AudioBus

- (1) Trigger mode: set the trigger mode for AudioBus.

Data: The waveform will be triggered when the data acquired by AudioBus protocol is the same with the data judge condition set by the user-defined. It can help user to quickly find the specified data of transmission signal that you are interested.

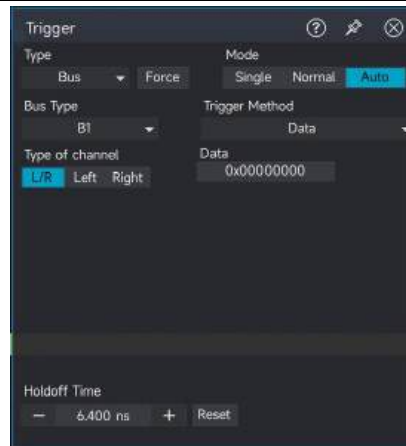

MIL-STD-1553

(1) Trigger mode: set the trigger mode for MIL-STD-1553.

- Command/Status Word: The oscilloscope triggers an event based on specific conditions of the command word or status word in the MIL-STD-1553 signal.
- Data Frame: The oscilloscope triggers an event according to specific conditions of the data word in the MIL-STD-1553 signal.
- Error: The oscilloscope triggers an event based on specific error conditions in the MIL - STD - 1553 signal.
- Synchronous: The oscilloscope triggers an event according to specific conditions of the synchronization word or synchronization segment in the MIL- STD-1553 signal.

(2) Decoding parameter settings: The trigger decoding parameter settings will be synchronized with the protocol decoding parameter settings. Please refer to the "[MIL-STD-1553](#)" section in the protocol decoding chapter.

ARINC429

(1) Trigger mode: set the trigger mode for ARINC429.

- Start of frame: The oscilloscope will be generated on start bit of ARINC429 signal sequence.
- End of Frame: The oscilloscope triggers on the end bit of the ARINC429 signal sequence.
- Tag: It is used to identify the data type, and an event is triggered according to specific conditions of the label field.
- SDI: It is used to identify the source or destination of data, and an event is triggered according to specific conditions of the SDI field.
- Data: When the data collected by the ARINC429 protocol matches the data judgment

conditions set by the user, the oscilloscope triggers.

- SSM: Trigger an event based on specific conditions of the Signal Status Matrix (SSM).
- Tag and Data: Trigger an event based on specific conditions of the Label and Data fields.
- Error: Trigger an event based on specific error conditions.

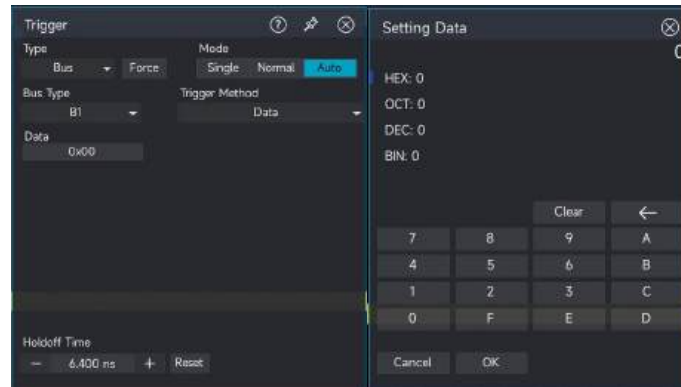

(2) Decoding parameter settings: The trigger decoding parameter settings will be synchronized with the protocol decoding parameter settings. Please refer to the "[ARINC429](#)" section in the protocol decoding chapter.

SENT

The SENT decoding mode is divided into fast - channel mode and slow - channel mode.

(1) The triggering methods in fast - channel mode can be divided into: synchronization, status, data, CRC, status + data, status + data + CRC, and error.

- Sync: It will be triggered when the oscilloscope detects the synchronous pulse of SENT, fixed 56 Ticks.
- Status: Trigger an event according to specific conditions of the status field.
- Data: When the data collected by the SENT protocol matches the data judgment conditions set by the user, the oscilloscope triggers.
- CRC: Trigger an event based on specific conditions of cyclic redundancy check.
- Status + Data: Trigger an event based on specific conditions of the status field and the data field.
- Status + Data + CRC: Trigger an event based on specific conditions of the status field, the data field, and the CRC field
- Error: Trigger an event based on specific error conditions.

(2) The triggering methods in slow - channel mode can be divided into: ID, data, CRC, ID + data, and slow - channel CRC error.

- ID: Trigger based on specific conditions of the ID.

- Data: When the data collected by the SENT protocol meets the data judgment conditions set by the user, the oscilloscope triggers.
- CRC: Trigger an event according to specific conditions of the cyclic redundancy check.
- ID + Data: Trigger an event based on specific conditions of the ID and data fields.
- Slow - channel CRC error: Trigger an event based on specific conditions of the CRC in the slow - channel.

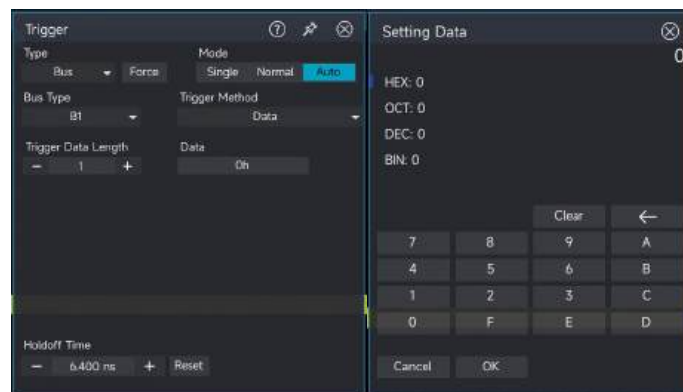

5.14 Zone Trigger

Facing the complex and changeable circuit signals in circuit debugging, it is relatively easy to see the fleeting occasional abnormal signals on the oscilloscope with a high waveform capture rate. However, it may take a lot of time to learn the use of some advanced trigger types to separate the abnormal signals from the complex circuit signals and trigger them stably. Even the powerful advanced triggers may not be able to trigger completely in place. Therefore, the MSO8000HD series adds the zone trigger function based on touchscreen operation, which can greatly speed up this process for users.

The area trigger can be used in combination with the basic trigger, advanced trigger, and protocol trigger, achieving twice the result with half the effort in the debugging of complex signals. Two rectangular areas are provided: Area A and Area B. Both areas support setting the area trigger conditions: intersection / non-intersection;

Source: C1、C2、C3、C4。

The setting menu of the area frame can be set as: intersection, non-intersection.

A: Intersection: The currently drawn zone is the trigger for zone A. Condition: If zone A intersects with the waveform, it triggers; if not, it does not trigger.

A: Non-intersection: The currently drawn zone is the trigger for zone A. Condition: If zone A does

not intersect with the waveform, it triggers; if it does, it does not trigger.

B: Intersection: The currently drawn zone is the trigger for zone B. Condition: If zone B intersects with the waveform, it triggers; if not, it does not trigger.

B: Non-intersection: The currently drawn zone is the trigger for zone B. Condition: If zone B does not intersect with the waveform, it triggers; if it does, it does not trigger.

Dotted points are displayed in the intersection zone, and diagonal lines are displayed in the non-intersection zone. Clicking on the zone trigger frame on the screen will also pop up the setting menu. The horizontal and vertical positions of the zone trigger frame can be moved by touch.

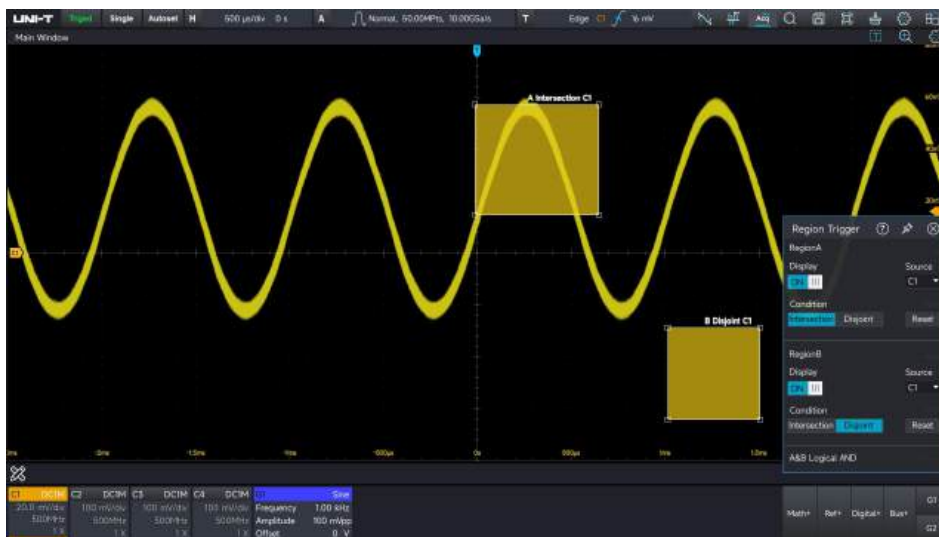

To use the area trigger, the UltraAcq mode needs to be turned on

6. Protocol Decoding (Option)

- [RS232](#)
- [I²C](#)
- [SPI](#)
- [CAN](#)
- [CAN-FD](#)
- [LIN](#)
- [FlexRay](#)
- [AudioBus](#)
- [MIL-STD-1553](#)
- [ARINC429](#)
- [SENT](#)

6.1 RS232

RS232 is asynchronous transmission standard interface established by Electronic Industries Association. It usually includes two application formats DB-9 or DB-25. It suitable for the communication that the data transmission rate within the range 0~29491200/s.

It widely used in microcomputer interface, the data to be transmitted are combined into a specified set of serial bits according to the protocol rules and send it in asynchronous serial way.

The data to be transmitted for each time, composing by the following rules.

Send one start bit at first, and send 5~8 data bits, and send optional parity check bit, and send one or two stop bits at last. The number of data bits is agreed by both communicating parties, it can be 5~8 bits, no parity check bit or odd parity check bit or even parity check bit, stop bit can be set to one bit or two bit. In the following description, a transmission of a data string is referred to as a frame.

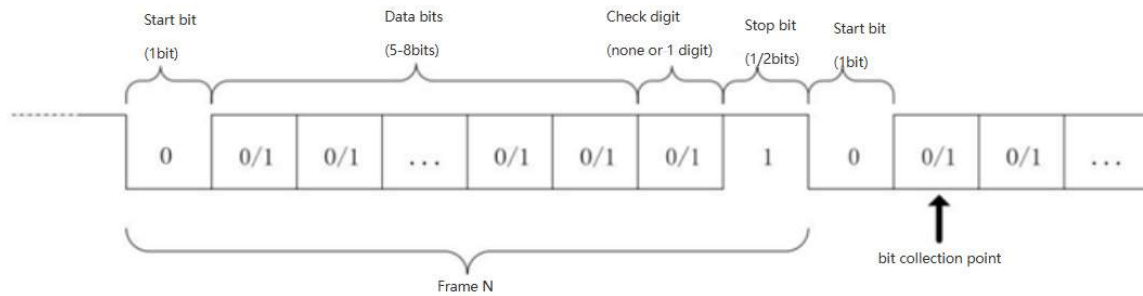

RS232 Decoding Setup

(1) Bus+

Clicking Bus+ on the right bottom of screen or press the **Bus** key in Vertical control area on the front panel to turn on the bus decoding bus menu. Select the RS232 protocol and set bus display, independent window, display format, event list, tab, offset and decoding parameter. The Bus tab on the right bottom of screen will display the set value and state.

B1	RS232(Hex)
C1	1.00V LSB
	115.20kbps Positive
	8bit Stop1.0 None



- Bus display: Set whether to turn on/off the decoding bus.
- Display format: Set the display format for the decoding bus, which can set to hexadecimal, decimal, binary system, ASCII or Auto.
- Event list: The event list displays the decoded data, corresponding line number, time, data, and verified data on the data line in a table format, making it easy to observe longer decoded data.
- Tab: Set the tab name of bus, it will display on the bus signal after the setting is completed, making it easy to distinguish between different bus types.
- Offset: Adjust the bus display position by **-** and **+** the range is -5.5~5.5div

(2) Source

Select the trigger source, which can select C1, C2, C3, C4

Caution: Only the channel that has been connected to the signal and be trigger source can get stable trigger and correct decoding.

(3) Baud rate

The baud rate can select user-defined, 2400 bps, 4800 bps, 9600 bps, 19200 bps, 38400 bps, 57600 bps or 115200 bps.

It's recommended that user sets RS232 according to the hardware and software. RS232 is subject to the basic model of the communication protocol, it usually used in short distance (below 20m) and low speed (below 1 Mbps) transmission occasions. Beyond the range, the communication is susceptible to interference and becomes unreliable. Baud rate in RS232 communication is asynchronous communication. In data transmission process, no accompanying clock signal, in order to solve the determination of data bits, the protocol rule requires that the baud rate should be agreed by both communicating parties.

Generally, the definition of baud rate is the baud rate bit can be transmitted within 1s. For example, 9600 bps indicates 9600 bits can be transmitted within 1s. It is worth to note that the start bit, data bits, check bit and stop bit are all as the bit, so the baud rate is not directly equal to the effective data transmission rate. The oscilloscope will sample the Bit value according to the set baud rate.

(4) Polarity

- Negative: Adverse logical level polarity, that is the high level is 0, the low level is 1.
- Positive: Normal logical level polarity, that is the high level is 1, the low level is 0.
- Threshold: Judge the voltage of signal level, if it exceeds the voltage threshold, it is regarded as high level, and if it is below the voltage threshold, it is regarded as low level.

(5) Bit sequence

To appoint the data bit for RS232 signal to be decoding whether the MSB (the most significant bit) in front or the LSB (least significant bit) in front. It can select to MSB or LSB.

- MSB: The high data bit is transmitted first.
- LSB: The low data bit is transmitted first.

(6) Bit width

To appoint the data bit for RS232 signal to be decoding, it can select to 5 bits, 6 bits, 7 bits or 8 bits.

(7) Stop bit

Set the stop bit for each data, it can set to 1 bit or 2 bits.

(8) Odd-even check

Set the odd-even check for data transmission. It can set to no parity check, even check or odd check.



6.2 I²C

I²C trigger is usually used to connecting microcontroller and peripheral equipment, it's widely applied in micro-electronics area. This bus protocol has two lines to transmit, one line is serial data SDA, and another line is serial clock SCL. Use master-slave system to communication, which can both-way communication for master and slave computer.

This bus is the bus of multiple master, preventing data corruption through conflict demodulation and arbitration mechanisms. It is worth to note that the I²C bus have two address bit width, 7 bits and 10 bits, 10 bits and 7 bits address are compatible and can be used in combination. SCL and SDA in the I²C bus can both be connect to the positive power by pull-up resistor. When the bus is idle, both lines are high level. When any device on the bus output the low level, it will make the bus signal become low, i.e., logical "AND" between the signals of multiple devices. This special logical relation is the key to realize the bus arbitration. The protocol requires that the data SDA must remain stable while the clock line SCL is high, and the data is usually transmitted in MSB form.

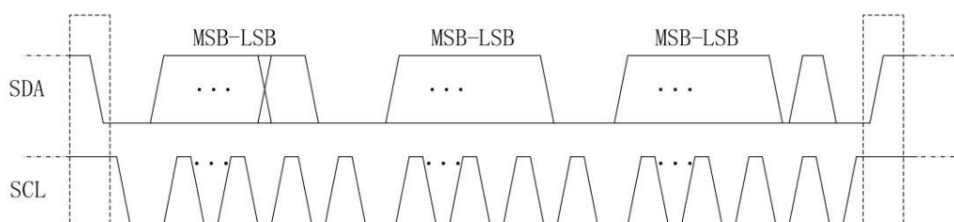

I²C Decoding Setup

(1) Bus+

Clicking Bus+ on the right bottom of screen or press the **Bus** key in Vertical control area on the front panel to turn on the bus decoding bus menu. Select the I²C protocol and set bus display, independent window, display format, event list, tab, offset and decoding parameter. The Bus tab on the right bottom of screen will display the set value and state.

```
B1 I2C(Hex)
SCLK: C2 1V
SDA: C1 1V
7bit
```



- Bus display: Set whether to turn on/off the decoding bus.
- Display format: Set the display format for the decoding bus, which can set to hexadecimal, decimal, binary system, ASCII or Auto.
- Event list: The event list displays the decoded data, corresponding line number, time, data, and verified data on the data line in a table format, making it easy to observe longer decoded data.
- Tab: Set the tab name of bus, it will display on the bus signal after the setting is completed, making it easy to distinguish between different bus types.
- Offset: Adjust the bus display position by **-** and **+** the range is -5.5~5.5div.

(2) Source

Select the trigger source, which can select C1, C2, C3, C4

Data input: Select a channel to be the data channel, which can select C1, C2, C3, C4 or D0-D15.

Clock input: Select a channel to be the clock channel, which can select C1, C2, C3, C4 or D0-D15.

(3) Threshold

Set the voltage for judging the trigger level of the signal, which can set data threshold and clock threshold.

(4) Bit width: 7 bits or 10 bits.

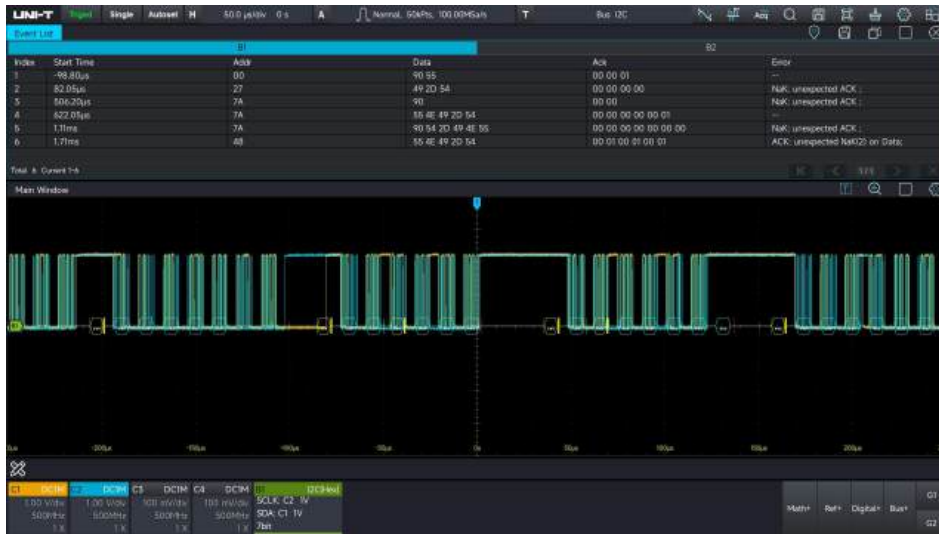

6.3 SPI

SPI (serial peripheral interface) can connect the host with peripheral equipment in serial way to communication. It's full duplex and synchronous communication bus. It's usually use 4 signal connecting line, MOSI: data output from master device, data input from slave device; MISO: data input from master device, data output from slave device; SCLK: clock signal is generated by master device; CS: chip select enable signal from slave device.

SPI interface is mainly used for synchronous serial data transfer between the host and low-speed peripheral equipment. Under the shift pulse of the master device, the data is transferred bit by bit, the transmission format is MSB. SPI interface is widely used because it does not require slave address addressing, which is full duplex communication and the protocol is simple.

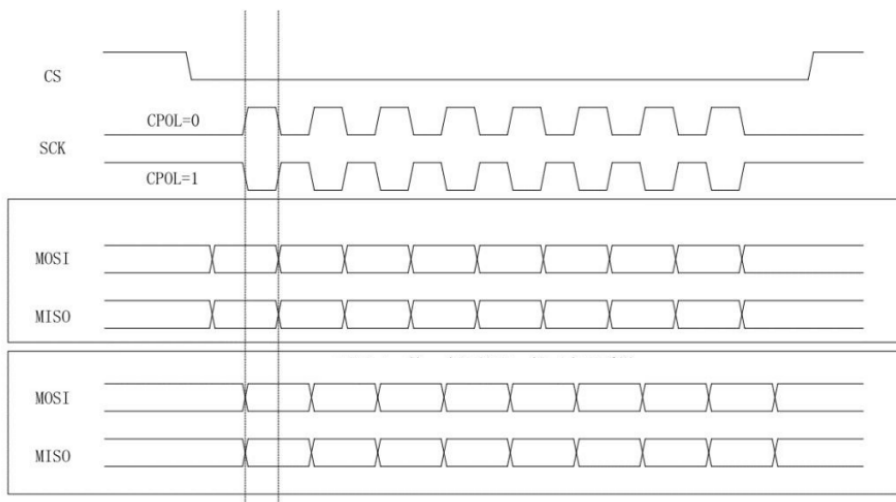

SPI Decoding Setup

(1) Bus+

Clicking Bus+ on the right bottom of screen or press the **Bus** key in Vertical control area on the front panel to turn on the bus decoding bus menu. Select the SPI protocol and set bus display, independent window, display format, event list, tab, offset and decoding parameter. The Bus tab on the right bottom of screen will display the set value and state.

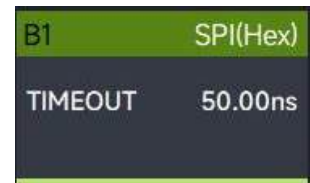

- Bus display: Set whether to turn on/off the decoding bus.
- Display format: Set the display format for the decoding bus, which can set to hexadecimal, decimal, binary system, ASCII or Auto.
- Event list: The event list displays the decoded data, corresponding line number, time, data, and verified data on the data line in a table format, making it easy to observe longer decoded data.
- Tab: Set the tab name of bus, it will display on the bus signal after the setting is completed, making it easy to distinguish between different bus types.
- Offset: Adjust the bus display position by **-** and **+** the range is -5.5~5.5div.

(2) Decoding mode

- TIMEOUT: Set this mode to ensure that data frames can be accurately segmented in non-ideal communication environments, enabling correct decoding
- CS: The control signal by which the master device selects the slave device

(3) Clock input: Any one of C1-C4 can be as clock signal input of SPI decoding signal.

Clock edge: Rising edge/falling edge

Clock threshold: The voltage that determines the trigger level of clock signal.

(4) Data input: Any one of C1-C4 can be set as clock signal input of the SPI decoding signal.

Data Polarity: Negative Polarity / Positive Polarity

Data Threshold: The voltage for judging the polarity of MOSI data. If it is higher than the threshold, it is positive polarity; otherwise, it is negative polarity.

(7) Bit order: Set the bit sequence of SPI protocol signal whether is MSB or LSB.

MSB: The high data bit is transmitted first.

LSB: The low data bit is transmitted first.



6.4 CAN

CAN, which is Controller Area Network. Due to its high-performance, high reliability and special design, CAN is getting more and more attention. CAN is usually single/two-wire system and using unshielded/shielded twisted pair for data transmission. The signal type are CAN_H and CAN_L.

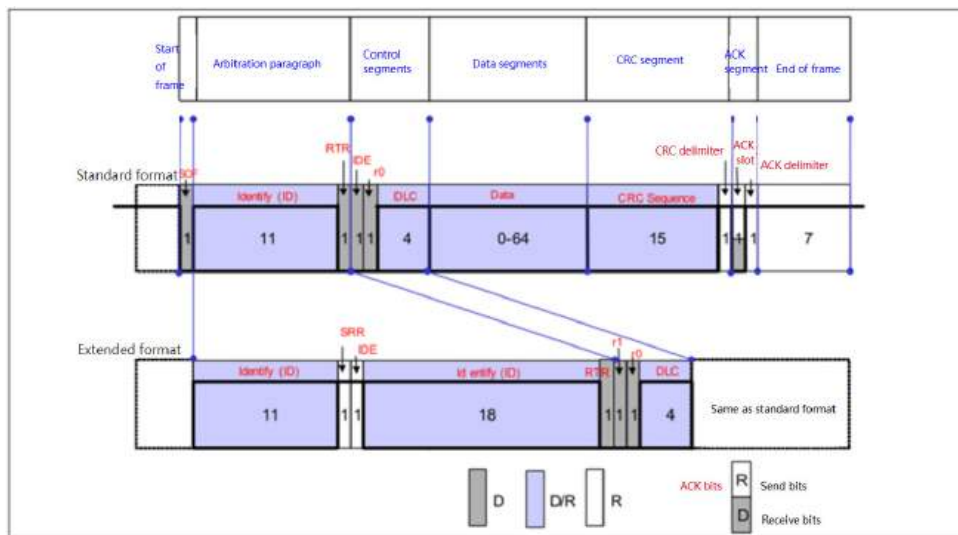

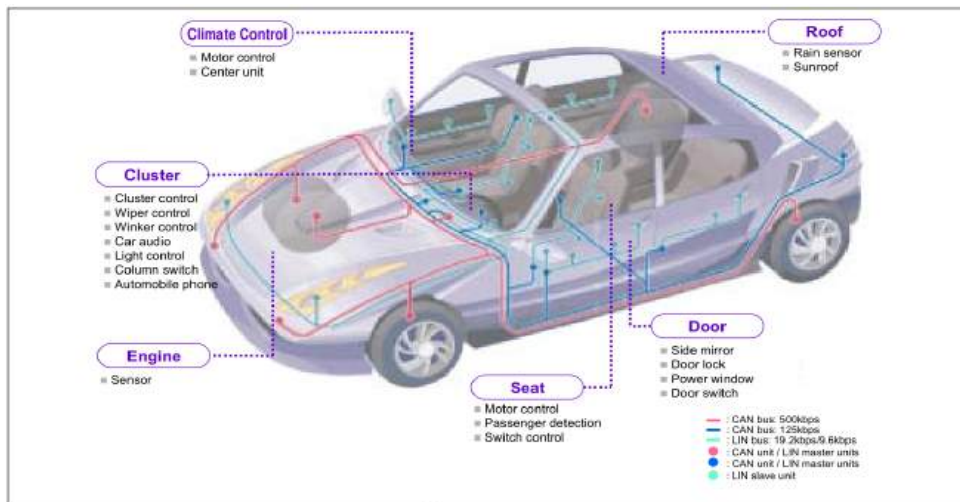

Application Example of CAN

CAN Decoding Setup

(1) Bus+

Clicking Bus+ on the right bottom of screen or press the **Bus** key in Vertical control area on the front panel to turn on the bus decoding bus menu. Select the CAN protocol and set bus display, independent window, display format, event list, tab, offset and decoding parameter. The Bus tab on the right bottom of screen will display the set value and state.

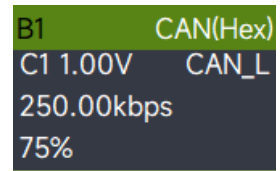

- Bus display: Set whether to turn on/off the decoding bus.
- Display format: Set the display format for the decoding bus, which can set to hexadecimal, decimal, binary system, ASCII or Auto.
- Event list: The event list displays the decoded data, corresponding line number, time, data, and verified data on the data line in a table format, making it easy to observe longer decoded data.

- Tab: Set the tab name of bus, it will display on the bus signal after the setting is completed, making it easy to distinguish between different bus types.
- Offset: Adjust the bus display position by **-** and **+** the range is -5.5~5.5div.

(2) Signal type: Set whether the connected signal of current source is a high data line signal or a low data line signal. It can set CAN_H and CAN_L.

(3) Signal input: Any one of C1-C4 can be a signal input for CAN decoding signal.

(4) Signal rate: 10kbps, 19.2kbps, 20kbps, 33.3kbps, 38.4kbps, 50kbps, 57.6kbps, 62.5kbps, 83.3kbps, 100kbps, 115.2kbps, 125kbps, 230.4kbps, 250kbps, 490.8kbps, 500kbps, 800kbps, 921.6kbps, 1Mbps, 2Mbps, 3Mbps, 4Mbps, 5Mbps and user-defined.

Protocol standards and specifications of CAN

Name	Baud rate	Specification	Applicable fields
SAE J1939-11	250k	Bifilar, shielded twisted pair	Trucks, buses
SAE J1939-12	250k	Bifilar, shielded twisted pair, Powered by 12V	Agricultural machinery
SAE J2284	500k	Bifilar, Unshielded Twisted Pair (UTP)	Automobiles (high - speed, power, transmission systems)
SAE J24111	33.3k, 83.3k	Unifilar type	Automobiles (low - speed, body systems)
NMEA-2000	62.5k, 125k, 250k, 500k, 1M	Bifilar, Power supply via shielded twisted pair	Ships
DeviceNet	125k, 250k, 500k	Bifilar, shielded twisted pair, Powered by 240V	Industrial equipment
CANopen	10k, 20k, 50k, 125k, 250k, 500k, 800k, 1M	Bifilar, Twisted pair (shielding and power supply optional)	Industrial equipment
SDS	125k, 250k, 500k, 1M	Bifilar, shielded twisted pair (power supply optional)	Industrial equipment

(5) Sampling point: The sampling point is the point between times, the oscilloscope samples the bit level of this point. The sampling point is expressed as a percentage of the “time from the start of the bit to the sampling point” and the “bit time”, and can be set from 30% to 90%.

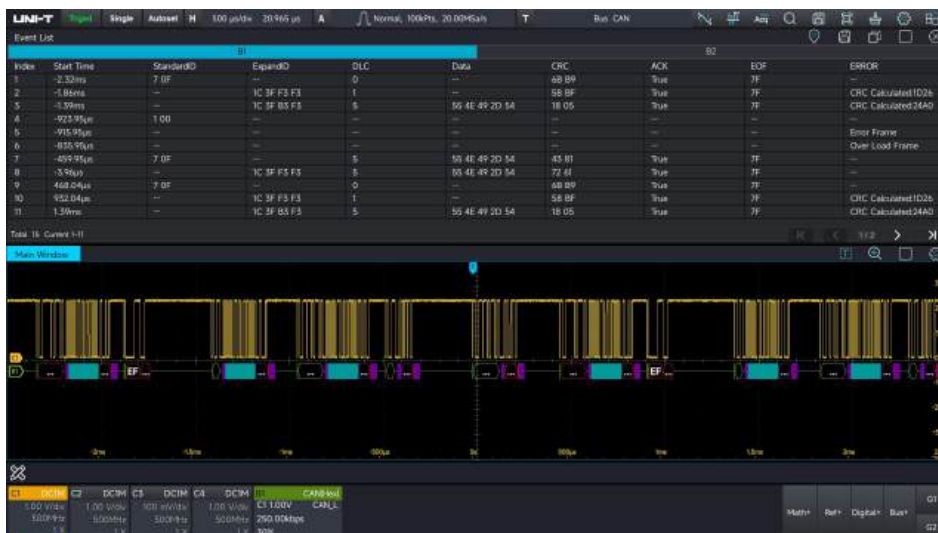

6.5 CAN-FD

CAN-FD (CAN-Flexible Data Rate) is a new standard developed by Bosch in 2011, which aims to increase the bandwidth of the CAN bus while retaining the core characteristics of the traditional CAN bus. Compared to the CAN protocol, CAN-FD has higher transmission rates and longer data lengths. It can be regarded as an upgraded version of CAN, with only the protocol changing, but the physical layer remaining unchanged, CAN-FD improves data transmission and load capacity.

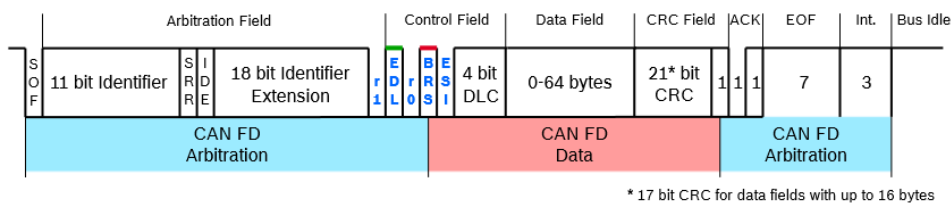

CAN-FD Decoding Setup

(1) Bus+

Clicking Bus+ on the right bottom of screen or press the **Bus** key in Vertical control area on the front panel to turn on the bus decoding bus menu. Select the CAN-FD protocol and set bus display, independent window, display format, event list, tab, offset and decoding parameter.

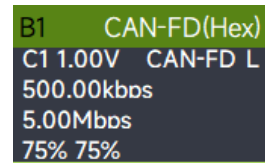

The Bus tab on the right bottom of screen will display the set value and state.



- Bus display: Set whether to turn on/off the decoding bus.
- Display format: Set the display format for the decoding bus, which can set to hexadecimal, decimal, binary system, ASCII or Auto.

- Event list: The event list displays the decoded data, corresponding line number, time, data, and verified data on the data line in a table format, making it easy to observe longer decoded data.
- Tab: Set the tab name of bus, it will display on the bus signal after the setting is completed, making it easy to distinguish between different bus types.
- Offset: Adjust the bus display position by **-** and **+** the range is -5.5~5.5div.

(2) Signal type: Set whether the connected signal of current source is a high data line signal or a low data line signal. It can set CAN-FDH and CAN-FDL.

(3) Signal input: Any one of C1~C4 can be a signal input for CAN-FD decoding signal.

(4) SD signal rate: 10kbps, 19.2kbps, 20kbps, 33.3kbps, 38.4kbps, 50kbps, 57.6kbps, 62.5kbps, 83.3kbps, 100kbps, 115.2kbps, 125kbps, 230.4kbps, 250kbps, 490.8kbps, 500kbps, 800kbps, 921.6kbps, 1Mbps, 2Mbps, 3Mbps, 4Mbps, 5Mbps and user-defined.

(5) FD signal rate: 250kbps, 500kbps, 800kbps, 1Mbps, 1.5Mbps, 2Mbps, 3Mbps, 4Mbps, 5Mbps, 6Mbps, 7Mbps, 8Mbps and user-defined.

(6) Arbitration field sampling point: In CAN - FD bus communication, it is the moment when the receiver samples the signal in the arbitration field.

(7) Data field sampling point: The location at which the signal is sampled within the data section of the CAN - FD frame.

Sampling point: The sampling point is a point within the bit time. The oscilloscope samples the bit level at this point. The sampling point is expressed as the percentage of "the time from the start of the bit to the sampling point" to "the bit time", and can be set from 30% to 90%.

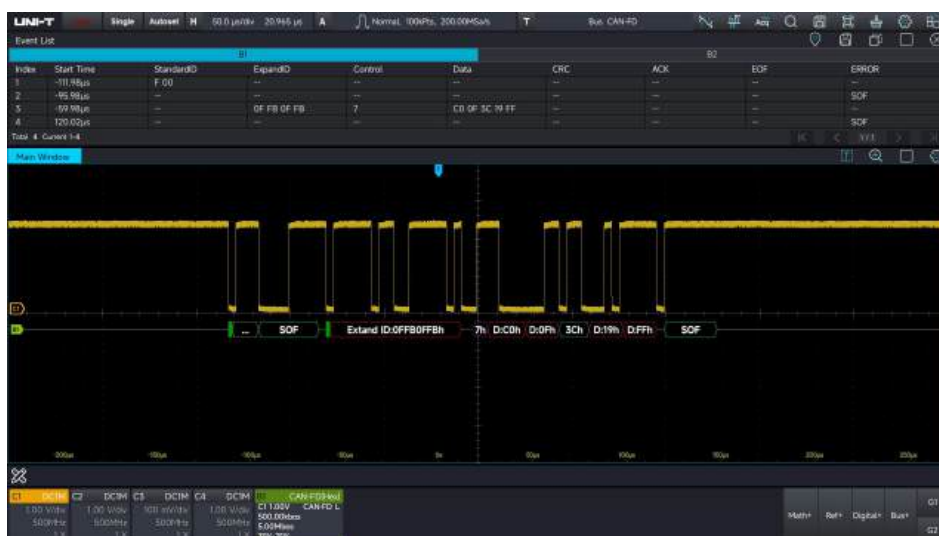

6.6 LIN

LIN (Local Interconnect Network) bus is a low-cost serial communication protocol based on UART/SCI (Universal Asynchronous Transceiver/Serial Communication Interface). Compared with CAN bus, LIN bus protocol is simpler and does not require high requirements for microcontrollers, which can be realized with basic serial ports, thus the cost is lower.

As the auxiliary bus of CAN bus, LIN bus is widely used in the field of car body control, such as doors, windows, lights and central locking. The following figure shows the message structure of LIN.

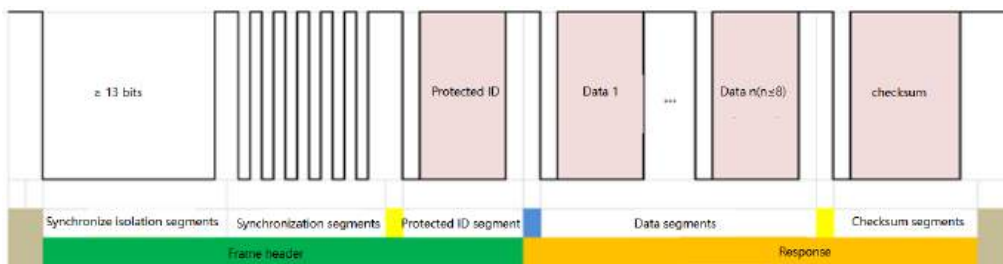

LIN Decoding Setup

(1) Bus+

Clicking Bus+ on the right bottom of screen or press the **Bus** key in Vertical control area on the front panel to turn on the bus decoding bus menu. Select the LIN protocol and set bus display, independent window, display format, event list, tab, offset and decoding parameter. The Bus tab on the right bottom of screen will display the set value and state.

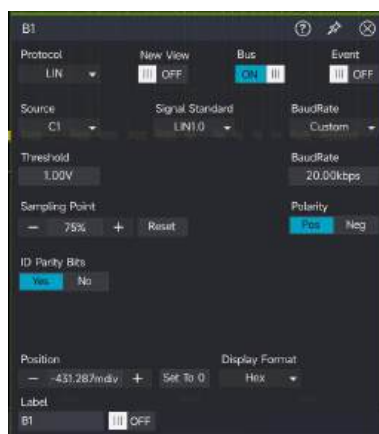
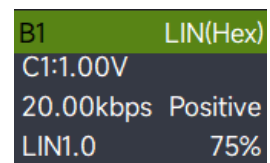

- Bus display: Set whether to turn on/off the decoding bus.
- Display format: Set the display format for the decoding bus, which can set to hexadecimal, decimal, binary system, ASCII or Auto.
- Event list: The event list displays the decoded data, corresponding line number, time, data,

and verified data on the data line in a table format, making it easy to observe longer decoded data.

- Tab: Set the tab name of bus, it will display on the bus signal after the setting is completed, making it easy to distinguish between different bus types.
- Offset: Adjust the bus display position by **-** and **+** the range is -5.5~5.5div.

(2) Source: Any one of C1-C4 can be a clock signal for LIN decoding signal.

(3) Polarity: Positive and negative

- Negative: Adverse logical level polarity, that is the high level is 0, the low level is 1.
- Positive: Normal logical level polarity, that is the high level is 1, the low level is 0.

(4) Threshold: Judge the voltage of signal level, if it exceeds the voltage threshold, it is regarded as high level, and if it is below the voltage threshold, it is regarded as low level.

(5) Baud rate: Set the signal rate of LIN. It can set to 2400 bps, 4800 bps, 9600 bps, 19200 bps or user-defined.

(6) Signal standard: Set the signal standard of LIN. It can set LIN1.0, LIN2.0.

(7) Sampling point: The moment when the receiver samples the bus level.

(8) ID includes parity bits: Combine the ID and parity check bits to form an 8 - bit field called the Protected Identifier (PID).

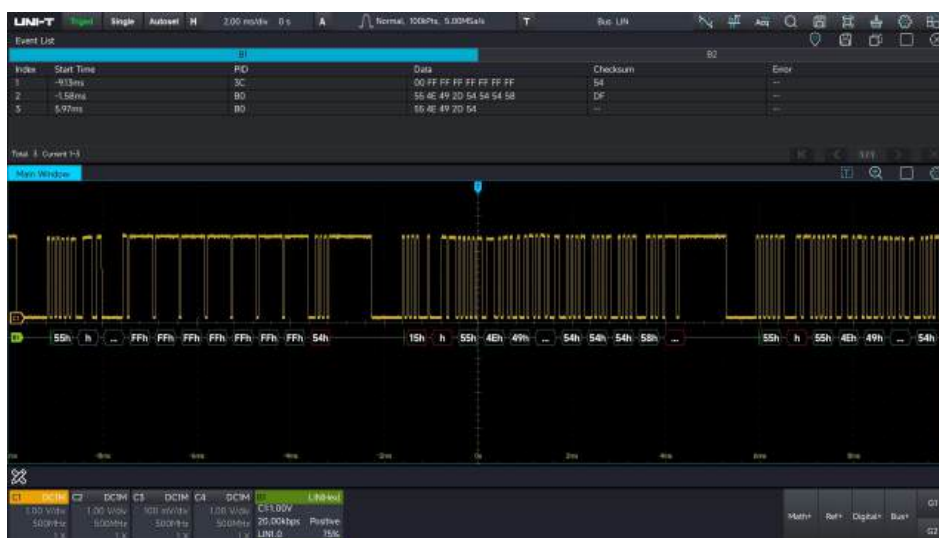

6.7 FlexRay

FlexRay is a differential serial bus configured with three consecutive segments (header, payload and trailer). An oscilloscope samples the FlexRay signal at a specified sample position and also determines whether each data point is a logic “1” or a logic “0” based on a set threshold level.

FlexRay decoding requires a specified signal type and signal rate. FlexRay is a high-speed, deterministic, fault-tolerant bus technology for automotive applications that combines event-triggered and time-triggered modes for efficient network utilization and system flexibility.

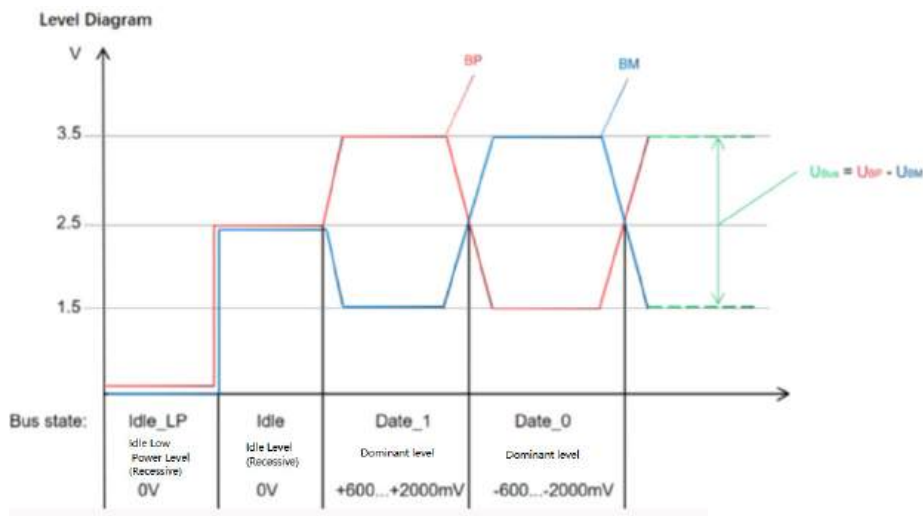

Dominance: the differential voltage is not 0V (Data_0 and Data_1)

Hidden: the differential voltage is 0 V (Idle_Lp, Idle)

FlexRay Decoding Setup

(1) Bus+

Clicking Bus+ on the right bottom of screen or press the **Bus** key in Vertical control area on the front panel to turn on the bus decoding bus menu. Select the FlexRay protocol and set bus display, independent window, display format, event list, tab, offset and decoding parameter.

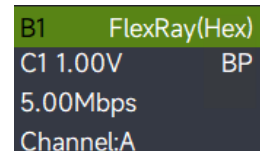

The Bus tab on the right bottom of screen will display the set value and state.

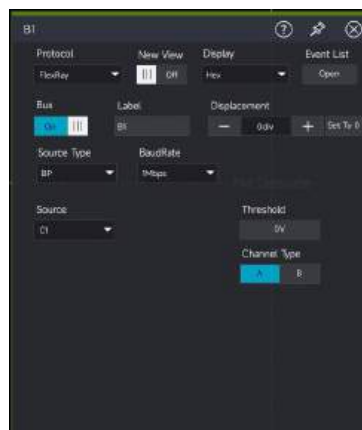

- Bus display: Set whether to turn on/off the decoding bus.

- Display format: Set the display format for the decoding bus, which can set to hexadecimal, decimal, binary system, ASCII or Auto.
- Event list: The event list displays the decoded data, corresponding line number, time, data, and verified data on the data line in a table format, making it easy to observe longer decoded data.
- Tab: Set the tab name of bus, it will display on the bus signal after the setting is completed, making it easy to distinguish between different bus types.
- Offset: Adjust the bus display position by **-** and **+** the range is -5.5~5.5div.

(2) Source type: Set the source type of FlexRay. It can set BP (bus negative), BM (bus positive).

(3) Signal rate: Set the transmission rate of FlexRay. It can set to 1Mbps, 5Mbps, 10Mbps or user-defined.

(4) Channel type: It can set A and B.



6.8 AudioBus

Full name of I²S is Inter-IC Sound or Integrated Interchip Sound, called IIS for short. It is a bus standard developed by Philips Semiconductors (now NXP Semiconductors) for audio data transmission between digital audio devices. The bus is designed for data transfer between audio devices and is widely used in various multimedia systems.

Depending on the position of SD relative to SCK and WS, I²S has three different operation modes, I²S, left-justified mode, right-justified mode.

Standard I²S mode

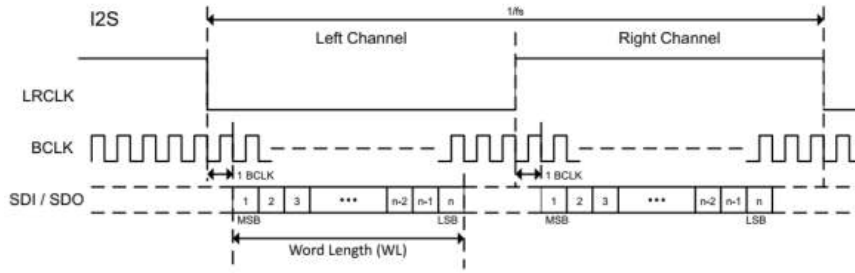

Left-justified mode (LJ): Transmission of data begins at the same time as the LRCLK is flipped. This standard is rarely used.

Note: When LRCLK is 1, the left audio channel data is transmitted, which is the opposite of the I²S Philips standard.

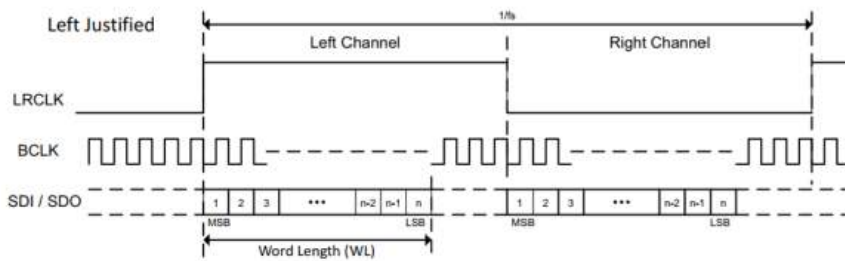

Right-justified mode (RJ): At the same time that the LSB of the sound data is transmitted, the LRCLK is flipped a second time (it just so happens that the LSB and LRCLK are right-aligned, so it called right-justified standard).

Note: When LRCLK is 1, the left sound channel data is transmitted, which is the opposite of the I²S Philips standard.

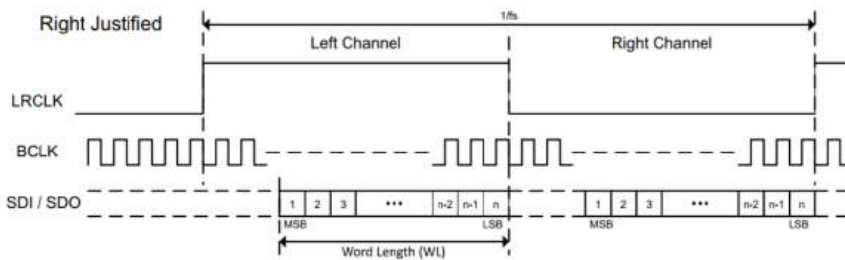

TDM (Time-division multiplexing)

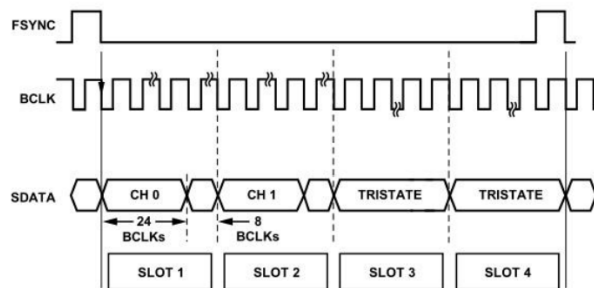

AudioBus Decoding Setup

(1) Bus+

Clicking Bus+ on the right bottom of screen or press the **Bus** key in Vertical control area on the front panel to turn on the bus decoding bus menu. Select the AudioBus protocol and set bus display, independent window, display format, event list, tab, offset and decoding parameter. The Bus tab on the right bottom of screen will display the set value and state.



- Bus display: Set whether to turn on/off the decoding bus.
- Display format: Set the display format for the decoding bus, which can set to hexadecimal, decimal, binary system, ASCII or Auto.
- Event list: The event list displays the decoded data, corresponding line number, time, data, and verified data on the data line in a table format, making it easy to observe longer decoded data.
- Tab: Set the tab name of bus, it will display on the bus signal after the setting is completed, making it easy to distinguish between different bus types.
- Offset: Adjust the bus display position by **-** and **+** the range is -5.5~5.5div.

(2) Protocol type: I²S, LJ (left-justified), RJ (right-justified), TDM.

(3) I²S signal setting includes connect the oscilloscope to chip selection (WS), serial clock (CLK) and serial data signal (SDO), then set the threshold level of each input channel, and finally setup the other signal parameters. The procedure for specifying the source and threshold level of the signal is similar to [“6.2 I²C”](#).

(4) Word selection polarity: positive polarity, negative polarity.

(5) Clock feature

Clock signal (CLK) should specify the valid clock edge.

- Rising edge – the data will be locked and saved at the rising edge of clock signal

- Falling edge – the data will be locked and saved at the falling edge of clock signal

(6) Specify the number of sound channel, clock and data bits.

Chip selection (WS) signal should specify the number of sound channel, clock number of each channel, data bits of each channel.

(7) Chip selection (WS) signal should specify the sound channel type

Left sound channel or right sound channel: Specify the sound channel to left sound channel or right sound channel.

Left sound channel: Specify the sound channel to left sound channel.

Right sound channel: Specify the sound channel to right sound channel

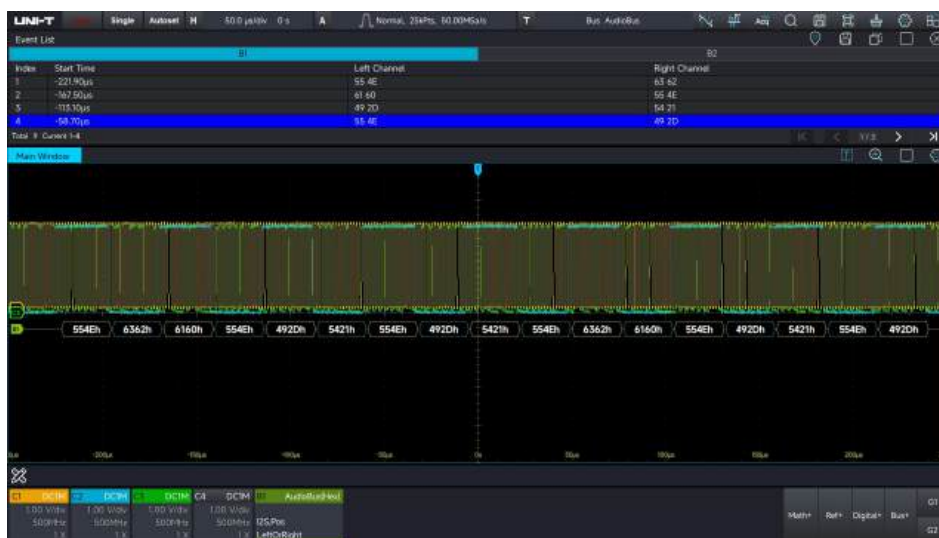

6.9 MIL-STD-1553

MIL-STD-1553 is a military standard issued by the U.S. Department of Defense, which defines the functional characteristics of mechanical, electrical, and serial data bus. The MIL-STD-1553B bus standard is widely used in the fields of integrated avionics systems for airplanes, armored vehicles, and ships. Generally, the transmission speed of 1553B bus is 1 Mbps, and there are also 4 Mbps using Manchester II code.

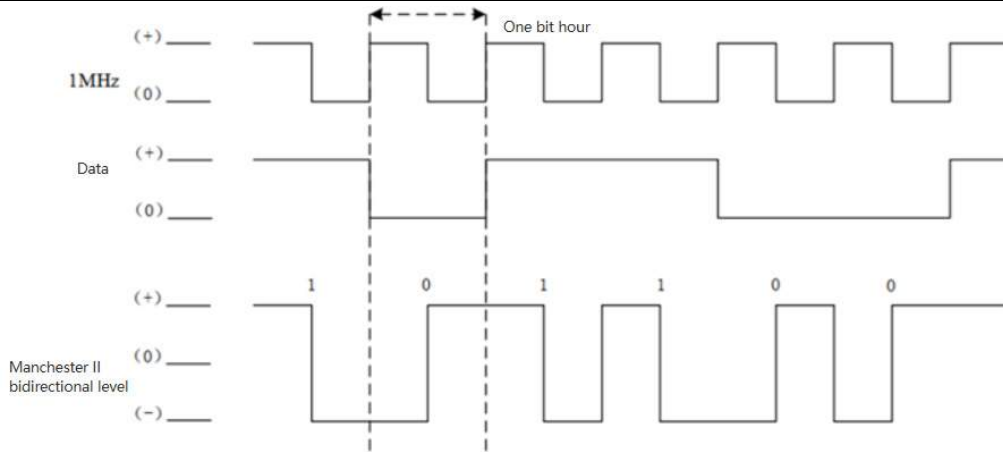

The MIL-STD-1553 message stream consists of a string of 1553B messages, the 1553B message consists of a command word, a data word, and a state word. The minimum unit of 1553B message is bit, with every 20 bits forming a word, and each word has a valid information bit of 16 bits. The valid information bit is preceded by a 3-bit synchronization header (the synchronization header is divided into 2 one-and-a-half bits) and followed by a 1-bit parity bit (odd parity is used).

(1) Command word

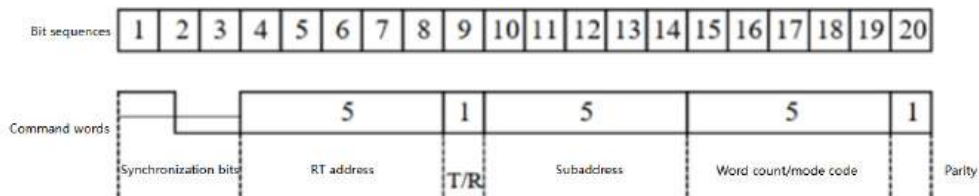

(2) Data word

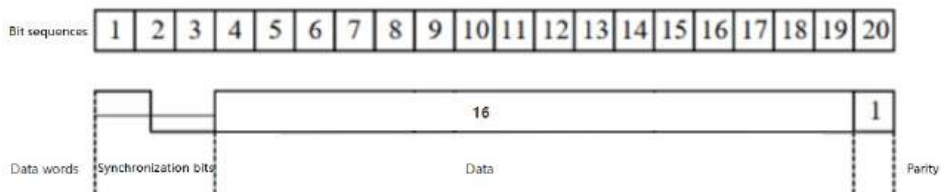

(3) State word

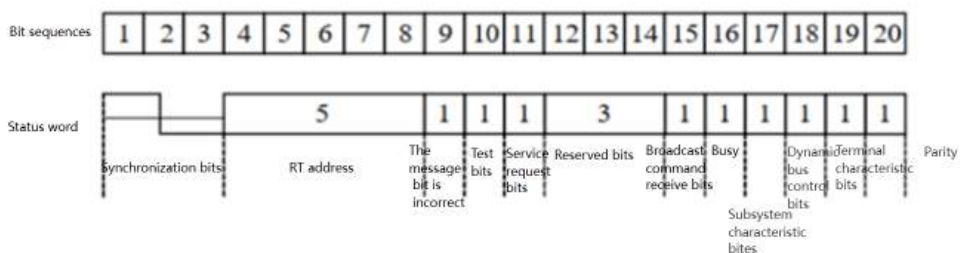

MIL-STD-1553 Decoding Setup

(1) Bus+

Clicking Bus+ on the right bottom of screen or press the **Bus** key in Vertical control area on the front panel to turn on the bus decoding bus menu. Select the MIL protocol and set bus display, independent window, display format, event list, tab, offset and decoding parameter.

B1	MIL(Hex)
C1	3.00V 1.00V
	1.00Mbps
	Positive

The Bus tab on the right bottom of screen will display the set value and state.

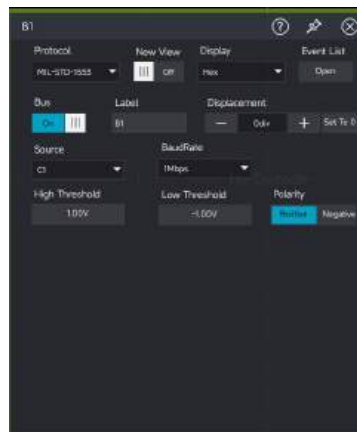

- Bus display: Set whether to turn on/off the decoding bus.
- Display format: Set the display format for the decoding bus, which can set to hexadecimal, decimal, binary system, ASCII or Auto.
- Event list: The event list displays the decoded data, corresponding line number, time, data, and verified data on the data line in a table format, making it easy to observe longer decoded data.
- Tab: Set the tab name of bus, it will display on the bus signal after the setting is completed, making it easy to distinguish between different bus types.
- Offset: Adjust the bus display position by **-** and **+** the range is -5.5~5.5div.

(2) Source: C1~C4 can be the signal input for MIL-STD-1553.

(3) Baud rate: Set the transmission rate of signal, it can set to 1 Mbps, 10 Mbps or user-defined.

(4) Set high-low level threshold

(5) Data polarity: Positive polarity, negative polarity

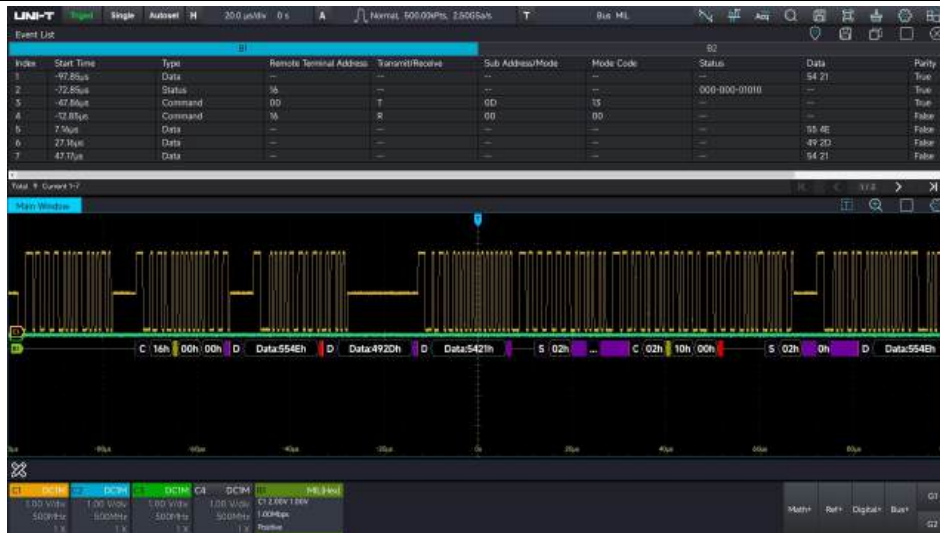

6.10 ARINC429

ARINC429 bus protocol is proposed and approved by the U.S. Airlines Engineering Committee (Airlines Engineering Committee) in July 1977. ARINC is the abbreviation of the Aeronautical Radio Incorporated. The full name is Digital Information Transfer System (DITS). The protocol standard specifies the requirements for digital information transfer between avionics and related systems, and is widely used in advanced civil airliners.

ARINC429 bus adopts shielded twisted pair cable, with simple structure, stable performance and strong anti-interference. It is a unidirectional data bus, which means it can only receive data in one direction. Information can only be output from the transmitting port of the communication device, through the transmission bus to the interface with it connected to other devices that need the information. When a bidirectional transmission is required between two communication devices, a separate transmission bus is used for each direction.

ARINC429 transmission rate: Slow speed of 12.5kb/s, high speed of 100kb/s. The high speed and slow speed cannot be transmitted on the same transmission bus.

Threshold voltage: ARINC429 uses high level of + 5V, low level of -5V; there is 0V between + 5V and - 5V, which is Null. It adopts bipolar zero clearing tri-state code modulation, the modulating signal has three level states: “high”, “zero” and “low”.

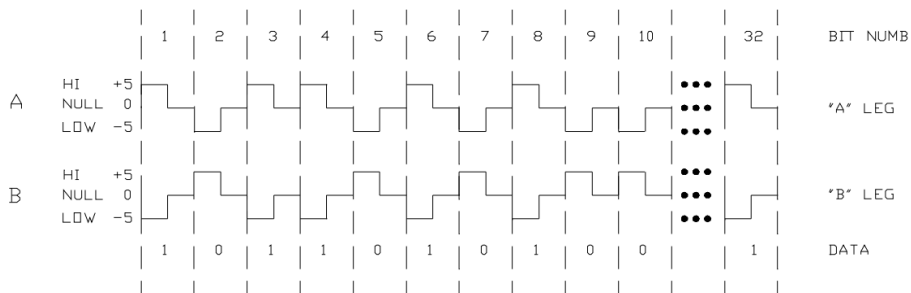

In protocol layer, a data package transmits data of 32 bits, LSB at first and then MSB.

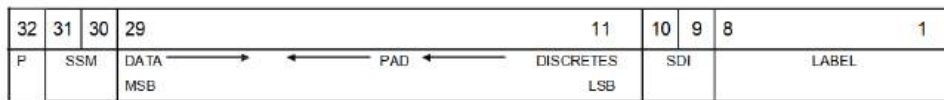

Bit 1~bit 8: Tab domain indicates data type. This data type refer to the transmitted data is related to which subsystem on the vehicle.

Bit 9~bit 10: SDI indicates data destination or more commonly the data source.

Bit 11~bit 29: Data domain is expressed as BCD code or BNR code, this two code format can be mixed use.

Bit 30~bit 31: SSM (Signal/Status Matrix) describes the data character in a transmission.

Bit 32: P, parity check bit, ARINC429 uses odd parity check. The checking method is to display "1" in bit 32 when the sum of the number of bits (i.e., the number of 1) appearing high from bit 1 to bit 31 is an even number. If it is an odd number, "0" is displayed.

ARINC429 Decoding Setup

(1) Bus+:

Clicking Bus+ on the right bottom of screen or press the **Bus** key in Vertical control area on the front panel to turn on the bus decoding bus menu. Select the ARINC429 protocol and set bus display, independent window, display format, event list, tab, offset and decoding parameter. The Bus tab on the right bottom of screen will display the set value and state.



- Bus display: Set whether to turn on/off the decoding bus.
- Display format: Set the display format for the decoding bus, which can set to hexadecimal, decimal, binary system, ASCII or Auto.

- Event list: The event list displays the decoded data, corresponding line number, time, data, and verified data on the data line in a table format, making it easy to observe longer decoded data.
- Tab: Set the tab name of bus, it will display on the bus signal after the setting is completed, making it easy to distinguish between different bus types.
- Offset: Adjust the bus display position by **-** and **+** the range is -5.5~5.5div.

(2) Source: C1~C4

(3) Signal rate: 12.5 kbps, 100 kbps and user-defined.

(4) Set high-low level threshold: ARINC429 has tri-state of “high”, “zero”, “low”, so the high-low level threshold need to be set.

(5) Decoding mode: 19-bit: data, 21-bit: data +SDI, 23-bit: data+SDI+SSM.

(6) Polarity: positive polarity, negative polarity.

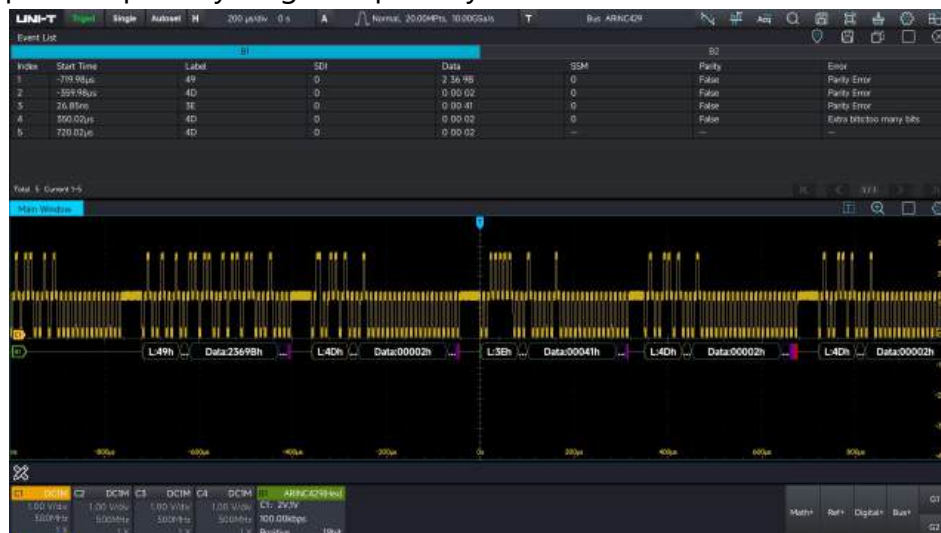

6.11 SENT

SENT (Single Edge Nibble Transmission) is a point-to-point, unidirectional transmission scheme introduced by SAE, and is used for data transmission between vehicle sensors and electronic control units (ECU).

Level requirement of SENT high/low signal: Level requirement of high/low signal: 0~0.5V for logic level 0, 4.1~5V for logic level 1.

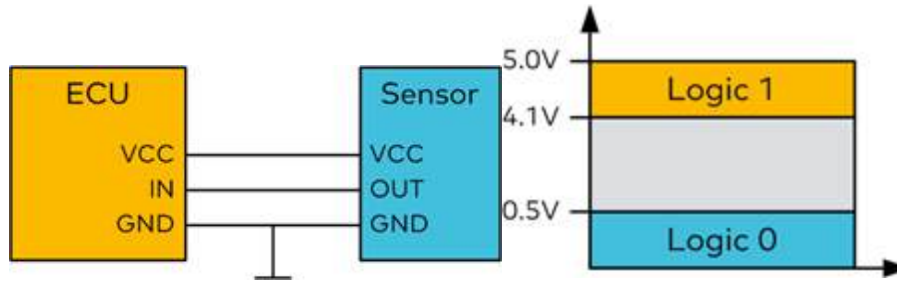

Data of SENT protocol takes a half-byte nibble, i.e., 4 bits for code definition, and a half-byte nibble is defined by the time difference between two falling edges.

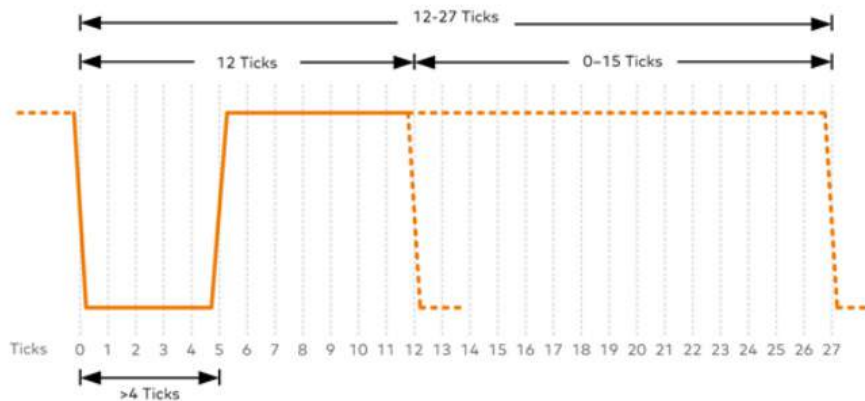

Frame Structure

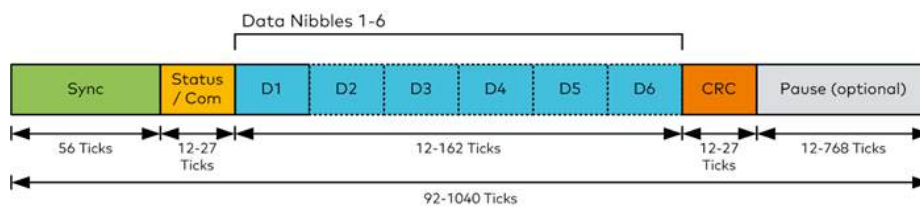

SENT protocol is encoded with Nibble as the base unit; its basic component as flows.

- Sync is synchronous pulse, the number is fixed 56 Ticks
- Status/Com is state and communication state, the number is 12~27 Ticks, that is 1 Nibble (4bit)
- Data is data filed, 12~162 Ticks, that is 1~6 Nibble
- CRC is check filed, 12~27 Ticks, that is 1 Nibble
- Pause pulse, the number is 12~768 Ticks. Earlier SENT protocols did not have this field or a fixed length Ticks, after SENT2010, part of this feature can be dynamically conditioned on the number of Ticks, realizing that the entire SENT protocol is the same fixed length Ticks.

SENT Decoding Setup

(1) Bus+:

Clicking Bus+ on the right bottom of screen or press the **Bus** key in Vertical control area on the front panel to turn on the bus decoding bus menu. Select the SENT protocol and set bus display, independent window, display format, event list, tab, offset and decoding parameter.

The Bus tab on the right bottom of screen will display the set value and state.

B1	SENT(Hex)
C1 1.00V	Pos
3µs 20%	Pause
Fast Channel	6



- Bus display: Set whether to turn on/off the decoding bus.
- Display format: Set the display format for the decoding bus, which can set to hexadecimal, decimal, binary system, ASCII or Auto.
- Event list: The event list displays the decoded data, corresponding line number, time, data, and verified data on the data line in a table format, making it easy to observe longer decoded data.
- Tab: Set the tab name of bus, it will display on the bus signal after the setting is completed, making it easy to distinguish between different bus types.
- Offset: Adjust the bus display position by **-** and **+** the range is -5.5~5.5div.

(2) Signal input: C1~C4.

(3) Signal polarity: positive/negative.

(4) Threshold level: Used to distinguish logic "1" and "0".

(5) Clock period: 1us, 3us, 10us, 30us, 100us, 300us and user-defined.

(6) Clock tolerance: The adjustable range is 1% - 30%.

(7) Mode: Fast channel, Slow channel.

(8) Data length: 1 Nibbles, 2 Nibbles, 3 Nibbles, 4 Nibbles, 5 Nibbles, 6 Nibbles.

(9) Pause bit: YES/NO.

(9) Data segment format: Nibble, Fast Channel.



7. Automatic Measurement







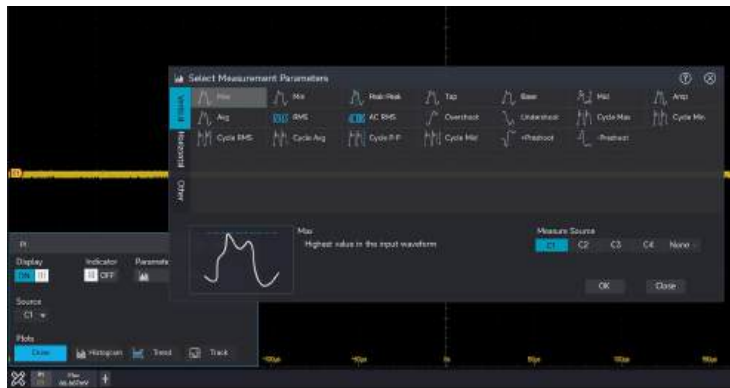

- [Parameter Measurement](#)
- [Parameter Snapshot](#)
- [Add Measurement Parameter](#)
- [Measurement Statistics](#)
- [Threshold Measurement](#)

7.1 Parameter Measurement

MSO8000HD series oscilloscope can automatically measure 52 kinds of parameter, such as vertical, horizontal and other parameter.



Vertical Parameter

-  Maximum (Max): The voltage from the highest point of the waveform to GND.
-  Minimum (Min): The voltage from the lowest point of the waveform to GND.
-  Peak-to-peak (Pk-Pk): The voltage value from the highest point to the lowest point of the waveform.
-  High: The voltage value from the flat top of the waveform to GND.
-  Low: The voltage value from the bottom of the waveform to GND.
-  Middle: Half of the sum of the voltage values at the top and bottom of the waveform
-  Amplitude (Amp): The voltage from top to bottom of the waveform.
-  Average (Mean): The average amplitude of the waveform in the screen.
-  Root mean square (RMS): The energy generated by the conversion of AC signal, it corresponds to the DC voltage that generates equivalent energy.



Standard deviation (AC RMS): The RMS value is the waveform which DC component has removed.



Positive overshoot (+OverSht): The difference between the maximum and the highest value is divided by the amplitude.



Negative overshoot (-OverSht): The difference between the minimum and the lowest value is divided by the amplitude.



Maximum of cycle (CycMax): The maximum value of waveform in one cycle



Minimum of cycle (CycMin): The minimum value of waveform in one cycle



RMS of period (CycRMS): The energy generated by the conversion of AC signal in one cycle, it corresponds to the DC voltage that generates equivalent energy.



Average of cycle (CycMean): The average amplitude of waveform in one cycle



Peak-to-peak of cycle (CycPK-PK): The peak-to-peak of waveform in one cycle



Middle of cycle (CycMid): The middle of waveform in one cycle



Positive overshoot (+PreSht): Preshoot before the rising edge



Negative overshoot (-PreSht): Preshoot before the falling edge

Horizontal Parameter



Period: Time between two consecutive, same-polarity edges of a repetitive waveform.



Frequency : The reciprocal of the cycle



Rise time: Time needed for waveform amplitude rising from 10% to 90%.



Fall time: Time needed for waveform amplitude falling from 90% to 10%.



+ Pulse Width: The pulse width of a positive pulse at amplitude of 50%.



- Pulse Width: The pulse width of a negative pulse at amplitude of 50%.



+ duty cycle: The ratio of positive pulse width to cycle.



- duty cycle : The ratio of negative pulse width to cycle.



Time @Max: The point corresponding to the first maximum



Time @Min: The point corresponding to the first minimum



Rise time @Lv: Rising edge duration between user-defined levels.



Fall time @Lv: Falling edge duration between user-defined levels.



Period @Lv: The time for each cycle at the specified level of the waveform.



Frequency @Lv: The frequency for each cycle at the specified level.



Pulse width @Lv: The width measured at the specified level of the waveform



Duty cycle @Lv: The duty ratio of the specified position.



Δ Phase @Lv: Calculating the phase difference at 50% of the first rising edge between the two waveforms.



RRD@Lv: Calculating the time difference at the specified level of the first rising edge between the two waveforms.



FFD@Lv: Calculating the time difference at the specified level of the first falling edge between the two waveforms.



RFD@Lv: Calculating the time difference at the specified level from the rising edge of the first waveform to the falling edge of the second waveform.



FRD@Lv: Calculating the time difference at the specified level from the falling edge of the first waveform to the rising edge of the second waveform.



Skew: Calculating the time difference from the first edge of 50% to the system trigger position.



Data points: The number of sample points of the waveform data participating in the measurement.



Cycle num: The cycle number within the periodic waveform.



Rise edge num: The number of rising edges within the waveform area.



Fall edge num: The number of falling edges within the waveform area.



Pos pulse num: The number of positive pulses within the waveform area.



Neg pulse num: The number of negative pulses within the waveform area.



Setup time: Time from exceeding the specified intermediate reference level on the data source to the recently exceeding the specified intermediate reference level on the clock source.



Hold time: Time from exceeding the specified intermediate reference level on the clock

source to the recently exceeding the specified intermediate reference level on the data source.

Other Parameter

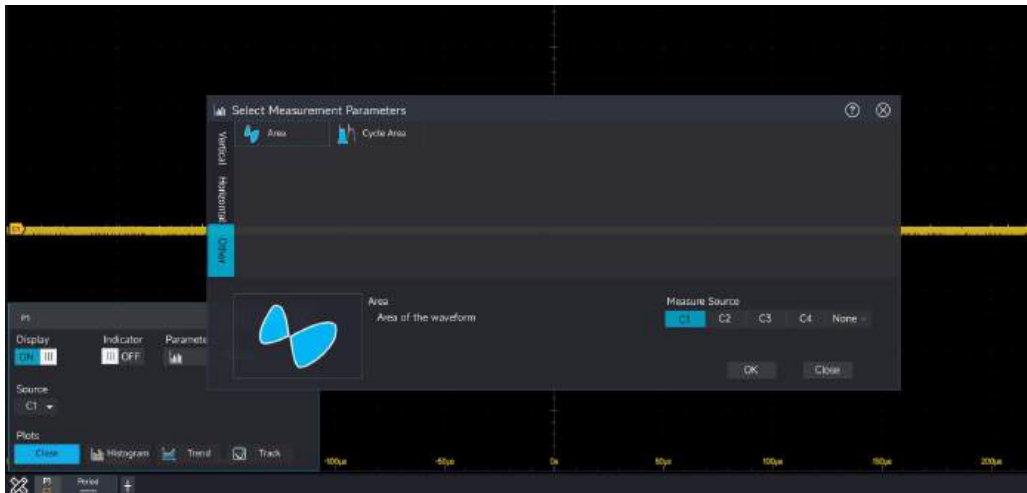

Area: Algebraic sum of all point voltage and time product on the screen.



Cycle area: Algebraic sum of all point voltage and time product in one cycle of waveform.

7.2 Parameter Snapshot

Press the **Quick Meas** key to open this function to check the result of all parameter measurement. Or click the icon of measurement bar  to enable this function.

The parameter snapshot is always marked with a color consistent with the current measurement channel (the primary source).

If it displays “----”, indicating no signal input connect to the current measurement source or the measured result is not within the valid range (too large or too small).



7.3 Add Measurement Parameter

MSO8000HD supports the user to select interested parameter for long time observation. Click the measurement icon  in the lower left corner to open the parameter measurement.

Restore to the previous measured parameter by default. Click the icon  to enter the parameter measurement page, click the “parameter” to be observed. The measurement parameter can select “Vertical”, “Horizontal” and “Other”. The selected parameter is marked with blue dashed box, click “Select” to add or change to modify the measurement parameter. When it added, the real-time measured value of the parameter will be displayed in the lower left corner, and the added parameter can be used for the next step, such as measurement statistics or histogram, tendency chart analysis. The parameter that have already been added cannot be added repeatedly.



7.4 Measurement Statistics

MSO8000HD calculates and analyzes the currently added measurement parameters in real time according to the number of samples. Click the measurement icon  in the lower left corner to open the measurement statistics. It supports the maximum, the minimum, average, standard deviation and sample statistics.



7.5 Threshold Measurement

MSO8000HD allows the user to limit the test range when using the automatic parameter measurement.

Threshold Measurement-screen: indicates that the current parameter measurement range uses the entire screen as the measurement domain.

Threshold Measurement-cursor: indicates that the current parameter measurement range uses the sample within the cursor as the measurement domain.



7.6 Measure Operations

When two or more measurement parameters are turned on, addition, subtraction, multiplication, and division operations on these measurement parameters are supported. Measurement operations are only performed on numerical values, regardless of the type and unit of the measurement items.



7.7 Reset Statistics

Selecting "Reset statistics" can reset the statistics of all added measurement items. This is effective when the statistics function is turned on.



7.8 Delete Measure





Selecting "Delete measure" allows you to delete all the added measurement parameters with one click. Once deleted, the original measurement items will not be restored when you open the parameter measurement again.



8. Cursor Measurement

- [Time-domain Cursor](#)
- [Frequency-domain Cursor](#)

Press the **Cursors** key on the front panel or click the icon  in the top right corner to enter the cursor measurement.

- (1) Display: “ON” indicates the cursor measurement is enabled. “OFF” indicates the cursor measurement is disabled.
- (2) Source: C1, C2, C3, C4, Math, Ref
- (3) Type: Horizontal indicates the measured result of time/frequency. Vertical indicates the measured result of voltage/power.
- (4) A position: The position of cursor A in the screen, with unit of div. It can adjust by rotating rotary knob in Function area on the front panel or clicking  and  to adjust the A’s position in the cursor measurement window or clicking A’s position to pop out the numeric keyboard to adjust.
- (5) B position: The position of cursor B in the screen, with unit of div. It can adjust by rotating rotary knob in Function area on the front panel or clicking  and  to adjust the B’s position in the cursor measurement window or clicking B’s position to pop out the numeric keyboard to adjust.
- (6) Data display: Suspend or fixed.
- (7) Waveform Tracking: Waveform tracking is turned off by default. Adjusting the vertical or horizontal scale of the waveform will not affect the cursor position. After enabling waveform tracking, when adjusting the vertical scale or vertical position, the horizontal cursor moves along with the waveform. When adjusting the horizontal scale or horizontal position, the vertical cursor moves along with the waveform.
- (8) Synchronous movement: This function is disabled by default. Moving cursor A or cursor B will not affect the position of the other cursor. When synchronous movement is enabled, an icon  will appear next to B, moving cursor B, cursor A will follow the movement to keep the relative distance. Moving cursor A, cursor B will not be affected.
- (9) Position display: Absolute value or relative value.

Absolute value: The actual unit of the vertical/horizontal coordinate is used as the unit of the measurement result.

Relative value: Taking the 0 scale of the vertical/horizontal coordinate as the standard, and

using div as the measurement unit.

(10) Horizontal unit: s, %

(11) Vertical unit: s, °, %



8.1 Time-domain Cursor

Source: C1~C4, Math, REF

Vertical Measurement

Select the cursor type to “Vertical” in the cursor measurement menu.

“X” indicates the measured result of channel time.

“Y” indicates the measured result of voltage at the intersection of the open channel and the cursor.

“ ΔX ” indicates the absolute value of the time difference measured by the two cursors A-B.

“ ΔY ” indicates the absolute value of the voltage difference measured by the two cursors A-B.

“ $1/\Delta X$ ” indicates the reciprocal of the time difference measured by the two cursors A-B (indicating the waveform frequency between the two cursors A-B).

“ $\Delta Y/\Delta X$ ” indicates the absolute value of voltage variation at two points A-B in unit interval.

Horizontal Measurement

Select the cursor type to “Horizontal” in the cursor measurement menu.

“Y” indicates the measured result of cursor voltage.

“ ΔY ” indicates the absolute value of the voltage difference measured by the two cursors A-B.

Vertical & Horizontal Measurement

In the cursor function menu, select the cursor type "Horizontal & Vertical".

The Vertical & Horizontal cursor measurement is a combination of horizontal measurement and vertical measurement, and it can measure horizontal and vertical parameters simultaneously.

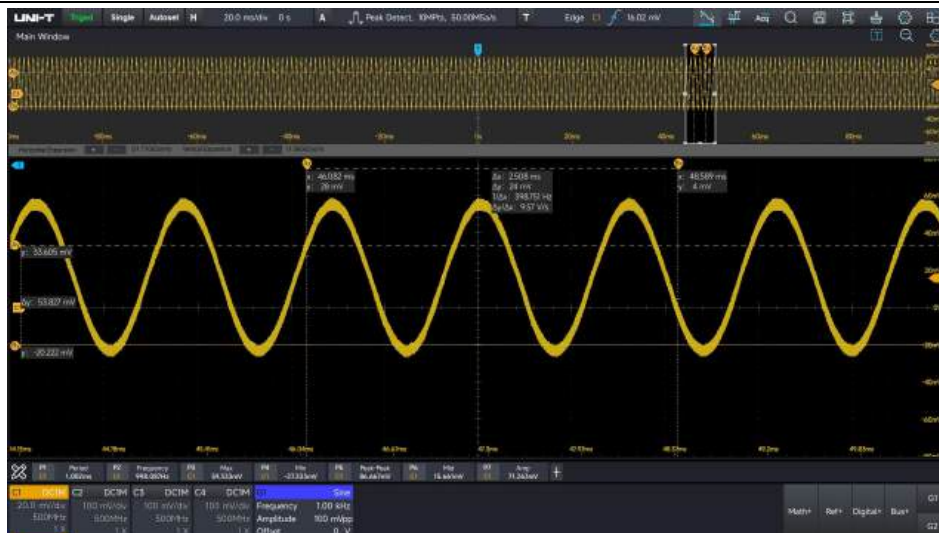

8.2 Frequency-domain Cursor

Source: Math

Vertical Measurement

Select the cursor type to “Vertical” in the cursor measurement menu.

Magnitude spectrum

“X” indicates the measured result of channel frequency.

“Y” indicates the measured result of amplitude/power at the frequency intersection of the open channel and the cursor.

“ ΔX ” indicates the absolute value of the frequency difference measured by the two cursors A-B.

“ ΔY ” indicates the absolute value of the amplitude/power difference measured by the two cursors A-B.

“ $1/\Delta X$ ” indicates the reciprocal of the frequency difference measured by the two cursors A-B (indicating the time difference between the two cursors A-B).

“ $\Delta Y/\Delta X$ ” indicates the absolute value of amplitude/power variation at two points A-B in frequency interval.

Horizontal Measurement

Select the cursor type to “Horizontal” in the cursor measurement menu.

“Y” indicates the measured result of cursor amplitude/power

“ ΔY ” indicates the absolute value of the amplitude/power difference measured by the two cursors A-B.



Vertical & Horizontal Measurement

In the cursor function menu, select the cursor type "Horizontal & Vertical".

The vertical & horizontal cursor measurement combines horizontal measurement and vertical measurement, enabling the simultaneous measurement of horizontal and vertical parameters.

9. Mathematical Operation

- [Basic Operation](#)
- [FFT](#)
- [Filter](#)
- [ERes](#)
- [Advanced operation](#)
- [User-defined operation](#)

MSO8000HD series mixed signal oscilloscope carries a variety of mathematical operations, it includes basic operation, FFT, digital filter, advanced operation and user-defined.

Clicking the “Math +” tab to enter the mathematical operation function menu, the vertical scale, vertical position, horizontal scale and horizontal position of the math waveform can be set in the menu. The math waveform tab can also be set in the menu, the unit of mathematical operation can be customized.

Math operation cursor  marks the result of a mathematical operation.

9.1 Basic Operation

The waveform involved in the operation can be analog waveform, mathematical waveform, reference waveform. Mathematical operations can be performed on the channel waveforms with "+", "-", "x", and "÷" operations to obtain the final MATH waveform.

Operator: “+”, “-”, “x”, “÷”

1. +: The waveform of source 1 and source 2 are added point by point.
2. -: The waveform of source 1 and source 2 are subtracted point by point.
3. x: The waveform of source 1 and source 2 are multiplied point by point.
4. ÷: The waveform of source 1 and source 2 are divided point by point.

9.2 FFT

FFT (Fast Fourier Transform) operation can convert time-domain signal (YT) to frequency-domain

signal. The following types of signals can be easily observed by using FFT.

1. Harmonic content and distortion in measurement system
2. Noise feature in DC power supply
3. Vibration analysis

Vertical Unit

The unit of the FFT operation results.

Magnitude spectrum: **Vrms** and **dBm**

Vrms and **dBm** respectively display the vertical amplitude size in linear and decibel volts. If the FFT spectrum need to display in a large dynamic range, dBm is recommended.

Frequency Range

- Center frequency: Set the frequency for the center frequency point of the FFT spectrum view
- Span: Set the scanning range of FFT spectrum, the center frequency point is used as the reference, and the left and right bandwidths take each half of the span.

Count

The number of points processed by the FFT spectrum, it can set Num1k, Num2k, Num4k, Num8k, Num16k, Num32k, Num1M

Window

Window function, choose a suitable window function can reduce the problem of spectral leakage, so that the time-domain signal seems to better meet the periodicity of the FFT processing requirements (i.e., the window function is required to be as narrow as possible in the spectrum of the main flap, the side flap attenuation is as large as possible. However, the two cannot have both, so the window function should be selected according to the actual demand. The narrower the main flap, the higher the frequency recognition accuracy of the window function; the larger the side-valve attenuation of the window function, the higher the amplitude recognition accuracy).

Hamming, Blackman, Rectangle, Hanning, flat-top window can be selected for different measurement. The characteristics of window function and suitable for measuring different waveforms, so the user should select the window function according to the characteristics of the measured waveforms and the actual needs.

1. Rectangle: It has the best frequency resolution and the worst amplitude resolution, which is similar to the one with no window. It is suitable for measuring the following waveforms.

2. Hanning: Compared with the rectangle window, it has better frequency resolution, but poorer amplitude resolution. It is suitable for measuring sine, periodic and narrow-band random noise waveforms.
3. Hamming: The frequency resolution is slightly better than that of Hanning window. It is suitable for measuring transient or short pulse, and waveform in which the signal level varies considerably before and after.
4. Blackman: It has the best amplitude resolution, and the worst frequency resolution. It is suitable for measuring the single frequency signals or seeking higher harmonics.
5. Flat-top window: Accurate measurement signal, it is suitable for measuring the signal without precise reference substance but require accurate measurement.

Output Mode

- Magnitude spectrum
- Power spectrum
- Psd (power spectral density)
- Real part
- Imaginary part
- Phase spectrum

Display Mode

Open FFT default separate window, tap the icon  in the top right corner to display full screen.



FFT operative skill

The signal with DC component or deviations can cause errors or deviations in the FFT waveform components. To reduce the DC component, you can set the channel to AC coupling mode.

Peak Marker

Using touch gesture to tap the icon  in FFT window in top right corner to turn on the peak marker function.

(1) Select marker source

MSO8000HD supports 8 math channel open at the same time. The source can select M1-M8.

(2) Select threshold and number of marker

The threshold determines the display position of peak marker.

The number of marker determines how many peak can be marked. The marker range is 1~11.

(3) Select marker reading

Absolute value: Select the absolute value of marker

Increment: The absolute value of the frequency difference from the first marker to the second marker and the absolute value of the amplitude difference, and so on.

(4) Open automatic marker

When the automatic marker is enabled, the oscilloscope will mark the peak in real-time.



9.3 Filter

Filter Type

- Low-pass: Only signals with a source frequency lower than the current “cut-off frequency

1” are allowed to pass.

- High-pass: Only signals with a source frequency higher than the current “cut-off frequency 1” are allowed to pass.
- Band-pass: Only signals with a source frequency higher than the current “cut-off frequency 1” and lower than the current “cut-off frequency 2” are allowed to pass.
- Band-limited: Only signals with a source frequency lower than the current “cut-off frequency 1” or higher than the current “cut-off frequency 2” are allowed to pass.

Cut-off frequency 1

It can set by clicking  and  in the Math menu or input by the numeric keyboard.

Cut-off frequency 2

It can set by clicking  and  in the Math menu or input by the numeric keyboard.

In low/high pass, the cut-off frequency 2 is invalid and the menu will be hidden.

Caution: The range of cut-off frequency is related with the current horizontal time base.

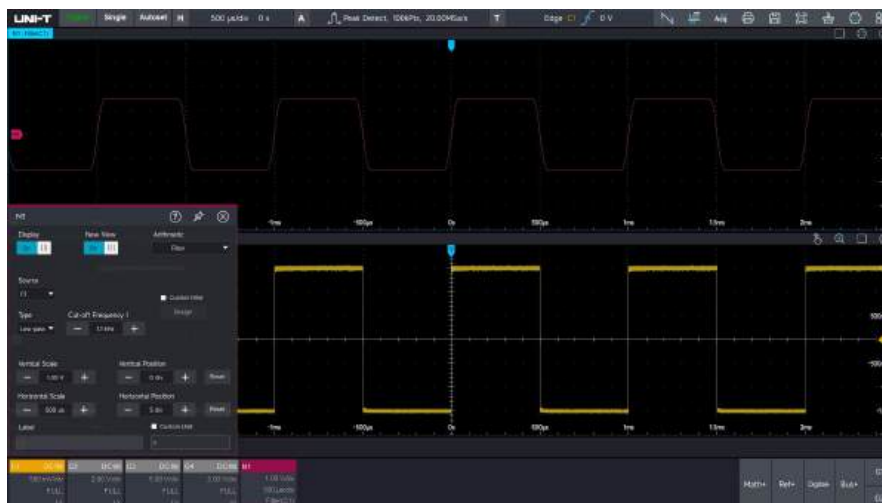

Custom Filter Designer

The MSO8000HD can be used for custom filter design, which includes FIR and IIR filter designers. In the filtering process, check the custom filter and click "Design" to open the custom filter designer.

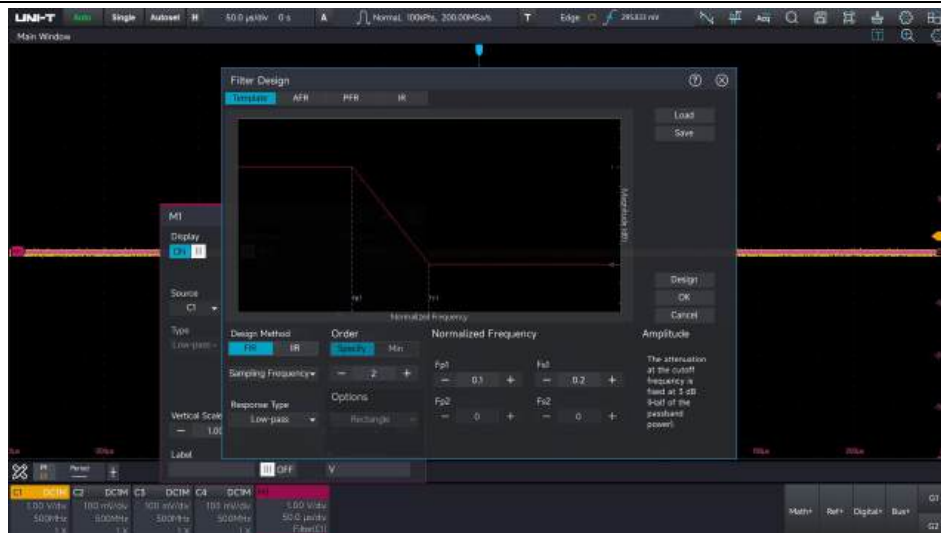

Brief introduction to the design interface:

- (1) Response types: There are designs such as low - pass, high - pass, band - pass, and band - stop.
- (2) Design methods: There are two major categories: IIR and FIR.
- (3) Filter order: The order can be set according to your needs. For FIR, the range is 2 - 50. For IIR, the range is 2 - 1000. For IIR, you can also directly select the minimum order.
- (4) Frequency parameters: Set according to the parameters you need.
- (5) Filter characteristics: Amplitude - frequency response, phase - frequency response, impulse response.

The following introduces the filter design parameters with an example:

- (1) Design a Butterworth low - pass filter.
- (2) The order is 10.
- (3) The sampling frequency is 500kHz.
- (4) The cut - off frequency is 50kHz.
- (5) According to the normalized frequency calculation formula: $f_p/f_s/2$, the normalized cut - off frequency coefficient is 0.2.

Set the parameters respectively according to the above steps, and then click "Design".

The template reference is as follows:

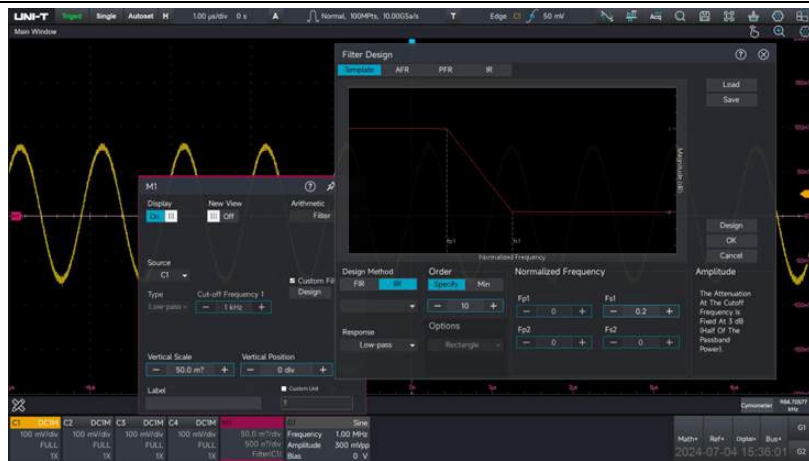

After the design is completed, you can view the characteristics of the designed filter.
Amplitude - frequency characteristic:



Phase - frequency characteristic:



Impulse response characteristic:



Click "OK" to apply the designed filter to waveform processing.

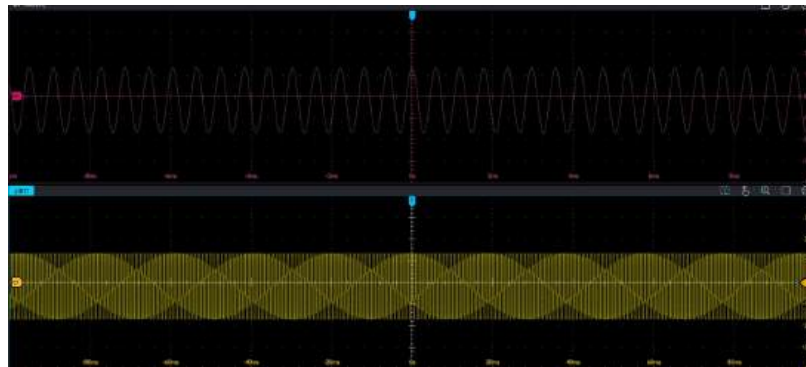

Filter design saving and loading:

You can click "Save" in the upper - right corner of the designer to save the filter designer as a script. When using it next time, click "Load" to call it.

9.4 Advanced Operation

MSO8000HD supports embedded Matlab program and data presentation, the programming results are run directly on the oscilloscope.

Running Matlab

In the Math menu, select "Advanced Operation", select the engine library type as "Matlab", click the code compiler to pop up the Matlab code compiler, connect to the keyboard, you can directly input the Matlab code or import the code, click "Run" once, you can get the programming result.

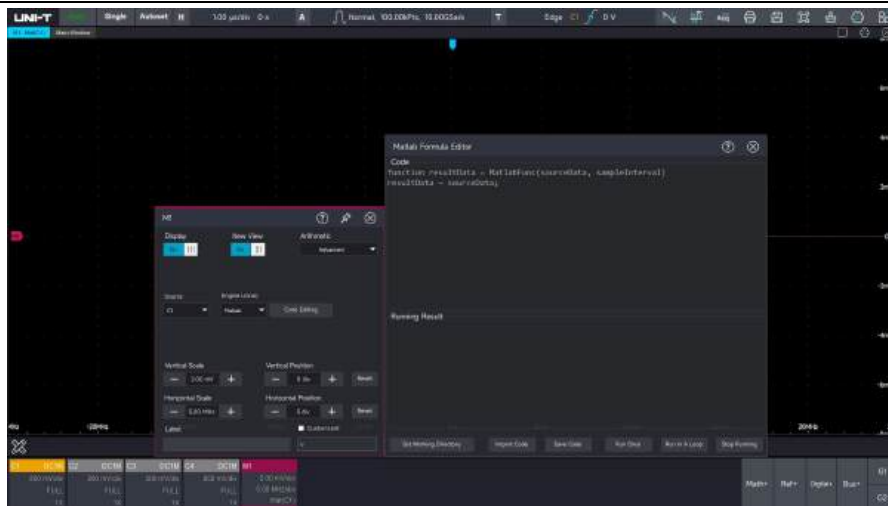

Set Working Directory

The default path for the code compiler to compile files, the level of the working directory can be adjusted by clicking “+” and “-”, click the “folder” to select the folder as the working folder of the compiler, and the working directory will be opened by default for saving code and importing code.

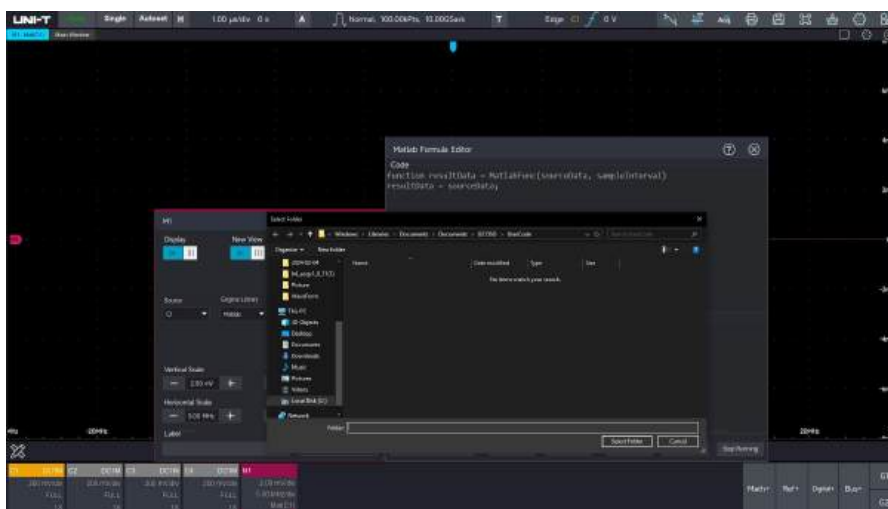

Import Matlab

Click “Import”, find the saved Matlab code file in the working directory with suffix “.m”, select it and click “Confirm” to load it into the code compiler. You can copy the file to the working directory in advance, or import it from other removable storage devices (e.g. USB flash disk).

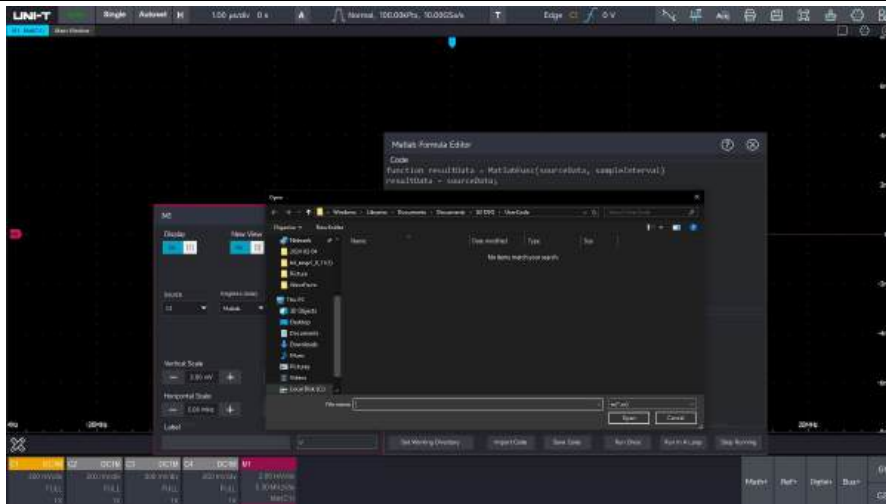

Save Matlab File

Create a blank .m file in the working directory in advance, and then click “Save” in the code compiler, and then select the created blank file to save it. The saved file can be recalled by importing the code.

9.5 User-defined Operation

The operation of each signal input channel can be freely to set to get the MATH waveform with different operation results. In the process of editing the expression, the user can “delete”, “clear”, “load” and “save” the expression. After applying the expression, the oscilloscope performs the operation according to the expression and displays the result. The following figure shows the result of five times averaging for the C1 channel.

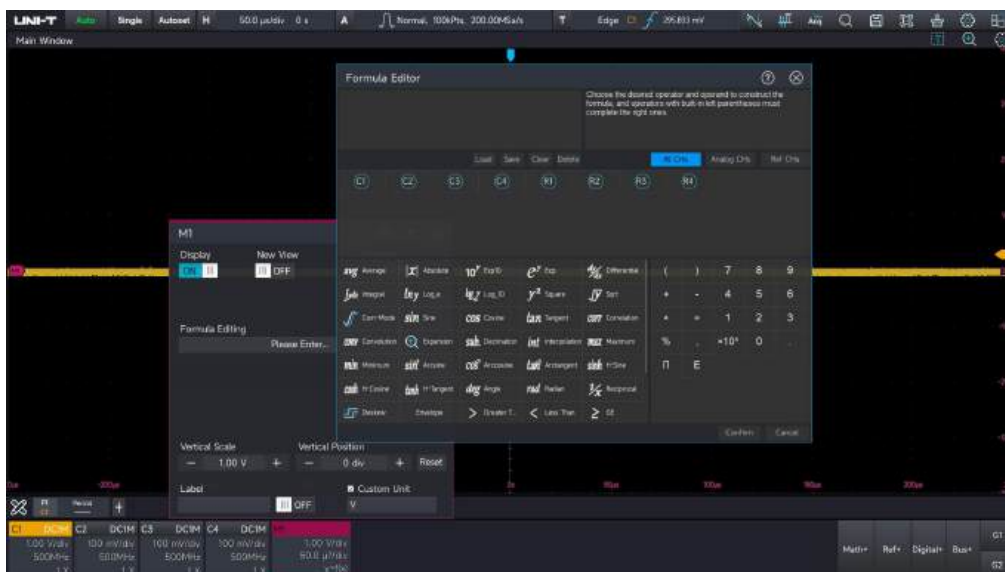

Select Channel

All channel: Four analog channels C1~C4, four-channel reference waveform R1~R4

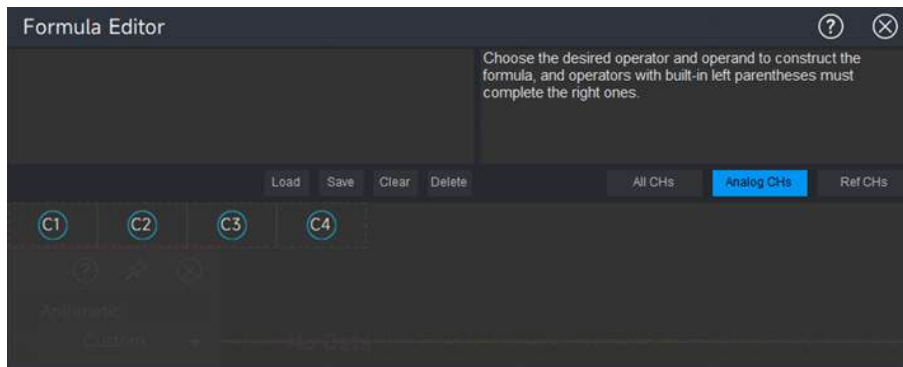

Analog channel: C1~C4

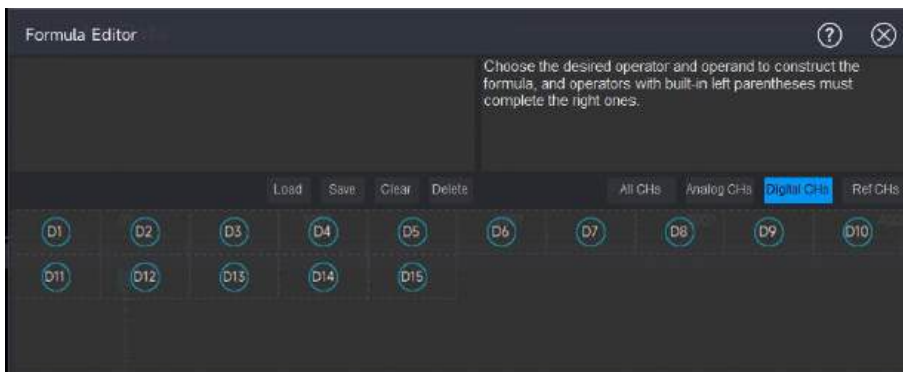

Reference channel: R1~R2

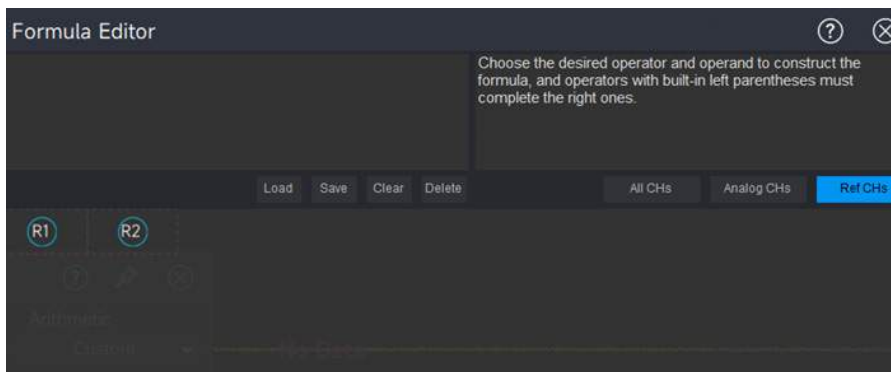

Formula Editing Area

When the expression is selected, a blue dashed box will appear, and the mathematical formula analysis of the expression and the definition of the variable will display in the expression dialog box. Please strictly follow the analysis requirements to enter the variable assignment, the calculation cannot carry out if the input is not met the requirement. Meanwhile, the oscilloscope will display the "Input format error".

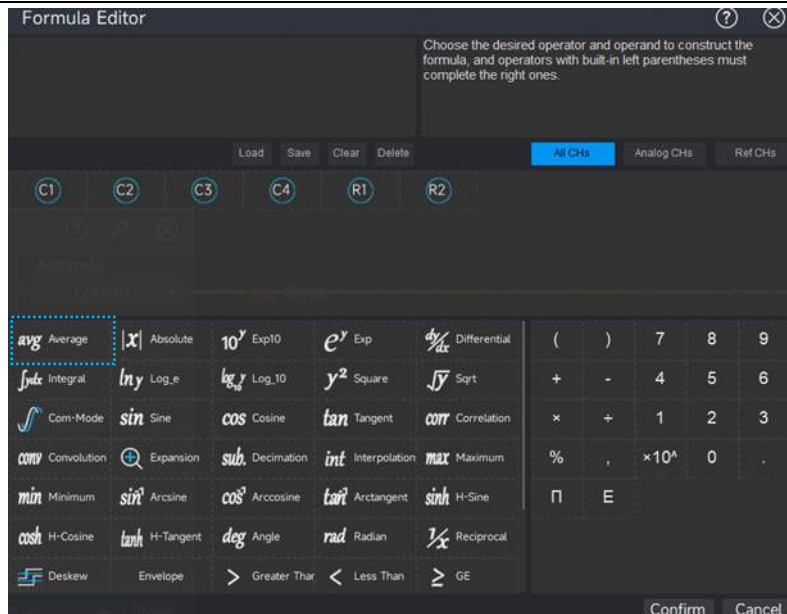

9.6 Multiple Windows

You can click the Math Channel menu and enable the independent window to start the independent window display for channels. Functions that can open independent windows include, but are not limited to, mathematical operations, reference waveforms, protocol analysis, digital channels, etc. After enabling the independent window, a corresponding horizontal dividing line will be added at the bottom, and the horizontal and vertical scales will also be displayed independently. You can adjust the window layout by using drag gestures. You can drag the window to a suitable position.



10. Reference Waveform

- [Open Reference Function](#)
- [Adjust Reference Waveform](#)
- [Close Reference Waveform](#)

MSO8000HD supports load the waveform file from internal system or external storage and supports load four reference waveforms to compare with the other waveform. Comparison and analysis of the differences between the two, in order to locate the cause of the failure.

10.1 Open Reference Function

Press the **Ref** key on the front panel or click “Reference +” in the lower right corner to open the reference waveform file, select the corresponding path and waveform file to load the reference waveform..

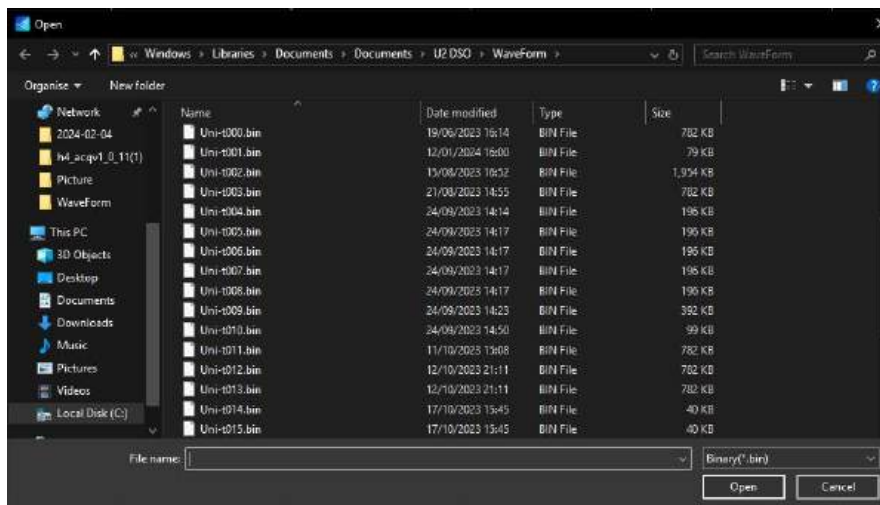

10.2 Adjust Reference Waveform

1. Open or close the display of the current reference waveform.
2. Set the current reference waveform to display in separate window.
3. Switch the reference waveform file.
4. Adjust the vertical scale and shift of reference waveform.
5. Adjust the horizontal scale and shift of reference waveform.
6. Add the tab for the current reference waveform.

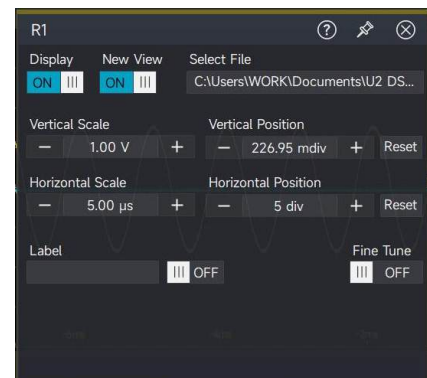

10.3 Close Reference Waveform

1. Close the display of the reference waveform, which is to delete the reference waveform.
2. Using touch gesture to sliding down the channel tab of reference waveform to close the reference waveform.

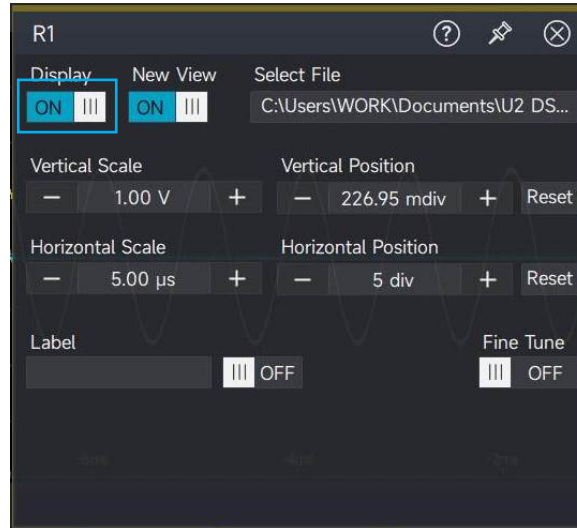

11. Pass/Fail Test

- [Limit Test](#)
- [Standard mask Test](#)

In the process of product design and production, it is often necessary to monitor the sudden change of the signal, or to determine whether the product is qualified. This oscilloscope has the pass/fail test function that can greatly complete this task.

By judging whether the input signal is within the template to determine the compliance of the signal, it can be used to find abnormal waveforms or conduct production line tests. The test results can be displayed on the screen or indicated by the pulse signal output from "AUX OUT" on the rear panel.

Test types: Limit test, Standard test

11.1 Limit Test

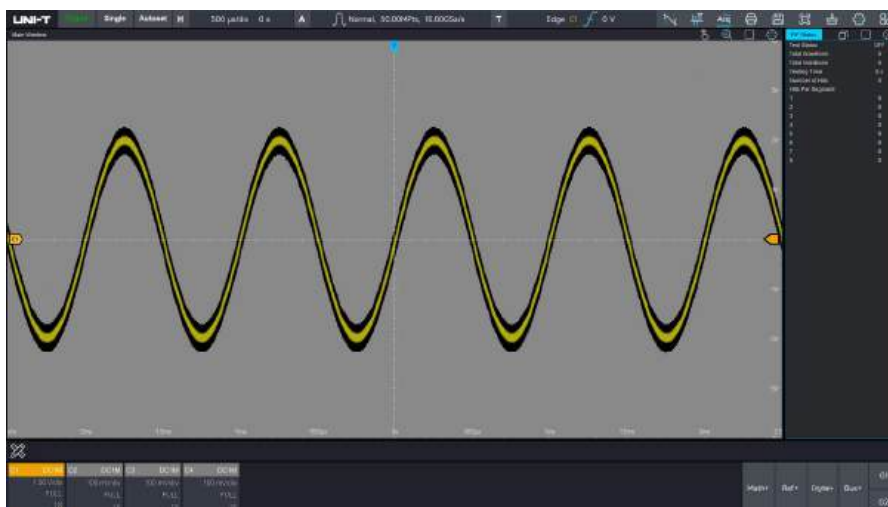

(1) Create template for limit test

Click start menu >P/F test > Pass/Fail test menu

1. Turn on/off test

2. Select the test source (C1~C4)

3. Select the test type – limit test

4. Set the template of limit test

- Select the reference source (C1~C4)
- Set the vertical tolerance (range: 1mdiv~1div)
- Set the horizontal tolerance (range: 1mdiv~500mdiv)
- Click “Create”

(2) Set the end condition of test

- Set the number of violation (range:1~1k)
- Select the total waveform and time of test
Allowable testing range of total waveform: 1~100k
Allowable testing range of total time: 100ms~1Ms

(3) Set the operation of fail test

Pulse: When the test fails, a pulse signal is sent from the rear panel Aux out.

Save: Save the waveform screenshot of failed test

Alarm: The alarm will be generated when detect the fail reach to the number of violation

Screen: Save the waveform screenshot of the failure.

(4) Set whether display the test template, indicates display the test template, indicates not display the test template.

(5) Click “Run”

(6) P/F state

P/F status bar displays the current test state (Running/OFF), the current total waveform, the number of violation, test time, number of target, and target number in each field.

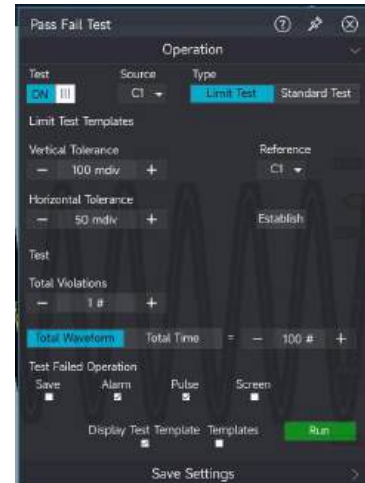



Caution: After the template condition is set, click “Running” to run the P/F template test, click “OFF” to end the operation.

11.2 Standard Mask test

(1) Create standard test template

Click start menu > P/F test > Pass/Fail test menu

1. Turn on/off test
2. Select the test source (C1~C4)
3. Select the test type – standard test
4. Select the standard: ANSI T1.102, ITU-T, and USB

(2) Set the end condition of test

- Set the number of violation (range:1~1k)
- Select the total waveform and time of test
Allowable testing range of total waveform: 1~100k
Allowable testing range of total time: 100ms~1Ms

(3) Set the operation of fail test: pulse, save, alarm and screen

(4) Set whether display the test template, indicates that display the test template, indicates that not display the test template.

(5) Click “Run”

(6) P/F state

P/F status bar displays the current test state (Running/OFF), the current total waveform, the number of violation, test time, number of target, and target number in each field.

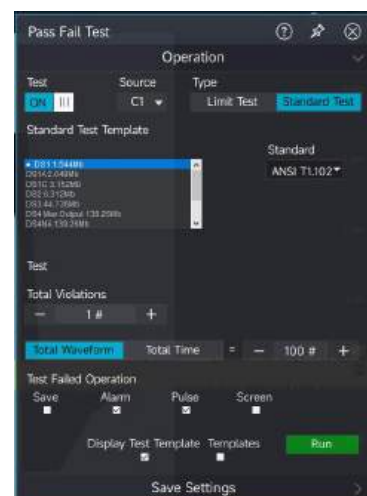



Caution: After the template condition is set, click “Running” to run the P/F template test, click “OFF” to end the operation.

11.3 Save Settings

- (1) Select the waveform saving format: Binary (.bin) and CSV (.csv) are supported.
- (2) Select the screenshot saving format: Bmp (.bmp), Png (.png) and Jpeg (.jpeg) are supported.
- (3) Select the save location.

Click the icon  to select the save location. If not set, the default save path will be used.

- (4) Enter the saved file name.

Click on the name to pop up the soft keyboard and enter the saved file name.

Date suffix: When saving, the current system date will be used to name the file. For example:

Uni-t00120231010163554902.bin

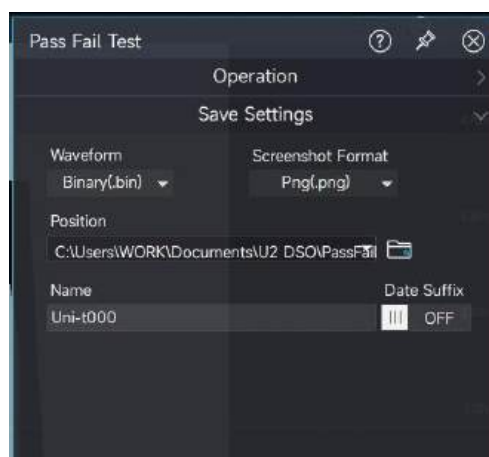

12. Digital Channel (Option)

- [Open/close the digital channel](#)
- [Chose the dogical channel](#)
- [Setting the waveform size](#)
- [Setting the threshold level and hysteresis](#)

MSO8000HD series mixed signal oscilloscope has equipped with 4 analog channels and 16 digital channels. For the digital channels, the oscilloscope compare the voltage obtained from each sample with a preset logic threshold. If the voltage of sampling point is greater than the threshold, it is saved as logic 1, otherwise, it is saved as logic 0. The oscilloscope displays the logic 1 and logic 0 in a graphical way for detecting and analyzing the error in circuit design (hardware and software design). This chapter is to describe how to use the digital channel of MSO8000HD.

Before using the digital channel, please use the accessory UT-M15 logic probe to connect the oscilloscope to DUT. For more detail about logic probe, refer to UT-M15 Logic Probe-User 's Manual.

12.1 Open/Close the digital channel

(1) Open digital channel

Press the **Digital** key in Vertical control area on the front panel or using touch gesture to tap the “logic +” in the lower right corner to turn on the digital channel.

(2) Close digital channel

Press the **Digital** key in Vertical control area on the front panel again or using touch gesture to sliding down the logic menu turn off the digital channel.

(3) When the digital channel is enabled, using touch gesture to tap the logic analyzer menu (blue part in the following figure) to open the logic menu.

C1	DC1M	C2	DC1M	C3	DC1M	C4	DC1M	Digital
	1.00 V/div		100 mV/div		100 mV/div		100 mV/div	0x000F
	FULL		FULL		FULL		FULL	
	1X		1X		1X		1X	

(4) Tick digital channel

The digital channel is tick four channels of D0-D3 by default. When the digital channel is open, the system prompts “The digital channel is open, analog channel is occupied”. The user can

freely tick any other channel, indicates that the channel has been activated, indicates that the channel is not activated. Click to select All to activate all digital channels, click to select Clear to delete all digital channels.

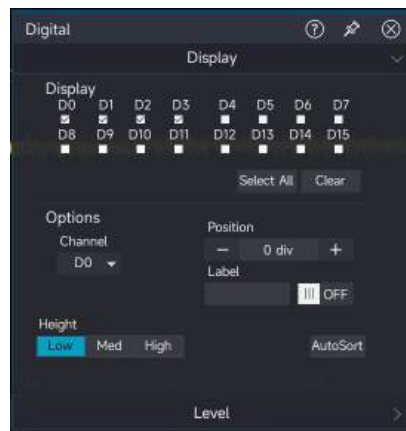

12.2 Chose the logical channel

- Using touch gesture to tap the waveform tab of digital channel to select the channel, the selected channel marked with red (only single channel can be selected). At this point, the waveform position can be changed by using touch gesture to sliding up/down, the position range is -4~3.5 div.

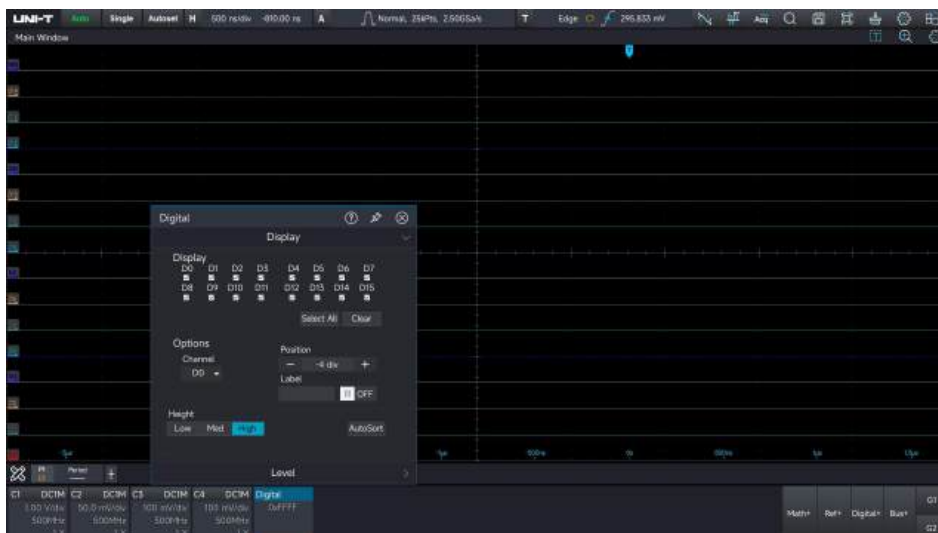

- Click the logic menu, the channel can also be selected in option > switch digital channel, clicking and to change the current channel's waveform position, the position range is -4~3.5 div.
- Set channel's tab: In logic menu, the channel's tab can be customized for distinguishing different channel.

12.3 Setting the waveform size

The waveform size can set to low, middle or high.

Caution: Each time you switch the waveform size, you need to click “Auto Sort” to make it effective.

12.4 Setting the threshold level and hysteresis

When the voltage of input signal is greater than the set threshold, it judges logic 1, otherwise, it is logic 0.

(1) Select level group

MSO8000HD supports 16-channel digital channel, it can select four level groups (D0~D3, D4~D7, D8~D11, D12~D15).

(2) Series

MSO8000HD supports a variety of series to set preset values: TTL, CMOS5000, CMOS3300, CMOS2500, ECL, PECL and LVDS. Each series has different preset values in conjunction with common standards, and user-defined threshold level and hysteresis can also be set.

(3) USER (user-defined)

The user can set the threshold level and hysteresis, the threshold range is -60V~+40V and the hysteresis range is -6V~4V.

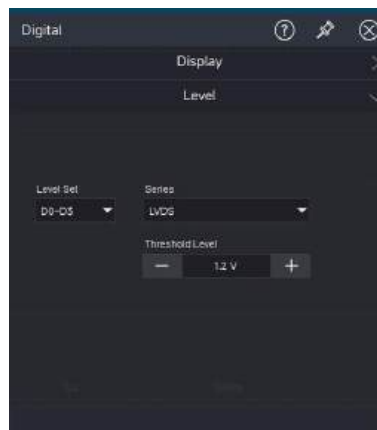

13. Digital Voltmeter and Frequency Counter

- [Digital Voltmeter](#)
- [Frequency counter](#)

MSO8000HD series has built-in 4-digit digital voltmeter and 8-digit high precision frequency meter for accurate measurement. This chapter is to introduce how to use the digital voltmeter and frequency meter.

13.1 Digital Voltmeter

The digital voltmeter measurements in the MSO8000HD series oscilloscopes are asynchronous with the acquisition system of the oscilloscope and are always acquired.

(1) Turn on/off digital voltmeter

Using touch gesture to tap the measurement bar in the lower left > click the voltmeter, or press the **DVM** key in “Function” area on the front panel to turn on/off the digital voltmeter. The measured results of digital voltmeter  displays in the lower right corner of the screen. Click the digital measurement menu to set the display switch of the digital voltmeter (ON/OFF).

Caution: The digital voltmeter is share the same probes with oscilloscope, so the unit digital voltmeter measurement is consistent with the channel’s unit.

(2) Select source

The measuring source can select C1~C4.

(3) Select measuring mode: DC, AC RMS and DC+AC RMS

DC: Display the average of acquired data

AC RMS: Display RMS of acquired data that DC component has removed

DC+AC RMS: Display RMS of acquired data

13.2 Frequency counter

The frequency counter counting measurement can perform on the analog channel of C1~C4.

Turn on/off frequency counter

Using touch gesture to tap the measurement tab in the lower left corner > click the frequency counter to turn on/off the measuring function

The frequency counter is displayed in the lower right corner of the screen. 

The frequency meter supports statistics of maximum value, minimum value, average value, standard deviation, and number of samples.

The frequency meter can switch the measurement results between frequency display and period display.

14. Power Analysis (Option)

- [Input Analysis](#)
- [Output Analysis](#)
- [Switching Analysis](#)
- [Frequency Response Analysis](#)

MSO8000HD series supports power supply analysis, which helps engineers analyze the efficiency and reliability of switching power supplies. MSO8000HD series supports power quality analysis, harmonic analysis, ripple analysis, switching loss, safety operating area and loop analysis.

The power analysis function requires the differential voltage probe (such as UT-PXX series high voltage differential probe), current probe (UT-P4X series), test fixture and the option of oscilloscope's advanced measurement and analysis (MSO8000HD-PWR). The detail of option refers to MSO8000 Series Mixed Signal Oscilloscope-Datasheet.

Using touch gesture to tap the icon of start menu  in the top right corner of the screen to pop out the function menu and click "Power Analysis".

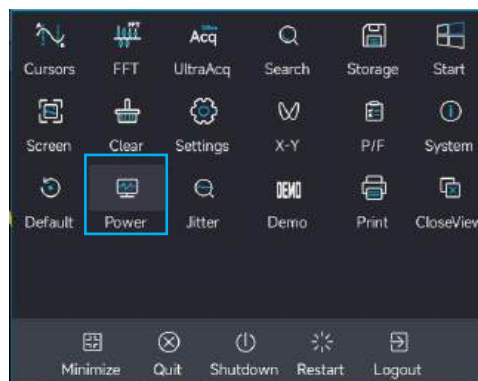

14.1 Input Analysis

14.1.1 Power Quality Analysis

By measuring the input voltage and current as well as the generated power, the test results reflect the quality of the input AC line.

The analysis parameter includes voltage RMS, voltage crest factor, frequency, current RMS, current crest factor, effective power, apparent power, reactive power, power factor and phase angle.

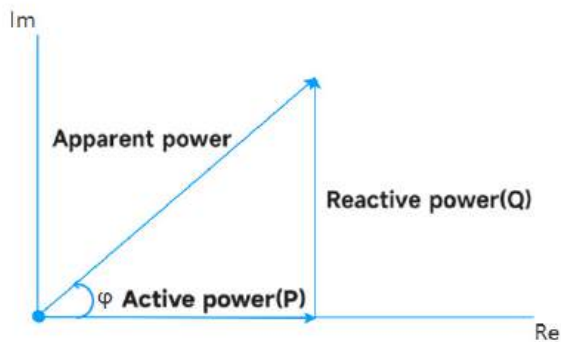

Voltage: measuring the voltage of power input terminal

Voltage RMS: The voltage RMS of input AC power

Voltage crest factor: The ratio of the peak of input AC power voltage and voltage RMS, the crest factor will affect the accuracy of AC measurement

Voltage frequency: The voltage frequency of input AC power

Current: measuring the current of power input terminal

Current RMS: The current RMS of input AC power

Current crest factor: The ratio of the peak of input AC power current and current RMS, the crest factor will affect the accuracy of AC measurement

Power: measuring the power of power input terminal

Effective power: The actual amount of power consumed by a power supply per unit of time, the electrical power that converts electrical energy into other forms of energy, the unit is W.

Apparent power: The product of the input voltage RMS and the input current RMS, it represents the power capacity output to the switching power supply, the unit is V/A;

Reactive power: In AC circuits with reactance components (capacitors and inductors), the electrical power required to establish an alternating magnetic field and induced flux. This part of the energy is converted in the power supply and the inductive element, but no mechanical or thermal energy is generated. The unit is VAR;

Power factor: The ratio of effective power and apparent power, it represents the utilization efficiency of switching power. The lower the power, the higher the reactive power. In addition to the reactive power generated by the reactance components, the high-frequency harmonic components of the nonlinear devices also bring some of the reactive power.

Phase angle φ : The working state of switching power, the phase difference the voltage and current in AC power supply line.

(1) Signal setting of power analysis

Using touch gesture to tap the icon of start menu  in the top right corner to pop out the function menu to click “Power Analysis”. Select the “Power Quality” in analysis type, set the input voltage source and input current channel and click “Add”.



(2) Schematic diagram of signal connecting

Connect the differential probe and current probe to circuit-under-test as the following figure.

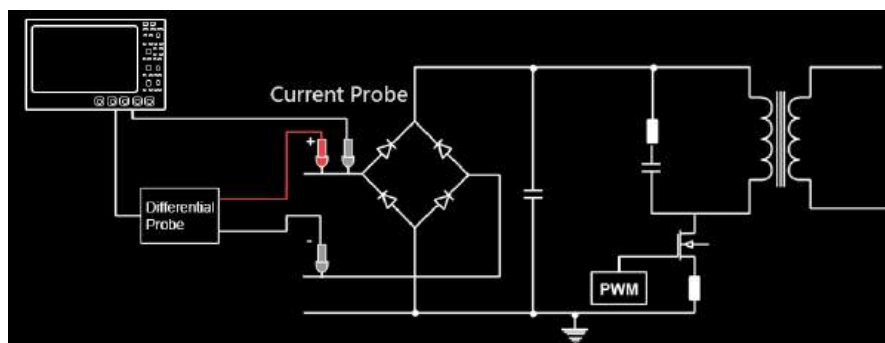

(3) Frequency reference

The input voltage source and the frequency of input current can be the frequency reference for calculating the phase angle φ .

(4) Power figure

The oscilloscope displays the voltage waveform and current waveform, in addition, display the calculated power waveform.



(5) Measured result table

The result of input test includes the current value, the average, maximum and minimum.

Power Quality	Value	Average	Maximum	Minimum
RMS of Voltage	168.99 V	168.81 V	169.28 V	168.06 V
Voltage Crest Factor	1.4595	1.4590	1.4677	1.4198
Frequency	49.996 Hz	49.983 Hz	50.092 Hz	49.910 Hz
RMS of Current	78.545 mA	77.990 mA	79.135 mA	76.366 mA
Current Crest Factor	4.0316	3.9344	4.2613	3.7992
Effective Power	132.74 W	131.65 W	133.79 W	129.08 W
Apparent Power	13.274 VA	13.165 VA	13.379 VA	12.908 VA
Invalid Power	0 Var	0 Var	0 Var	0 Var
Power Factor	1.0000	1.0000	1.0000	1.0000
Phase Angle	0 °			

14.1.2 Harmonic Analysis

Harmonic analysis measures the harmonics of the current/voltage at the input of the power supply. The harmonic values are obtained by testing the current and voltage on the input power line (FFT of the signal is performed to obtain the harmonic components).

(1) Signal setting of harmonic analysis

Using touch gesture to tap the icon of start menu  in the top right corner to pop out the function menu to click “Power Analysis”. Select the “Harmonic Analysis” in analysis type, set the input voltage source and input current channel and click “Add”.



(2) Schematic diagram of signal connecting

Connect the voltage probe and current probe to circuit-under-test as the following figure.

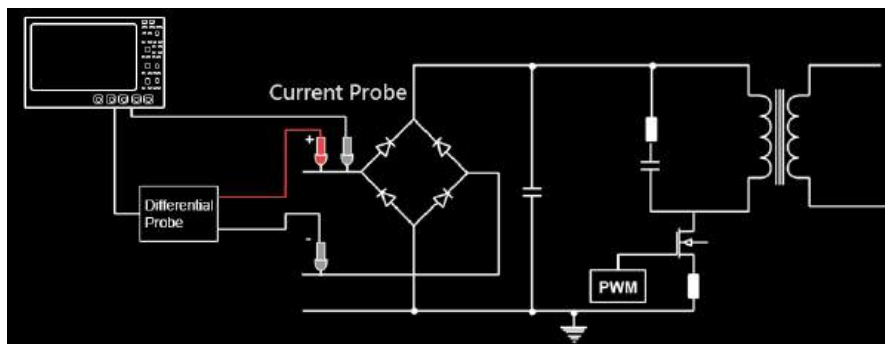

(3) Harmonic source

It can set voltage source/current source

(4) Number of harmonic

Select the number of harmonics to be displayed. After selecting the number, the measured result table and histogram will be updated with the measurement results.

(5) Frequency reference

Harmonic sources, voltage sources, current sources, fixed.

(6) Result table

Harmonic analysis parameters include frequency, measurement, root mean square, and phase.

POWER1-Harmonic Analysis				
THD-R	854.25 m%			
THD-F	854.28 m%			
Root Mean Square	168.81 V			
	Frequency (hz)	Measurement	Root Mean Squa	Phase (°)
1	53.4 Hz	100 %	210 V	-174 °
2	107 Hz	263 m%	550 mV	-180 °
3	160 Hz	559 m%	1.17 V	89.5 °
4	214 Hz	25.4 m%	53.2 mV	-149 °
5	267 Hz	43.6 m%	91.4 mV	-53.5 °
6	320 Hz	2.76 m%	5.78 mV	-68.2 °
7	374 Hz	6.98 m%	14.6 mV	135 °
8	427 Hz	11.7 m%	24.5 mV	93.9 °
9	481 Hz	13.4 m%	28.1 mV	-73.3 °
10	534 Hz	23 m%	48.2 mV	42.6 °
11	587 Hz	20.5 m%	42.9 mV	-133 °
12	641 Hz	190 m%	397 mV	-161 °
13	694 Hz	86.6 m%	181 mV	139 °
14	748 Hz	289 m%	606 mV	119 °
15	801 Hz	43.9 m%	92 mV	-168 °
16	854 Hz	398 m%	833 mV	49.6 °
17	908 Hz	13.1 m%	27.5 mV	46.6 °
18	961 Hz	76.1 m%	160 mV	29.8 °
19	1.01 kHz	6.18 m%	12.9 mV	-128 °
20	1.07 kHz	15.9 m%	33.2 mV	116 °

(7) Harmonic Histogram:

FFT the signal to obtain each harmonic component.

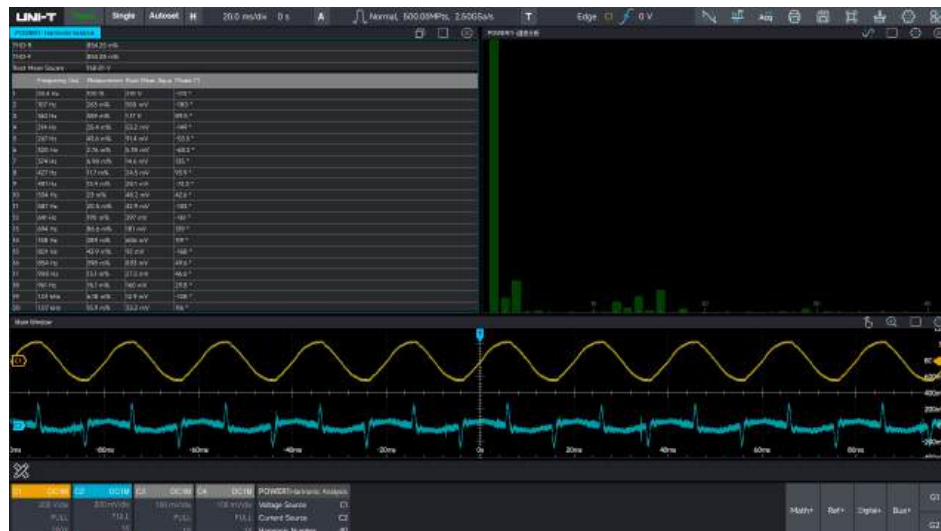

14.1.3 Inrush Current

Inrush current refers to the peak current or overload current that is much higher than the steady-state current, occurring either at the moment when a power device is switched on or under abnormal circuit conditions.

(1) Power analysis signal setting:

Use the touch gesture to click the Start Menu icon  in the upper - right corner of the screen. In the pop - up function menu, click "Power Analysis". Select "Inrush Current" in the analysis type, set the input voltage source and input current source channels, and then click "Add".

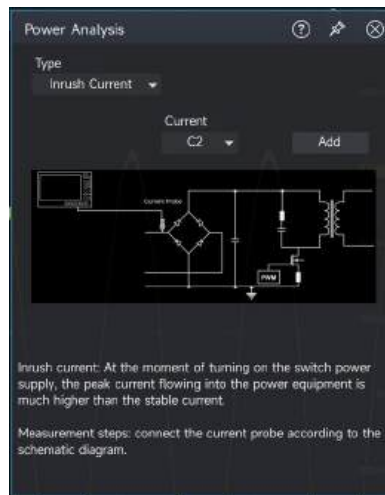

(2) Peak current setting:

Set an appropriate peak current value according to the actual test requirements.

(3) Signal connection diagram:

Please connect the voltage probe and current probe to the circuit under test as shown in the diagram.

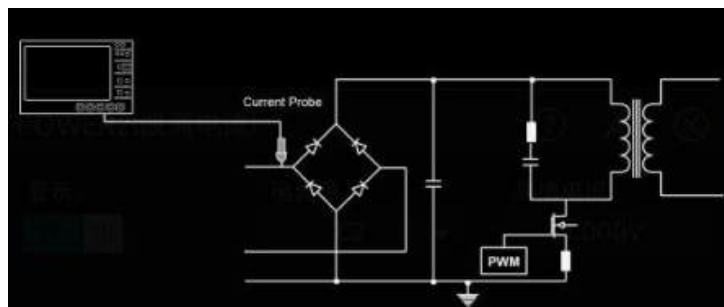

(4) Run analysis:

Click "Run" to enter the "stop" state. After turning off the power as prompted, click "Next". The oscilloscope will automatically set the trigger level value according to the set peak current.

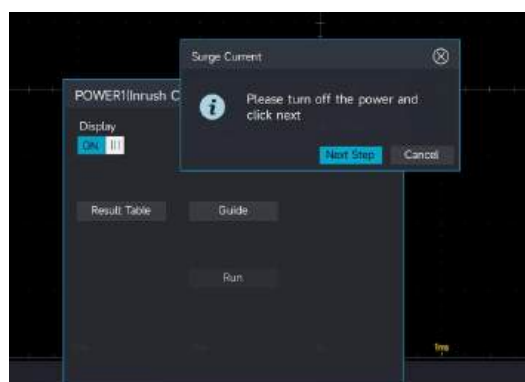

After turning off the power, the oscilloscope enters the ready state for single - trigger. Turn

on the power according to the prompt, and then click "Next".

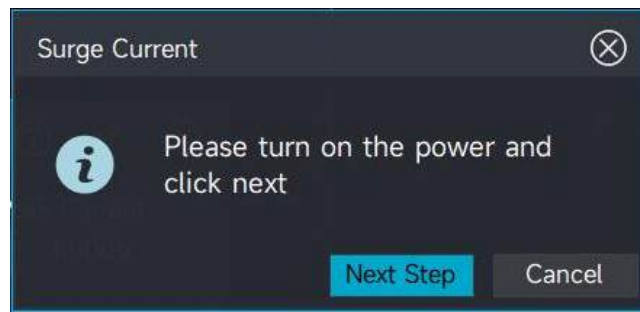

A signal has been captured and the oscilloscope enters the stop mode



(5) Result table:

A list of inrush current analysis parameters, including the maximum, minimum, and peak - to - peak values of the current measurement, as well as the average, maximum, and minimum values accumulated over multiple runs, is displayed.

	Value	Average	Maximum	Minimum
InrushCurrentMax	5.8000 V	5.8000 V	5.8000 V	5.8000 V
InrushCurrentMin	-466.66 mV	-466.66 mV	-466.66 mV	-466.66 mV
Inrush Current	6.2666 V	6.2666 V	6.2666 V	6.2666 V

14.2 Output Analysis

14.2.1 Ripple Analysis

Power supply ripple is an important parameter for evaluating DC power supply. By measuring the

peak-to-peak value of the DC signal output from a power supply, the voltage regulation capability and filtering quality of the DC power supply can be measured. Ripple analysis parameters include current value, average, maximum and minimum value and so on.

(1) Signal setting of ripple analysis

Using touch gesture to tap the icon of start menu  in the top right corner to pop out the function menu to click "Power Analysis". Select the "Ripple Analysis" in analysis type, set the input voltage source and input current channel and click "Add".



(2) Schematic diagram of signal connecting

Connect the voltage probe and current probe to circuit-under-test as the following figure.

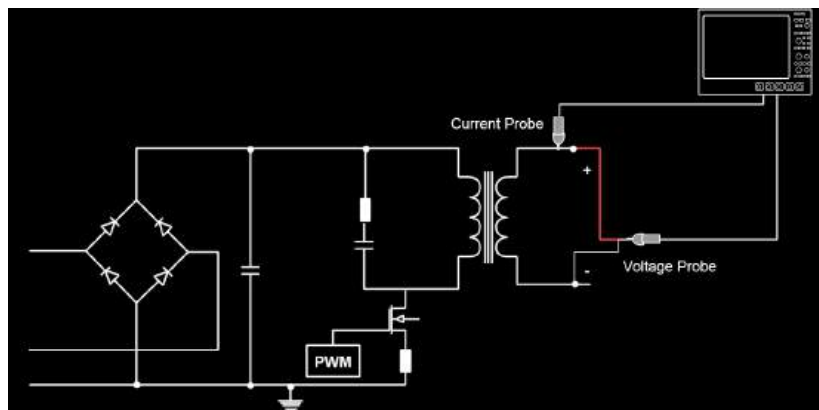

(3) Ripple source

It can set voltage source/current source.

(4) Result table

The result of ripple analysis includes the current value, the average, maximum and minimum.

UNI-T	Auto	Single	Autoset	H	500 μ s/div	6.2695 μ s
Ripple Analysis						
	Value	Average	Maximum	Minimum		
Ripple	266.66 mV	281.32 mV	333.33 mV	266.66 mV		

14.2.2 Power Efficiency

Power efficiency, also known as the power conversion efficiency, generally refers to the situation under full load. When electrical energy is converted through power devices, electrical energy and internal - consumption heat energy are generated (due to different material properties, different internal resistances are produced, and it can also be regarded as a power - consuming device). The ratio of the final electrical energy (represented by active power) to the input electrical energy (represented by active power) is the conversion efficiency.

(1) Power analysis signal setting:

Use touch gestures to click the Start Menu icon  in the upper - right corner of the screen. In the pop - up function menu, click "Power Analysis". Select "Power Efficiency" in the analysis type, set the input voltage source and input current source channels, and then click "Add".

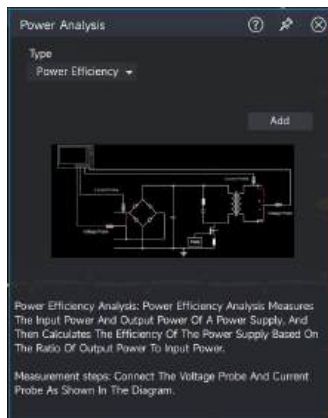

(2) Schematic diagram of signal connecting

Connect the voltage probe and current probe to circuit-under-test as the following figure.

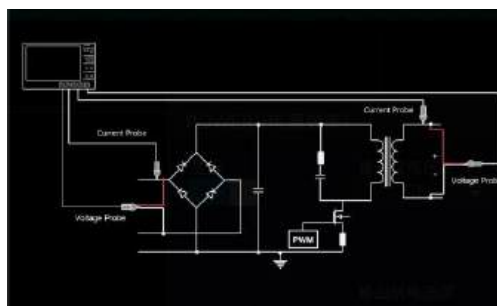

(3) Power graph

In addition to displaying the voltage and current waveforms, the oscilloscope also shows the calculated input and output power waveforms.



(3) Result table

A list of power efficiency analysis parameters is displayed, including input active power, output active power, efficiency, as well as the accumulated average, maximum, and minimum values.

14.2.3 Turn On/Off Time

Turn - on time: The response time when converting the input voltage to the ideal output voltage. The start time is when the input voltage reaches 10% of the peak voltage, and the end time is when the output voltage reaches 90% of the peak voltage. The calculation formula is : $t_{on} = t_{out(90\%)} - t_{in(10\%)}$.

Turn - off time: After removing the input voltage, the response time for the output voltage to approach zero. The start time is when the input voltage drops to 10% of the peak voltage, and the end time is when the output voltage drops to 10% of the peak voltage. The calculation formula is : $t_{off} = t_{out(10\%)} - t_{in(10\%)}$.

(1) Power analysis signal setting:

Use touch gestures to click the Start Menu icon  in the upper - right corner of the screen. In the pop - up function menu, click "Power Analysis". Select "Turn - on and Turn - off Time" in the analysis type, set the input voltage source and input current source channels, and then click "Add".



(2) Peak voltage setting

Set appropriate input and output peak voltages. During operation, the vertical scale of the analog channel and the trigger level value will be adjusted according to the set input/output peak voltages

(3) Conversion type setting

If the input is an alternating current (AC) signal and the output is a direct current (DC) signal, select AC - DC conversion. If the input is a direct current (DC) signal and the output is also a direct current (DC) signal, select DC - DC conversion.

(4) Acquisition time setting

The acquisition time can be set according to different test requirements. The adjustable range is from 200 ms to 1 ks.

(5) Schematic diagram of signal connecting

Connect the voltage probe and current probe to circuit-under-test as the following figure.

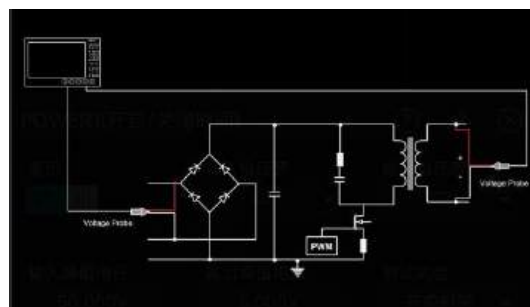

(6) Turn on time run analysis

Click "Run" to enter the stop state. After turning off the power as prompted, click "Next". The oscilloscope will enter the single mode and wait for triggering. The oscilloscope automatically sets the vertical scale of the analog channel and the trigger level value according to the set input/output peak voltages.

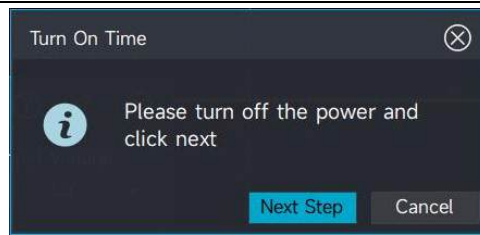

After turning off the power, the oscilloscope enters the single mode and waits for triggering. Turn on the power as prompted, and then click "Next".

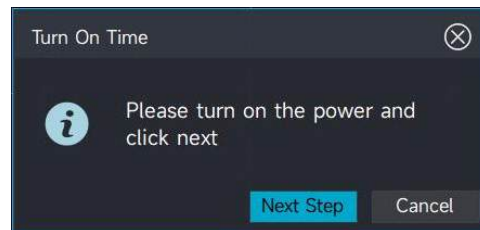

A signal is captured and the oscilloscope enters the stop mode.

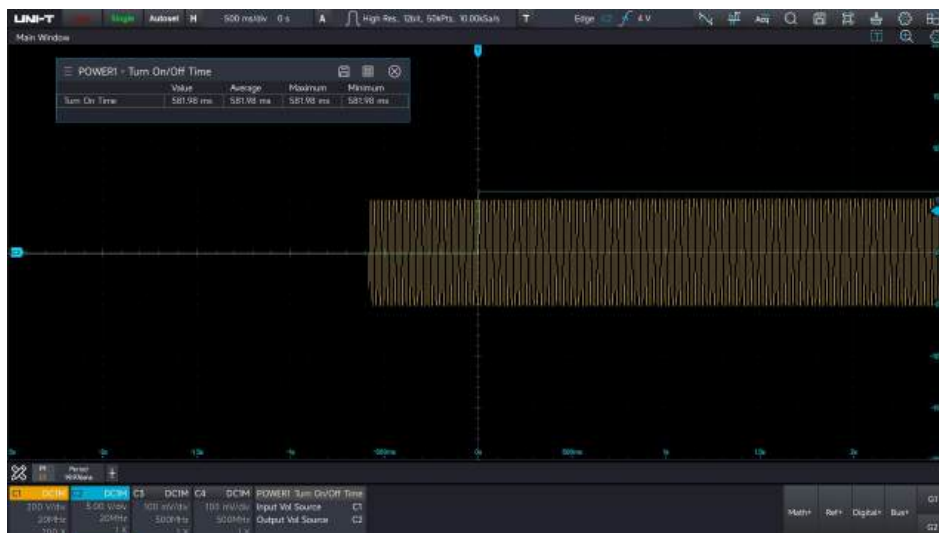

(7) Turn off time run analysis

Click "Run" to enter the stop state. After turning on the power as prompted, click "Next". The oscilloscope will enter the single mode and wait for triggering. The oscilloscope automatically sets the vertical scale of the analog channel and the trigger level according to the set input/output peak voltages.

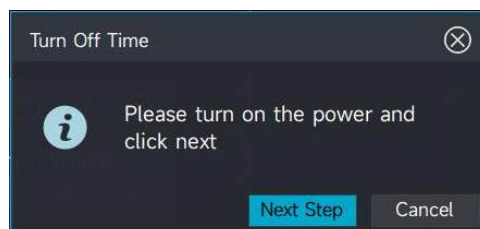

After turning on the power, the oscilloscope enters the single mode and waits for triggering. Turning off the power as prompted, click "Next".

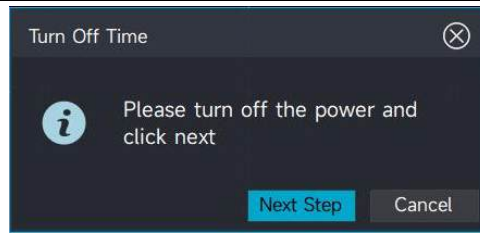

A signal is captured and it enters the stop mode.



(8) Result table

A list of turn - on and turn - off time analysis parameters shows the value of the current measurement, as well as the average, maximum, and minimum values accumulated over multiple turn - on or turn - off operations.

Value	Average	Maximum	Minimum
Turn Off Time	366.85 ms	366.85 ms	366.85 ms

14.2.4 Modulation Analysis

Modulation analysis is used for the measurement of the power supply control loop, mainly for the testing and analysis of the period, frequency, duty cycle, pulse width, rise time, and fall time of the power supply modulation signal.

(1) Signal setting of power analysis

Using touch gesture to tap the icon of start menu  in the top right corner to pop out the function menu to click "Power Analysis". Select Modulation Analysis in the analysis type, set the input voltage source and input current source channels, and then click Add.

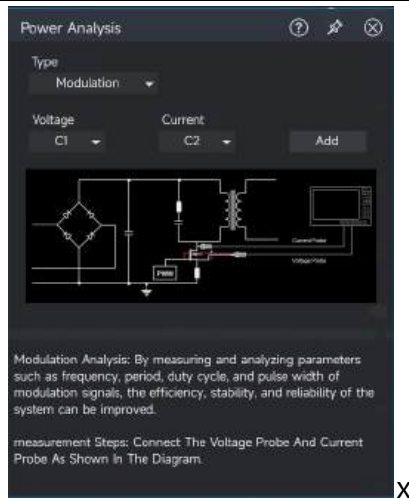

(2) Schematic diagram of signal connecting

Connect the voltage probe and current probe to circuit-under-test as the following figure.

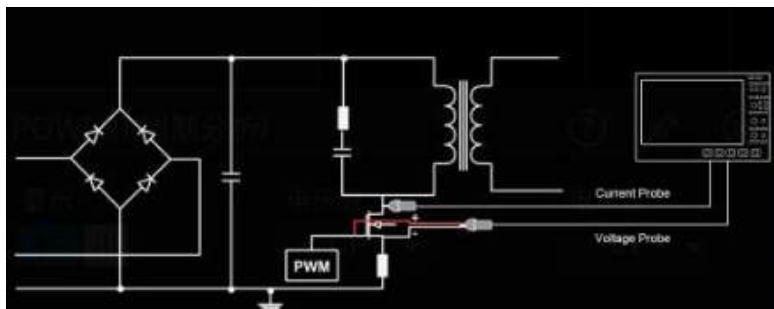

(3) Result table

A list of modulation analysis parameters shows the display of period, frequency, positive duty cycle, positive duty cycle, positive pulse width, negative pulse width, rise time, and fall time.

POWER1 - Modulation				
	Value	Average	Maximum	Minimum
Period	21.495 μ s	21.520 μ s	21.952 μ s	21.417 μ s
Frequency	47.357 kHz	47.303 kHz	47.583 kHz	46.357 kHz
PDuty	10.778%	10.661%	10.965%	10.443%
NDuty	89.222%	89.339%	89.557%	89.035%
PWidth	2.2885 μ s	2.2673 μ s	2.3307 μ s	2.2236 μ s
NWidth	19.205 μ s	19.253 μ s	19.679 μ s	19.129 μ s
Rise Time	1.1063 μ s	1.2098 μ s	2.1639 μ s	792.13 ns
Fall Time	373.02 ns	366.57 ns	385.03 ns	232.99 ns

(4) Histograms and Trend Charts:

In addition to displaying the measured values, modulation analysis can also add histograms and trend charts for the measured parameters.



14.3 Switching Analysis

14.3.1 Switching Loss

Internal loss of the switching power can divide into switching loss, conducting loss, additional loss and resistance loss. These losses usually occur simultaneously in lossy components. And power switches are one of the two most significant sources of loss within a typical switching power supply. The switching loss analysis measures the power and energy loss of a switching device during the switching and conduction phases of a transistor. The parameter of switching loss analysis includes open power loss, conducting power loss, close power loss, non-conducting power loss, total power loss, open energy loss, conducting energy loss, close energy loss, non-conducting energy loss, total energy loss and number of switching cycle.

(1) Probe degaussing

Before using the switching loss analysis, the current probe should be degaussing and zero clearing.

(2) Time-delay calibration

The smaller time-delay will cause larger switching loss measurement errors. The time-delay calibration can correct the time delay of oscilloscope or probe. The time lag calibration should be performed one time and rerun when any part of the hardware setup is changed (e.g., changing probes, changing oscilloscope channels,) or when the temperature environment changes.

(3) Signal setting of power analysis

Using touch gesture to tap the icon of start menu  in the top right corner to pop out the function menu to click “Power Analysis”. Select the “Switching Loss” in analysis type, set the input voltage source and input current channel and click “Add”.



(4) Schematic diagram of signal connecting

Connect the voltage probe and current probe to circuit-under-test as the following figure.

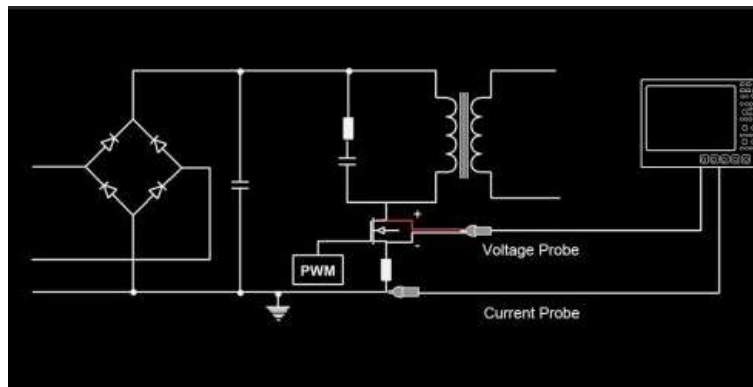

(5) Power figure

The oscilloscope displays the voltage waveform and current waveform, in addition, display the calculated power waveform.



(6) Result table

The result of switching loss includes the current value, the average, maximum and minimum.

Switching Loss	Value	Average	Maximum	Minimum
Turn-on Power Loss	68.506 mW	40.456 mW	835.88 mW	0 W
Conduction Power Loss	471.95 mW	389.99 mW	8.2927 W	537.50 μW
Shutdown Power Loss	57.351 mW	31.934 mW	578.37 mW	1.7024 mW
Total Power Loss	597.81 mW	462.38 mW	8.4608 W	11.190 mW
Turn-on Energy Loss	1.3701 μJ	2.5599 μJ	41.737 μJ	0 J
Conduction Energy Loss	9.4390 μJ	4.4518 μJ	92.225 μJ	15.136 nJ
Shutdown Energy Loss	11.470 μJ	17.310 μJ	300.05 μJ	11.962 nJ
Total Energy Loss	22.279 μJ	24.322 μJ	300.69 μJ	29.832 nJ

14.3.2 Safety Operation Area

The safety operation area is X-Y mode of switching device voltage and current. SOA template test provides Pass/Fail test results, and power device violations at different loads can directly observe in the safety operation area.

(1) Signal setting of power analysis

Using touch gesture to tap the icon of start menu  in the top right corner to pop out the function menu to click “Power Analysis”. Select the “SOA” in analysis type, set the input voltage source and input current channel and click “Add”.



(2) Schematic diagram of signal connecting

Connect the voltage probe and current probe to circuit-under-test as the following figure.

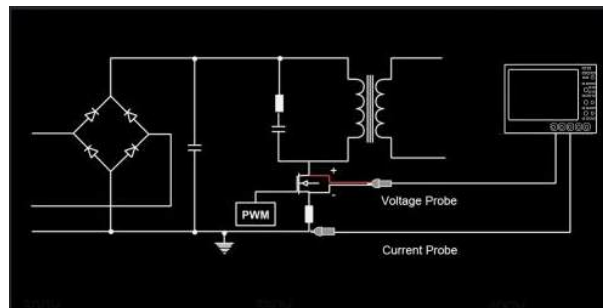

(3) Stop and reset

In SOA test, set to automatically stop and resume the test when the violation occurs.

(4) SOA axis type

It can set linear/logarithm

(5) SOA template

Set the maximum voltage, current and power

(6) SOA template display

Set X-axis maximum voltage, X-axis minimum voltage, Y-axis maximum voltage and Y-axis minimum voltage

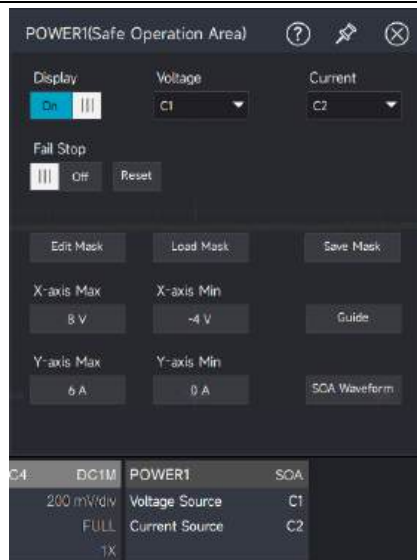

(7) SOA waveform figure

When it is turned on, SOA waveforms will be displayed in the template test area, and you can visualize whether the SOA waveforms press the template or not, as well as the SOA template test results, the number of captured waveforms, and the number of failed waveforms.

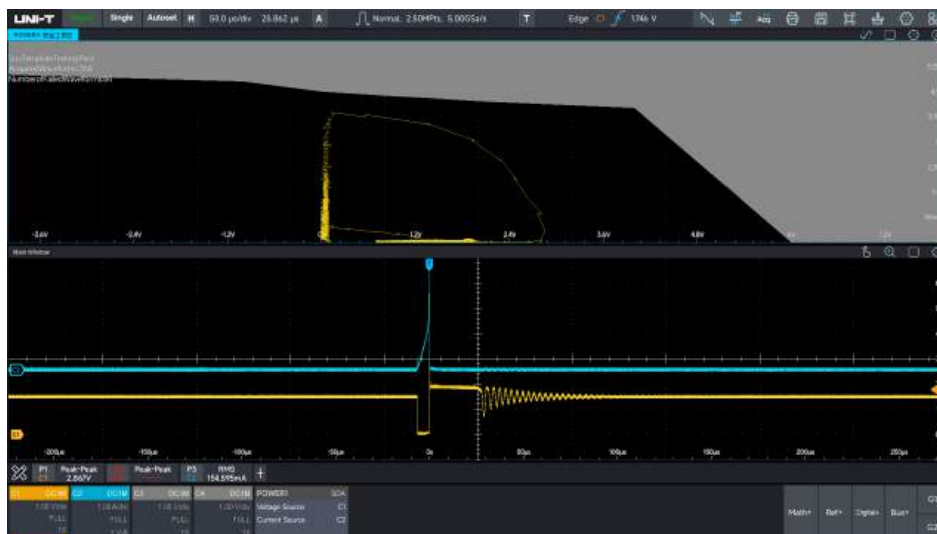

14.3.3 Rds(on)

Rds(on) is the equivalent resistance between the Drain and the Source during the turn - on transient, also known as the drain - source on - resistance.

(1) Signal setting of power analysis

Using touch gesture to tap the icon of start menu  in the top right corner to pop out the function menu to click “Power Analysis”.Select Rds(on) in the analysis type, set the input

voltage source and input current source channels, and then click Add.

(2) Schematic diagram of signal connecting

Connect the voltage probe 1, voltage probe 2 and AWG output signal to circuit-under-test as the following figure.

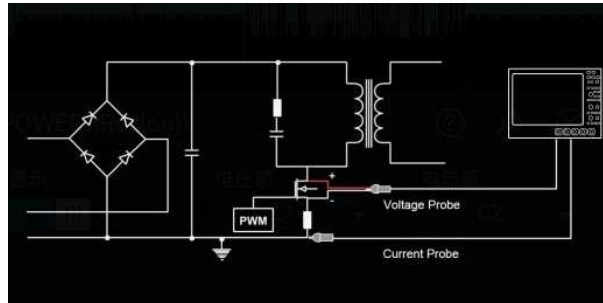

(3) Result table

A list of Rds(on) analysis parameters includes the value of the current measurement, as well as the displayed average, maximum, and minimum values of the accumulations.

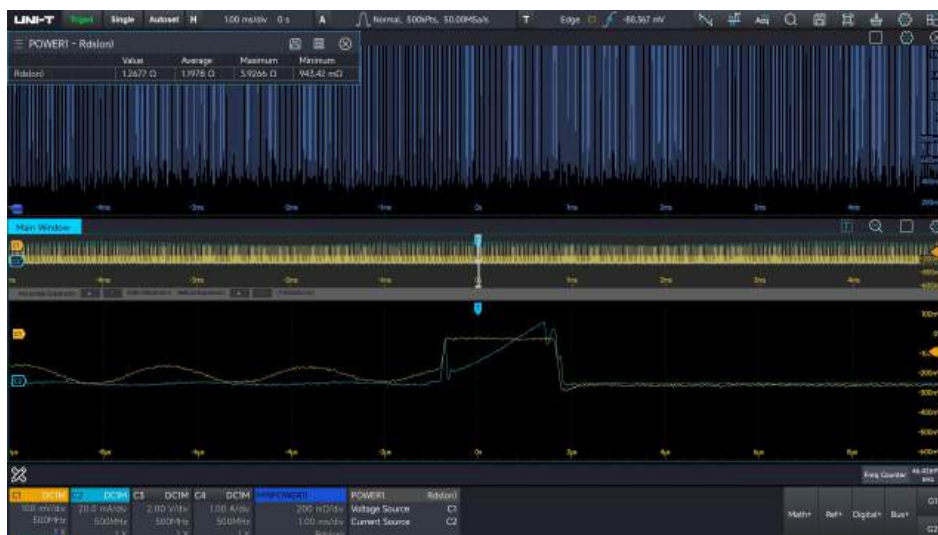

14.3.4 Slew Rate

The slew rate refers to the rate of rise and fall of voltage or current of a power device during the switching process.

(1) Signal setting of power analysis

Using touch gesture to tap the icon of start menu  in the top right corner to pop out the function menu to click “Power Analysis”.Select slew rate in the analysis type, set the input voltage source and input current source channels, and then click Add.

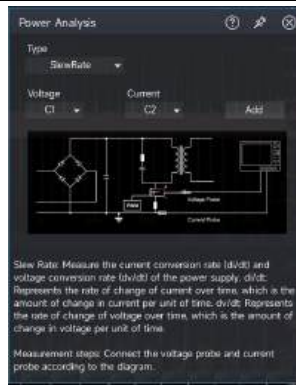

(2) Schematic diagram of signal connecting

Connect the voltage probe 1, voltage probe 2 and AWG output signal to circuit-under-test as the following figure.

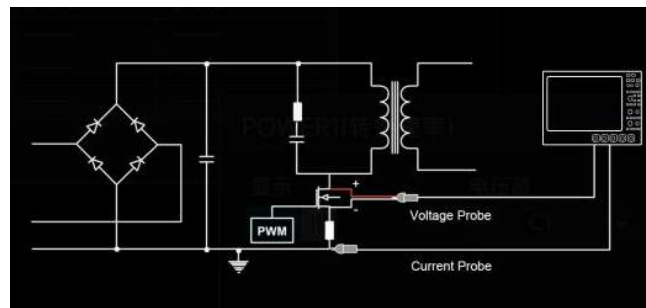

(3) Result table

A list of slew rate analysis parameters shows the results of the rising and falling edges of dv/dt and di/dt respectively, including the current maximum value, minimum value, peak - to - peak value, as well as the cumulative average value, maximum value, and minimum value.



14.4 Frequency Response Analysis

14.4.1 PSRR

PSRR is a metric that characterizes the power supply rejection capability of a circuit. It provides a measure of the circuit's ability to reject ripples of different frequencies introduced at its input. The

basic calculation formula is : $PSRR = 20 \log \frac{Ripple_{in}}{Ripple_{out}}$

(1) Signal setting of power analysis

Using touch gesture to tap the icon of start menu  in the top right corner to pop out the function menu to click "Power Analysis". Select PSRR in the analysis type, set the input voltage source and input current source channels, and then click Add.

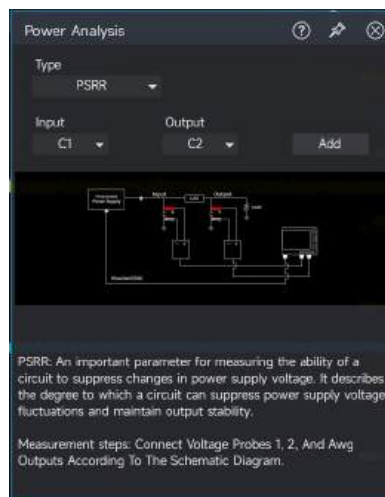

(2) Set impedance:

It is possible to set 50Ω and high impedance. The specific setting depends on the loop impedance value. The core principle is that the injection resistance inserted into the loop should not affect the steady - state value of the loop.

(3) Schematic of signal connection:

Please connect voltage probe 1, voltage probe 2 and the output signal of the AWG to the circuit under test as shown in the diagram.

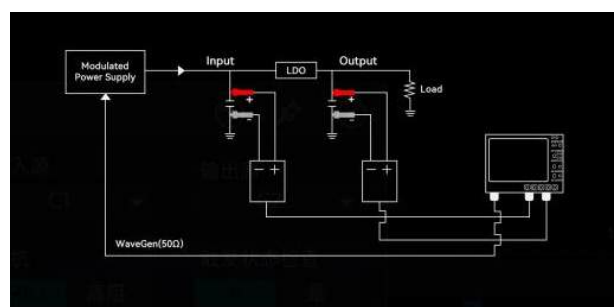

(4) Set start frequency and stop frequency:

The start frequency and cut - off frequency settings should not exceed the output frequency of the function signal generator. The frequency range setting needs to cover the corner frequency of the power supply loop bandwidth. When testing a switching power supply, it should include the switching frequency of the switching power supply and its harmonics.

(5) Set the number of sweep points:

The number of sweep points can be set from 1 to 1000. The more points there are, the relatively slower the scanning speed will be.

(6) Set signal output amplitude:

Constant amplitude and variable amplitude can be set. Reasonably set the amplitude of the injected AC disturbance signal according to different test scenarios and requirements.

(7) Click "Run Analysis".

(8) PSRR curve graph:

Test the input disturbance amplitude and output response amplitude of the device at different frequency points, calculate the PSRR (unit: dB) of each frequency point according to the formula. The X - axis represents the frequency (Hz), and the Y - axis represents the PSRR value to draw the PSRR curve.

(9) Data list:

A list of PSRR analysis parameters shows the display of frequency, amplitude, and PSRR.

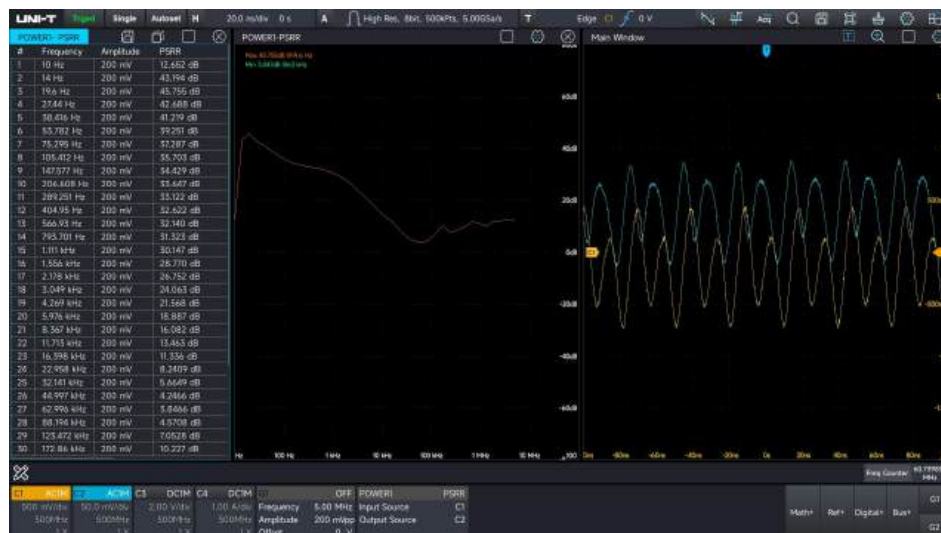

14.4.2 Loop Analysis

The loop analysis is to input a positive wave signal with changing frequency to the switching power supply circuit as an interference signal, and judge the dynamic adjustment ability of the circuit system to each frequency interference signal according to its output. This test requires the option MSO8000HD-AWG (function/arbitrary waveform generator) to output the interference signal with different frequency. And it also requires a signal injector or an isolation transformer to input the signal to the circuit system, and two voltage probe is used to detect the input and output signal in loop circuit.

During the scanning, the oscilloscope will automatically configure the output signal of the function/arbitrary generator and connect to DUT, and then compare the input signal of DUT to the output signal, measuring “Gain” and “Phase” on each frequency and drawing in the bode diagram.

(1) Signal setting of power analysis

Using touch gesture to tap the icon of start menu  in the top right corner to pop out the function menu to click “Power Analysis”. Select the “Loop Analysis” in analysis type, set the input source and output source channel and click “Add”.

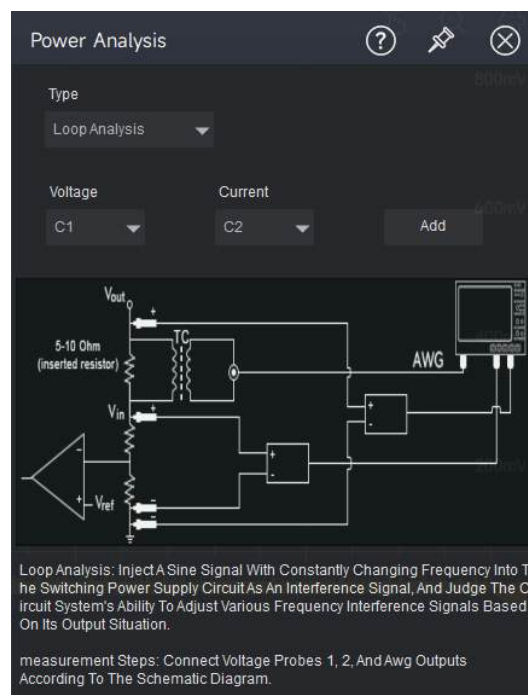

(2) Schematic diagram of signal connecting

Connect the voltage probe 1, voltage probe 2 and AWG output signal to circuit-under-test as the following figure.

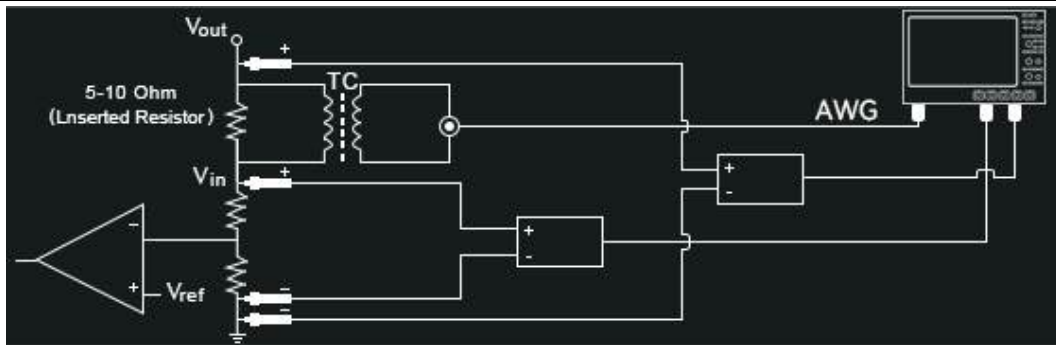

(3) Scanning mode

It can set continuous scanning and single scanning

(4) Impedance

It can set $50\ \Omega$ and high resistance. The setting depends on the resistance value of the loop.

The core principle: the injection resistor is inserted into the loop and must not affect the steady state value of the loop.

(5) Start/Cutoff frequency

The starting frequency and cutoff frequency should not exceed the output frequency of the function signal generator. The cutoff frequency of the loop system is recommended to be set as $1/20$ to $1/6$ of the switching frequency. In this range, the crossing frequency point of the loop can be generally found.

The crossing frequency should not be too low, otherwise the loop will not be able to respond to high-frequency load fluctuations, thus causing noise in the output voltage.

(6) Scanning count

The scanning count can set 1~1000. The more the count, the slow the scanning speed.

(7) Output amplitude of signal

The output amplitude of signal can set to constant amplitude or adjustable amplitude.

The amplitude of the injected signal can be set to 5% of the output voltage, the oscilloscope may not be able to recognize it if the amplitude is too small, it may lead to nonlinearities in the system resulting in measurement distortion if the amplitude is too large.

(6) Click to running analysis

(9) Bode diagram

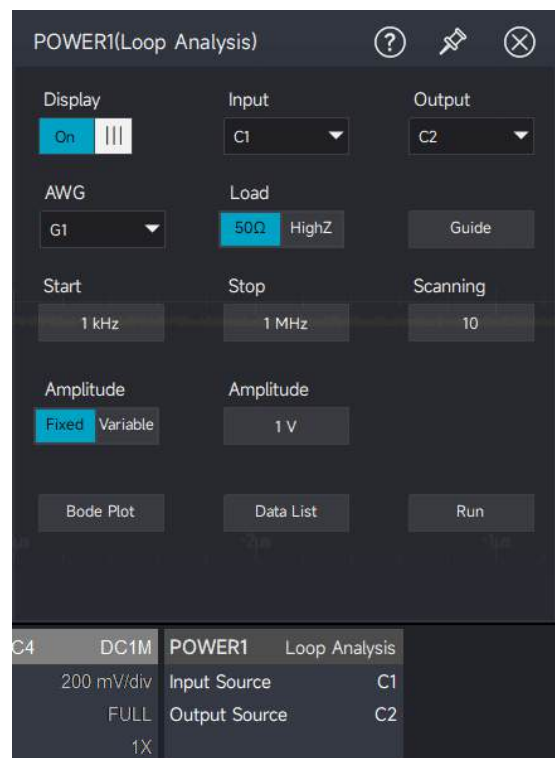

Bode diagram provides the frequency response curve of DUT.

(10) Data list

The data includes frequency, amplitude, gain and phase display.

15. Jitter Analysis and Eye diagram (Option)

- [Eye-diagram](#)
- [Measurement Parameter of Eye diagram](#)
- [Jitter Analysis](#)
- [Clock Recovery](#)
- [Jitter Resolving](#)
- [Measurement Parameter of Jitter](#)
- [Effect of Test System on Jitter Test](#)

Eye diagram and jitter analysis is a set of tools for signal integrity analysis of high-speed interconnect systems, which has a lot of information.

Eye diagram is a statistical distribution diagram formed by stacking the data bits at different positions of high-speed digital signals according to clock intervals. An eye diagram reflects overall feature of all digital signals in transmission link.

Jitter analysis is the noise and phase changes that occur on the edges of a signal, and they can cause timing errors in the signal. With the improving of signal rate, the interference factors in the data transmission link will increase, the signal loss and transmission quality should be more concerned, so the designer must master the signal quality in the signal transmission process from TX to RX. Jitter analysis is a tool that helps engineers accomplish this type of testing MSO8000HD series provides a suite of tools for visual jitter analysis and eye diagram testing, providing a complete analysis of signal quality in the time, frequency and statistical domains. Through the eye diagram test, the user can know the complete characteristics of the digital signal. TIE histogram tells you the distribution of jitter. TIE tendency chart displays the trend of jitter. You can confirm the jitter at a certain point by TIE spectrogram, so as to make a targeted design. In addition, it has bathtub curve and Q factor curve to help you make further judgments about jittering.

This chapter will introduce jitter and eye diagram test in detail.

15.1 Eye-diagram

Eye diagram is a method of analyzing high-speed digital signals, the oscilloscope separates all the code elements of a digital signal and superimpose them on the screen display at clock intervals, thus creating an eye-like effect.

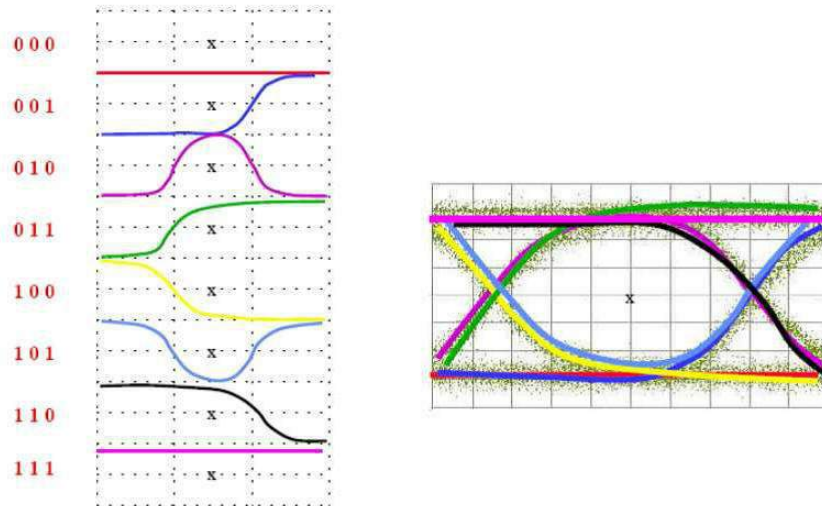

Rapid generating an eye diagram

Using touch gesture to tap the start menu  in the top right corner to pop out the function menu and click “Jitter analysis”.

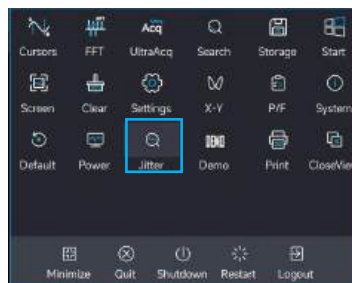

- (1) Click to enter the measurement menu of jitter analysis, to enable the jitter analysis and connect the digital signal to the oscilloscope's channel.
- (2) Select the analysis source: C1~C4
- (3) Select the analysis signal: data signal/clock signal
- (4) Set the comparison of threshold, hysteresis and duration of data mode.

Comparison of threshold: between 45%~55%, the default is 50%.

Hysteresis: between 0%~30%, the default is 20%.

Duration of data mode: 0~4.295Gbit, the default is 127bits.

- (5) Figure: Eye diagram



- (6) Search bit rate or input the bit rate by manual (finding the bit rate may not be accurate due to the complexity of the signal, so it is recommended to enter it manually.)
- (7) Clock recovery
- Constant clock: The least squares method is used to fit the collected data linearly, and the recovered clock frequency is constant.
- PLL: Based on the software phase-locked loop to calculate the position of each reference clock edge, the phase-locked loop has a certain tracking ability to clock changes, it can remove the low-frequency components of jitter, and supports type 1 and type 2.
- Type 1 is also called the first order Golden PLL, it requires configure the cut-off frequency and cut-off coefficient of phase-locked loop to set the bandwidth of loop. In generally, if the cut-off coefficient is less than 5Gbps, it sets to 1667 (empirical value); if the cut-off coefficient greater than 5Gbps, it sets to 2500 (empirical value).
- Type 2 is also called the second order Golden PLL, it should set the natural frequency and damping factor.
- (8) Open the eye diagram, the eye diagram is drawn by superimposing long data bits, so the storage depth and sampling rate will affect the quality of the eye diagram, and also affect the time of drawing.

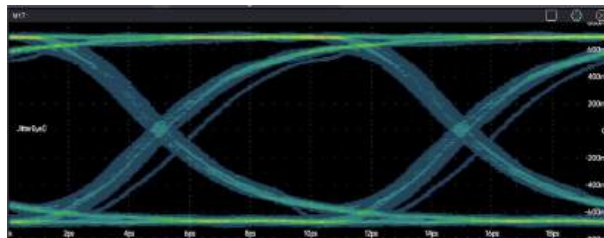

15.2 Measuring Parameter of Eye Diagram

Using touch gesture to tap the parameter of eye diagram to enable it. Pop out the overall list of eye diagram. This section is to introduce the parameter of eye diagram in detail.

Eye Parameters	
Items	Value
0 Level	-22 mV
1 Level	56.667 mV
Eye Amplitude	78.667 mV
Eye Height	73.722 mV
Eye Width	500 μ s
Extinction Ratio	8.074
Q-factor	47.724
Eye-crossing Ratio	27.12 %

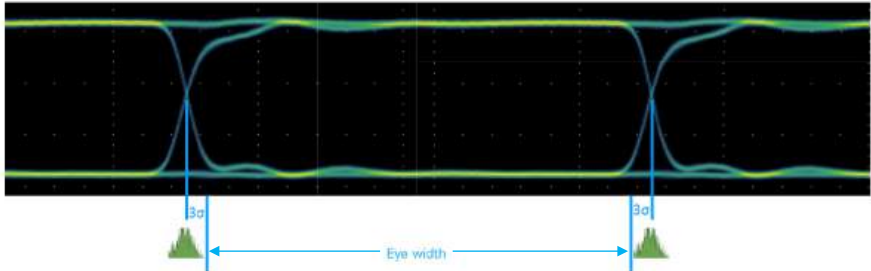
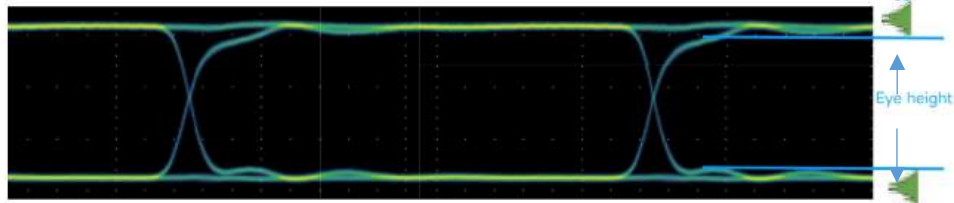
Parameter	Description
Eye width	<p>The width of the eye diagram opened in the horizontal direction. It is estimated based on the probability distribution of eye intersection in the horizontal direction.</p> 
Eye height	<p>The height of the eye diagram opened in the vertical direction. Estimated based on the probability distribution of 1-level and 0-level in the vertical direction over the 40% ~ 60% UI interval</p> <p>It is estimated based on the probability distribution of 1-level and 0-level within the UI interval of 40% ~ 60% in the vertical direction.</p> 
1-level	The level of eye diagram "1". Take the middle 20% of the UI to counted on vertical and calculate the average of high place.
0-level	The level of eye diagram "0". Take the middle 20% of the UI to counted on vertical and calculate the average of low place.

Eye amplitude	Eye amplitude, the difference value between 1-level and 0-level.
Cross ratio of eye	The ratio of the amplitude of the intersection to 0-level to the eye amplitude.
Extinction ratio	It reflects the noise immunity of the transmitted signal, defined as the ratio of the power average "1" to the power average "0".
Q factor	The ratio of eye amplitude to noise amplitude at 1-level and 0-level.

15.3 Jitter Analysis

Jitter analysis function is mainly used to analyze the signal integrity of high-speed serial systems, TIE jitter is a common jitter measurement indicator.

MSO8000HD provides TIE tendency chart /TIE spectrogram, histogram and bathtub curve for jitter visualization to further locate jitter conditions.

The operation of jitter analysis is same as drawing eye diagram, please refer to the section of ["Eye Diagram"](#).



TIE (Time Interval Error) is the timing error of the signal relative to the reference clock. TIE is jitter in high-speed digital systems, TIE in this oscilloscope refers to TIE_{peak-peak}. The edge of the measured signal is compared with the ideal edge established by the clock recovery, and all the signal intervals are measured according to the ideal data rate.

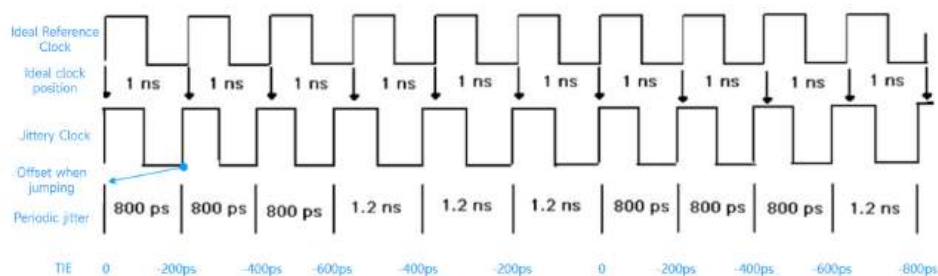

Cycle-Cycle

Measure the cycle of the first signal, and use the cycle of the second signal to minus the cycle of the first signal, and so on.

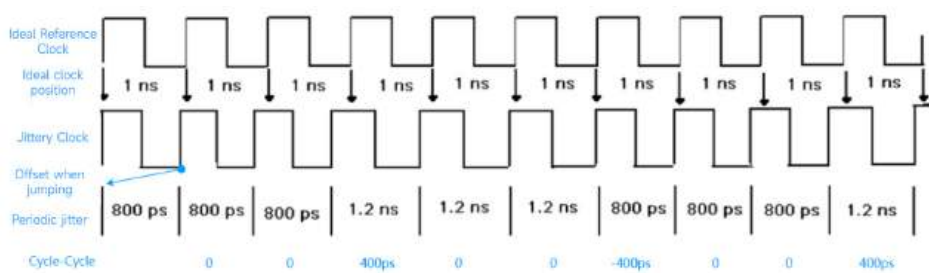

TIE tendency chart: The chart obtained from the time trend statistics of TIE jitter measurements, it belongs to the time domain analysis of jitter. The horizontal indicates the time when measurement occurred, and the vertical indicates the value of the TIE jitter measurement. TIE tendency chart can present the jitter offset for each cycle, thus to understand the temporal trend of the signal jitter.

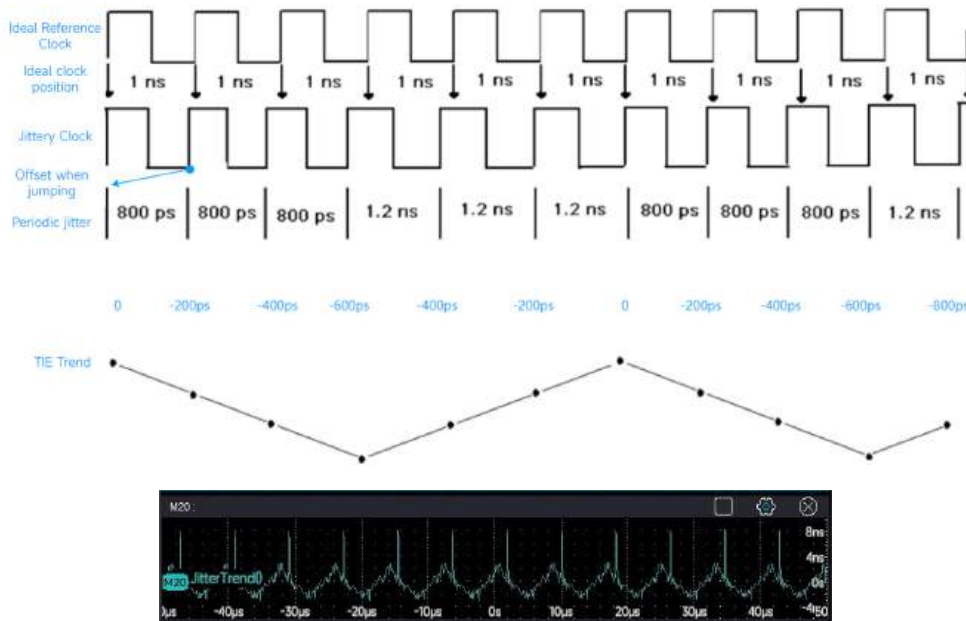

Jitter histogram: By statistically analyzing the offset of jitter, the histogram can present the distribution of different jitter offsets, thus to understand the distribution of jitter in the clock signal. The horizontal represents the jitter offset, and the vertical represents the number of measurements accumulated at any offset.



TIE spectrogram: The spectrum of the jitter is obtained by performing FFT on the jitter, and the distribution of the jitter in the frequency domain is accurately localized. The horizontal represents the signal frequency, and the vertical represents the measured value of signal jitter.

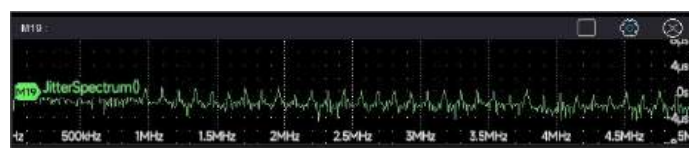

Bathtub curve: This curve shows the variation of BER (bit error ratio) with the judgment moment. This curve shows the BER and the cumulative number of times, so the degree of eye diagram opening under BER can be easily analyzed. It is usually observe the degree of eye diagram opening under BER-12, and jitter must be accompanied by BER to be meaningful.

The horizontal represents the degree of eye diagram opening, the unit is UI. The vertical represents the number of accumulated bit.

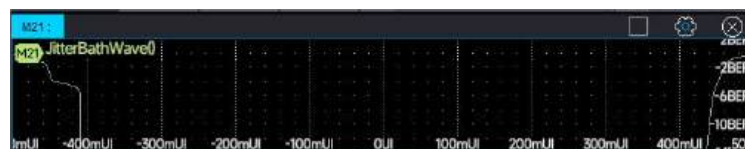

15.4 Clock Recovery

The setting method of clock recovery is same as eye diagram, please refer to the section of [“Eye Diagram”](#).

15.5 Jitter Resolving

Jitter resolving is decomposing the different components (as shown in the following figure) of jitter based on acquired TIE measured data.

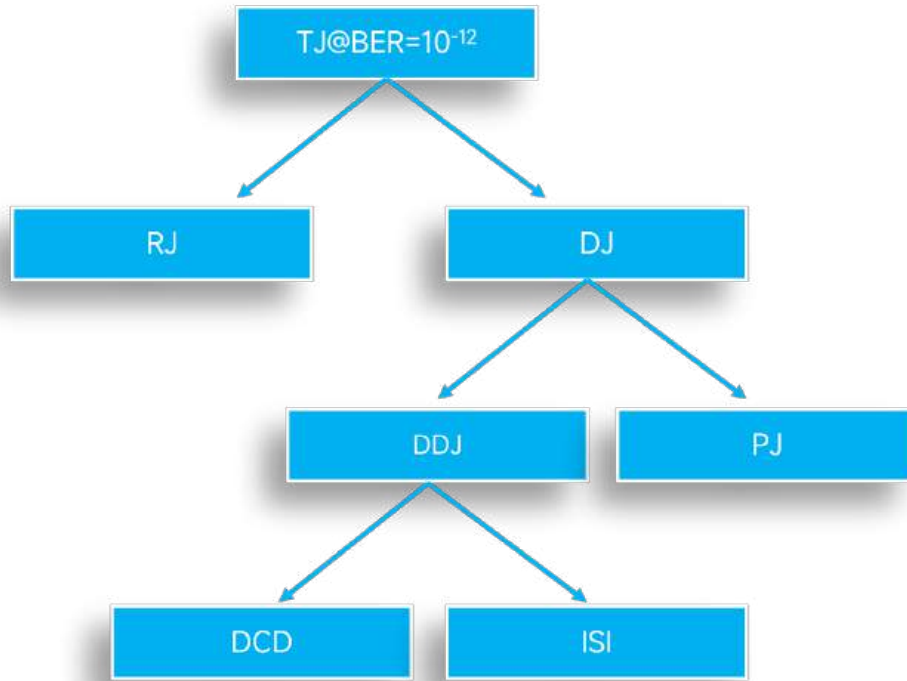

Parameter of Jitter	Description
TJ@BER=e ⁻¹²	The total jitter is estimated based on BER. $TJ = DJ + 2Q_B \cdot \sigma_{RJ}$ Q_B will be different according to different BER. When $BE = 10^{-12}$, $Q_B = 7.05$
RJ (Random jitter)	In generally speaking, the random jitter PDF (probability density function) in line with the Gaussian normal distribution. Theoretically, the larger the number of samples, the wider the distribution range of the test, if the sample is large enough, the distribution range tends to infinity, so it is unbounded. The size is expressed by the standard deviation σ . RJ is mainly come from internal thermal phenomena, vibrations of thermal molecules and atoms, mechanical noise, external cosmic rays, etc., which cannot be eliminated.
DJ (Deterministic jitter)	The distribution of deterministic jitter is limited.
DCD (Duty cycle distortion)	Duty cycle distortion is the dissymmetry of jumping edge (rising edge and falling edge). The clock duty cycle is not 50%, rising and falling edges are not equal, and the reference level is not properly selected, all of which can cause duty cycle distortion.
DDJ	Data dependent jitter is mainly come from ISI (Inter-symbol interference). Due to the non-ideal characteristics of the frequency response of the digital signal transmission channel, when different code types pass through the channel, it will produce inconsistent size of the rising/falling

	<p>edges, thus generating different over-zero positions.</p> <p>Such as, frequently switching high-frequency signal of “1,0,1,0...”, the attenuation is much higher than the continuous high-frequency signal of “1,1,1,0,0,0,0,0,...”, so it takes a long time to reach a higher level without changing the code pattern, and it takes more time to reach the judgment threshold level during the hopping, which leads to signal jitter.</p> <p>In addition, because the impedance mismatch leads to signal reflection, the reflected signal superimposed on the original signal leads to an increase in amplitude resulting in premature judgment, thus causing jitter, so the PDF of the DDJ is expressed as a number of discrete line distribution.</p>
ISI	Inter-symbol interference
PJ (Periodic jitter)	<p>Periodic jitter mainly caused by the board's periodic signal interference, such as power ripple of switching power supply and clock crosstalk.</p> <p>Periodic jitter and phase modulation are equivalent.</p>

The meaning of jitter dissolving

After the jitter dissolving is completed, the TJ at any BER can be estimated from a finite sample of jitter measurements to save test time if the RJ is estimated correctly. By analyzing the cause of the formation of each component, it is possible to backtrack to the reason of the formation when a component is tested, which helps to quickly locate the problem.

15.6 Measuring Parameter of Jitter

The measuring parameter of jitter refers to the section of [“Jitter Resolving”](#).

15.7 Effect of Test System on Jitter Test

(1) Bandwidth of test system

The bandwidth of test system includes an oscilloscope, probe, testing cable and test fixture. In generally speaking, the bandwidth of test system (oscilloscope and probe) should \geq five times of the signal to be measured, so the fifth harmonic of signal can be resolved. The testing cable and test fixture must conform to the standard and code requirements, if it lower to the code requirements will bring additional ISI jitter.

(2) Real-time sampling rate of oscilloscope

Usually, higher sample rates will have higher resolution and edge resolution, and these effects will be reflected in the jitter analysis results, higher sample rates mean higher accuracy.

(3) Instrument's ground noise and intrinsic jitter

The jitter is an error in time, and its test results will be affected by the inherent jitter of the instrument.

(4) Waveform's sample number

The oscilloscope's storage depth is an important indicator in jitter analysis, it directly affect the sample number of jitter and eye diagram test. Sufficiently long waveform data also means that lower frequency jitter can be captured, in addition to providing a longer clock period or data UI for more accurate jitter analysis. This is also one of the important values of oscilloscope's long storage

(5) Clock recovery

Different method of clock recovery will affect the superposition of eye diagrams. The clock frequency is constant after constant clock recovery, so it can only be used to analyze signals with a constant clock. If clock jumping becomes serious, the measurement performance will not be good, so it is necessary to select the PLL (phase-locked loop) clock recovery.

16. Consistency Analysis (Optional)

For the specific operation of the consistency analysis function, please refer to the 《100M BASE-Tx Ethernet Consistency Analysis User Manual V1.0》

17. Sequence Mode

- [Sequence Mode](#)
- [Single Frame](#)
- [Consecutive Frame](#)

The sequence mode is a fast acquisition mode based on UltraAcq® technology, which divides the oscilloscope's storage depth into multiple segments, with only a single triggered waveform stored in each segment. When the number of storage waveform does not reach the set number of frames, the oscilloscope only performs acquisition and storage, and does not perform display and data processing. In the sequence mode, the dead time of oscilloscope's trigger event will be minimized, so the waveform refresh rate is greatly improved. In UltraAcq® mode, the oscilloscope can achieve a minimum trigger interval of 1 μ s, which corresponds to a waveform capture rate of 800,000 wfms/s.

17.1 Setting the sequence mode

(1) Turn on sequence mode

Using touch gesture to tap the label of acquisition, storage depth and sampling rate, select sequence mode in sampling setting menu.

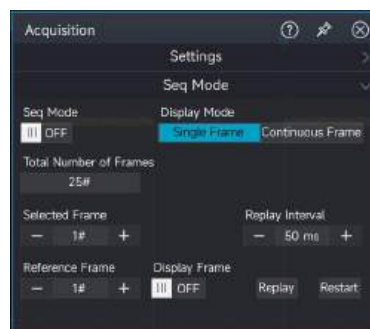

(2) Select display mode: single/consecutive frame

Single frame: select a frame of waveform to display on the screen.

Consecutive frame: the frame number range (maximum 20 frames) can be set and displayed on the screen at the same time.

(3) Set total frame

The total frame is related to the storage depth. The oscilloscope splits the storage depth into segments of equal length, and sets the higher the storage depth, the fewer segments are split.

(4) Enable sequence mode

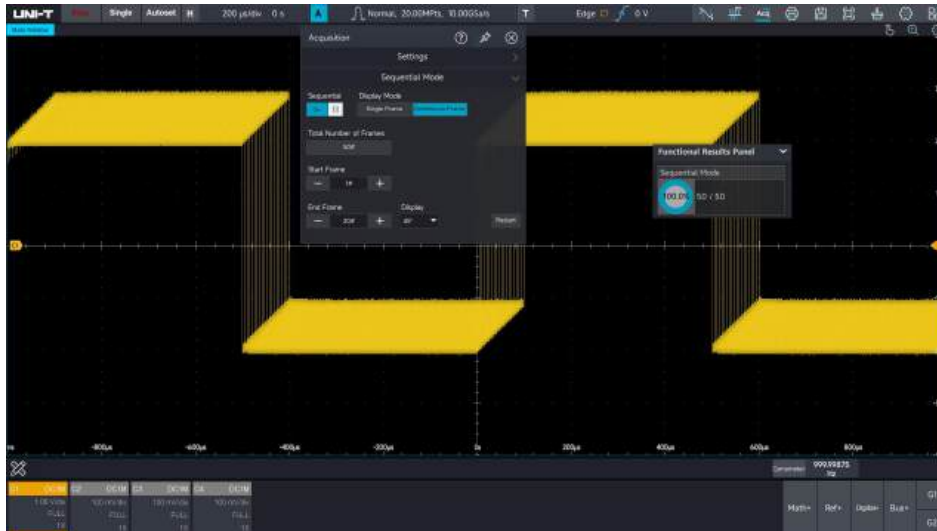

17.2 Single Frame Mode

In single frame mode, the reference frame can be displayed, the acquired waveform can be played back and the acquisition can be carried out again. When the total frame is set or the total frame changes, the waveform that has been collected will be collected again. The oscilloscope will enter the stop state after the acquisition reach to the set total frame. At this point, a frame within the acquired range can select to be the reference frame and it can playback. The reference frame displays a different color to distinguish it from the other waveform's frame. You can also set the playback interval to control the speed of waveform playback. During the playback, it can stop at any time if you found something usual, and you can click **-** or **+** to input the frame number to check the waveform.

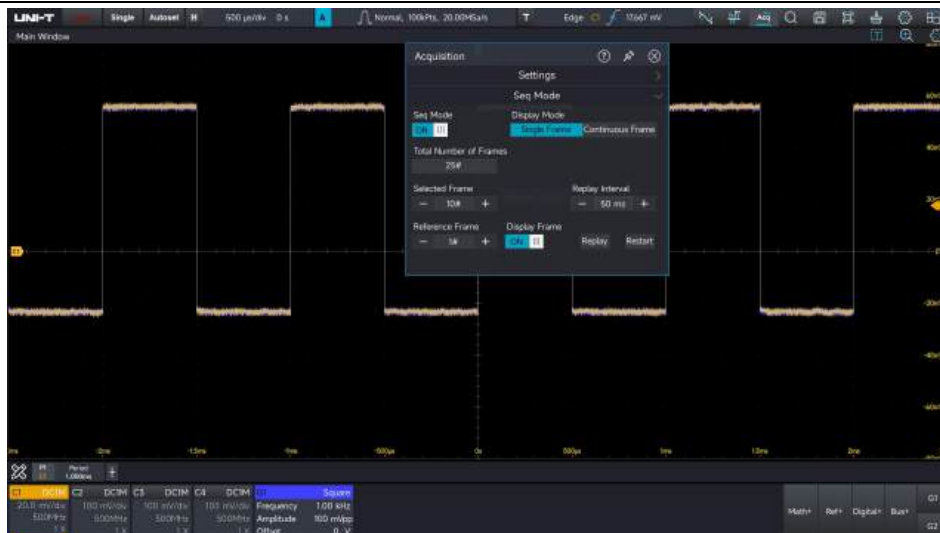

17.3 Consecutive Frame

In consecutive frame, the display range and display type of waveform can be set.

The display range of waveform can set 1#-20#, and the display mode can select 45°, stacking, superposition and stitching.

Take display range of maximum 20 frame as an example to demonstrate the waveform in different display type.

45°

The waveform in the range is displayed in an oblique upward direction of 45°.

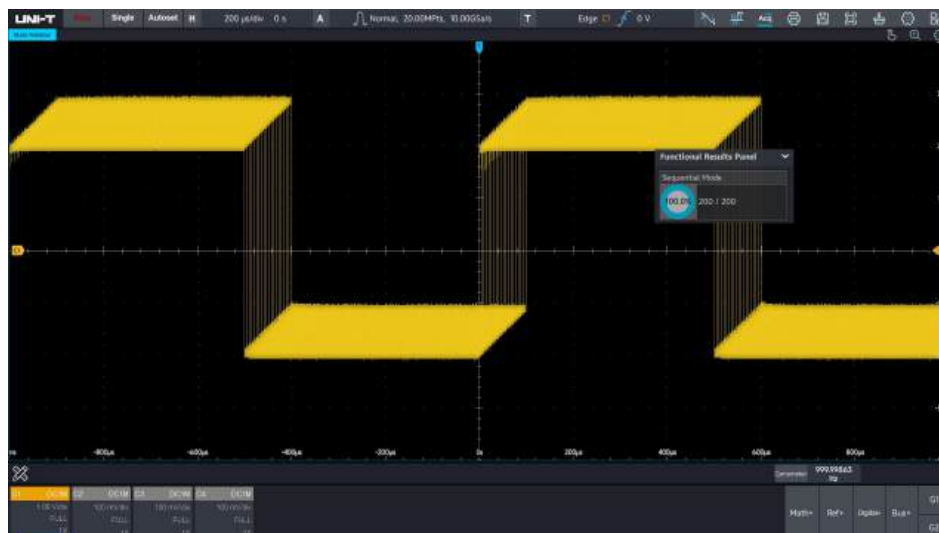

Stacking

The waveform in the range is stacked vertically to display.

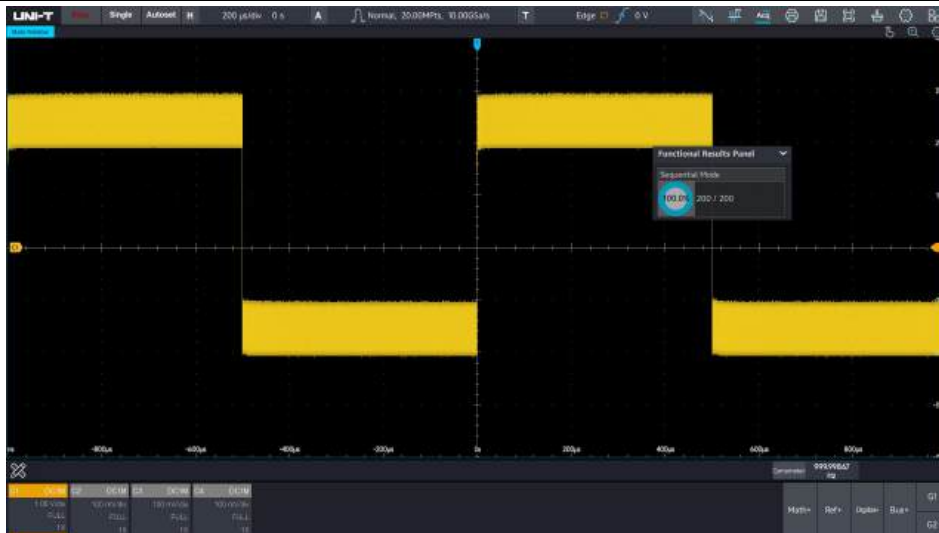

Superposition

The waveform in the range is superposed to one waveform to display.



Stitching

The waveform in the range is displayed in the first splicing.

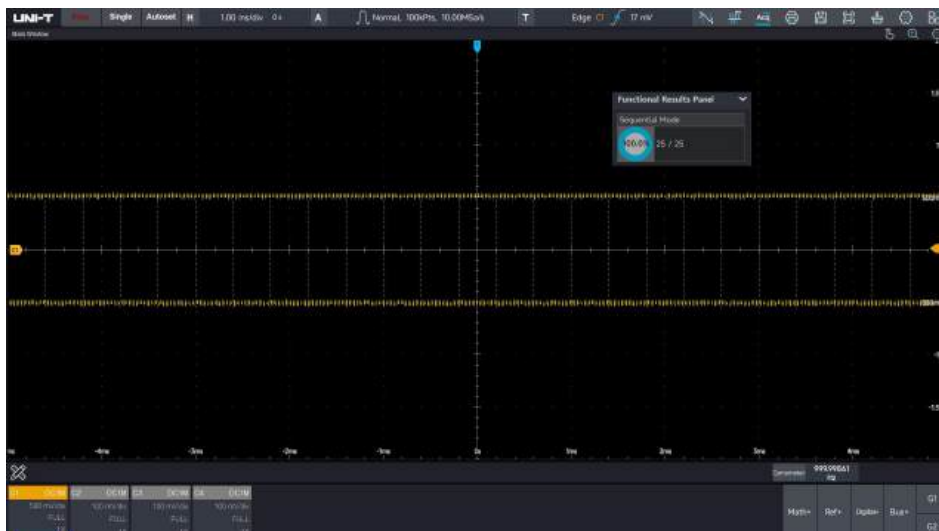

18. XY Mode

The waveform displayed in XY mode is also called Lissajous curve.

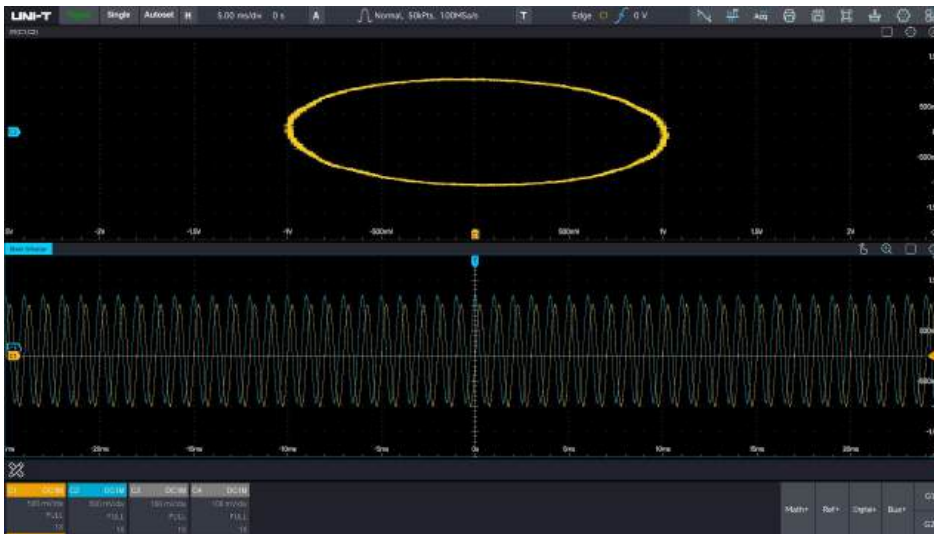

(1) Quickly produce a Lissajous curve

Using touch gesture to tap the icon  in start menu, click the Lissajous curve menu to quickly produce a Lissajous curve. Before generating, input signal on the horizontal axis (X axis) and input signal on the vertical axis (Y axis) should be set. (Such as X axis is set to C1, Y axis is set to C2).

(2) Adjust Lissajous waveform

- When X axis is selected (C1), using the “Position” rotary knob in vertical control area to move the Lissajous curve on horizontal direction.
- When Y axis is selected (C2), using the “Position” rotary knob in vertical control area to move the Lissajous curve on vertical direction.
- When X axis is selected (C1), using the “Scale” rotary knob in vertical control area to zoom out the Lissajous curve on horizontal direction.
- When Y axis is selected (C2), using the “Scale” rotary knob in vertical control area to zoom out the Lissajous curve on horizontal direction.
- Press the “Position” rotary knob in vertical control area to move the Lissajous curve to the center, so as to obtain a better display effect of Lissajous curve.

(3) X-Y tag

Click the mark tag  in the upper right corner of the X-Y mode to enable the marking function of X-Y. It supports marking waveforms and cursors. After enabling the marking function, the cursor function is also enabled simultaneously.

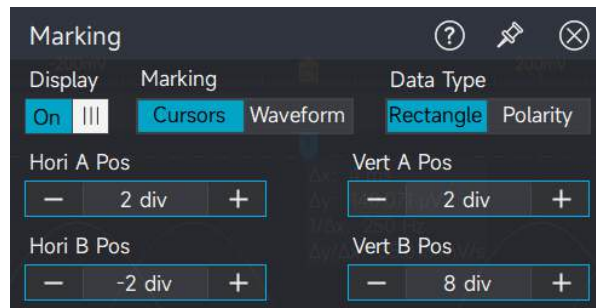

Waveform mark

Select the marking type as waveform. At this time, the scale mark is on the generated Lissajous figure. The marking position can be changed by adjusting the vertical scale/vertical displacement, horizontal scale/horizontal displacement or directly moving the cursor. Among them, A displays the marking position of cursor A, and B displays the marking position of cursor B (waveform marking only supports horizontal cursors).

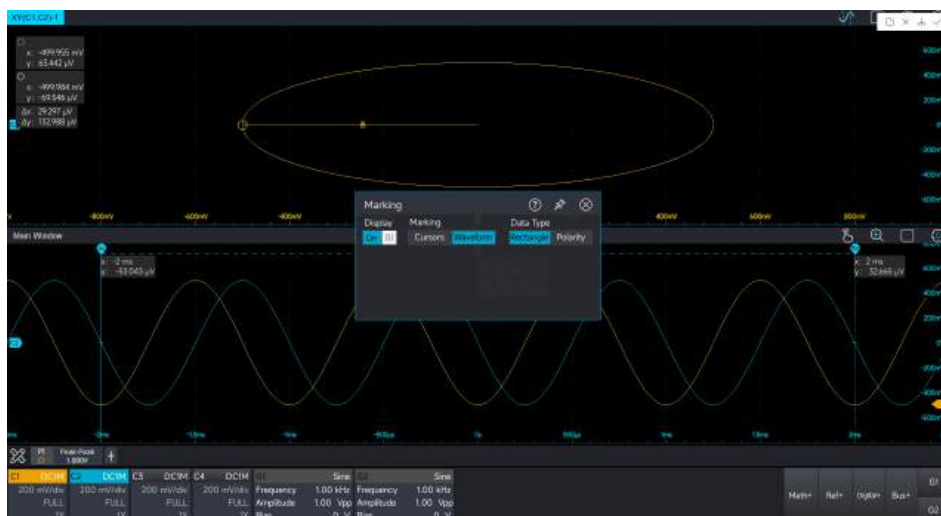

Cursor mark

Select the marking type as cursor. At this time, the scale mark is on the cursor of the generated Lissajous figure. The marking can be repositioned by moving the horizontal cursors Ax and Bx, and the vertical cursors Ay and By, and the cursor measurement can be performed simultaneously.

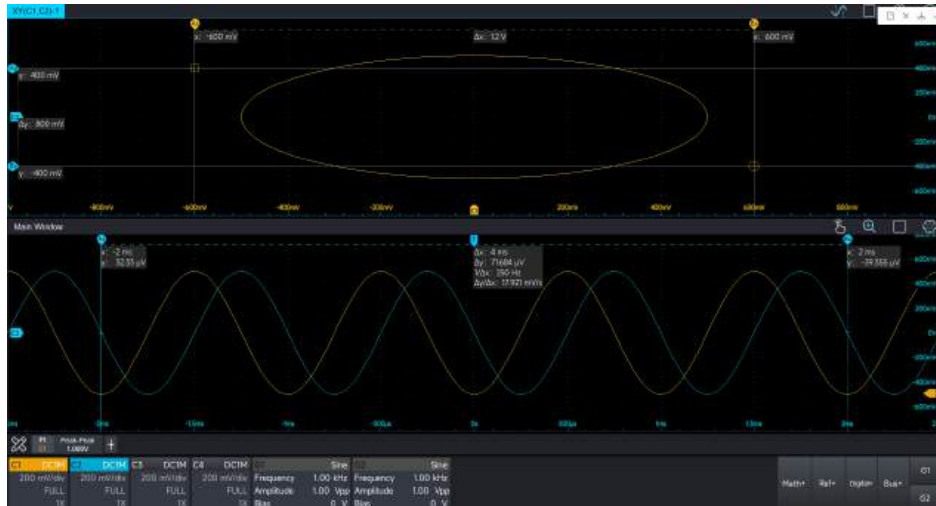

X-Y Data type

Rectangle: It represents the amplitude value of the normal cursor measurement. Cursor A measures the voltage value of the horizontal axis that constitutes the Lissajous figure, and Cursor B measures the voltage value of the vertical axis that constitutes the Lissajous figure.

Polarity: Measurement of polar coordinate values.

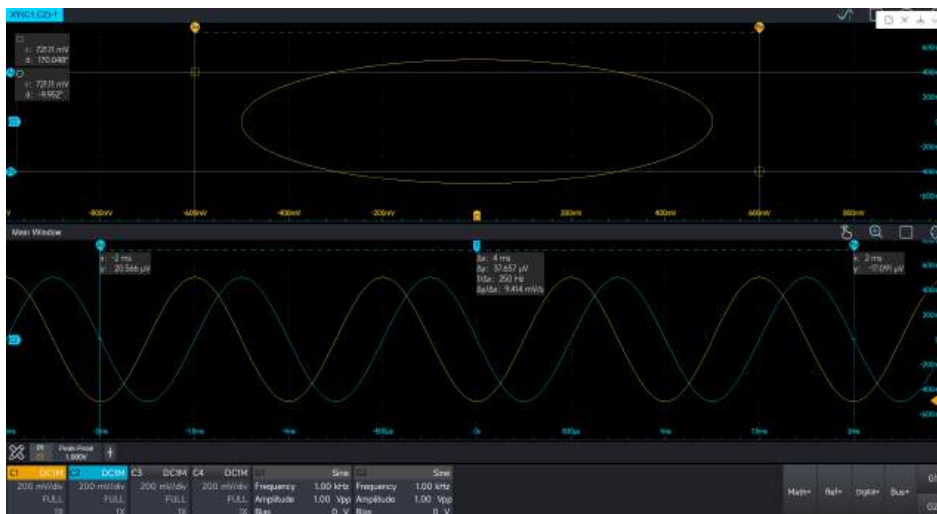

(4) Application of XY Mode

The phase difference between in two signals with the same frequency can be easily observed through Lissajous curve.

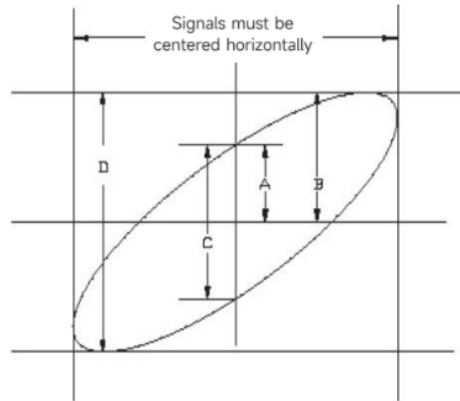

Based on $\sin\theta=A/B$ or C/D , θ is the phase angle between channels, the definition of A, B, C, D see above figure. Therefore, the phase angle is $\theta=\pm\arcsin(A/B)$ or $\theta=\pm\arcsin(C/D)$.

If the main spindle of elliptical is within I, III quadrant, then the acquired phase angle should at I, IV quadrant, that is within $(0 \sim \pi/2)$ or $(3\pi/2 \sim 2\pi)$.

If the main spindle of elliptical is within II, IV, then the acquired phase angle should within $(\pi/2 \sim \pi)$ or $(\pi \sim 3\pi/2)$.

In addition, if the frequency or phase difference of the two signal to be measured are integer times, calculating the frequency and phase relation of the two signals based on the figure.

Phase difference angle \ frequency ratio	0	$\frac{1}{4}\pi$	$\frac{1}{2}\pi$	$\frac{3}{4}\pi$	π
1:1					
1:2					
1:3					
2:3					

19. Histogram

- [Statistical Histogram](#)
- [Regional Histogram](#)

MSO8000HD series supports histogram analysis for tendency judgment, it is convenient for users to observe the waveform and the probability distribution of measurement parameters, and quickly find potential signal anomalies. The histogram includes statistical histogram and regional histogram. Statistical histogram counts the number of samples of the waveform measurement parameters. Regional histograms counts the waveform data on vertical and horizontal direction. This chapter will introduce how to use the histogram analysis function.

19.1 Statistical Histogram

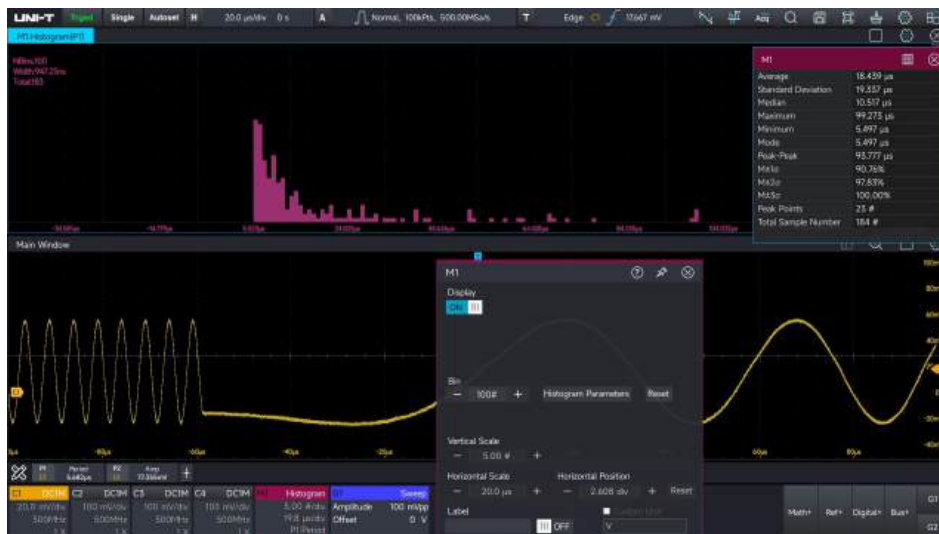

Turn on/off statistical histogram

- (1) Turn on statistical histogram: using touch gesture to tap to select the parameter to be count (parameter measurement need to tick), select the histogram in amplitude figure.
- (2) Turn off statistical histogram: using touch gesture to sliding down the histogram operation channel at the bottom of screen or select no in amplitude figure to turn off statistical histogram.

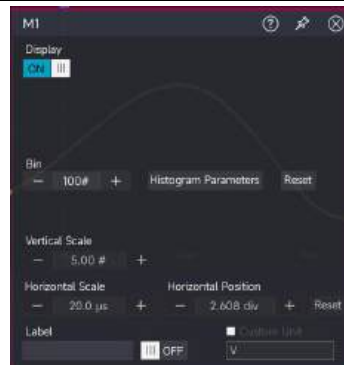

Set the cylinder number of histogram



When the histogram is opened, using touch gesture to tap the histogram operation channel at bottom of screen, and set cylinder in setting menu, the range can set 2~2k.

Set the vertical scale and horizontal scale

The vertical scale and horizontal scale of histogram represents the vertical axis and horizontal axis of statistical histogram. The unit of horizontal axis represents the unit of the current measuring parameter. For example, when the frequency is counting, the unit is Hz; when the amplitude is counting, the unit is V. The vertical axis represents the number of cylinder, the more the cylinder, the probability of its unit the higher.

Caution: It can be set to automatic, so the oscilloscope can automatically set the vertical scale and horizontal scale of histogram.

Set the vertical position and horizontal position

The vertical position and horizontal position of histogram can be adjusted by clicking  and , the unit is div.

Histogram parameter list

The histogram parameter list can be opened in setting menu. The parameter includes average, standard deviation, middle value, maximum, minimum, mode, peak-to-peak, $\mu \pm 1\sigma$, $\mu \pm 2\sigma$, $\mu \pm 3\sigma$, peak count and total sample.

M1	
Average	18.439 μ s
Standard Deviation	19.337 μ s
Median	10.517 μ s
Maximum	99.273 μ s
Minimum	5.497 μ s
Mode	5.497 μ s
Peak-Peak	93.777 μ s
$M \pm 1\sigma$	90.76%
$M \pm 2\sigma$	97.83%
$M \pm 3\sigma$	100.00%
Peak Points	23 #
Total Sample Number	184 #

Set the histogram label and customized unit

(1) Histogram label

Using touch gesture to tap the setting box below “label”, the screen will pop out the numerical keyboard, using the numerical keyboard to naming the label, the label’s color is consistent with the setting menu of histogram.

(2) Customized unit

Using touch gesture to tap the white box in front of “customized unit”, and click the setting box below “customized unit”, the screen will pop out the numerical keyboard, using the numerical keyboard to set the customized unit.

19.2 Regional Histogram

The regional histogram conducts probability statistics in the vertical and horizontal directions of the waveform, which can quickly help users analyze potential anomalies in the signal.

By using the touch gesture to click  on the rectangle in the upper right corner of the channel window, a rectangle can be drawn on the oscilloscope screen. You can select any line on the rectangle through the touch gesture and drag it to change the rectangle range. While the histogram is open, histogram columns will be displayed in the horizontal and vertical directions. The larger the rectangle range, the wider the statistical range.

The color of each channel regional histogram is consistent with the channel color.

C1: yellow



C2: blue



C3: green



C4: purple



20. Function/Arbitrary Waveform Generator (Option)

- [Turn on/off Function/Arbitrary Waveform Generator](#)
- [Output Continuous Wave Signal](#)
- [Output Modulating Signal](#)
- [Output Sweep Frequency Signal](#)

MSO8000HD series has a built-in dual-channel function/arbitrary waveform generator, with a maximum output frequency of up to 60 MHz, using direct digital synthesis technology to produce accurate and stable waveform output. Dual-channel of function/arbitrary waveform generator are equal performance output. This chapter uses G1 channel as an example, the operation of G2 channel is same as G1 channel.

20.1 Turn on/off Function/Arbitrary Waveform Generator

- Touch method

ON: Using touch gesture to tap the label of “G1/G2” function/arbitrary waveform generator in the right lower corner  to turn on “G1/G2”, and click the channel to enter the signal output menu.

OFF: Using touch gesture to sliding down to turn off the signal generator channel.

- Key method

ON: Press the **Gen** key on “Function” area in the front panel to directly open dual channel of function/arbitrary waveform generator.

OFF: In the open state, press the **Gen** key on “Function” area in the front panel again to close the function/arbitrary waveform generator.



20.2 Output Continuous Wave Signal

- (1) Turn on continuous wave output

In signal output setting menu, click to switch to continuous wave.

- (2) Set waveform parameter

The continuous wave can select sine wave, square wave, impulse wave, triangular wave, sawtooth wave, noise, DC, Sinc, exponential rising, exponential falling, Lorentz, haversine, Gaussian, ECG (electrocardiograph) and arbitrary wave.

The arbitrary wave can select arbitrary wave file to save the waveform output.

The following table shows all wave type and its parameter.

Sine wave	Frequency, cycle, amplitude, high-low level, offset
Square wave	Frequency, cycle, amplitude, high-low level, offset
Impulse wave	Frequency, cycle, amplitude, high-low level, offset, duty cycle, rising time, falling time
Triangular wave	Frequency, cycle, amplitude, high-low level, offset
Sawtooth wave	Frequency, cycle, amplitude, high-low level, offset, symmetry
Noise	Amplitude, offset, high-low level
DC	Offset
Sinc	Frequency, cycle, amplitude, high-low level, offset
Exponential rising	Frequency, cycle, amplitude, high-low level, offset
Exponential falling	Frequency, cycle, amplitude, high-low level, offset
Lorentz	Frequency, cycle, amplitude, high-low level, offset
Haversine	Frequency, cycle, amplitude, high-low level, offset

Gaussian	Frequency, cycle, amplitude, high-low level, offset
ECG	Frequency, cycle, amplitude, high-low level, offset
Arbitrary wave	Frequency, cycle, amplitude, high-low level, offset, select arbitrary wave

■ Output frequency

In signal setting menu, using touch gesture to tap “frequency” to pop out the numerical keyboard, and then to set the frequency and unit. Different waveforms can be set with different frequency ranges. For the specific frequency range, please refer to the MSO8000HD Series Mixed Signal Oscilloscopes -Datasheet.

■ Cycle

In signal setting menu, using touch gesture to tap “cycle” to pop out the numerical keyboard, and then to set the cycle and unit. For the specific frequency range, please refer to the MSO8000HD Series Mixed Signal Oscilloscopes -Datasheet.

Caution: The relation of frequency and cycle is reciprocal, so the cycle will be changed after the corresponding frequency is set; on the contrary, the frequency will be changed after the period is set.

■ Amplitude

In signal setting menu, using touch gesture to tap “amplitude” to pop out the numerical keyboard, and then to set the amplitude and unit.

The amplitude range can set 20 mV~6V.

■ High-low level

In signal setting menu, using touch gesture to tap “high-low level” to pop out the numerical keyboard, and then to set the high-low level and unit.

Caution: The range of high-low level can set -3V~3V. Amplitude =|high level|+|low level|, when adjusting the high/low level, the amplitude will change accordingly.

■ Offset

In signal setting menu, using touch gesture to tap “offset” to pop out the numerical keyboard, and then to set the offset and unit.

Offset range: -3V~3V

■ Duty cycle of impulse wave

In signal setting menu, using touch gesture to tap “duty cycle” to pop out the numerical keyboard, and then to set the duty cycle.

Range of duty cycle: 0.01% ~ 99.99%

Caution: Duty cycle is only useful in impulse wave.

- Rising/falling time of impulse wave

In signal setting menu, using touch gesture to tap “rising/falling time” to pop out the numerical keyboard, and then to set the rising/falling time.

Range of rising/falling time: 5ns~2s.

Caution: Rising/falling time is only useful in impulse wave.

- Symmetry of sawtooth wave

In signal setting menu, using touch gesture to tap “symmetry” to pop out the numerical keyboard, and then to set the symmetry.

Range of symmetry: 0.01% ~ 99.99%

- Arbitrary wave output

In signal setting menu, using touch gesture to tap “arbitrary wave”, and then to select the arbitrary wave file in saved file folder of arbitrary wave.

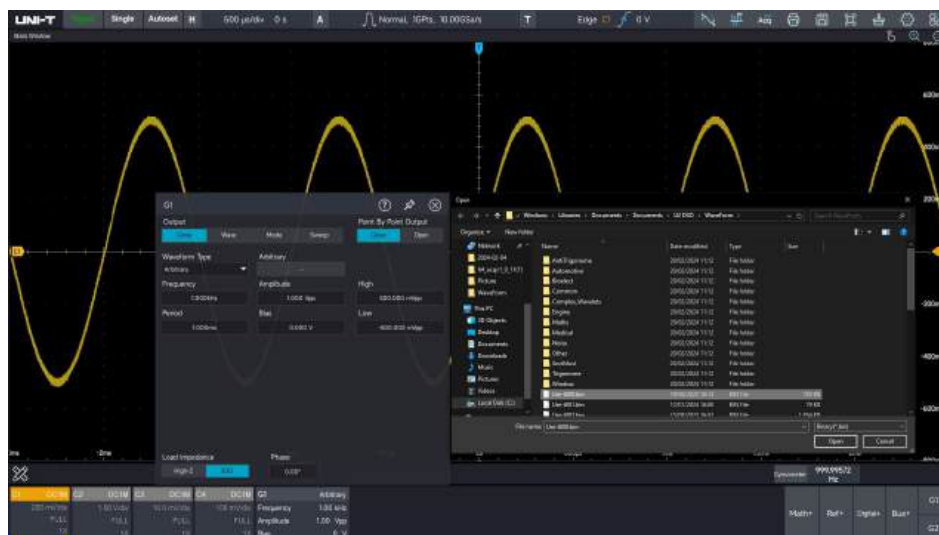

After loading the arbitrary wave, output frequency and amplitude of arbitrary wave can be set.

- Impedance

The load impedance can switch to “High-Z” and “50Ω”. In “High-Z” state, the output amplitude of the signal generator is 2 times of “50Ω”. To avoid the amplitude testing error caused by the signal generator is not match with the impedance of other test device, please refer the following formula to switch the impedance.

$$VBNC = VHighz * \frac{R(external)}{50\Omega + R(external)}$$

- Start phase

Open G1 and G2, and respectively inputs signal to two analog channel of C1 and C2. One of the channels is used as the reference channel to adjust the start phase of the other channel.



20.3 Output Modulating Signal

- Output AM signal

In AM mode, the modulated waveform is consist of carrier wave and modulating wave, the amplitude of carrier wave will change with the amplitude of modulating wave. The modulation modes of the two channels are independent of each other.

This section uses a fundamental wave (sine wave of 10kHz, 1Vpp), modulating wave (sine wave, modulating frequency of 1kHz, modulating depth of 100%) as an example.

(1) In signal output setting menu, click to switch to modulating wave.

(2) Select the waveform type

The modulating source is come from internal. The fundamental wave can select sine wave, square wave, impulse wave, sawtooth wave and arbitrary wave. For waveform parameter setting, please refer to the section of [“Output Continuous Wave Signal”](#). The waveform is set to sine wave of 10kHz, amplitude of 1V.

(3) Select the modulating type as AM

(4) Select modulating wave

The modulating wave can select sine wave, square wave, impulse wave, sawtooth wave and arbitrary wave. The modulating wave is set to sine wave.

(5) Select modulating frequency

Range of modulating frequency: 2mHz~200kHz. The modulating frequency is set to 1kHz.

(6) Select modulating depth

Range of modulating depth: 0%~120%. The modulating depth is set to 100%.

The modulating depth indicates the change of amplitude, which expressed by percentage. The range of AM modulating depth is 0% ~ 120%, the default setting is 100%. When the modulating depth is set to 0%, it outputs a constant amplitude (which is a half of the carrier amplitude). When the modulating depth is set to 100%, the output amplitude will change with the modulating wave. When the modulating depth is greater than 100%, the output amplitude of instrument will not over 3V (the load is 50Ω).



■ Output FM signal

In FM mode, the modulated waveform is consist of carrier wave and modulating wave, the frequency of carrier wave will change with the amplitude of modulating wave.

This section uses a fundamental wave (sine wave of 10kHz, 100mV), modulating wave (square wave, modulating frequency of 2kHz, frequency offset of 5kHz) as an example.

(1) In signal output setting menu, click to switch to modulating wave.

(2) Select the waveform type

The fundamental wave can select sine wave, square wave, impulse wave, sawtooth wave and arbitrary wave. For waveform parameter setting, please refer to the section of "[Output Continuous Wave Signal](#)". The waveform is set to sine wave of 10kHz, amplitude of 100mV.

(3) Select the modulating type as FM

(4) Select modulating wave

The modulating wave can select sine wave, square wave, impulse wave, sawtooth wave and

arbitrary wave. The modulating wave is set to sine wave.

(5) Select modulating frequency

Range of modulating frequency: 2mHz~200kHz. The modulating frequency is set to 1kHz.

(6) Set frequency offset

The frequency offset indicates the deviation of the frequency of the FM-modulated waveform with respect to the carrier frequency.

Range of FM frequency offset: $0 \leq \text{frequency of fundamental wave} \pm \text{modulating frequency} \leq \text{system bandwidth}$

The frequency offset is set to 5kHz.

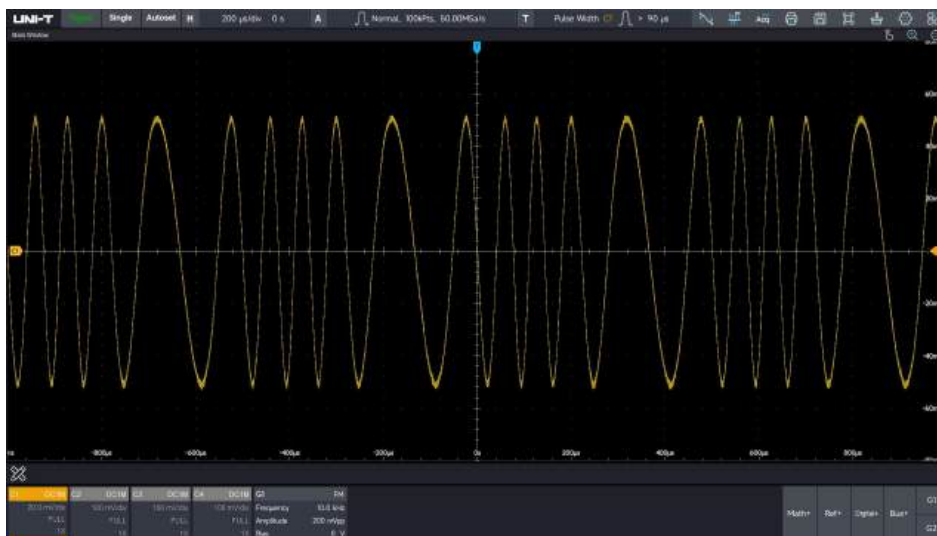

■ Output PM signal

In PM mode, the modulated waveform is consist of carrier wave and modulating wave, the phase of carrier wave will change with the amplitude of modulating wave.

This section uses a fundamental wave (sine wave of 500kHz, 1Vpp), modulating wave (square wave, modulating frequency of 50kHz, phase offset of 5kHz) as an example.

(1) In signal output setting menu, click to switch to modulating wave.

(2) Select the waveform type

The fundamental wave can select sine wave, square wave, impulse wave, sawtooth wave and arbitrary wave. For waveform parameter setting, please refer to the section of "[Output Continuous Wave Signal](#)". The waveform is set to sine wave of 50kHz, amplitude of 1V.

(3) Select the modulating type as PM

(4) Select modulating wave

The modulating wave can select sine wave, square wave, impulse wave, sawtooth wave and

arbitrary wave. The modulating wave is set to sine wave.

(5) Select modulating frequency

Range of modulating frequency: 2mHz~200kHz. The modulating frequency is set to 50kHz.

(6) Set phase offset

The phase offset indicates the deviation of the phase of the PM-modulated waveform with respect to the carrier frequency.

Range of PM phase offset: $0^{\circ} \sim 360^{\circ}$, the default setting is 180° .

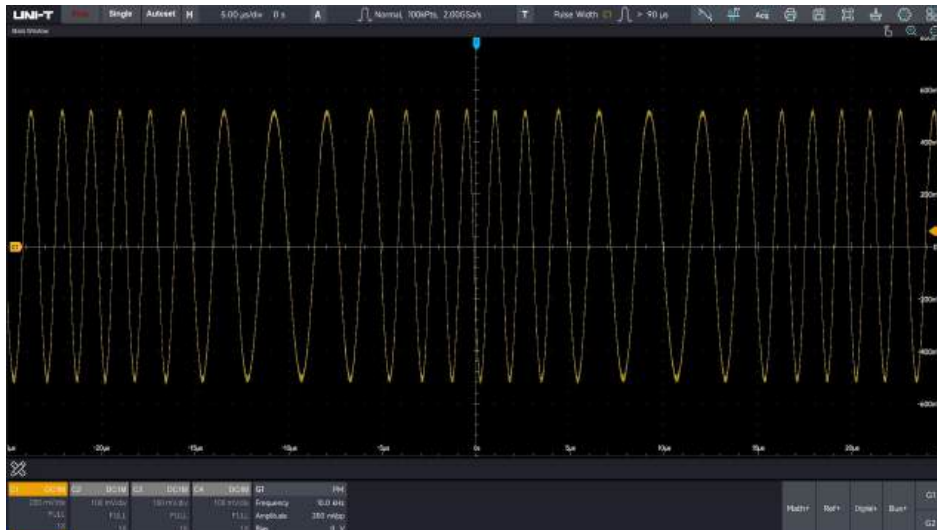

20.4 Output Sweep Frequency Signal

In sweep frequency mode, the instrument will change the output frequency within the specified sweep-frequency time, and the output frequency will be change from the starting frequency to stop frequency in linearity or logarithm method.

The sine wave, square wave, sawtooth wave and arbitrary wave can generate sweep frequency (except DC).

This section uses a square wave of 1Vpp, duty cycle of 50% as the sweep-frequency wave (the sweep-frequency mode is linear, starting frequency is 1kHz, stop frequency is 50kHz, sweep-frequency time is 2ms) as an example.

(1) In signal output setting menu, click to switch to sweep-frequency.

(2) Select the waveform type

The fundamental wave can select sine wave, square wave, sawtooth wave and arbitrary wave.

For waveform parameter setting, please refer to the section of “[Output Continuous Wave Signal](#)”. The fundamental wave is set to square wave of 1V, duty cycle of 50%.

(3) Select the sweep-frequency type

Linearity: changing the output frequency in linear method, that is “Hz/second”

Logarithm: changing the output frequency in logarithmic method, that is “octave/second” or “10 time/second”.

(4) Select sweep-frequency time

Using the numerical keyboard to set sweep-frequency time and the range is 1ms~500s. The sweep-frequency time is set to 2ms.

(5) Set trigger source

Internal: the oscilloscope’s built-in clock is used as the trigger source to start the sweep frequency.

External: the external clock needs to be connected, and the sweep frequency will be started when the rising/falling edge of the external clock is detected. The external clock is connected via 10M Ref IN port on the rear panel.

For more details, please refer to the section of “[Rear Panel](#)”.

The trigger source is set to internal.

(6) Set start/stop frequency

The starting frequency and stop frequency is the upper and lower limit of sweep frequency. The arbitrary waveform generator scans the output from the specified “starting frequency” to “stop frequency” and back to “starting frequency”. The starting frequency is set to 1kHz, and the stop frequency is set to 50kHz.

- Starting frequency < stop frequency, the arbitrary waveform generator scans the output from low frequency to high frequency.
- Starting frequency > stop frequency, the arbitrary waveform generator scans the output from high frequency to low frequency.
- Starting frequency = stop frequency, the arbitrary waveform generator is output at a fixed frequency.

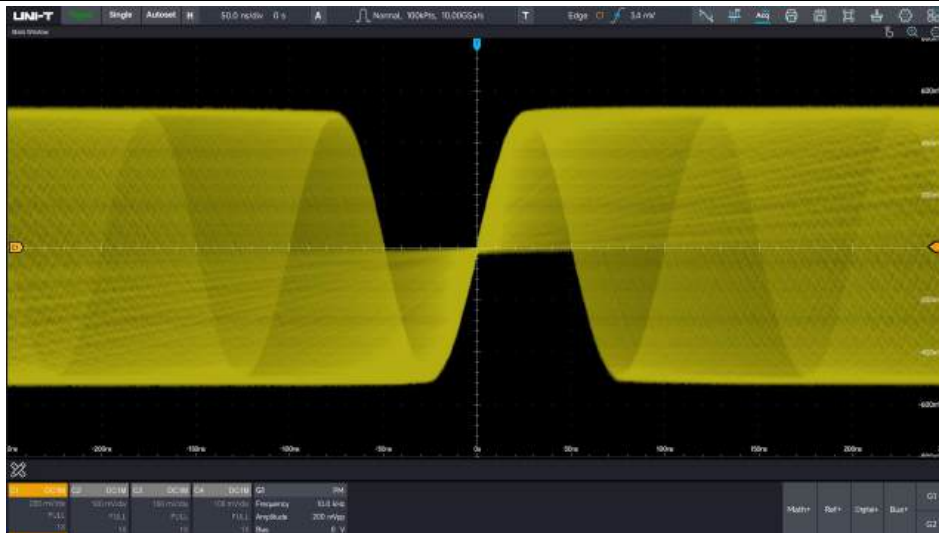

21. Search and Navigation

The search function can help users quickly find the concerned events and mark them, and then quickly locate the marked signals to be viewed with the help of event navigation. The search conditions that can be set for waveform search include edge and pulse width. The navigation function allows users to quickly view and locate waveforms. You can click the icon  in the upper right corner of the screen to enter the search function.

Setting search type:

Search type can be setting: edge and pulse width, The following takes edge search as an example to introduce the complete search function.

Setting the source:

The search source can be chose: C1-C4、EXT、AC、AuxIn、D0-D15。

Setting the edge:

The edge can be chose: rise edge/fall edge/any edge

Setting the search level:

Specific level values can be input through the numeric keypad, or the level values can be modified through.

Search copied to trigger:

Copy the set search conditions to the trigger and use the search conditions for triggering.

Trigger copied to search:

Copy the trigger conditions to the search and use the trigger conditions for searching.

Add multiple search:

Click the icon on the upper right of the screen again to add multiple searches. The MSO8000HD supports up to 10 searches.

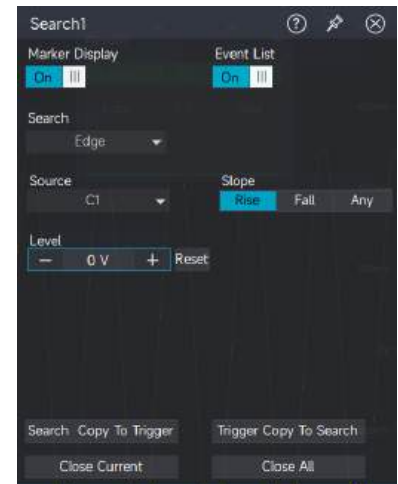

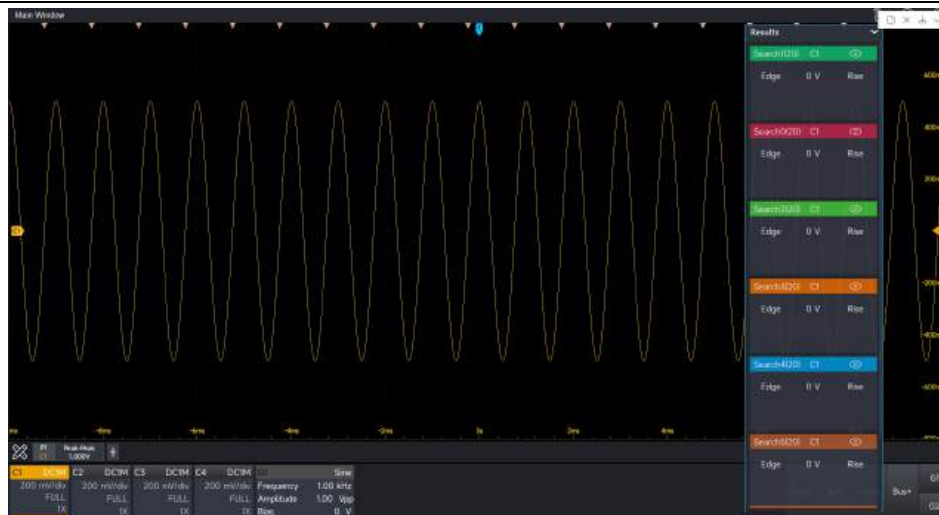

Close search:

By swiping right on the search item, you can directly close the current search item, or click to close the current item or close all items in the search settings menu to close the search.

Search tag

Different search items are marked with inverted triangles of different colors. Click the eye icon in the upper right corner of the search item to set whether the search mark is displayed or not.

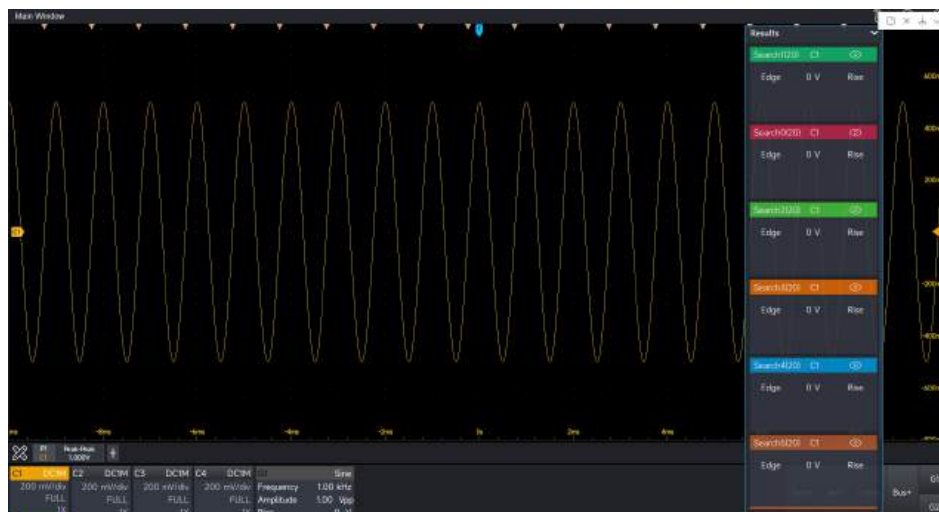

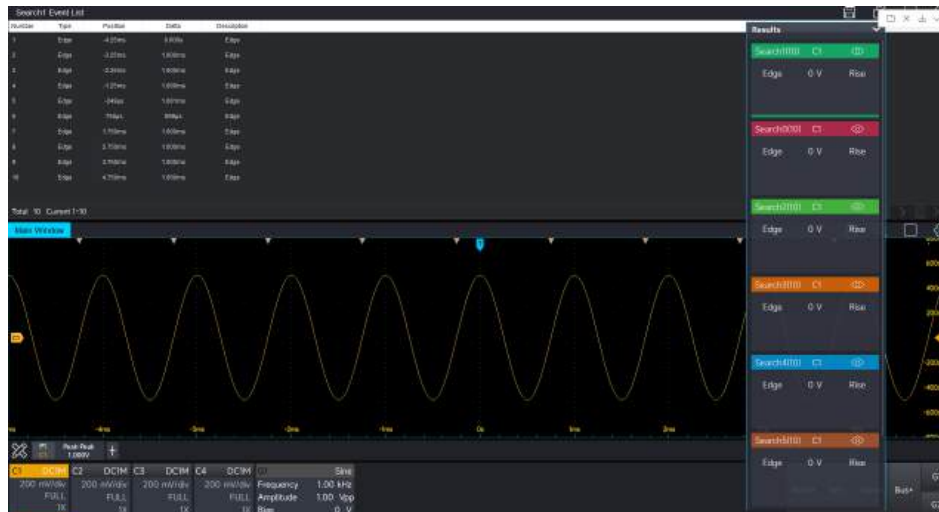

Search event list

The search event list can display all the waveform information searched on the screen, and the number of searches will also be displayed in the upper left of the search item. The event list information includes event number, search type, location (with timestamp), interpolation, and description. Click on different search items to switch to the corresponding event list.



Sequential navigation

In the stopped state, navigation can be performed on the searched waveforms. Click the  and  icons at the lower end of the search item in the stopped state for sequential navigation.

During navigation, the oscilloscope automatically opens the window expansion to maximize the display of the waveform.

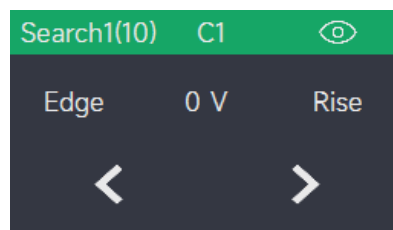

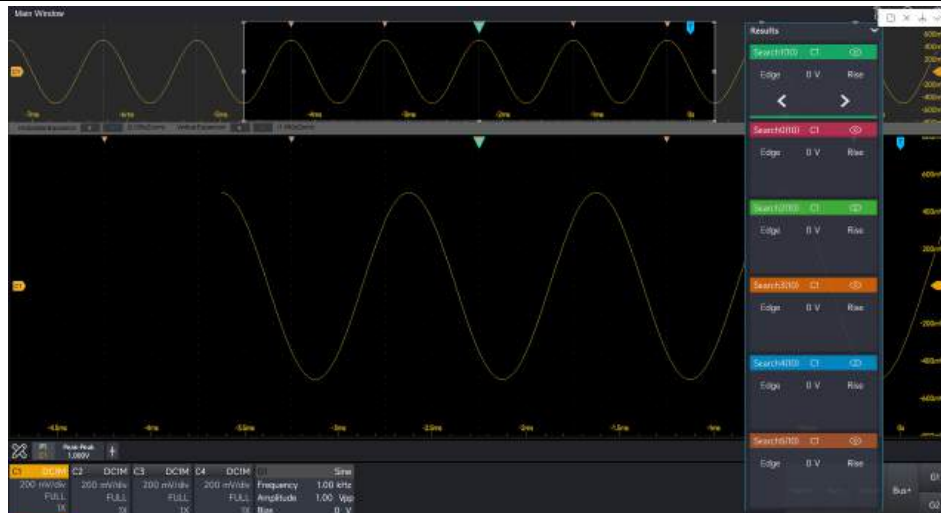

Event navigation

In the stopped state, you can click on a certain event in the search event list to navigate the searched waveform. When navigating, the oscilloscope automatically opens the window expansion to maximize the display of the waveform.

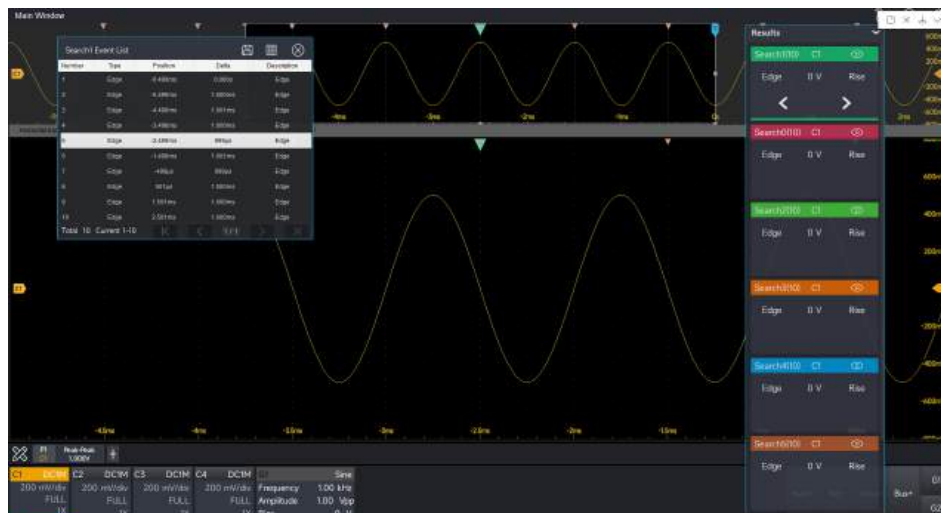

22. Window Display Setting

- [Marker display](#)
- [Persistence](#)
- [Grid Type](#)
- [Waveform Type](#)
- [Brightness](#)

The primary window can set the marker position of waveform, persistence, grid type, wave type and brightness.

Caution: In other independent window, the persistence cannot be set and UltraAcq® mode cannot be open.

22.1 Marker Display

(1) Enabling marker display

In window display menu, enabling the marker display, and turn on/off the vertical marker display.

(2) Adjusting marker position

Vertical marker position: it can be display at the left or right side

Horizontal marker position: it can be display at the upper or lower side



22.2 Persistence

Persistence display can visualize the waveform changes under high refresh rate, which is helpful for preliminary analysis of abnormal waveform changes.

MSO8000HD series has two persistence mode, automatic and infinite.

- Automatic: the waveform persistence will be automatically adjusted by the oscilloscope.
- Infinite: when the oscilloscope collects a new waveform, it does not clear the old waveform, the newly acquired waveform has a higher brightness, and the acquired waveform has a slightly lower brightness. Infinite persistence can quickly analyze the approximate range of noise and jitter, and capture the probability event effectively in the high refresh state.

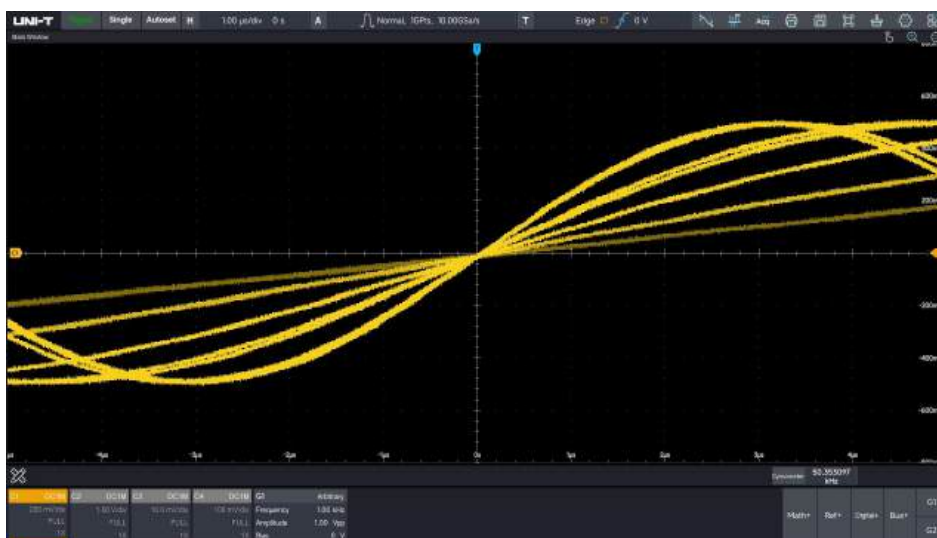

22.3 Grid Type

MSO8000HD series has three grid types, which is full, simple and none.

Simple

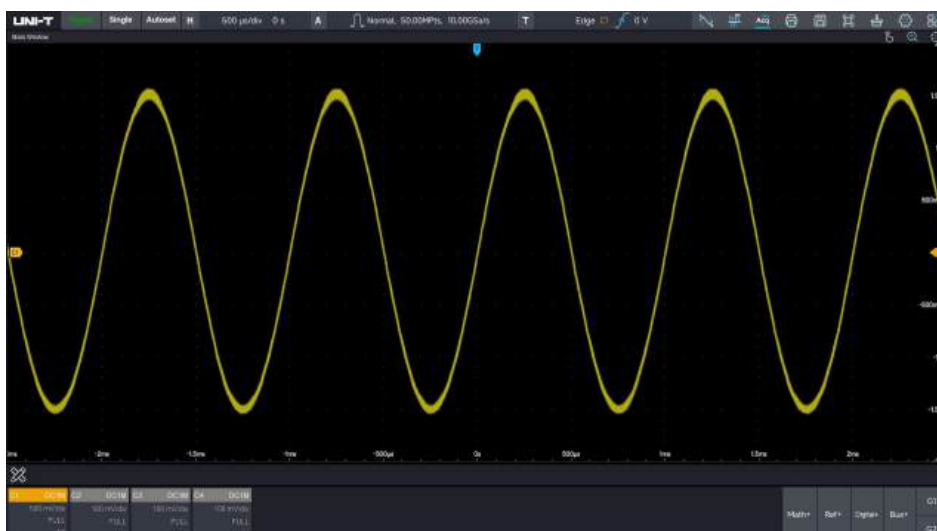

Full



None

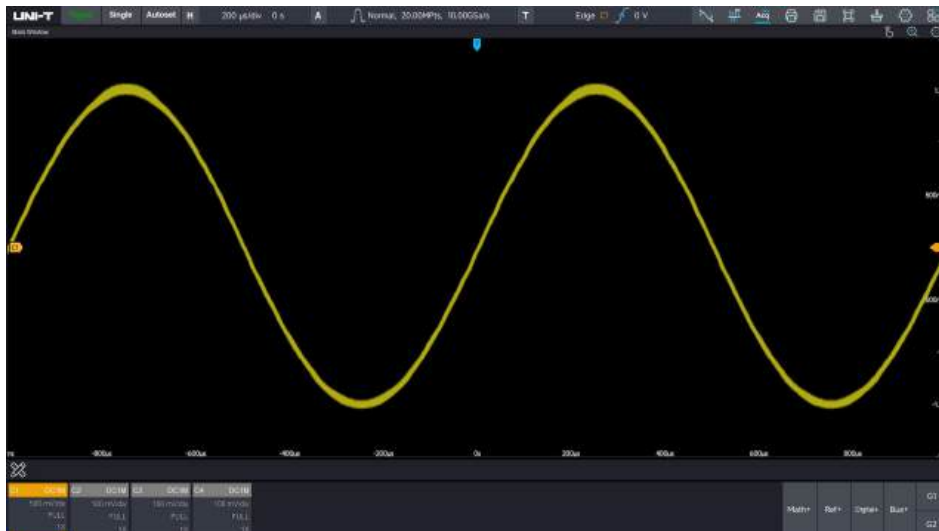

22.4 Waveform Type

In window display menu, the waveform type can select vector and dot.

Vector: in most cases, this mode provides the most realistic waveforms, making it easy to see the sharp edges of waveforms (such as square wave).

Dot: the sampling point can be displayed directly.

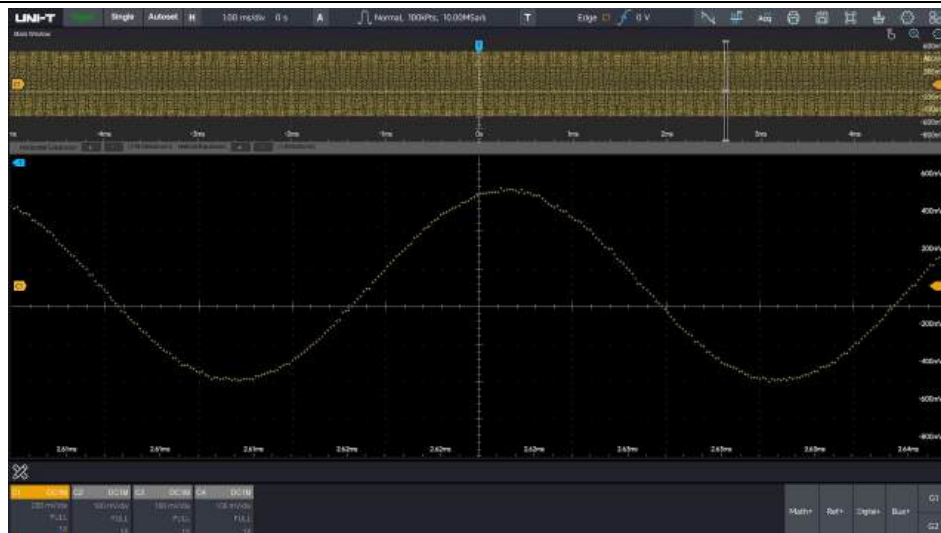

22.5 Brightness

Adjusting waveform brightness

The waveform brightness can be adjusted by using touch gesture to sliding the waveform brightness bar to right or left.

The progress bar displays the current value 1~100.



Adjusting grid brightness Grid

The grid brightness can be adjusted by using touch gesture to sliding the grid brightness bar to right or left.

The progress bar displays the current value 1~100.

23. Storage and Print

- [Waveform Storage and Reloading](#)
- [Screen Image Storage](#)
- [Storage Setting and Reading](#)
- [External Storage and Loading](#)
- [Data export](#)

The storage function is used to save the oscilloscope's waveform and screen image to internal memory or external USB. MSO8000HD provides four USB Host ports for connecting external storage device. MSO8000HD can reload the saved settings and waveforms when needed, clicking the storage icon  in the top right corner of the screen to enter the storage function menu.

23.1 Waveform Storage and Reloading

Waveform Storage

(1) Storage format

MSO8000HD series supports 7 waveform formats, which are Binary (.bin), Text (.txt), Matlab (.mat), Excel (.xlsx), CSV (.csv), TSV (.tsv), DAT (.dat).

Text (.txt) includes 5 text formats of ASCII, GB2312, UTF8, UTF32 and Unicode.

(2) Save channel's waveform of different source

MSO8000HD only supports to save four analog C1~C4 channel's waveform.

(3) Save input filename

Click the name to pop out soft keyboard to input the filename and save it.

Suffix of date: It will save the file that named with the current system date, such as Uni-t00120231010163554902.bin

(4) Storage location

Click the icon  to select the storage location. When clicking "Save", the filename is existed and it will pop out a hint box "File already exists, whether to overwrite it?". The user can select overwrite or retype the filename of saved file.

(5) Open file location

The oscilloscope will turn to the directory of image storage.

Waveform reloading

MSO8000HD only supports reload the waveform with format of .bin/.csv. If clicking save & reload, it will reload the waveform and simultaneously save it.

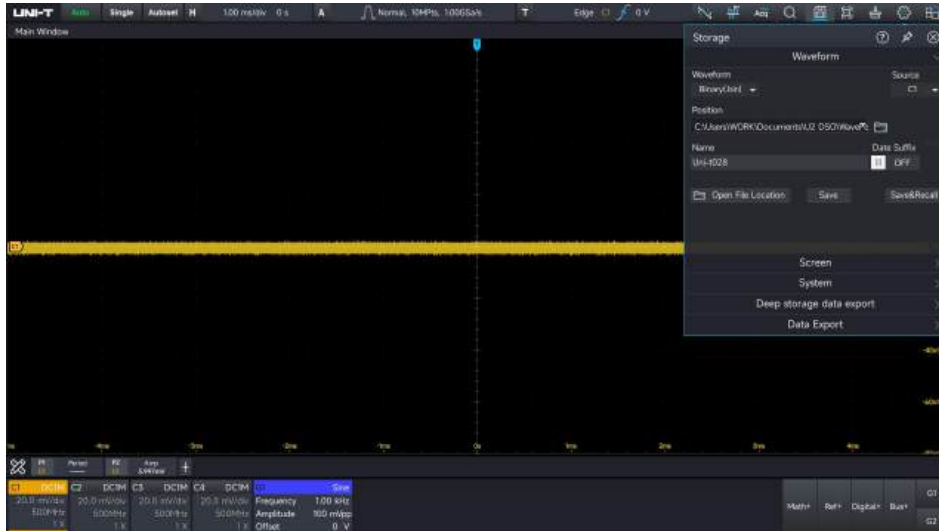

23.2 Screen Image Storage

In storage setting menu, clicking “Screenshot” to enter the screen image storage page.

(1) Select screenshot area

MSO8000HD supports two types of area screenshots: screen capture and grid.

(2) Select image color

MSO8000HD supports three types of picture processing: standard, black and inverse color.

Description of image storage

Function	Setting	Description
Color	Standard	The oscilloscope screenshot is stored in the colors displayed on the interface.
	Inverse color	The oscilloscope screenshot converts the dark background to light color for storage, It is for saving ink when print the screenshot.
	Black and white	The oscilloscope screenshot converts the color image to grey-scale image for storage.
Area	Screen	The oscilloscope screenshot is stored with full screen information.
	Grid	The oscilloscope screenshot is only stored with grid

		information.
--	--	--------------

(3) Select storage type of image

MSO8000HD supports five image format (.bmp, .tiff, .gif, .png, .jpeg).

(4) Timestamp

Enabling the timestamp will add a time watermark to the lower - right corner of the saved image.

(5) Storage location

Click the icon  to select the storage location. When clicking “Save”, the filename is existed and it will pop out a hint box “File already exists, whether to overwrite it?”. The user can select overwrite or retype the filename of saved file.

(6) Save & Skip

Click save & skip, the oscilloscope will turn to the directory of image storage after save the image.

(7) Open file location

The oscilloscope will turn to the directory of image storage.

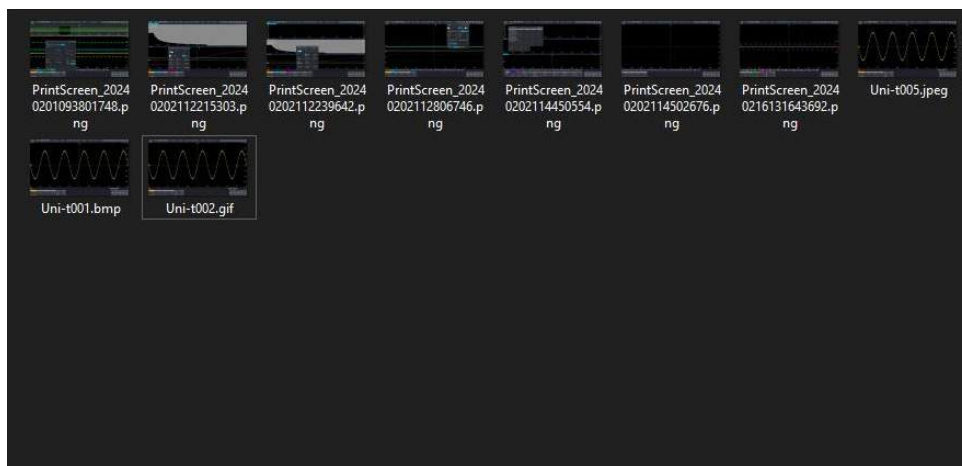

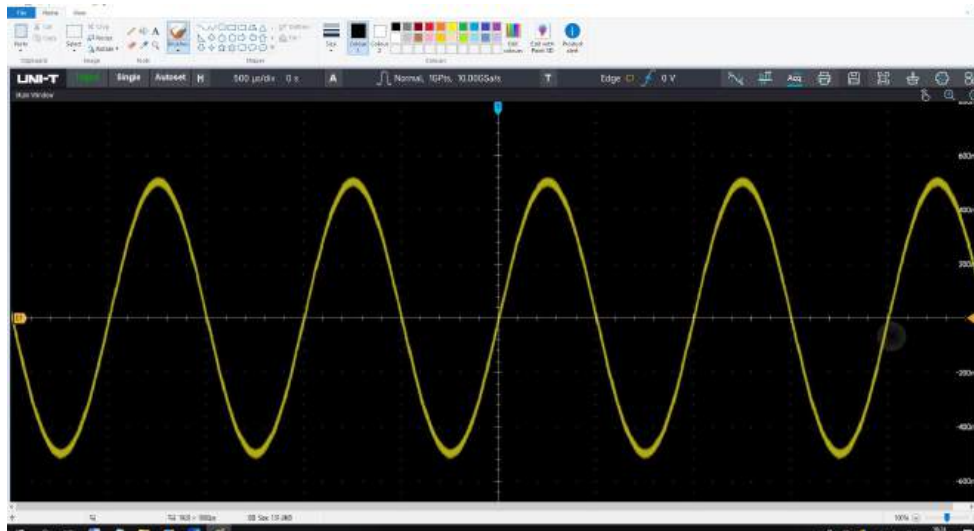

Hint: MSO8000HD series supports quick save, press the key  on the front panel, the oscilloscope will save the image to the saved path by default.

23.3 Storage Setting and Reading

In storage setting menu, clicking the system setting to enter the system setting page. The oscilloscope stores the oscilloscope's setup file in .set format, which is convenient for users to recall the saved setup file next time, and helpful for quickly restore the oscilloscope to the last use state (e.g. QC test).

(1) Storage location

Click the icon  to select the storage location. When clicking "Save", the filename is existed and it will pop out a hint box "File already exists, whether to overwrite it?". The user can select overwrite or retype the filename of saved file.

(2) Save & Skip

Click save & skip, the oscilloscope will turn to the directory of image storage after save the image.

(3) Open file location

The oscilloscope will turn to the directory of image storage.

(4) Reading

The oscilloscope reads the saved setup file to restore the state to the previous.

Hint: MSO8000HD series can read the setup file from local directory and can also save and read from external storage device.

23.4 Deep Storage Data Export

MSO8000HD series supports save the waveform, screenshot and setup file to external via USB and also supports reload waveform and setting from USB.

(1) Select the file format.

The deep storage of MSO8000HD supports two waveform formats for saving: Binary (.bin) and Text (.txt).

(2) Enter the saved file name.

Click on the name, and a soft keyboard will pop up for you to input the saved file name.

Date suffix: When saving, the file will be named with the current system date. For example: Uni - t00120231010163554902.bin.



(3) Select the save location

Click the  icon to select the save location. When you click "Save", if the name already exists, a prompt selection box will pop up, prompting the user "The file already exists. Do you want to overwrite it ?" The user can choose to overwrite or re - enter the saved file name.

(4) Click to save deep - storage data.

MSO8000HD saves the waveform data in the memory according to the currently set storage depth. The number of saved points is the same as the storage depth.

23.5 External Storage and Loading

The MSO8000HD series supports storing waveforms, screenshots, and setting files to an external device via a USB drive. It also supports loading waveforms and settings from an external storage device.

(1) Identify the removable storage device (take a USB flash drive as an example)

When a USB flash drive is inserted, the oscilloscope detects the removable storage device and pops up a window to remind the user, asking whether to use the external storage device as the save path. If the user clicks "No", the oscilloscope will default the local storage path as

the device save path. After setting the external storage device as the save path, waveforms, screenshots, and setting files can be stored in the file directory of this device.

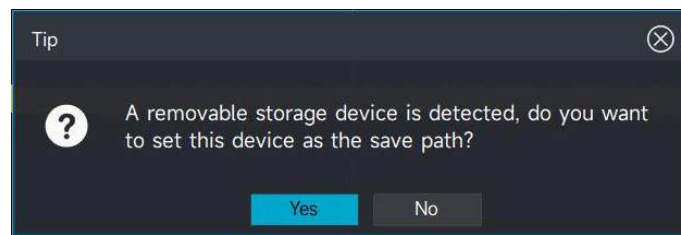

After setting the external storage device as the save path, a folder will be automatically created on the external storage device, such as E:\MSO8804X\Picture.

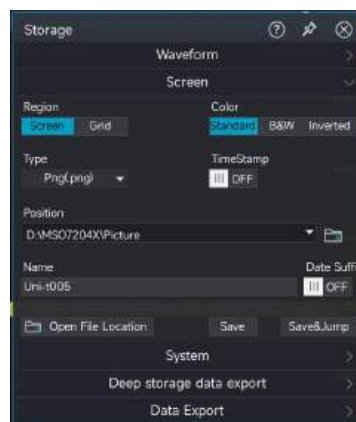

(2) Loading of reference waveforms from external storage path

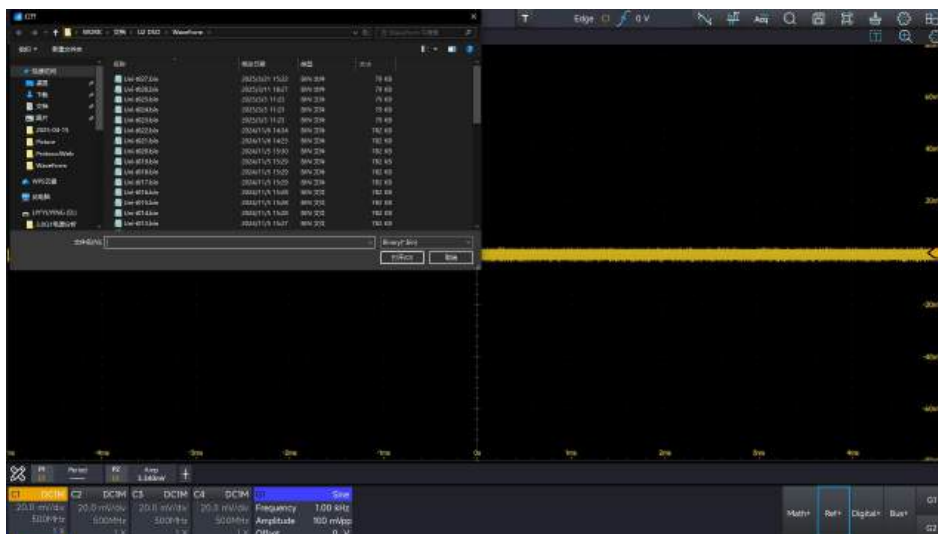

Click "Reference +" at the lower - right corner of the oscilloscope desktop, and the waveform storage path will pop up automatically. Select the saved.bin file in the directory of the storage disk, and click "OK" to recall the reference waveform



24. System Setting

- [Display Setting](#)
- [Automatic Setting and Calibration](#)
- [Communication](#)
- [Auxiliary Input and Output](#)
- [Other Setting](#)

Enter system setting

- (1) Using touch gesture to tap the setting icon  in top right corner or enter the start menu to click the icon  to enter the system setting.
- (2) Click the Function control area on the front panel, press **Utility** to enter the system setting.

24.1 Display Setting

Screen brightness

The screen brightness can be adjusted by dragging the screen brightness. The range is 5~100.

Default brightness is 90%.

Screen contrast ratio

The screen contrast ratio can be adjusted by dragging the screen brightness. The range is 50~100.

Default brightness is 70%.

24.2 Automatic Setting and Calibration

Automatic Setting

MSO8000HD has a fast Autoset mode, Autoset will automatically set the vertical settings, horizontal settings, acquisition settings, trigger settings, coupling hold, channel settings and stacked display according to the input signals, so that the waveforms are displayed stably on the screen. Users can tick (tick) or (not tick) these settings to let the oscilloscope perform fast Autoset according to your choice.

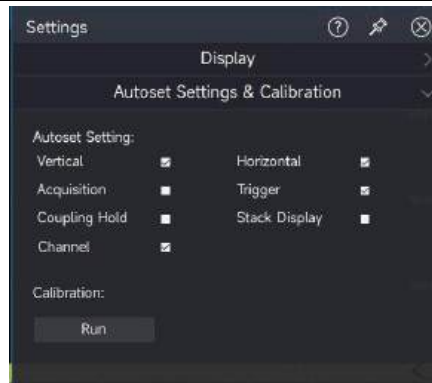

Calibration

The calibration function enables the oscilloscope to reach the optimal working condition for acquiring the most accurate measurement value. The user can perform this function at any time, especially when the ambient temperature range varies within 5°C or more, before performing the auto-calibration operation, please make sure that the oscilloscope is powered on and running for more than 20 minutes.

24.3 Communication

(1) Network

Before using LAN bus, connect the oscilloscope to LAN via network cable. The oscilloscope's network port is on the rear panel. The user can check the current network setting and configured network parameter in the system setting page.

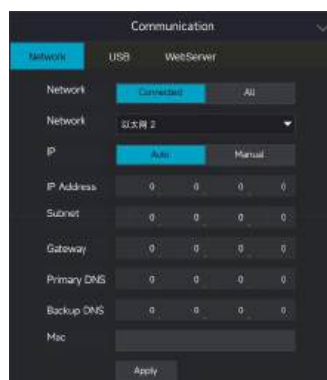

(1) Network Selection

- IP address

The format of IP address is nnn.nnn.nnn.nnn. The first “nnn” can set to 0~255 (except 127), and the valid range is 0~223, and the other three “nnn” range is 0~255.

- Subnet mask

The format of subnet mask is nnn.nnn.nnn.nnn, the range of “nnn” is 0~255.

- Gateway

In static IP mode, the gateway can be set. The format of gateway is nnn.nnn.nnn.nnn. The first “nnn” can set to 0~223, and the other three “nnn” range is 0~255.

- DNS (domain name system)

In static IP mode, DNS can be set. The format of DNS is nnn.nnn.nnn.nnn. The first “nnn” can set to 0~223, and the other three “nnn” range is 0~255. In generally, the user do not need to set DNS in the network.

- MAC address

For an oscilloscope, MAC address is always unique. When assigning an IP address to an instrument, the instrument is always identified by its MAC address. After configuring the network information, click “IP” to change the IP address, or click “DHCP” to get the IP address automatically.

(2) USB

USB can display the manufacture’s ID, product ID, serial number and the currently used VISA address. The oscilloscope can directly connect to a PC via USB DEVICE on the rear panel for communication without configuration parameter.

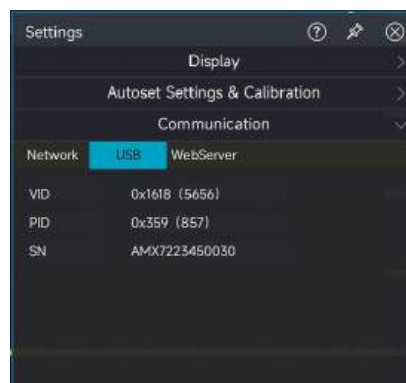

(3) WebServer: WebServer displays the switch state of current network. The default network port: 80.

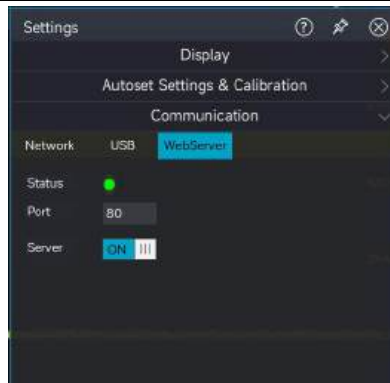

For WebServer remote control, please refer to the chapter of [“WebServer Remote Control”](#).

24.4 Auxiliary Input and Output

MSO8000HD series has multiple interface and equipped with auxiliary input and output for signals. These function can be set in the system setting menu.

Auxiliary Input Signal

Triggering synchronization: Set the clock signal of external input as the triggering synchronization, the signal is input via the Aux In port in the rear panel.

AWG external trigger: Set the external input signal as the AWG external trigger signal, the signal is input via the Aux In port in the rear panel.

Auxiliary Output Signal

Triggering synchronization: Set the instrument's clock 10 MHz as the triggering synchronization, the signal is input via the Aux In port in the rear panel.

AWG external trigger: Set the external input signal as the AWG external trigger signal, the signal is input via the Aux In port in the rear panel.

Pass/Fail test: The result of pass/fail test will output by impulse signal, the signal is output via the Aux Out port. For more details, please refer to the section of [“Pass/Fail Test”](#).



24.5 Self Test

Screen self - test: Click "Click Start" to enter the screen self - test interface. Press any key on the keyboard panel (except Run/Stop) or rotate any knob to switch the screen color. Press Run/Stop three times in a row to exit the screen self - test.



Touch detection: Click "Click Start" to enter the touch detection interface. Click any small square on the interface, and if the square turns blue, it indicates that the touch is effective. Press Run/Stop three times in a row to exit the touch detection.



Keyboard detection: Click "Click Start" to enter the keyboard detection interface. Press a key on the keyboard panel or turn a knob. If the corresponding key or knob on the test interface turns green, it means the key or knob is working properly. Press Run/Stop three times in a row to exit the keyboard detection.

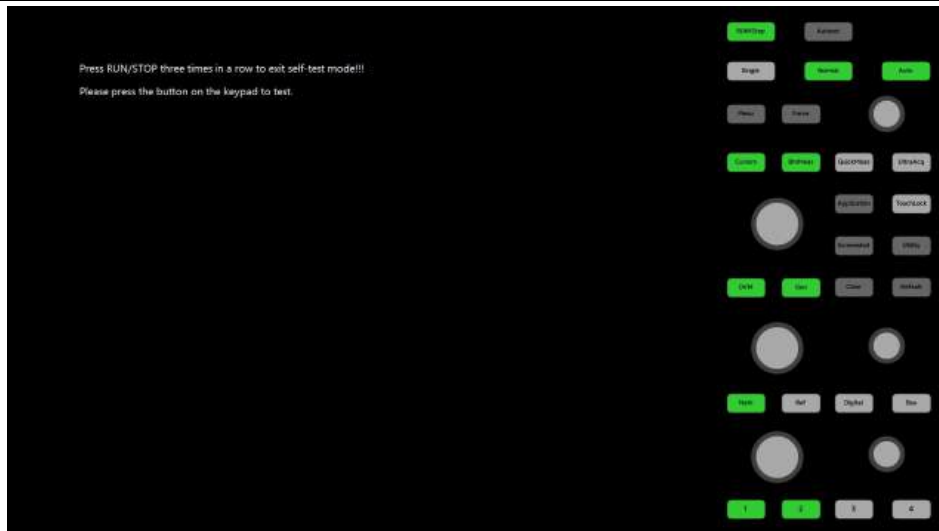

24.6 Other Setting

Other setting includes modifying the channel's color, set time, language, restoring factory setting and touch lock.



Modifying the channel's color

- (1) Select the channel that need to change color: M1~M8, D0~D15, B1~B2, AWG1~AWG2
- (2) Click "Color" on the right side to pop out the color selection window. Changing the channel's color by the color panel. It can select standard color or user-defined color.

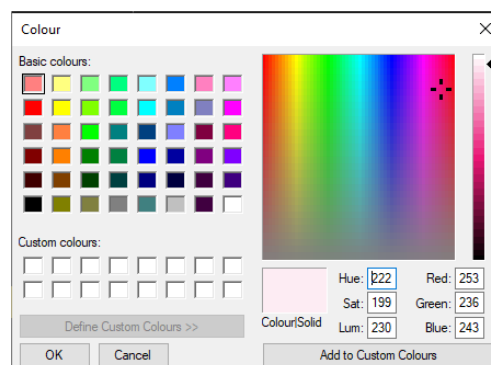

Set time

The time format is “year: month: day: hour: minute: second”.

Set language

MSO8000HD supports simplified Chinese, English, German, French, Spanish and Italian.

Default setting

Click “Reset” to restore to the instrument to the factory setting, or press the “Default” key in Function area to reset it. After press it, it will prompt “Whether reset to the factory setting?” on the screen, select “Yes” to reset it.

The factory setting status of the MSO8000HD series mixed-signal oscilloscope is shown in the following table:

Module	Function	Setting
Time base setting	Horizontal scale	1us/DIV
	Delay	0 (that is, the midpoint of the horizontal)
Acquisition settings	Acquisition mode	Normal
	Average - Times	8
	10MHz clock in	Internal
	Memory depth	Auto
	Interpolation method	Sine
	UltraAcq	Close
	ERes	OFF
	ERes	0.5
	Sequence mode	Close
	Sequence mode-Display mode	Single frame
	Sequence mode-start frame	1

	Sequence mode-Ref frame	1
	Sequence mode-current frame	1
	Sequence mode-Display type	None
Trigger setting	Trigger type	Edge
	Trigger mode	Auto
	Source	C1
	Level	0
	Coupling	DC
	Edge type	Rise edge
	Edge-EXT-Input impedance	1M Ω
	Pulse width-source	C1
	Pulse width-level	0
	Pulse width-polarity	Positive
	Pulse width-condition	>
	Pulse width - Lower limit of pulse width	3.2ns
	Pulse width - Upper limit of pulse width	3.6ns
	Video - Source	C1
	Video - Standard	PAL
	Video - Polarity	Positive
Video - Synchronization	Even field	

	Video - Line	1
	Video - Level	0
	Slope - Source	C1
	Slope - Slope	Rise
	Slope - Condition	>
	Slope - Low level	0V
	Slope - High level	0.1V
	Slope - Lower Time Limit	3.2ns
	Slope - Upper Time Limit	3.6ns
	Runt - source	C1
	Runt - Polarity	Positive
	Runt - Condition	>
	Runt - Low level	0V
	Runt - High level	0.1V
	Runt - Lower Time Limit	3.2ns
	Delay - Edge of Source 1	Rise edge
	Delay - Edge of Source 2	Rise edge
	Delay - Source 1	C1
	Delay - Source 2	C2
	Delay - Condition	>
	Delay - Lower Time Limit	3.2ns
	Delay - Upper Time Limit	3.6ns

	Delay - Source 1 Level	0V
	Delay - Source 2 Level	0V
	Timeout - Source	C1
	Timeout - Edge	Rise
	Timeout - Level	0V
	Timeout - Duration	3.2ns
	Timeout - Condition	>
	Duration - Lower Time Limit	3.2ns
	Duration - Upper Time Limit	3.6ns
	Setup & Hold - Clock source	C1
	Setup & Hold - Data source	C2
	Setup & Hold - Clock edge	Rise edge
	Setup & Hold - Clock level	0V
	Setup & Hold - Pattern Setting	H
	Setup & Hold - Data level	0V
	Setup & Hold - Condition	Setup
	Setup & Hold - Setup time	3.2ns
	Setup & Hold - Hold time	3.2ns
	Nth edge - Source	C1
	Nth edge - Edge type	Rise edge
	Nth edge - Idle time	3.2ns
	Nth edge - Edge number	1

	Nth edge – Level	0V
	Holdoff time	6.4ns
Cursor setting	Display	Close
	Source	C1
	Data display	suspend
	Synchronous Movement	Close
	Type	Horizontal
	Position A of the horizontal level	-3.2div
	Position B of the horizontal level	3.2div
	Position A of the vertical level	1div
	Position B of the vertical level	9div
	Horizontal unit	Base
	Vertical unit	Second
Print setting	direction	horizontal
	Area	Full screen
	Color	Standard
Save setting	Save-Waveform-Waveform format	bin
	Save-Waveform-Source	C1

	Save-Waveform-Address	C:\Users\Administrator\ Documents\U2 DSO\WaveForm
	Save-Waveform-Name	Uni-t000
	Save-Waveform- Date suffix	Off
	Save-Screenshot- Area	Screen
	Save-Screenshot- Color	Standard
	Save-Screenshot- Type	.png
	Save-Screenshot- Address	C:\Users\Administrator\ Documents\U2 DSO\Picture
	Save-Screenshot- Name	Uni-t000
	Save-Screenshot- Date suffix	Off
	Save - System settings - Save - Address	C:\Users\Administrator\ Documents\U2 DSO\Setting
	Save - System settings - Save - Name	Uni-t000
	Save - System settings - Save - Date suffix	Off
	Save - System settings - Read - Address	C:\Users\Administrator\ Documents\U2 DSO\Setting
Setting	Setting - Display - Screen brightness	100
	Settings - Display -	100

	Screen contrast	
	Settings - Autoset and corrections - Self-settings	Vertical settings, Horizontal settings, Acquisition settings, Trigger settings, Channel settings
	Setting- Aux in/out-Aux in	Off
	Setting- Aux in/out- Input polarity	Rise
	Setting- Aux in/out-Aux out	Off
	Setting- Aux in/out- output polarity	Rise
	Webserver	ON
Pass/fail test	Test	Off
	Source	C1
	Type	Limit test
	Vertical tolerance	200mdiv
	Horizontal tolerance	100mdiv
	Ref Source	C1
	Total Fail times	1
	Total number of waveforms	100
	Total time	1s
	Test failed operation	Save, Alarm, Pulse, Screen
	Display test mask	ON

	Standard	ANSI T1.102
	Lock the mask	Off
Jitter analysis	Open	Off
	Source	C1
	Signal type	Data signal
	Comparison threshold	50%
	Hysteresis	30%
	Data mode length	127bit
	Bit rate	(Nan bps) ---
	Clock recovery method	Constant
	PLL	Order I
	Cut-off frequency	(Nan bps) ---
	Cut-off coefficient	1667
	Graphic selection	Trace
	Spectrum decision threshold	50%
	The number of histogram columns	Num250
	Natural frequency	(Nan bps) ---
Damping factor	0.707	
DVM	Display	OFF
	Source	C1
	Auto range	OFF

	Mode	DC
Frequency counter	Display	OFF
Quick Meas	Display	OFF
	Source	C1
Parameter measurement	Display	OFF
	Measurement threshold	Screen
	Measurement statistics	OFF
Analog channel setting	Vertical - Display	C2、C3、C4 OFF
	Vertical - Inverse	OFF
	Vertical - Coupling	DC1M
	Vertical - Vertical Scale	200mV/div
	Vertical - Bandwidth limit	500MHz
	Vertical - Position	0
	Vertical - Unit	V
	Vertical - Offset	0V
	Vertical - Label	“ ”
	Vertical - Fine	OFF
	Input - Probe Magnification	1X
Input - Spare Units	OFF	
Ref setting	Display	OFF
Logic setting	Display	OFF

	Display Settings - Options - Channel	D0
	Display Settings - Options - Label	“”
	Display Settings - Height	Low
BUS	Display	OFF
AWG	Function	OFF
	Output	OFF
Math	Display	OFF
	Operation type	Basic operation
	Math-Basic operation-Source 1	C1
	Math-Basic operation-Source 1	C2
	Math-Basic operation- Operator	+
	Math-Basic operation- Vertical scale	Default to the latest gear position
	Math-Basic operation- Vertical Position	0div
	Math-Basic operation- Label	“”
	Math-Basic operation- Custom unit	V
	Display mark	ON

Display settings of the main window	Afterglow	OFF
	Vertical mark position	Right
	Horizontal mark position	Down
	Waveform style	Vector
	Grid style	Full
	Grid Brightness	10
	Waveform Brightness	65

Touch lock

Tap “touch lock” to close this function, it acquires rights of administrators.

25. Remote Control

- [User-defined Programming](#)
- [PC Software Control](#)
- [Web Server](#)

MSO8000HD series mixed signal oscilloscopes support a variety of remote control methods. This chapter describes in detail how to use NI-MAX software to remotely control the oscilloscope through various interfaces.

Caution: Before connecting the communication cable, it is necessary to turn off the instrument to prevent damage to the instrument's communication interface.

25.1 User-defined Programming

The user can perform the programming control on the oscilloscope through SCPI (Standard Commands for Programmable Instruments). For detailed descriptions on command and programming, please refer to MS07000X Series Mixed Signal Oscilloscope-Programming Manual.

25.2 PC Software Control

The user can send command to remotely control the oscilloscope via PC software. MSO8000HD series oscilloscope require NI-VISA connection.

Operating steps

- (1) Setup the communication between the instrument and PC
- (2) Open the 打开 NI-MAX software and search the instrument source
- (3) Open the remote control panel and send the command

The oscilloscope can communicate with a PC via the following interface.

LAN Control

- (1) Connect device

Connecting the oscilloscope to LAN via the network cable.

- (2) Configure network parameter

Refer to "[Communication](#)" to set the network parameter of oscilloscope.

(3) Check device

Open NI-MAX, click “Device and interface” to view the name of VISA, which corresponds to the communication address of the network in the instrument settings.

(4) Remote control

Right-click the source name, select “Open VISA Test Panel” to open the control panel of remote command, so that this panel can send command and read data.

(5) Loading LXI page

This oscilloscope can access the LXI web page by entering the instrument's IP address in a web browser. The web page displays a variety of important information about the instrument, including the instrument model, manufacturer, MAX address, and IP address.

USB Control

(1) Connect device

Connecting the oscilloscope to a PC via USB-type-B wire.

(2) Check device

Open NI-MAX, click “Device and interface” to view the name of VISA, which corresponds to the communication address of USB in the instrument settings.

(3) Remote control

Right-click the source name, select “Open VISA Test Panel” to open the control panel of remote command, so that this panel can send command and read data.

25.3 Web Server

WebServer displays the switch state of current network. The default network port is 80.

PC Access

The computer and the oscilloscope are required to be on the same LAN and can ping each other. The oscilloscope can access the local IP address through “Utility” or by clicking the setting icon  to view, and then the browser can access the oscilloscope by accessing port IP: 80.

Example

PC IP: 192.168.137.101, oscilloscope IP: 192.168.137.100, gateway: 192.168.137.1

The browser accesses the oscilloscope through IP: 192.168.137.100:80 for viewing the device information and remote control (as shown in the following figure.), SCPI control, export waveforms, and export documents.

Home page: Product model, manufacturer, serial number, firmware version, network and communication.



WebServer Home Page

Remote control

The instrument response can be controlled in webpage, it consistent with real instrument operation. It can operate full display and screenshot.

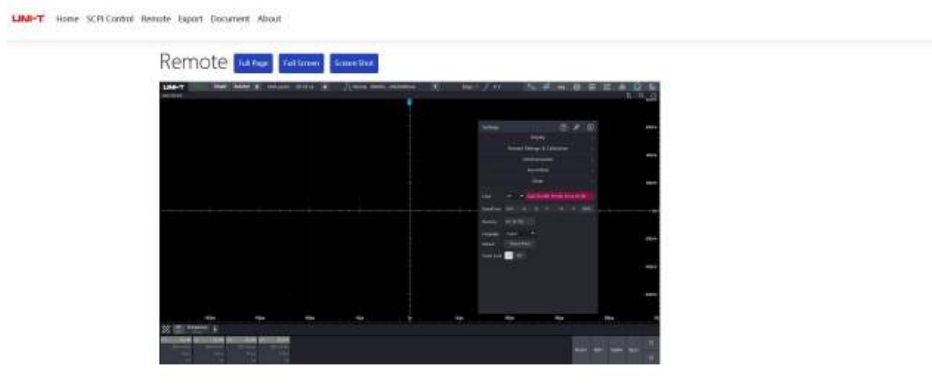

Remote Control Page

SCPI control

The oscilloscope can be controlled by sending SCPI (Standard Commands for Programmable Instruments). For details of SCPI programming commands, please refer to MSO8000HD Series Mixed Signal Oscilloscopes-Programming Manual.

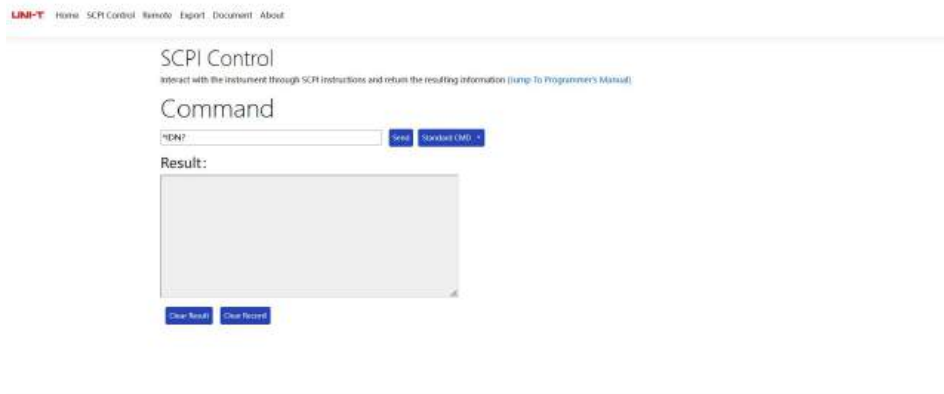

Export File

The waveform file can be exported in various formats on the webpage. The steps are as follows.

- (1) Select channel: C1~C4
- (2) Select format: The waveform file of Binary (.bin), Text (.txt), Matlab (.mat), Excel (.xlsx), CSV (.csv), TSV (.tsv)
- (3) Name the export file

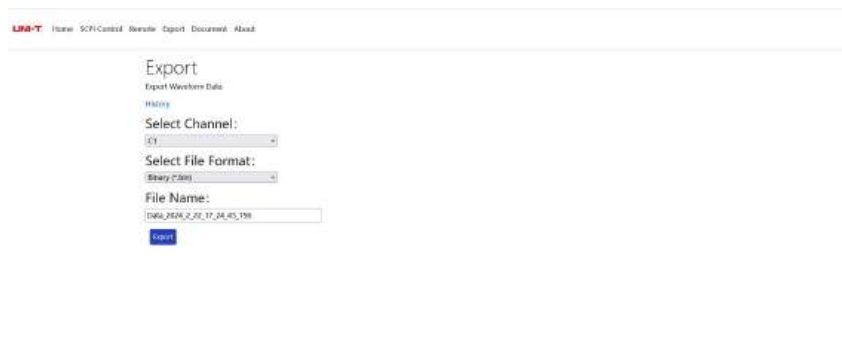

File

MSO8000HD series mixed signal oscilloscopes-programming manual and user's manual are embedded in the WebServer. The user can click the corresponding manuals to view the instrument operation guide.



Cellphone Access

It is required that the cell phone and the oscilloscope are under the same LAN (usually under the same WLAN band). The oscilloscope can view the local IP through the setting menu, and then the browser can access the oscilloscope by accessing the **IP: 80** port.

The functions of cell phone and computer are the same, only the layout is different.



Web Server Home Page



Remote Control

26. Troubleshooting

This section describes a list of faults and troubleshooting methods that may occur during the use of the oscilloscope. When you encounter these faults, please follow the corresponding steps to deal with them, if the problem cannot be fixed, please contact UNI-T, and provide the equipment information of your machine.

- (1) If the oscilloscope remains black screen without any display when press the power soft key.
 - ① Check if the power plug is properly connected and the power supply is normal.
 - ② Check if the power switch is turned on. If the power switch is turned on, the power soft key on the front panel should be orange. When the power soft key is enabled, the power soft key should be blue and the oscilloscope will make active sound. If there has sound and the screen is display, which indicates the oscilloscope is normal operating.
 - ③ If the product still does not work properly, contact the UNI-T Service Center for assistance.
- (2) After signal acquisition, the waveform of the signal does not appear on the screen.
 - ① Check whether probe and DUT are connected properly.
 - ② Check whether the signal connecting line is connect to analog channel.
 - ③ Check whether the analog input port of the input signal is the same as the open oscilloscope channel.
 - ④ Connect the probe-end to the probe compensation signal clip on the front panel of the oscilloscope to check if the probe is normal.
 - ⑤ Check whether DUT is generating a signal (the channel generating the signal can be connected to the problematic channel to determine the problem).
 - ⑥ Press the Autoset key to run automatic setting, to enable the oscilloscope to restart signal acquisition.
- (3) The measured voltage amplitude value is 10 times larger or 10 times smaller than the actual value.

Check whether the channel probe attenuation coefficient settings are consistent with the used probe attenuation rate.
- (4) There is a waveform display but not stable.
 - ① Check the trigger settings in trigger menu whether is consistent with the actual signal input channel.
 - ② Check the trigger type: general signals should use “Edge” trigger.

- ③ Try to change trigger coupling to HF rejection or LF rejection, to filter out the high-frequency or low-frequency noise that interfere the trigger.

(5) Touch function cannot be used.

- ① Check if the touch function is active. If this function is not enabled, press the Touch Lock key on the front panel to turn on.
- ② Check whether the oscilloscope is close to a strong magnetic field. If it is, move away from the field, to eliminate the effects of the magnetic field.
- ③ Check whether the screen and your fingers with oil. If there is, clean your fingers and the screen.
- ④ If the product still does not work properly, contact the UNI-T Service Center for assistance.

(6) Waveform refresh is very slow.

- ① Check whether the acquisition method is average and the average times are large.
- ② If you want to speed up the refresh speed, you can reduce the average time or choose other acquisition methods.

27. Appendix

27.1 Appendix A Accessory and Option

Product Model	
MSO8804HD	Bandwidth of 8GHz, the maximum 20GSa/s (half channel: 10GSa/s; four-channel: 10GSa/s); 4-channel oscilloscope
MSO8504HD	Bandwidth of 5GHz, the maximum 20GSa/s (half channel: 10GSa/s; four-channel: 10GSa/s); 4-channel oscilloscope
Standard accessory	
UT-D30	USB 3.0 cable x1
UT-L45	Passive high resistance probe 500MHz x 4 set
UT-KJG12	2 precision SMA adapters BNC to SMA (50Ω)
UT-JLC12	2 precision SMA cables at 12GHz, 1m
--	Protective cover front panel x1
--	National standard power cable x1
--	Calibration certificate
Standard software	
RS-232/422/485/UART	Embedded serial bus triggering and analysis (RS-232/422/485/UART)
SPI	Embedded serial bus triggering and analysis (SPI)
I2C	Embedded serial bus triggering and analysis (I2C)
CAN	Trigger and Analysis of Automotive Serial Bus (CAN)
LIN	Trigger and Analysis of Automotive Serial Bus (LIN)
Extreme Template Testing	Extreme testing, standard template testing
Spectrum analyzer	Enhanced FFT
Digital Voltmeter	4 bit, DC、AC RMS、DC+AC RMS
frequency meter	8 bit

Trigger software	Edge, pulse width, slope, video, code pattern, timeout, underestimation, establish/hold, delay, duration, N-edge, region trigger
WebServer	SCPI remote control, remote viewing and control, exporting waveform files, online browsing of manuals
Advanced analytics	Statistical histograms, trend charts, tracking, and regional histograms

Options - Upgrade Storage Depth

MSO8000HD-MD2G	Expand the maximum storage depth of the oscilloscope to 1Gpts/CH (full channel) and 2Gpts/CH (half channel)
----------------	---

Option - Upgrade 16 Channel Logic Analyzer

MSO8000HD-LA	16-channel logic analysis and logic probe (optional)
--------------	--

Options - Function/Arbitrary Waveform Generator

MSO8000HD-AWG	Dual-channel 60MHz arbitrary waveform generator (optional)
---------------	--

Options - Advanced jitter analysis and eye diagram

MSO8000HD-JITTER	Advanced jitter and eye-diagram analysis (optional)
------------------	---

Options - Advanced Power Analysis

MSO8000HD-PWR	Advanced power analysis (optional)
---------------	------------------------------------

Options - Protocol Trigger and Analysis

MSO8000HD-CANFD	Automobile serial bus trigger and analysis (CAN-FD)
MSO8000HD-FLEX	Automobile serial bus trigger and analysis (FlexRay)
MSO8000HD-SENT	Automobile sensor trigger and analysis (SENT)
MSO8000HD-AUDIO	Audio serial bus trigger and analysis (I ² S, LJ, RJ, TDM)
MSO8000HD-AERO	Aerospace serial bus trigger and analysis (MIL-STD-1553, ARINC 429)
MSO8000HD-SMBUS	Embedded serial bus trigger and analysis options (SMBus)
MSO8000HD-SPMI	Power Management Serial Bus Trigger and Analysis Options (SPMI)

MSO8000HD-I3C	MIPI-I3C bus trigger and analysis options (I3C)
MSO8000HD-PSI5	Automotive Serial Bus Analysis Options (PSI5)
MSO8000HD-USB2	USB bus trigger and analysis options (USB2.0)
MSO8000HD-PCIe2	PCIe bus trigger and analysis options (PCIe1.0, 2.0)
MSO8000HD-NET	Ethernet Bus Analysis Options (10BASE-T, 100BASE-TX)
MSO8000HD-NRZ	NRZ signal analysis option (NRZ)
MSO8000HD-MANCH	Manchester Signal Analysis Options (Manchester)
MSO8000HD-8B10B	8b/10b signal analysis option (8B/10B)
Options - Advanced Filter Designer	
MSO8000HD-FILTER	Advanced Filter Designer Options
Option - Matlab Embedded Programming	
MSO8000HD-MAT	Matlab embedded programming option, allowing users to create Matlab code to customize mathematical functions
Options - Consistency Analysis	
MSO8000HD-CTS100	100BASE Tx Ethernet Consistency Analysis Options
MSO8000HD-CTSUSB20	USB 2.0 Consistency Analysis Options
Upgrade Package	
MSO8000HD-BND	Upgrade package (including: advanced jitter analysis and eye diagram, protocol triggering and analysis)
Probe	
UT-PA2000	Active single ended probe (2GHz; 10X)
UT-PA1000	Active single ended probe (1GHz; 10X)
UT-PD2500	Active differential probe (2.5GHz; 10X)
UT-PD1500	Active differential probe (1.5GHz; 10X)
UT-P07A	Passive high resistance probe (1X: 8MHz; 10X: 500MHz)
UT-P20	Passive high voltage probe (100MHz; probe coefficient 100:1; 1.5kVrms)

UT-V23	Passive high voltage probe (100 MHz; 2kVpp)
UT-P21	Passive high voltage probe (50MHz; maximum of operating voltage DC 15kVrms)
UT-P40	Current probe (100kHz; 0.4A ~ 60A)
UT-P41	Current probe (100kHz; 0.4A ~ 100A)
UT-P42	Current probe (150kHz; 0.4A ~ 200A)
UT-P43	Current probe (25MHz; maximum of measuring current 20A)
UT-P44	Current probe (50MHz; maximum of measuring current 40A)
UT-P4030D	Current probe (100MHz; maximum of measuring current 30A)
UT-P4150	Current probe (12MHz; maximum of measuring current 150A)
UT-P4500	Current probe (5MHz; maximum of measuring current 500A)
UT-4100A	Current probe (600kHz; maximum of measuring current 100A)
UT-4100B	Current probe (2MHz; maximum of measuring current 100A)
UT-P30	High voltage differential probe (100MHz; ± 800 Vpp)
UT-P31	High voltage differential probe (100MHz; ± 1.5 kVpp)
UT-P32	High voltage differential probe (50MHz; ± 3 kVpp)
UT-P33	High voltage differential probe (120MHz; ± 14 kVpp)
UT-P35	High voltage differential probe (50MHz; 1.3kV)
UT-P36	High voltage differential probe (50MHz; 5.6kV)
UT-M15	16-channel logic analyzer probe

Notes: Please order all hosts, accessories and options from your local UNI-T distributor.

27.2 Appendix B Maintenance and Cleaning

(1) General Maintenance

Keep the instrument away from the direct sunlight.

Caution: Keep sprays, liquids and solvents away from the instrument or probe to avoid damaging the instrument or probe.

(2) Cleaning

Check the instrument frequently according to the operating condition. Follow these steps to clean the external surface of the instrument.

Please use a soft cloth to wipe the dust outside the instrument.

When cleaning the LCD screen, please pay attention and protect the transparent LCD screen.

When cleaning the dust screen, use a screwdriver to remove the screws of the dust cover and then remove the dust screen. After cleaning, install the dust screen in sequence.

Please disconnect the power supply, then wipe the instrument with a damp but not dripping soft cloth. Do not use any abrasive chemical cleaning agent on the instrument or probes.

Warning: Please confirm that the instrument is completely dry before use, to avoid electrical shorts or even personal injury caused by moisture.

27.3 Appendix C Warranty Overview

UNI-T (UNI-TREND TECHNOLOGY (CHINA) CO., LTD.) ensures the production and sale of products, from authorized dealer's delivery date of three years, without any defects in materials and workmanship. If the product is proven to be defective within this period, UNI-T will repair or replace the product in accordance with the detailed provisions of the warranty.

To arrange for repair or acquire warranty form, please contact the nearest UNI-T sales and repair department.

In addition to permit provided by this summary or other applicable insurance guarantee, UNI-T does not provide any other explicit or implied guarantee, including but not limited to the product trading and special purpose for any implied warranties. In any case, UNI-T does not bear any responsibility for indirect, special, or consequential loss.

27.4 Appendix D Contact Us

If the use of this product has caused any inconvenience, if you in mainland China you can contact UNI-T company directly.

Service support: 8am to 5.30pm (UTC+8), Monday to Friday or via email. Our email address is infosh@uni-trend.com.cn

For product support outside mainland China, please contact your local UNI-T distributor or sales center. Many UNI-T products have the option of extending the warranty and calibration period, please contact your local UNI-T dealer or sales center.

To obtain the address list of our service centers, please visit our website at URL: <http://www.uni-trend.com>

Options ordering and installation

1. **Purchase options:** Based on your requirements, please purchase the specified function options from Uni-t Sales Personnel and provide the serial number of the instrument that needs the option installed.
2. **Receive certificate:** You will receive the license certificate based on the address provided in the order.
3. **Register and obtain license:** Visit the Uni-t official website license activation session for registration. Use the license key and instrument serial number provided in the certificate to obtain the option license code and license file.
4. **Install the option:** Download the option license file to the root directory of a USB storage device, and connect the USB storage device to the instrument. Once the USB storage device is recognized, the Option Install menu will be activated. Press this menu key to begin installing the option.

Limited Warranty and Liability

UNI-T guarantees that the Instrument product is free from any defect in material and workmanship within three years from the purchase date. This warranty does not apply to damages caused by accident, negligence, misuse, modification, contamination or improper handling. If you need warranty service within the warranty period, please contact your seller directly. UNI-T will not be responsible for any special, indirect, incidental or subsequent damage or loss caused by using this device. For the probes and accessories, the warranty period is one year. Visit instrument.uni-trend.com for full warranty information.

Learn more at: www.uni-trend.com



Register your product to confirm your ownership. You will also get product notifications, update alerts, exclusive offers and all the latest information you need to know.

UNI-T® is the licensed trademark of UNI-TREND TECHNOLOGY CO., Ltd. The product information in this document subject to update without notice. For more information on UNI-T Test & Measure Instrument products, applications or service, please contact UNI-T instrument for support, the support center is available on www.uni-trend.com ->instruments.uni-trend.com

<https://instruments.uni-trend.com/ContactForm/>

Headquarter

Addresses: No6, Gong Ye Bei
1st Road. Songshan Lake
National High-Tech Industrial
Development Zone, Dongguan
City, Guangdong Province,
China
Tel: (86-769) 8572 3888

Europe

UNI-TREND TECHNOLOGY EU
GmbH
Addresses: Affinger Str. 12
86167 Augsburg Germany
Tel: +49 (0)821 8879980

North America

Uni-Trend Technology US INC.
Addresses: 3171 Mercer Ave
STE 104, Bellingham, WA
98225
Tel: +1-888-668-8648