



POWER QUALITY. SOLVED.

A STEEL PARTNERS COMPANY

# Matrix<sup>®</sup> E-Series

## 380V – 480V

### TECHNICAL REFERENCE MANUAL



**WARNING**

High Voltage! Only a qualified electrician can carry out the electrical installation of this filter.

#### Quick Reference

1	Performance Data	Pages 5 - 10
2	Selection Guide	Pages 11 - 14
3	Installation Guide	Pages 15 - 21
4	Start-up/Troubleshooting	Pages 22 - 25

**This page intentionally left blank**

## TABLE OF CONTENTS

<b>1. SAFETY</b> .....	<b>1</b>
WARNINGS AND CAUTIONS.....	1
PRODUCT SAFETY LABELING.....	1
GENERAL SAFETY INSTRUCTIONS.....	2
<b>2. GENERAL INFORMATION</b> .....	<b>3</b>
RECEIPT & REPAIR STATEMENT .....	3
STANDARDS AND AGENCY APPROVALS.....	4
WARRANTY.....	4
<b>3. MATRIX E-SERIES PERFORMANCE DATA</b> .....	<b>5</b>
PERFORMANCE SPECIFICATIONS .....	5
FILTER EFFICIENCY, WATT LOSS, AND CAPACITOR CURRENT.....	6
FILTER EFFICIENCY, WATT LOSS, AND CAPACITOR CURRENT.....	7
TYPICAL HARMONIC SPECTRUM .....	8
MATRIX E-SERIES % LOAD VS POWER FACTOR .....	8
TYPICAL PERFORMANCE WITH UNBALANCED LINE VOLTAGE.....	9
ALTITUDE DERATING.....	9
VOLTAGE DISTORTION DERATING.....	10
<b>4. HOW TO SELECT</b> .....	<b>11</b>
SELECTION GUIDE .....	11
MODEL NUMBER CODE SYSTEM:.....	12
MATRIX E-SERIES 380V – 415V SELECTION TABLES .....	13
MATRIX E-SERIES 480V SELECTION TABLES .....	14
<b>5. HOW TO INSTALL</b> .....	<b>15</b>
INSTALLATION CHECKLIST .....	15
GROUNDING .....	16
POWER WIRING CONNECTION .....	17
MATRIX E-SERIES SCHEMATIC DIAGRAM .....	18
INTERCONNECTION DIAGRAM .....	19
MATRIX E-SERIES 380V – 415V TORQUE RATINGS .....	20
MATRIX E-SERIES 480V TORQUE RATINGS .....	21
<b>6. START-UP</b> .....	<b>22</b>
SAFETY PRECAUTIONS.....	22
<b>7. TROUBLESHOOTING</b> .....	<b>23</b>
HARMONIC FILTER FIELD CHECKS .....	24

## List of Figures

Figure 3-1: Typical Harmonic Spectrum with and without Matrix E-SERIES .....	8
Figure 3-2: Power Factor .....	8
Figure 3-3: Altitude Derating Curve .....	9
Figure 3-4: Voltage Distortion Derating Curve .....	10
Figure 5-1: Basic Schematic Diagram .....	18
Figure 5-2: Open Panel Interconnection .....	19



## List of Tables

Table 3-1: Performance Specifications .....	5
Table 3-2: Filter Efficiency, Watt Loss, Capacitor Current .....	6
Table 3-3: Filter Efficiency, Watt Loss, Capacitor Current .....	7
Table 3-4: Typical Performance with Unbalanced Line Voltage .....	9
Table 4-1: Matrix E-Series 380V – 415V Open Panel .....	13
Table 4-2: Matrix E-Series 480V Open Panel .....	14
Table 5-1: Overtemperature Switch .....	16
Table 5-2: Torque Ratings 380V – 415V .....	20
Table 5-3: Torque Ratings 480V .....	21
Table 7-1: Troubleshooting Guide .....	25

# 1. SAFETY





## Warnings and Cautions

The following symbols are used in this manual.



 <b>WARNING</b>	High Voltage Warning: warns of situations that dangerously high voltage is involved. Failure to use proper precautions may lead to serious injury or death.
 <b>WARNING</b>	General Warning: warns of situations that can result in serious injury or death if proper precautions are not used.
 <b>Caution</b>	General Caution: identifies situations that could lead to malfunction or possible equipment damage.

## Product Safety Labeling

The following labels are placed on the Matrix E-Series product:

	Label notes to install to refer to instruction manual first before installing.
	High Voltage: surfaces on product can have high voltage which can cause injury.
	Wait five minutes for capacitors to discharge. Verify safe voltage level before servicing.
	Connect Thermal Switch: connecting the thermal switch can reduce risk of damage.

## General Safety Instructions

 <b>WARNING</b>	<p><b>High Voltage! Only a qualified electrician can carry out the electrical installation of this filter.</b></p>
	<p>High voltage is used in the operation of this filter. Use Extreme caution to avoid contact with high voltage when operating, installing or repairing this filter. <b>Injury or death may result if safety precautions are not observed.</b></p>
 <b>WARNING</b>	<p>The opening of the branch circuit protective device may be an indication that a fault current has been interrupted. To reduce the risk of fire or electrical shock, current-carrying parts and other components of the filter should be examined and replaced if damaged.</p>
	<p>An upstream disconnect/protection device must be used as required by the National Electrical Code (NEC) or governing authority.</p>
	<p>Even if the upstream disconnect/protection device is open, the drive downstream of the filter may feedback high voltage to the filter. The drive safety instructions must be followed. <b>Injury or death may result if safety precautions are not observed.</b></p>
	<p>The filter must be grounded with a grounding conductor connected to all grounding terminals.</p>
	<p>Only spare parts obtained from MTE Corporation or an authorized MTE distributor can be used.</p>
	<p>After removing power, allow at least five minutes to elapse and verify that the capacitors have discharged to a safe level before contacting internal components. Connect a DC voltmeter across the capacitor terminals and ensure that the voltage is at a safe level.</p>
 <b>Caution</b>	<p>Loose or improperly secured connections may damage or degrade filter performance. Visually inspect and secure all electrical connections before power is applied to the filter.</p>
	<p>Product should not be mounted on wood or any other combustible surface. Doing so could lead to fire or damage to the product.</p>
	<p>The user of this filter must assure that the input voltage and frequency is correct for the filter rating and that the voltage applied falls within the rated operating tolerance envelop specified for the filter. For severe power line applications where the power feed is likely to experience surges and transients that exceed the input voltage rating, it is recommended that a TVSS (Transient Voltage Surge Suppression) or SPD (Surge Protection Device) be deployed ahead of the filter to reduce the possibility of exceeding the filter rated voltage. Consult with TVSS or SPD manufacturer to determine the correct protection for your power line conditions.</p>
	<p>Filter must be mounted in the proper orientation per labeling.</p>

## 2. GENERAL INFORMATION

The purpose of this manual is to aid in the proper installation of the Matrix® E-Series.

For most current product information, please refer to our website:  
[www.mtecorp.com/products/harmonic-filters/matrix-e-series-harmonic-filter/](http://www.mtecorp.com/products/harmonic-filters/matrix-e-series-harmonic-filter/)

This manual is intended for use by personnel experienced in the operation and maintenance of drives. Because of the high voltages required by the filter, drive and the potential dangers presented by rotating machinery, it is essential that all personnel involved in the operation and maintenance of this filter know and practice the necessary safety precautions for this type of equipment. Personnel should read and understand the instructions contained in this manual before installing, operating or servicing the filter and drive to which it is connected.

### Receipt & Repair Statement

#### Upon Receipt of this Filter:

The Matrix E-Series Harmonic Filter has been subjected to demanding factory tests before shipment. Carefully inspect the shipping container for damage that may have occurred in transit. Then unpack the filter and carefully inspect for any signs of damage. Save the shipping container for future transport of the filter.

**In the event of damage, please contact and file a claim with the freight carrier involved immediately.**

If the equipment is not going to be put into service upon receipt, cover and store the filter in a clean, dry location. After storage, ensure that the equipment is dry, and that no condensation or dirt has accumulated on the internal components of the filter before applying power.

#### Repair/Exchange Procedure

MTE Corporation requires a Return Material Authorization Number and form before we can accept any filters that qualify for return or repair. If problems or questions arise during installation, setup, or operation of the filter, please contact MTE for assistance at:

Toll Free: 1-800-455-4MTE (1-800-455-4683)

International Tel: (+1)-262-253-8200

Fax: (+1)-262-253-8222

## Standards and Agency Approvals

<b>Standards</b>	CSA-C22.2 No 14-95 CE EN50178:1997 Support in the compliance of IEEE-519
<b>Agency Approvals</b>	UL and cUL listed to UL508 Type MAE CE Marked RoHS Compliant REACH Compliant

## Warranty

One year from the date of shipment. See <http://www.mtecorp.com/industry-leading-warranty/> for details.





### 3. MATRIX E-Series PERFORMANCE DATA

#### Performance Specifications

Table 3-1: Performance Specifications

Service Load Condition	Load: 6-pulse variable torque rectifier only
Input Voltage	380-415V +/- 10%; 50 + 0.75Hz. 3-phase 480V +/- 10%; 60 + 0.75Hz; 3-phase
Current Range	6A – 320A (1.1 KW – 150 KW; 3HP – 250HP)
<b>Maximum THID</b>	
With DC Link Choke or Reactor	8% @ full load; 12% @ 40% load
Without DC Link Choke or Reactor	12% @ full load; 17% @ 40% load
System Power Conditions at Rated Current	THVD: <2% Line Voltage Unbalance: <1%
Source Impedance	Maximum: 6% Minimum: 1.5%
Maximum output voltage at no load (RMS Peak)	+5%
Minimum output voltage at full load (RMS Peak)	-5%
Service Factor	1.00
<b>Ambient Temperature (Operating)</b>	
Open Panel Filters	-40 to +50 degrees C
Storage Temperature	-40 to +90 degrees C
Insertion Loss @ Full Load	<5%
Efficiency	>98%
Altitude without Derating	3,300 Feet above sea level.
Relative Humidity	0 to 95% non-condensing
Current Rating (Overload)	150% for 1-minute duration; once per hour
Over Voltage	Category II

**Fan Cooling:**

- For units 21 Amps and above: Proper cooling airflow must be provided at a minimum of 400 linear feet/min.

## Filter Efficiency, Watt Loss, and Capacitor Current Matrix E-Series 380-415V, 50Hz

**Table 3-2: Filter Efficiency, Watt Loss, Capacitor Current**

Maximum Output Amps RMS	Efficiency (%)	Typical Power Dissipation (Watts)	Typical Capacitor Current (Amps RMS)
6	98.5%	65	2.4
8	98.7%	74	3.2
11	98.8%	94	4.4
14	98.9%	106	5.6
21	98.7%	192	8.4
27	98.9%	212	10.8
34	99.1%	205	13.6
44	99.1%	270	17.6
52	99.2%	278	20.8
66	99.2%	359	26.4
83	99.3%	378	33.2
103	99.4%	397	41.2
128	99.5%	480	51.2
165	99.4%	668	66.0
208	99.5%	732	83.0
240	99.5%	768	94.0
320	99.6%	929	125.0

**NOTE:** Use the IEC AC-3 rating for the corresponding filter capacitor current when selecting a contactor.

## Filter Efficiency, Watt Loss, and Capacitor Current Matrix E-Series 480V, 60Hz

**Table 3-3: Filter Efficiency, Watt Loss, Capacitor Current**

Maximum Output Amps RMS	Efficiency (%)	Typical Power Dissipation (Watts)	Typical Capacitor Current (Amps RMS)
6	98.3%	70	2.2
8	98.4%	79	2.9
11	98.3%	101	4.0
14	98.5%	113	5.0
21	98.6%	205	7.6
27	98.5%	227	9.7
34	98.7%	219	12.2
44	98.8%	289	15.8
52	99.0%	297	18.7
66	99.0%	384	23.8
83	99.1%	404	29.9
103	99.1%	425	37.1
128	99.1%	513	46.1
165	99.2%	714	59.4
208	99.2%	783	74.7
240	99.3%	821	84.6
320	99.3%	994	112.5

**NOTE:** Use the IEC AC-3 rating for the corresponding filter capacitor current when selecting a contactor.

### Typical Harmonic Spectrum

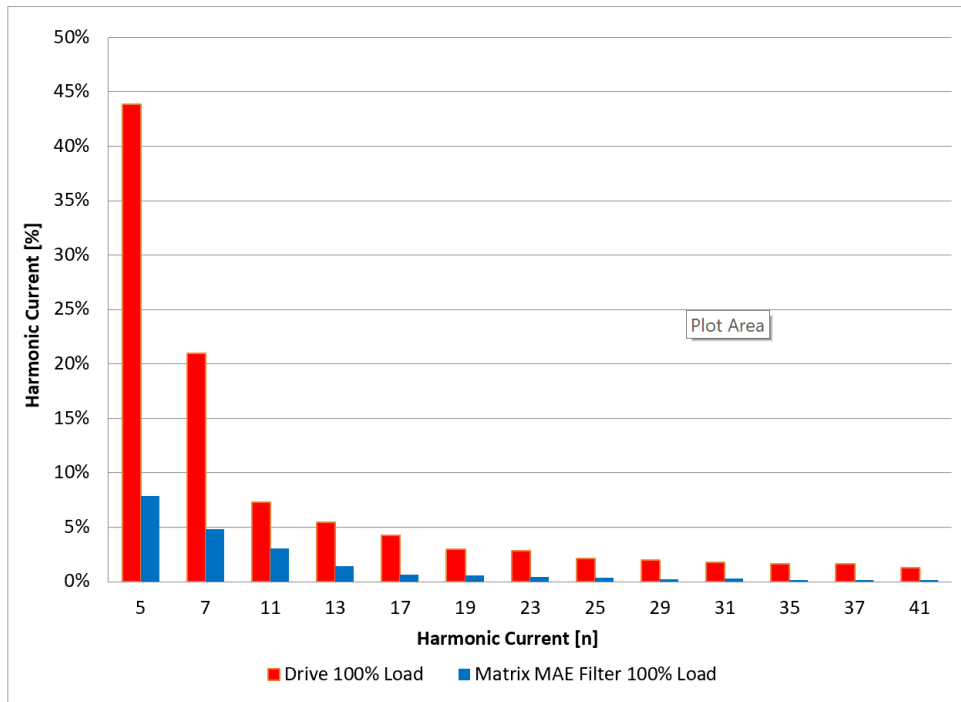

Figure 3-1: Typical Harmonic Spectrum with and without Matrix E-SERIES

### Matrix E-Series % Load vs Power Factor

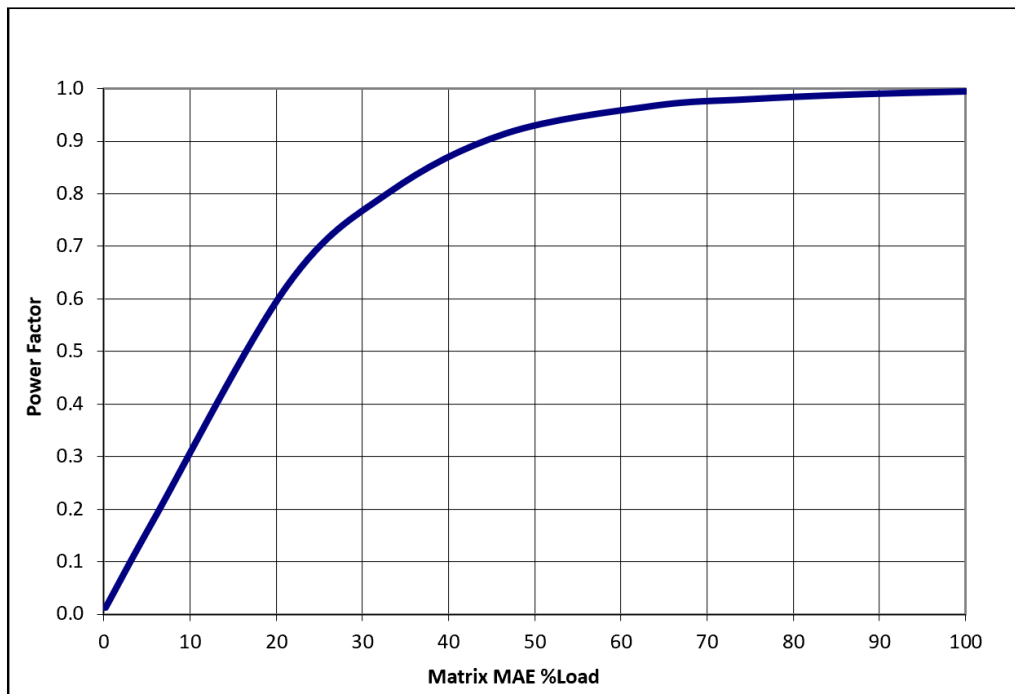

Figure 3-2: Power Factor

## Typical Performance with Unbalanced Line Voltage

**Table 3-4: Typical Performance with Unbalanced Line Voltage**  
**All Components at Nominal Values and Worse Case Service Conditions**

100% Load	
Nominal THID	11.39%
1% Unbalance	11.45%
2% Unbalance	11.50%
3% Unbalance	11.66%
30% Load	
Nominal THID	17.83%
1% Unbalance	17.88%
2% Unbalance	17.92%
3% Unbalance	17.94%

## Altitude Derating

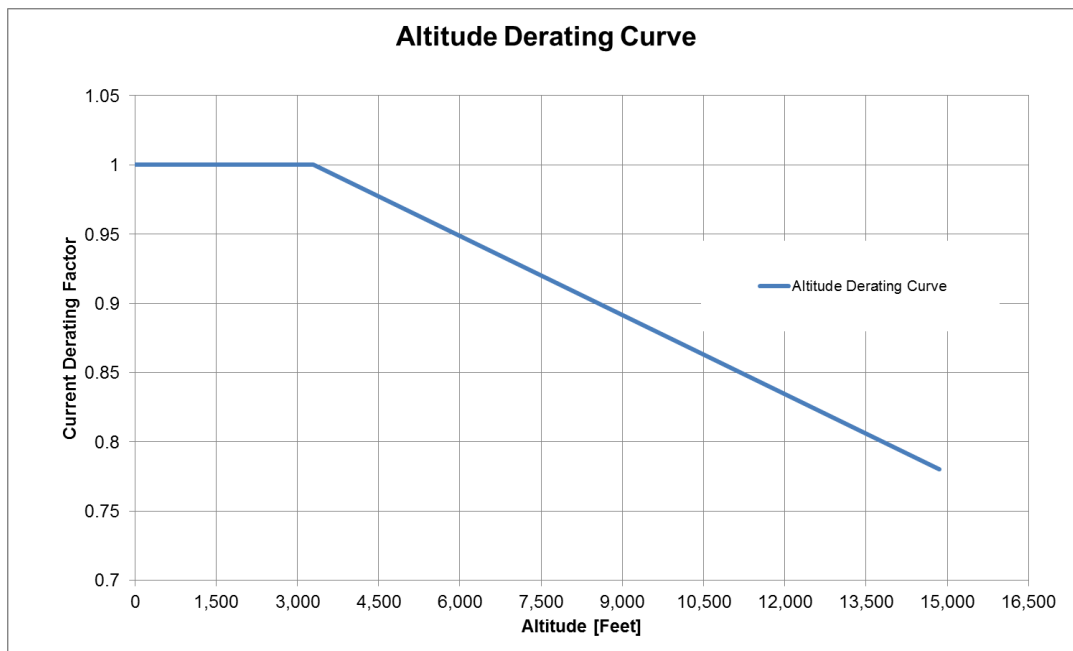

**Figure 3-3: Altitude Derating Curve**

## Voltage Distortion Derating

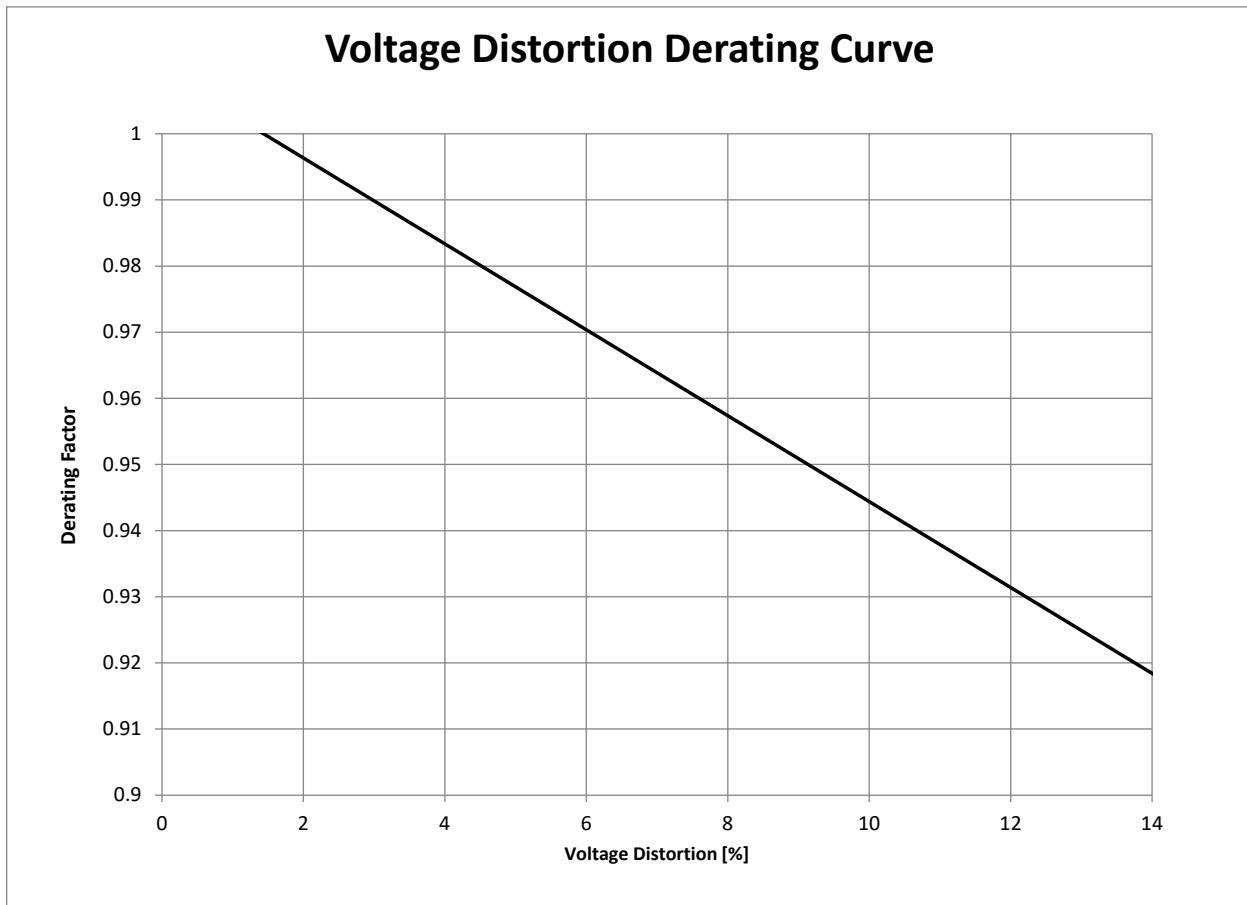

**Figure 3-4: Voltage Distortion Derating Curve**

**This plot assists in proper de-rating of a Matrix E-Series harmonic filter in environments with a preexisting voltage distortion. Example: In a system with 10% voltage distortion, a Matrix filter will need to be oversized by 5.5% to obtain the same performance as an appropriate filter in a 0% distortion environment.**

## 4. HOW TO SELECT

### Selection Guide

The Matrix E-Series harmonic filter is designed for harmonic mitigation of 6-pulse inverter drives supplying variable torque loads in a wide variety of applications. The suitability of this filter for a specific application must therefore be determined by the customer. In no event will MTE Corporation assume responsibility or liability for any direct or consequential damages resulting from the use or application of this filter, nor will MTE Corporation assume patent liability with respect to the use of information, circuits or equipment described in this instruction manual.

Matrix E-Series harmonic filters are available in Open Panel configurations.

For inverters feeding isolation transformers select a filter with a current rating equal to or greater than that of the transformer primary current.

**Please verify information below for proper selection:**

- Line Voltage and Frequency:** Input voltage 380V – 415V, 50Hz and 480V, 60Hz. See Table 3-1: Performance Specifications (p5) for specification.
- Current Rating:** 380V – 480V, 6-320 Amp
- Voltage Distortion:** See Figure 3-4: Voltage Distortion Derating Curve (p10) for voltage distortion derating curve.
- Temperature:** See Table 3-1: Performance Specifications (p5) for specification.
- Altitude:** 3,300 feet above sea level without derating. See Figure 3-3: Altitude Derating Curve (p9) for derating curve.

**Model Number Code System:**

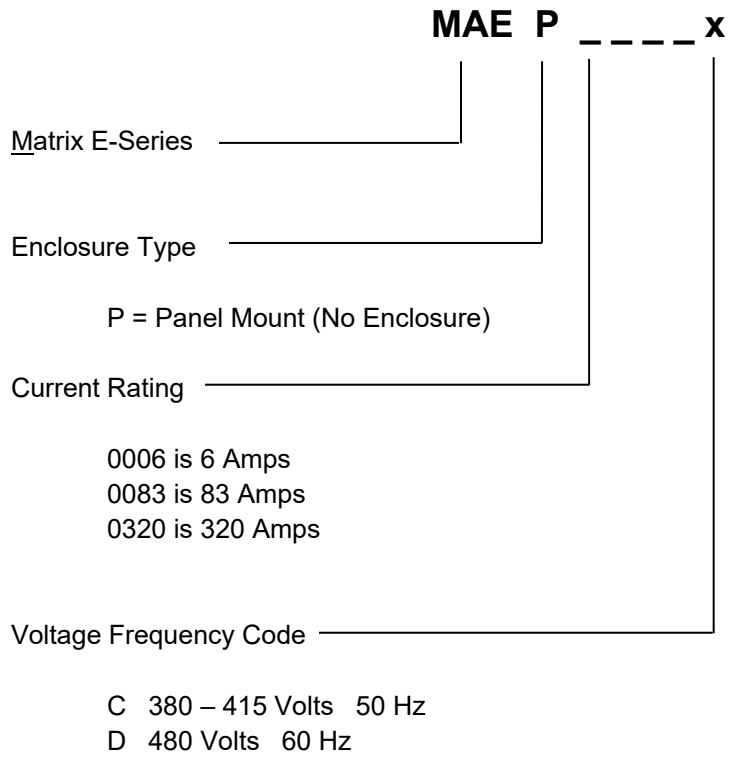



## Matrix E-Series 380V – 415V Selection Tables

Table 4-1: Matrix E-Series 380V – 415V Open Panel

Filter Amps Rating	Part Number	App. Wt. (lbs.)	App. Wt. (kg)	Reactor Dimensions (H x W x D)		Capacitor(s) Dimensions (H x W)	
				(in.)	(mm)	(in.)	(mm)
6	<a href="#">MAEP0006C</a>	13	6	8.2 x 6.9 x 3.5	208 x 175 x 89	7.5 x 3.0	191 x 76
8	<a href="#">MAEP0008C</a>	18	8	9.8 x 6.9 x 3.5	249 x 175 x 89	7.5 x 3.9	191 x 99
11	<a href="#">MAEP0011C</a>	27	12	9.8 x 6.9 x 4.1	249 x 175 x 104	7.5 x 3.9	191 x 99
14	<a href="#">MAEP0014C</a>	27	12	9.8 x 6.9 x 4.1	249 x 175 x 104	7.5 x 3.9	191 x 99
21	<a href="#">MAEP0021C</a>	30	14	12.0 x 7.1 x 5.4	305 x 180 x 137	7.5 x 4.6	191 x 117
27	<a href="#">MAEP0027C</a>	36	16	12.0 x 7.1 x 5.6	305 x 180 x 142	9.1 x 4.6	231 x 117
34	<a href="#">MAEP0034C</a>	41	19	12.0 x 7.1 x 6.1	305 x 180 x 155	9.1 x 4.6	231 x 117
44	<a href="#">MAEP0044C</a>	43	20	12.0 x 7.1 x 6.1	305 x 180 x 155	10.6 x 4.6	269 x 117
52	<a href="#">MAEP0052C</a>	55	25	14.5 x 9.6 x 6.9	368 x 244 x 175	9.1 x 4.6 / 7.5 x 3.9	231 x 117 / 191 x 99
66	<a href="#">MAEP0066C</a>	60	27	14.6 x 9.6 x 6.7	371 x 244 x 170	10.6 x 4.6 / 9.1 x 4.6	269 x 117 / 231 x 117
83	<a href="#">MAEP0083C</a>	74	34	14.5 x 9.6 x 7.5	368 x 244 x 191	10.6 x 4.6 (2)	269 x 117 (2)
103	<a href="#">MAEP0103C</a>	86	39	14.6 x 9.6 x 8.3	371 x 244 x 211	10.6 x 4.6 (2)	269 x 117 (2)
128	<a href="#">MAEP0128C</a>	97	44	14.9 x 9.6 x 8.8	378 x 244 x 224	10.6 x 4.6 (2)	269 x 117 (2)
165	<a href="#">MAEP0165C</a>	119	54	16.9 x 11.0 x 9.0	429 x 279 x 229	10.6 x 4.6 (3)	269 x 117 (3)
208	<a href="#">MAEP0208C</a>	136	62	17.1 x 11.0 x 9.3	434 x 279 x 236	10.6 x 4.6 (3)	269 x 117 (3)
240	<a href="#">MAEP0240C</a>	166	75	16.8 x 11.0 x 10.5	427 x 279 x 267	7.5 x 3.0 (3) / 10.6 x 4.6	191 x 76 (3) / 269 x 117
320	<a href="#">MAEP0320C</a>	181	82	17.1 x 11.0 x 10.4	434 x 279 x 264	10.6 x 4.6 (4)	269 x 117 (4)

**NOTE:** Approximate weight of filter above includes weight of reactor and accompany capacitor(s).

**NOTE:** Reference drawings can be accessed by clicking on the part number.

## Matrix E-Series 480V Selection Tables

Table 4-2: Matrix E-Series 480V Open Panel



Filter Amps Rating	Part Number	App. Wt. (lbs.)	App. Wt. (kg)	Reactor Dimensions (H x W x D)		Capacitor(s) Dimensions (H x W)	
				(in.)	(mm)	(in.)	(mm)
6	<a href="#">MAEP0006D</a>	13	6	8.2 x 6.9 x 3.5	208 x 175 x 89	7.5 x 3.0	191 x 76
8	<a href="#">MAEP0008D</a>	17	8	9.8 x 6.9 x 3.5	249 x 175 x 89	7.5 x 3.0	191 x 76
11	<a href="#">MAEP0011D</a>	24	11	9.8 x 6.9 x 3.8	249 x 175 x 97	7.5 x 3.9	191 x 99
14	<a href="#">MAEP0014D</a>	27	12	9.8 x 6.9 x 4.1	249 x 175 x 104	7.5 x 3.9	191 x 99
21	<a href="#">MAEP0021D</a>	29	13	12.0 x 7.1 x 5.4	305 x 180 x 137	7.5 x 3.9	191 x 99
27	<a href="#">MAEP0027D</a>	33	15	12.0 x 7.1 x 5.6	305 x 180 x 142	7.5 x 3.9	191 x 99
34	<a href="#">MAEP0034D</a>	40	18	12.0 x 7.1 x 6.1	305 x 180 x 155	7.5 x 3.9 / 7.5 x 3.0	191 x 99 / 191 x 76
44	<a href="#">MAEP0044D</a>	43	20	12.0 x 7.1 x 6.1	305 x 180 x 155	7.5 x 3.0 / 9.1 x 4.6	191 x 76 / 231 x 117
52	<a href="#">MAEP0052D</a>	53	24	14.5 x 9.6 x 6.9	368 x 244 x 175	9.1 x 4.6	231 x 117
66	<a href="#">MAEP0066D</a>	56	25	14.6 x 9.6 x 6.7	371 x 244 x 170	7.5 x 3.0 / 10.6 x 4.6	191 x 76 / 269 x 117
83	<a href="#">MAEP0083D</a>	73	33	14.5 x 9.6 x 7.5	368 x 244 x 191	9.1 x 4.6 (2)	231 x 117 (2)
103	<a href="#">MAEP0103D</a>	82	37	14.6 x 9.6 x 8.3	371 x 244 x 211	10.6 x 4.6 / 7.5 x 3.9	269 x 117 / 191 x 99
128	<a href="#">MAEP0128D</a>	97	44	14.9 x 9.6 x 8.8	378 x 244 x 224	10.6 x 4.6 (2)	269 x 117 (2)
165	<a href="#">MAEP0165D</a>	115	52	16.9 x 11.0 x 9.0	429 x 279 x 229	7.5 x 3.0 (2) / 10.6 x 4.6	191 x 76 (2) / 269 x 117
208	<a href="#">MAEP0208D</a>	136	62	17.1 x 11.0 x 9.3	434 x 279 x 236	7.5 x 3.9 (2) / 10.6 x 4.6 (2)	191 x 99 (2) / 269 x 117 (2)
240	<a href="#">MAEP0240D</a>	160	73	16.8 x 11.0 x 10.5	427 x 279 x 267	7.5 x 3.0 (2) / 9.1 x 4.6 (2)	191 x 76 (2) / 231 x 117 (2)
320	<a href="#">MAEP0320D</a>	183	83	17.1 x 11.0 x 10.4	434 x 279 x 264	10.6 x 4.6 (4) / 7.5 x 3.0	269 x 117 (4) / 191 x 76

**NOTE:** Approximate weight of filter above includes weight of reactor and accompany capacitor(s).

**NOTE:** Reference drawings can be accessed by clicking on the part number.

## 5. HOW TO INSTALL

### Installation Checklist

 <b>WARNING</b>	<p>Prior to installation, please refer to all general warnings on pages 1 &amp; 2. Failure to practice this can result in bodily injury!</p> <p>Input and output wiring to the filter should be performed by authorized personnel in accordance with NEC and all local electrical codes and regulations.</p>
 <b>WARNING</b>	<p>The filter is designed for use with copper conductors with a minimum temperature rating of 75 degrees C.</p>
 <b>CAUTION</b>	<p><b><u>FAN COOLING</u></b>  <b>For units 21 Amps and above: Proper cooling airflow must be provided at a minimum of 400 linear feet/min.</b></p>

**Matrix E-Series filters are supplied in the following configuration(s):**

- Open Panel (Modular): Open panel units consist of a reactor and one or more capacitors. Additional wiring between the reactor and capacitor is required by the customer.

Open panel Matrix E-Series filters are designed for mounting within the customer’s enclosure. When determining the internal temperature rise and cooling requirements of the enclosure, include the power dissipation of the filter along with all the other components located in the enclosure. A general guideline is to allow a side clearance of four (4) inches and a vertical clearance of six (6) inches for proper heat dissipation and access with the enclosure.

**For units 21 Amps and above, proper cooling airflow must be provided at a minimum of 400 linear feet/min.**

Do not install in or near a corrosive environment.

Avoid locations where the filter would be subjected to excessive vibrations.

Locate the filter in the lowest temperature regions of the enclosure – generally toward the bottom and away from high temperature components.

Refer to Article 430 Table 430.91 of the National Electrical code for the selection of the appropriate enclosure Type Number for your application.

## Grounding

 <b>WARNING</b>	<p>The filter must always be grounded with a grounding conductor connected to ground terminals.</p>
-----------------------------------------------------------------------------------------------------	-----------------------------------------------------------------------------------------------------

**NOTE:** For cable shield grounding follow the drive manufacturer's recommendations.

### Grounding and Ground Fault Protection

Due to high leakage currents associated with variable frequency drives, ground fault protective devices do not necessarily operate correctly when placed ahead of a Matrix Filter feeding a drive. When using this type of device, its function should be tested in the actual installation.

### Overtemperature Interlock

An overtemperature interlock circuit should be used in conjunction with thermal switch to turn off the drive to prevent filter damage due to abnormal operating conditions. The temperature switch is normally closed and will open when an internal reactor temperature of 180°C is reached. See Table 5-1: Overtemperature Switch below for contact rating information and the drive user manual for interconnection information.

**Table 5-1: Overtemperature Switch**

<i>NC Switch</i> opens at 180 Deg. +/- 5 Deg. C		
<b>Current Amps</b>	<b>Voltage</b>	<b>Contact Load</b>
6	120 AC	Resistive Loads
3	120 AC	Inductive Loads
3	240 AC	Resistive Loads
2.5	240 AC	Inductive Loads
8	12 VDC	Resistive Loads
4	24 VDC	Resistive Loads

MTE highly recommends the use of the overtemperature switch to prevent damage to the filter in rare instances of overheating from abnormal operating conditions.

## Power Wiring Connection

 <b>WARNING</b>	Input and output power wiring to the filter should be performed by authorized personnel in accordance with the NEC and all local electrical codes and regulations. Cable lugs and mounting hardware are provided by the customer.
	Any extremely low or high resistance readings indicate miswiring and may result in damage to filter components if not corrected.

Verify that the power source to which the filter is to be connected is in agreement with the nameplate data on the filter. A fused disconnect switch or circuit breaker should be installed between the drive and its source of power in accordance with the requirements of the NEC and all local electrical codes and regulations. Refer to the drive user manual for selection of the correct fuse rating and class.

Refer to the drive user manual for instructions on interconnecting the drive and motor and the correct start-up procedures for the drive.

The filter is designed for use with copper conductors with a minimum temperature rating of 75 degrees C.

### Wiring Checks

Using Figure 5-1: Basic Schematic Diagram (p18) visually check the wired components to confirm, verify, and correct wiring. Then, with a multi meter, check phase to phase isolation using the 100 K ohm range. The multi meter will read the parallel equivalent of the bleeder resistors after the capacitors initially charge. All phase to phase resistance values should be the same.

#### Check for the Following Faults:

- Capacitor shorted
- Capacitor bus not connected
- Capacitor bus to chassis short
- Paralleling wiring errors

### Matrix E-Series Schematic Diagram

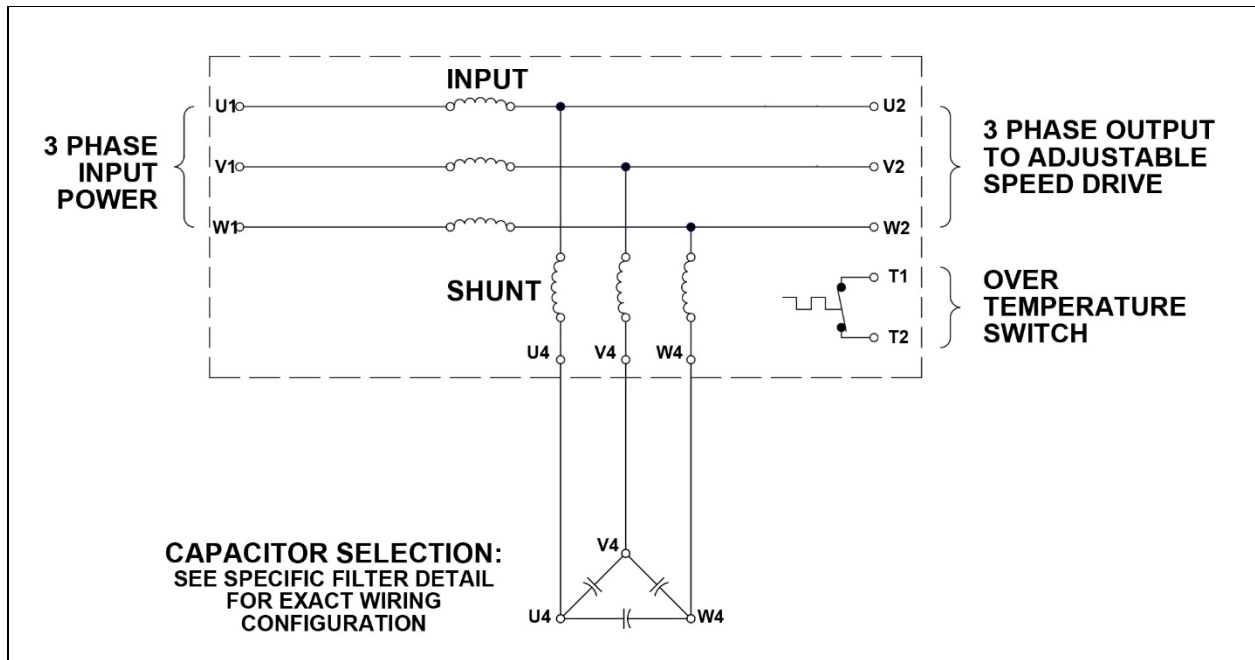

Figure 5-1: Basic Schematic Diagram

## Matrix E-Series Interconnection Diagram

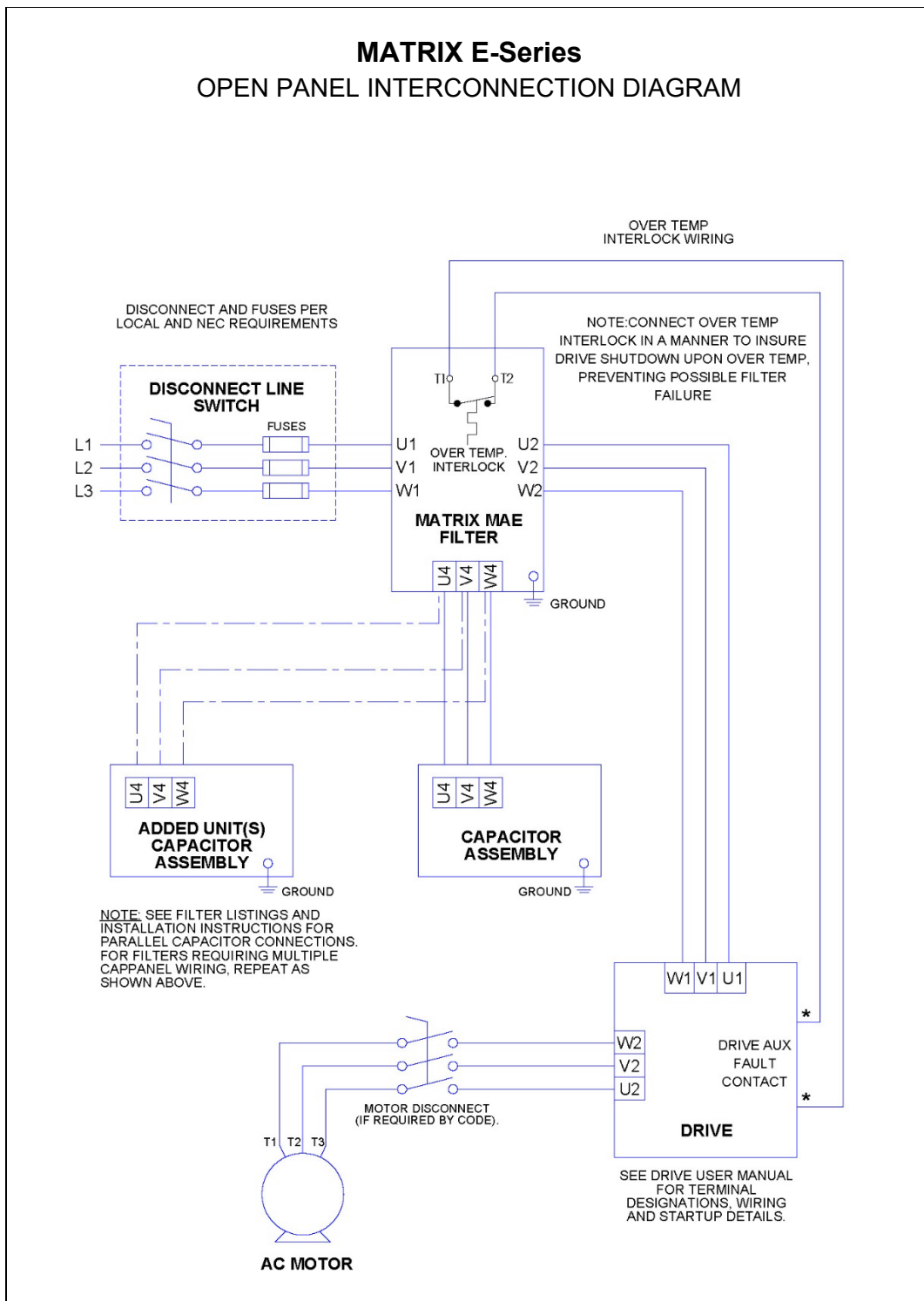

Figure 5-2: Open Panel Interconnection

## Matrix E-Series 380V – 415V Torque Ratings

Table 5-2: Torque Ratings 380V – 415V

Filter Rating (Amps)	Reactor Terminals			Capacitor Terminals U4-V4-W4		
	Input /Output Power U1-V1-W1 / U2-V2-W2		Interconnect Reactor U4-V4-W4	Capacitor Part Number	Minimum Interconnect Wire Gauge (AWG)	Terminal Torque (in-lbs.)
	Recommended Minimum Wire Gauge (AWG)	Terminal Torque (in-lbs.)	Terminal Torque (in-lbs.)			
6	14-6	16	16	CAP-349TP	14	23
8	14-6	16	16	CAP-365TP	14	23
11	14-6	16	16	CAP-366TP	14	23
14	14-6	16	16	CAP-342TP	14	23
21	14-6	16	16	CAP-344TP	14	23
27	14-6	16	16	CAP-345TP	14	23
34	14-6	16	16	CAP-346TP	12	23
44	14-6	16	16	CAP-347TP	12	23
52	Flat copper tab	N/A	16	CAP-346TP/ CAP-342TP	10	23
66	Flat copper tab	N/A	16	CAP-347TP/ CAP-345TP	10	23
83	Flat copper tab	N/A	16	CAP-347TP (2)	10	23
103	Flat copper tab	N/A	16	CAP-348TP (2)	10	23
128	Flat copper tab	N/A	N/A	CAP-359TP (2)	10	23
165	Flat copper tab	N/A	N/A	CAP-359TP (2) / CAP-347TP	10	23
208	Flat copper tab	N/A	N/A	CAP-360TP (2) / CAP-348TP	8	23
240	Flat copper tab	N/A	N/A	CAP-360TP (3) / CAP-340TP	4	23
320	Flat copper tab	N/A	N/A	CAP-360TP (4)	2	23

**Note:** To prevent flexing or bending of the coil windings attached to the flat copper terminal tabs on the Matrix E-Series reactor, use two wrenches to tighten customer provided cable mounting hardware.



## Matrix E-Series 480V Torque Ratings

**Table 5-3: Torque Ratings 480V**

Filter Rating (Amps)	Reactor Terminals			Capacitor Terminals U4-V4-W4		
	Input /Output Power U1-V1-W1 / U2-V2-W2		Interconnect Reactor U4-V4-W4	Capacitor Part Number	Minimum Interconnect Wire Gauge (AWG)	Terminal Torque (in-lbs.)
	Recommended Minimum Wire Gauge (AWG)	Terminal Torque (in-lbs.)	Terminal Torque (in-lbs.)			
6	14-6	16	16	CAP-339TP	14	23
8	14-6	16	16	CAP-349TP	14	23
11	14-6	16	16	CAP-365TP	14	23
14	14-6	16	16	CAP-341TP	14	23
21	14-6	16	16	CAP-342TP	14	23
27	14-6	16	16	CAP-343TP	14	23
34	14-6	16	16	CAP-349TP / CAP-343TP	12	23
44	14-6	16	16	CAP-339TP / CAP345TP	12	23
52	Flat copper tab	N/A	16	CAP-346TP	10	23
66	Flat copper tab	N/A	16	CAP-347TP/ CAP-339TP	10	23
83	Flat copper tab	N/A	16	CAP-345TP / CAP-346TP	10	23
103	Flat copper tab	N/A	16	CAP-348TP / CAP-343TP	10	23
128	Flat copper tab	N/A	N/A	CAP-347TP (2)	10	23
165	Flat copper tab	N/A	N/A	CAP-348TP (2) / CAP-340TP	10	23
208	Flat copper tab	N/A	N/A	CAP-348TP (2) / CAP-343TP (2)	8	23
240	Flat copper tab	N/A	N/A	CAP-338TP (2) / CAP-345TP / CAP-346TP	4	23
320	Flat copper tab	N/A	N/A	CAP-348TP (4) / CAP-340TP	2	23

**Note:** To prevent flexing or bending of the coil windings attached to the flat copper terminal tabs on the Matrix E-Series reactor, use two wrenches to tighten customer provided cable mounting hardware.

## 6. START-UP

### Safety Precautions

Before start-up, observe the following warnings and instructions:

 <b>WARNING</b>	<p>Internal components of the filter are at line potential when the filter is connected to the drive. This voltage is extremely dangerous and may cause death or severe injury if you come in contact with it.</p>
	<p>Use extreme caution to avoid contact with line voltage when checking for power. <b>INJURY OR DEATH MAY RESULT IF SAFETY PRECAUTIONS ARE NOT OBSERVED.</b></p>
	<p>Damage to equipment or serious injury may occur if the inverter start-up procedures are not observed.</p>

### Sequence of Operation

1. Read and follow safety precautions.
2. After installation, ensure that:
  - a. All filter ground terminals are connected to ground.
  - b. Power wiring to the utility, drive and motor is in accordance with the power wiring connection diagrams shown in installation instructions section.
3. Check that moisture has not condensed on the filter components. If moisture is present, do not proceed with start-up until the moisture has been removed.
4. Disconnect the filter output from the drive.
5. Connect the filter to the utility.
6. Confirm that line voltage is present at the input terminals (U1, V1, W1) of the filter.
7. Confirm that line voltage is present at the output terminals (U2, V2, W2) of the filter and that it is less than or equal to 1.05 times the input voltage.
8. Using a clamp on Amp meter, check input phase currents to verify they are within a 5% match to each other and approximately 30% of filter current rating.
9. Remove power and verify that **NO VOLTAGE** is present on the filter terminals.
10. Connect the filter output to the drive.
11. Refer to the drive user manual for the drive start-up procedure. Observe all safety instructions in the drive user manual.

## 7. TROUBLESHOOTING

 <b>WARNING</b>	<p>When properly installed, this equipment has been designed to provide maximum safety for operating personnel.</p> <p>However, hazardous voltages and elevated temperatures exist within the confines of the enclosure. Servicing should therefore be performed by qualified personnel only and in accordance with OSHA Regulations.</p>
	<p>High voltage is used in the operation of this filter. Use Extreme caution to avoid contact with high voltage when operating, installing or repairing this filter. <b>INJURY OR DEATH MAY RESULT IF SAFETY PRECAUTIONS ARE NOT OBSERVED.</b></p>

To aid in troubleshooting, a basic schematic diagram, an interconnection diagram and a troubleshooting guide that lists potential problems and solutions are included:

**Figure 5-1: Basic Schematic Diagram (p18)**

**Figure 5-2: Open Panel Interconnection (p19)**

**Table 7-1: Troubleshooting Guide (p25)**

## Harmonic Filter Field Checks

1. Disconnect all power and remove input power wiring from U1, V1, and W1 terminals.
2. Remove VFD drive power connections from filter terminals U2, V2, and W2 as well as any control wiring to the filter contactor or temperature switch. (For filters using control transformers: remove power fuses on top of transformer.)
3. Visually inspect filter terminals and wiring lugs for signs of heat and corrosion. **Contact factory if any wires appear to be missing or cut!**
4. Inspect the U4, V4, and W4 capacitor interconnect terminals and wiring.
5. Visually inspect all capacitors for signs of case deformation, bowing of the top, leaking oil or terminal damage. Note the CAP- # and date code of any damaged capacitors.
6. Using a multi meter set to read 100K ohms check:
  - a. Phase to phase U1-V1-W1-U1 (mechanically activate contactor if present) after reactor and caps charge reading should be about 40K (total equivalent breeder resistance value). Open circuit or very low readings indicate a problem.
  - b. Phase to chassis U1- case, V1-case, and W1-case; low readings indicate a ground fault problem.
7. Ensure the “disconnect” is safe then wire the utility power to U1, V1, and W1.
8. Apply power and verify that proper output voltage is present on U2, V2, and W2.
9. Using a clamp on amp meter read the filter input current:
  - a. Mechanically activate the contactor if the filter is equipped with one. Readings should be the same (+/- 5%) for all phase currents; **contact the factory if currents are out of tolerance!**
  - b. Open contactor readings will show zero current for all phases.
10. Disconnect filter power and wire the VFD to U2, V2, and W2 as well as any control wiring to the filter contactor or temperature switch. Replace any control transformer fuses. Follow the drive power start-up guidelines in the drive manufacturer’s user manual.

**Table 7-1: Troubleshooting Guide**

<b>PROBLEM: Line voltage is not present at the filter output terminals.</b>	
<b>Possible cause:</b>	Power to the filter is turned off.
<b>Solution:</b>	Turn power on.
<b>Possible cause:</b>	One or more external line fuses are blown.
<b>Solution:</b>	Verify the continuity of line fuses in all phases. Replace as necessary.
<b>PROBLEM: Full Load Harmonic current distortion exceeds 12% at full load.</b>	
<b>Possible cause:</b>	A capacitor has failed.
<b>Solution:</b>	Inspect the tops of all capacitors for bowing. Replace failed capacitors.
<b>Possible cause:</b>	Source impedance is less than 1.5%.
<b>Solution:</b>	Add a minimum 1.5% impedance line reactor to the filter input.
<b>Possible cause:</b>	Input source voltage harmonic distortion.
<b>Solution:</b>	Identify equipment causing harmonic voltage distortion and add filters as required or accept elevated THVD.
<b>PROBLEM: Filter output voltage is not within specification</b>	
<b>Possible cause:</b>	Filter input voltage is not within specification.
<b>Solution:</b>	Check the AC input line voltage and verify that it is within tolerance. Refer to the filter service conditions and performance specifications for tolerances.
<b>Possible cause:</b>	Source impedance is out of tolerance.
<b>Solution:</b>	Verify that the source impedance is within tolerance. Refer to the filter service conditions and performance specifications for tolerances.
<b>Possible cause:</b>	One or more Capacitors are damaged.
<b>Solution:</b>	Visually check capacitor top for distortion or doming. Check for shorts or open caps. Replace failed capacitors.
<b>Possible cause:</b>	Drive set up parameter does not allow for input filter
<b>Solution:</b>	Consult drive manufacturer to update setup to accommodate input filter.
<b>Possible cause:</b>	Input voltage subject to extreme transients such as switching between two voltage sources. Drive faults on over or under voltage.
<b>Solution:</b>	Source switching is not recommended without proper phase synchronizing or allowing reasonable time delay before transfer to new source.