

DIGITAL
PROJECTOR

MX661



Features

- Native XGA (1024 x 768) Resolution
- 3,000 ANSI Lumens, 13,000:1 Contrast Ratio
- Wireless Display by MX661 QPresenter App
- LAN Control; HDMI, Speaker 2W x 1
- USB Display & Reader
- PC-less Presentation through Office Viewer



Input and Output Terminals

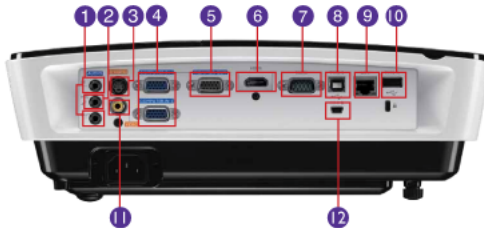

- | | |
|-----------------------------------|-----------------------------|
| 1 Audio In 1 & 2 (Mini Jack) | 7 RS232 (DB-9pin) |
| 2 Microphone | 8 USB (Type B) |
| 3 S-Video In (Mini DIN 4pin) | 9 LAN (RJ45) |
| 4 Computer In 1 & 2 (D-sub 15pin) | 10 USB (Type A) |
| 5 Monitor Out (D-sub 15pin) | 11 Composite Video In (RCA) |
| 6 HDMI | 12 USB (Type Mini B) |



Specifications

Projection System	DLP®	
Native Resolution	XGA(1024X768)	
Brightness	3,000 AL	
Contrast Ratio	13,000:1	
Display Color	1.07 Billion Colors	
Lens	F=2.51-2.69, f=21.95-24.18mm	
Aspect Ratio	Native 4:3 (5 aspect ratio selectable)	
Throw Ratio	1.97-2.17 (50"@2m)	
Image Size (Diagonal)	37"-300"	
Zoom Ratio	1.1:1	
Lamp Type	210W	
Lamp Life	3,500/5,000/6,500 hours (Normal/Eco/SmartEco)	
Keystone Adjustment	1D, Vertical +/- 40 degrees	
Projection Offset	130% ±5%	
Resolution Support	VGA(640 x 480) to UXGA(1600 x 1200)	
Horizontal Frequency	15-102 kHz	
Vertical Scan Rate	23-120 Hz	
Compatibility	HDTV Compatibility: 480i, 480p, 576i, 576p, 720p, 1080i, 1080p Video Compatibility: NTSC, PAL, SECAM	
Interface	Computer in (D-sub 15pin)	x 2 (Share with component)
	Monitor out (D-sub 15pin)	x 1
	HDMI	x 1
	Composite Video in (RCA)	x 1
	S-Video in (Mini DIN 4pin)	x 1
	Audio in (Mini Jack)	x 1
	Audio out (Mini Jack)	x 1
	Microphone in (Mini Jack)	x 1
	Speaker	2W x 1
	LAN (RJ45)	x 1 (LAN Control & LAN Display)
	USB (Type A)	x 1 (USB Reader & Wireless Display)
	USB (Type B)	x 1 (Download & Page up/down)
	USB (Type mini B)	x 1 (USB Display & Download)
	RS232 (DB-9pin)	x 1
	IR Receiver	x 1 (Front)
Dimensions (WxHxD)	12.8" x 4.9" x 9.1" (327 x 126 x 231 mm)	
Weight	5.7 lbs (2.6 kg)	
Power Supply	AC100 to 240 V, 50 to 60 Hz	
Power Consumption	285W(typical), Standby<0.5W	
Audible Noise	34/32 dBA (Normal/Economic mode)	
On-Screen Display Languages	Arabic/Bulgarian/ Croatian/ Czech/ Danish/ Dutch/ English/ Finnish/ French/ German/ Greek/ Hindi/ Hungarian/ Italian/ Indonesian/ Japanese/ Korean/ Norwegian/ Polish/ Portuguese/ Romanian/ Russian/ Simplified Chinese/Spanish/ Swedish/ Turkish/ Thai/ Traditional Chinese (28 Languages)	
Picture Modes	Dynamic/Presentation/sRGB/Cinema/User 1/User 2	
Accessories (Standard)	Remote Control w/ Battery, Power Cord, User Manual CD, Quick Start Guide, Warranty Card, VGA(D-sub 15pin) Cable, Carrying Bag	
Accessories (Optional)	Spare Lamp Kit	P/N: 5J.J8F05.001
	Ceiling Mount	P/N: 5J.J4N10.001
	3D Glasses	P/N: 5J.J7K25.001
	Wireless Dongle_WDRT8192	P/N: 5J.J3F28.A01
UPC Code	8400460-2700-1 / 9H.J8F77.33A	
Limited Warranty	3-Year Parts & Labor / 1-Year or 2000 hours of lamp life	

*Lamp life results will vary depending on environmental conditions and usage. Actual product's features and specifications are subject to change without notice.

MX661 06-10-13-BQus



BenQ America Corp.
15375 Barranca Parkway, Suite A-205, Irvine, CA 92618 ☎ Tel: (949) 255-9500 🌐 www.BenQ.us

BenQ is a registered trademark of BenQ Corp. DLP is a registered trademark of Texas Instruments. All rights reserved.
Product names, logos, brands, and other trademarks featured or referred to in this materials are the property of their respective trademark holders.
Specifications subject to change without notice.



MX661 Digital Projector

Distance Chart

The screen aspect ratio is 4:3 and the projected picture is 4:3

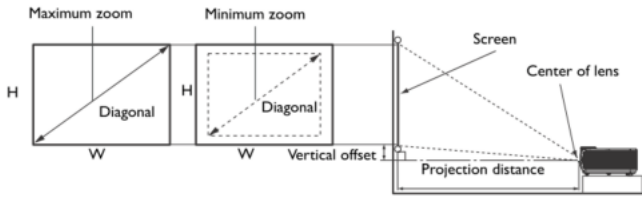

Screen Size				Distance from screen (inch)			Vertical offset (inch)
Diagonal	W	H	Min distance	Average	Max distance		
Inch	mm	(inch)	(inch)	(Max zoom)	Min zoom		
30	762	24	18	47.2	49.6	51.9	2.7
40	1016	32	24	62.9	66.1	69.2	3.5
50	1270	40	30	78.7	82.6	87.7	4.4
60	1524	48	36	94.4	99.2	103.9	5.3
80	2032	64	48	125.9	132.2	138.5	7.2
100	2540	80	60	157.4	165.3	173.2	9.0
120	3048	96	72	188.9	198.4	207.8	10.7
150	3810	120	90	236.2	248.0	259.8	13.5
200	5080	160	120	314.9	330.7	346.4	17.9
220	5588	176	132	346.4	363.7	381.1	19.8
250	6350	200	150	393.7	413.3	433.1	22.5
300	7320	240	180	472.4	496.1	519.6	27.0

Ceiling Mount Chart

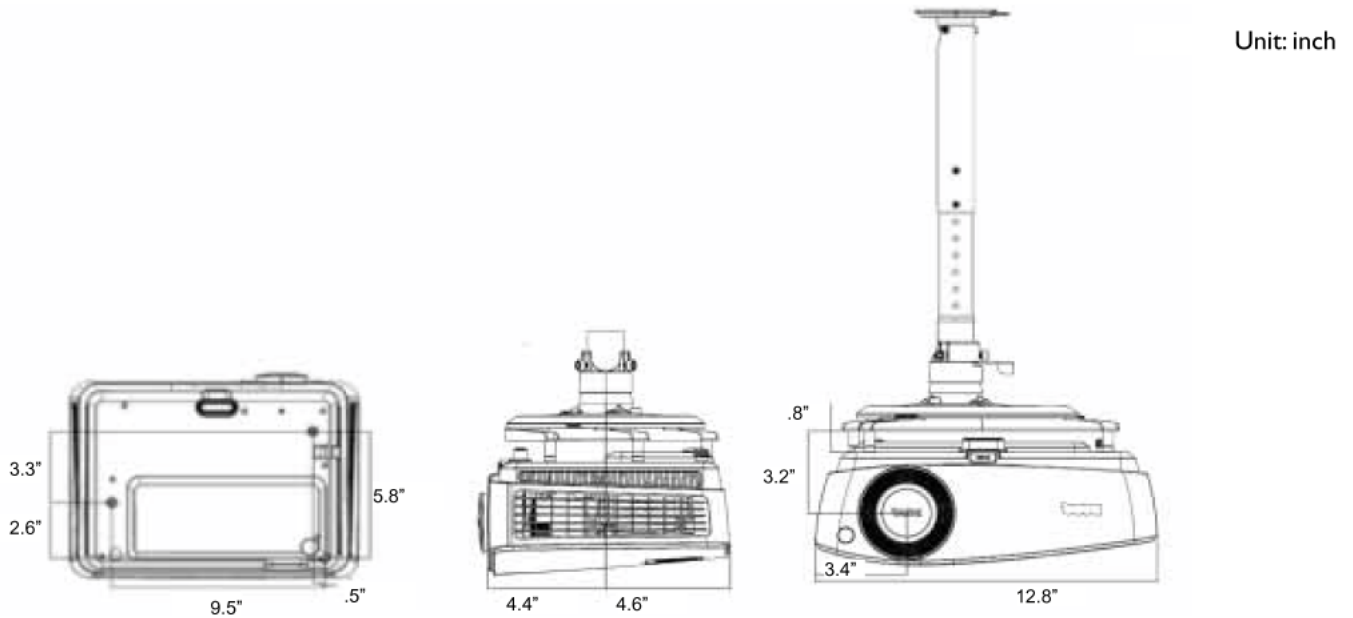

Dimensions



Touchboards

205 Westwood Ave, Long Branch, NJ 07740
 Phone: 866-94 BOARDS (26273) / (732)-222-1511
 Fax: (732)-222-7088 | E-mail: sales@touchboards.com

