



# ThermoVault Max

Extreme Temperature Thermal Barrier

Product User Guide



## Product Overview

The ThermoVault Max is an extreme, high temperature thermal barrier designed for use with the HiTemp140 series. This durable thermal barrier can withstand temperatures up to +400 °C in dry heat applications and +250 °C in wet applications when used with the TMAX Wet Seal Kit (optional accessory).

### Compatible Data Loggers

- » HiTemp140-M12
- » HiTemp140-FP
- » HiTemp140-PT

## Getting Started

### Dry Applications

The HiTemp140-FP, HiTemp140-PT HiTemp140-M12 can be used for dry applications up to +400 °C.



1. Unscrew the lid of the thermal barrier.

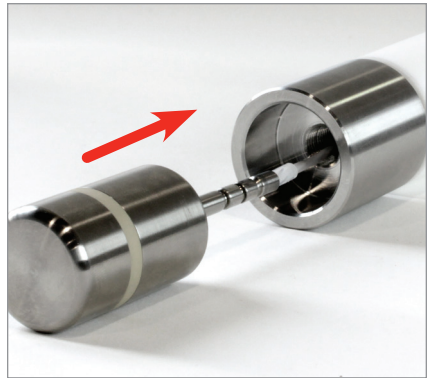

2. Feed the probe of the data logger through the bottom end of the lid.

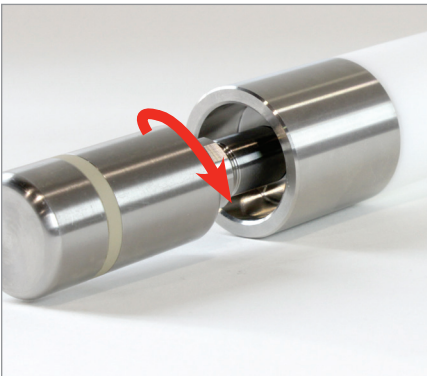

3. If using the HiTemp140-M12 data logger, screw the probe into the bottom end of the barrier lid.



4. Slide the data logger and lid back into the barrier body and screw the lid back on tightly.

## Wet Applications

For use in wet applications, the TMAX Wet Seal Kit (sold separately, optional accessory) should be used with the HiTemp140-FP, and HiTemp140-PT data logger. When used in wet applications the maximum operating environment cannot exceed 250 °C (482 °F).

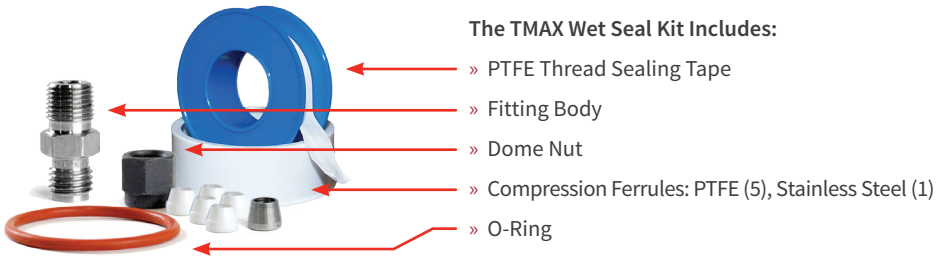

**Installing the O-Ring:** The O-Ring ensures a tight seal which prevents liquid from entering the inside of the barrier. O-Ring maintenance is a key factor when properly caring for the ThermoVault Max. Please refer to the application note “O-Rings 101: Protecting Your Data Logger,” found on the MadgeTech website, for information on how to prevent O-Ring failure.



1. Unscrew the endcap of the thermal barrier.



2. Stretch the O-Ring over the endcap so it sits in the groove just beneath the knurled shoulder.

**Securing the Compression Fitting:** The compression fitting is used with the HiTemp140-FP and HiTemp140-PT data loggers to ensure a water tight seal.

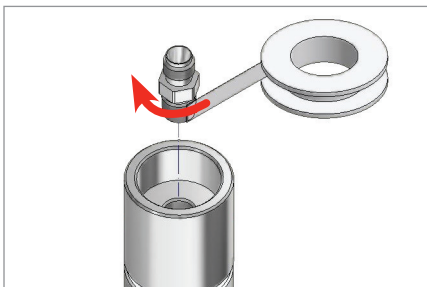

1. Wrap the provided PTFE thread sealing tape around the Fitting Body threads.



2. Screw the Fitting Body into the end of the stopper assembly (finger-tight).

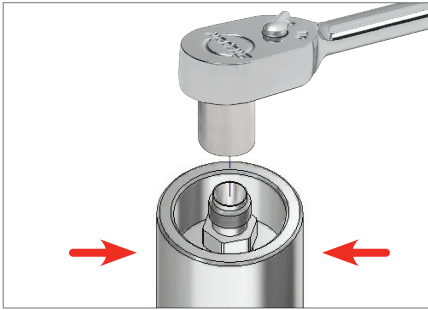

3. Holding the smooth metal end of the stopper, use a 7/16" wrench or socket to tighten the body into the stopper.

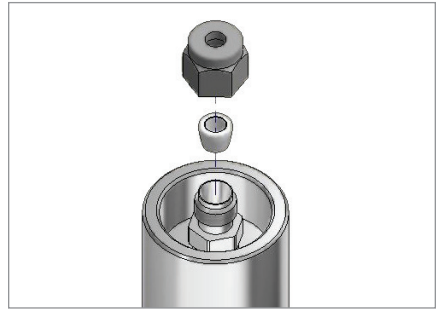

4. Insert the Compression Ferrule into the Fitting Body and hold it in place loosely with the Dome Nut.

**Compression Ferrule Note:** The stainless steel Ferrule provides the most reliable seal, but becomes permanent crimped onto the probe. The PTFE Ferrule will become more deformed with multiple uses and will eventually require replacement. It's benefit is that it allows easy removal and repositioning of the probe.



5. Feed the data logger probe through the Compression Fitting until the base of the probe is tightly against the Dome Nut.



6. Tighten the Dome Nut to secure the data logger in place (finger-tight).



7. Insert the data logger and stopper assembly back into the thermal barrier and screw the endcap of the thermal barrier until the O-Ring is no longer visible.

## General Specifications

<b>Operating Environment</b>	Refer to the Time vs. Temperature Chart
<b>IP Rating</b>	IP68 rating may be obtained with seal kit installed from -60 °C to 250 °C. Rapid temperature fluctuations may cause ingress.
<b>Barrier Materials</b>	316 Stainless Steel, PTFE, Silicone
<b>Barrier Dimensions</b>	1.75 in OD x 9.6 in L (44.45 mm OD x 243.8 mm L)
<b>Compatible Data Loggers</b>	HiTemp140-FP, HiTemp140-PT and *HiTemp140-M12 (probe dependant)
<b>Barrier Weight</b>	3.0 lb (1350 g)
<b>Max Sustainable Pressure</b>	60 PSIA

\*When using the ThermoVault Max with the HiTemp140-M12 data logger, only certain M12 probes are compatible. Please consult with the a MadgeTech Sales Representative for more information.

## Time vs. Temperature Chart

Ambient Temperature	Maximum Exposure Time (air)	Maximum Exposure Time (liquid)
-200 °C	128 minutes	n/a
-180 °C	137 minutes	n/a
-160 °C	148 minutes	n/a
-140 °C	163 minutes	n/a
-120 °C	183 minutes	n/a
-100 °C	213 minutes	n/a
-80 °C	263 minutes	n/a
-60 °C	368 minutes	319 minutes
-40 °C to +140 °C	Indefinitely	Indefinitely
150 °C	601 minutes	542 minutes
160 °C	468 minutes	414 minutes
170 °C	396 minutes	345 minutes
180 °C	348 minutes	300 minutes
190 °C	313 minutes	266 minutes
200 °C	286 minutes	241 minutes
210 °C	265 minutes	221 minutes
220 °C	247 minutes	204 minutes
230 °C	233 minutes	190 minutes
240 °C	220 minutes	178 minutes
250 °C	209 minutes	168 minutes
260 °C	200 minutes	n/a
270 °C	192 minutes	n/a
280 °C	184 minutes	n/a
290 °C	178 minutes	n/a
300 °C	172 minutes	n/a
310 °C	166 minutes	n/a
320 °C	161 minutes	n/a
330 °C	157 minutes	n/a
340 °C	153 minutes	n/a
350 °C - 400 °C	60 minutes	n/a

Please consult the measurement range of your data logger for temperatures over 250 °C (482 °F). The thermal barrier extends the operating temperature of the data logger up to, but not exceeding the measurement range.

## Disclaimer & Terms of Use

Listed specifications can be used to determine maximum allowable exposure times for the HiTemp140 with ThermoVault Max. The barrier extends the operating temperature of the logger up to, but not exceeding, the measurement range. Please consult the measurement range of the probe for temperatures above 250 °C (482 °F).

Both the data logger and ThermoVault Max must be at ambient temperature, approximately 25 °C (77 °F) before being placed in the extreme temperature environment. Immediately following exposure to high temperature, the data logger should be removed from the ThermoVault Max, using appropriate precautions, as it could be VERY hot. Failing to remove the data logger may allow heat trapped in the ThermoVault Max to continue to heat the data logger to potentially unsafe levels.

The ThermoVault Max may take hours to fully cool down. Even if the exterior of the ThermoVault Max is cool to the touch, the interior of the barrier and its contents may still be VERY hot.

The ThermoVault Max is primarily intended for use in dry air environments, but with the addition of the TMAX Wet Seal Kit, the ThermoVault Max may also be used in liquids and steam environments.

If your application involves a ramp up to a temperature above 150 °C (302 °F) and/or any complex temperature profile that isn't a constant process, please contact MadgeTech to determine whether the HiTemp140 with ThermoVault Max is suitable for the application.

To determine if the HiTemp140 with ThermoVault Max is suitable for the application, please provide MadgeTech with a detailed description of your process, including temperatures, durations, ramp times and process media such as air, steam, oil or water. If MadgeTech is unable to definitively calculate the suitability of our product for your application, a test unit outfitted with a high temperature indicator can be provided.

## Need Help?

### Product Information & Troubleshooting:

- » Visit our Knowledge Base online at [www.madgetech.com/kbase](http://www.madgetech.com/kbase).
- » Contact our friendly Customer Support Team at (603) 456-2011 or [support@madgetech.com](mailto:support@madgetech.com).

### Software Information & Support:

- » Refer to the built-in help section of the MadgeTech 4 Software.
- » Download the MadgeTech 4 Software Manual at:  
[www.madgetech.com/mt4-software-manual.pdf](http://www.madgetech.com/mt4-software-manual.pdf)



MadgeTech, Inc • 6 Warner Road • Warner, NH 03278  
Phone: (603) 456-2011 • Fax: (603) 456-2012 • [www.madgetech.com](http://www.madgetech.com)