

Autonics

Photoelectric Sensor BJ SERIES

INSTRUCTION MANUAL



Thank you for choosing our Autonics product.
Please read the following safety considerations before use.

■ Safety Considerations

- ⚠ Please observe all safety considerations for safe and proper product operation to avoid hazards.
- ⚠ symbol represents caution due to special circumstances in which hazards may occur.
- Warning** Failure to follow these instructions may result in serious injury or death.
- Caution** Failure to follow these instructions may result in personal injury or product damage.

- Warning**
- 1. **Fall-safe device must be installed when using the unit with machinery that may cause serious injury or substantial economic loss.** (e.g. nuclear power control, medical equipment, ships, vehicles, railways, aircraft, combustion apparatus, safety equipment, crime/disaster prevention devices, etc.)
- 2. **Do not disassemble or modify the unit.**
- 3. **Do not connect, repair, or inspect the unit while connected to a power source.**
- 4. **Check 'Connections' before wiring.**

- Caution**
- 1. **Use the unit within the rated specifications.**
- 2. **Use dry cloth to clean the unit, and do not use water or organic solvent.**
- 3. **Do not use the unit in the place where flammable/explosive/corrosive gas, humidity, direct sunlight, radiant heat, vibration, impact, or salinity may be present.**

■ Ordering Information

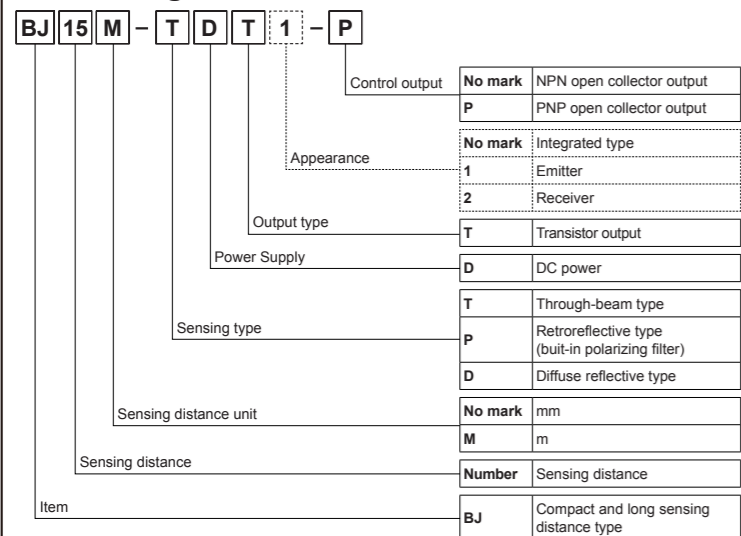

⚠ This information is intended for product management of through-beam type.
(no need to refer when selecting model)

⚠ The above specifications are subject to change and some models may be discontinued without notice.
⚠ Be sure to follow cautions written in the instruction manual and the technical descriptions (catalog, homepage).

■ Specifications

Model	BJ15M-TDT	BJ10M-TDT	BJ7M-TDT	BJ3M-PDT	BJ1M-DDT	BJ300-DDT	BJ100-DDT
NPN open collector output	BJ15M-TDT-P	BJ10M-TDT-P	BJ7M-TDT-P	BJ3M-PDT-P	BJ1M-DDT-P	BJ300-DDT-P	BJ100-DDT-P
PNP open collector output	BJ15M-TDT-P	BJ10M-TDT-P	BJ7M-TDT-P	BJ3M-PDT-P	BJ1M-DDT-P	BJ300-DDT-P	BJ100-DDT-P
Sensing type	Through-beam type			Retroreflective type (built-in polarizing filter)	Diffuse reflective type		
Sensing distance	15m	10m	7m	3m ^{※1}	1m ^{※2}	300mm ^{※3}	100mm ^{※3}
Sensing target	Opaque material over Ø12mm			Opaque material over Ø8mm	Opaque, translucent materials		
Hysteresis	—			Max. 20% at sensing distance			
Response time	Max. 1ms						
Power supply	12-24VDC±10% (ripple P-P: max. 10%)						
Current consumption	Emitter / Receiver: max. 20mA			Max. 30mA			
Light source	Infrared LED (850nm)	Red LED (660nm)	Red LED (660nm)	Red LED (660nm)	Infrared LED (850nm)	Red LED (660nm)	Infrared LED (850nm)
Sensitivity adjustment	Sensitivity adjuster						
Operation mode	Light ON/Dark ON selectable by switch						
Control output	NPN or PNP open collector output			• Load current: max. 100mA			
Protection circuit	Power reverse polarity protection circuit, output short over current protection circuit			• Residual voltage - NPN: max. 1VDC, PNP: max. 2.5VDC			
Indicator	Operation indicator: red, stability indicator: green (emitter's power indicator: green)						
Insulation resistance	Over 20MΩ (at 500VDC megger)						
Noise immunity	±240V the square wave noise (pulse width: 1μs) by the noise simulator						
Dielectric strength	1,000VAC 50/60Hz for 1minute						
Vibration	1.5mm amplitude at frequency of 10 to 55Hz (for 1 min) in each X, Y, Z direction for 2 hours						
Shock	500m/s ² (approx. 50G) in X, Y, Z direction for 3 times						
Environment	Ambient illu. Sunlight: max. 11,000lx, incandescent lamp: max. 3,000lx (receiver illumination)						
Protection structure	IP65 (IEC standard)						
Material	Case: Polycarbonate+Acrylonitrile-Butadiene-Styrene, LED Cap: Polycarbonate, Sensing part: Polymethyl methacrylate						
Cable	Ø3.5mm, 3-wire, 2m (emitter of through-beam type: Ø3.5mm, 2-wire, 2m) (AWG24, core diameter: 0.08mm, number of cores: 40, insulator out diameter: Ø1mm)						
Accessories	Common	Mounting bracket, M3 bolt: 4, M3 nut: 4, adjustment screwdriver	Mounting bracket, M3 bolt: 2, M3 nut: 2, adjustment screwdriver	Reflector (MS-2A)	—		
Approval	CE						
Unit weight	Approx. 90g			Approx. 60g		Approx. 45g	

※1: The sensing distance is specified with using the MS-2A reflector. The distance between the sensor and the reflector should be set over 0.1m. If reflector MS-2S, MS-3S (sold separately) are used, sensing distance will be lengthened as 0.1 to 4m, 0.1 to 5m. When using reflective tapes, the reflectivity will vary by the size of the tape. Please refer to the catalog or web site.
※2: Non-glossy white paper 300×300mm. ※3: Non-glossy white paper 100×100mm.
※The temperature or humidity mentioned in Environment indicates a non freezing or condensation.

■ Dimensions

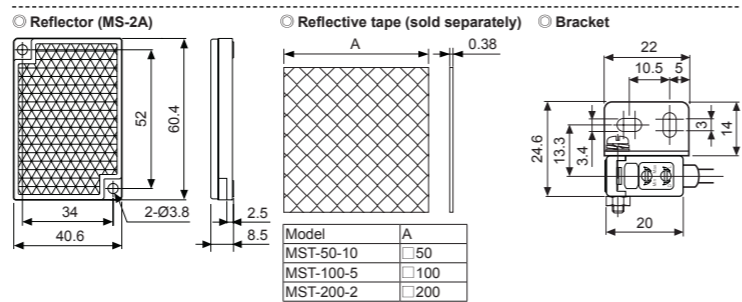
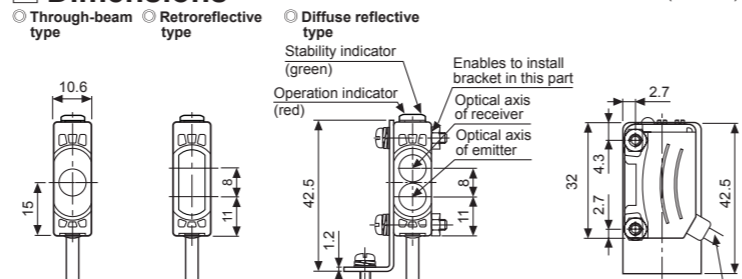

■ Connections

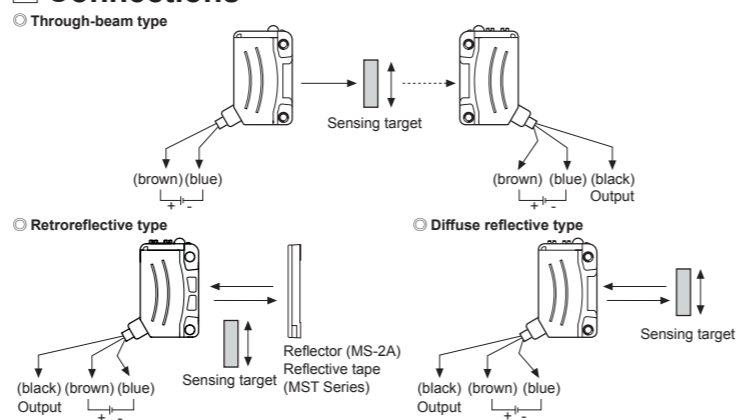

■ Operation Mode

Operation mode	Light ON	Dark ON
Receiver operation	Received light Interrupted light	Received light Interrupted light
Operation indicator (red LED)	ON OFF	ON OFF
Transistor output	ON OFF	ON OFF

■ Installation and Adjustment

⦿ **For mounting**
When using the reflective type photoelectric sensors closely over three units, it may result in malfunction due to mutual interference. When using the through-beam type photoelectric sensors closely over two units, it may result in malfunction due to mutual interference. When installing the product, tighten the screw with a tightening torque of 0.5N·m.

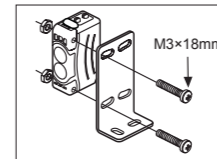

⦿ Operation mode switching

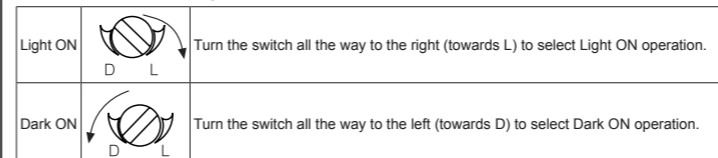

※For through-beam type, the switch is built-in the receiver.

⦿ Optical axis adjustment

1. Place the emitter and the receiver facing each other and supply the power.
 2. After adjusting the position of the emitter and the receiver and check their stable indicating range, mount them in the middle of the range.
 3. After mounting this unit, check the operation of the sensor and lighting of the stability indicator in both status. (none or sensing target status)
- ※If the sensing target is translucent body or smaller than Ø12mm, it may not sense the target because light is passed.

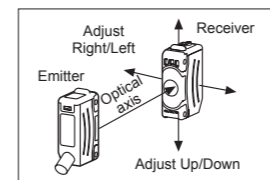

⦿ Retroreflective type

1. Place the sensor and the reflector (or reflective tape) facing each other and supply the power.
 2. After adjusting the position of the sensor and reflector (or reflective tape) and checking their stable indicating range, mount them in the middle of the range. (none or sensing target status)
 3. After mounting this unit, check the operation of the sensor and lighting of the stability indicator in both status. (none or sensing target status)
- ※Please use reflective tape (MST Series) for where a reflector is not installed.

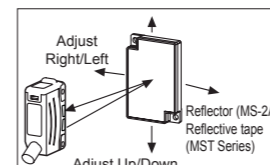

⦿ Diffuse reflective type

1. Place the emitter and the receiver facing each other and supply the power.
2. After adjusting the position of the emitter and the receiver and check their stable indicating range, mount them in the middle of the range.
3. After mounting this unit, check the operation of the sensor and lighting of the stability indicator in both status. (none or sensing target status)

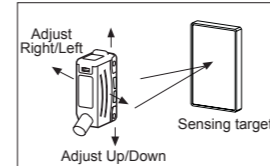

⦿ Sensitivity adjustment

Order	Sensitivity setting	Descriptions
1	(A) Min Max	From Light ON status, turn the sensitivity setting adjuster slowly to the right from Min sensitivity and check the position where operation indicator turns on (A).
2	(A) Min Max (B) (C)	From Dark ON status, turn the sensitivity setting adjuster further right and check the position where the operation indicator turns on (B). Turn the adjuster left and check the position where the operation indicator turns off (C). ※If the operation indicator does not turn on at Max sensitivity, the maximum sensitivity setting is set at position (C).
3	(A) Min Max (C)	Set the adjuster at the center position (A) and (C) for optimal sensitivity. Also, check if the stability indicator turns off with or without the sensing target. If it does not turn off, please review the operation mode again, as sensitivity may be unstable.

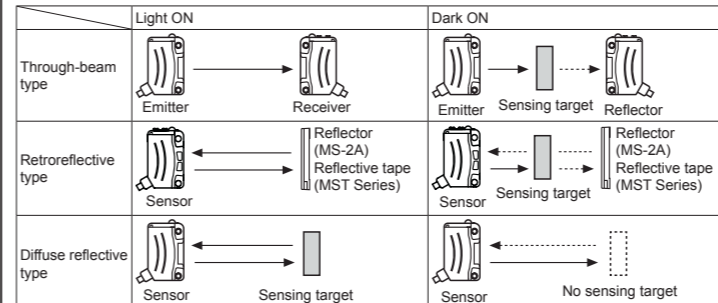

※Please set the sensitivity setting adjuster is executed in stable Light ON area and the reliability of environment (temperature, supply, dust etc.) is increased after the mounting it in a stable area.
※When adjusting sensitivity or switching operation modes, please use the Autonics adjustment screwdriver. Using a screwdriver with a bigger diameter than the adjuster buttons may cause errors when making adjustments.
※It may cause breakdown when the sensitivity setting adjuster or the operation mode selection switch is turned by force.

■ Operating Timing Diagram

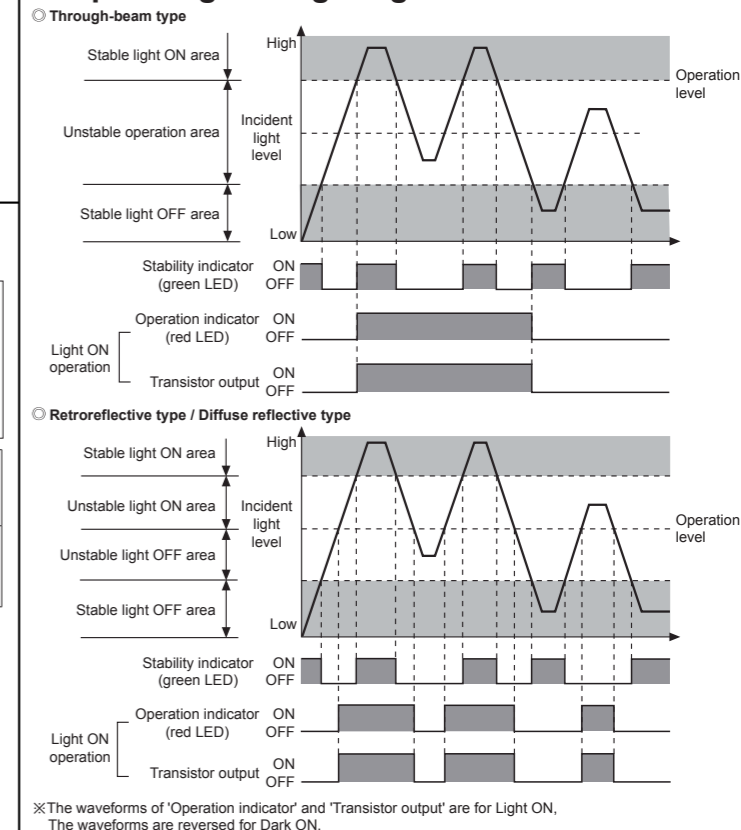

※The waveforms of 'Operation indicator' and 'Transistor output' are for Light ON. The waveforms are reversed for Dark ON.

■ Control Output Circuit Diagram

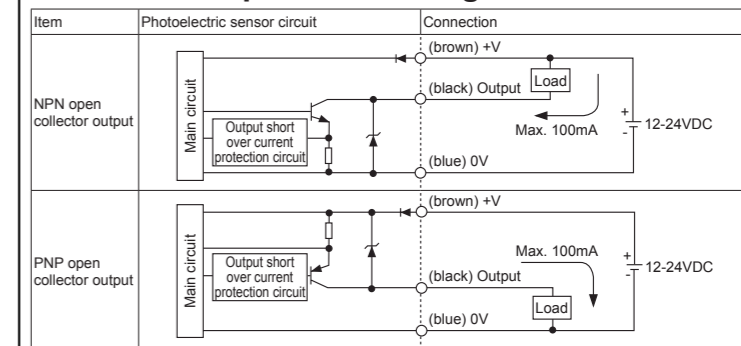

※If short-circuit the control output terminal or supply current over the rated specification, normal control signal is not output due to the output short over current protection circuit.

■ Cautions during Use

1. Follow instructions in 'Cautions during Use'. Otherwise, it may cause unexpected accidents.
2. When connecting a DC relay or other inductive load to the output, remove surge by using diodes or varistors.
3. Use the product, 0.5 sec after supplying power. When using separate power supply for the sensor and load, supply power to sensor first.
4. 12-24VDC power supply should be insulated and limited voltage/current or Class 2, SELV power supply device.
5. Wire as short as possible and keep away from high voltage lines or power lines, to prevent inductive noise.
6. When using switching mode power supply to supply the power, ground F.G. terminal and connect a condenser between 0V and F.G. terminal to remove noise.
7. When using sensor with the equipment which generates noise (switching regulator, inverter, servo motor, etc.), ground F.G. terminal of the equipment.
8. This unit may be used in the following environments.
 - ①Indoors (in the environment condition rated in 'Specifications')
 - ②Altitude max. 2,000m
 - ③Pollution degree 3
 - ④Installation category II

■ Major Products

- Photoelectric Sensors
- Fiber Optic Sensors
- Door Sensors
- Door Side Sensors
- Area Sensors
- Proximity Sensors
- Pressure Sensors
- Rotary Encoders
- Connectors/Sockets
- Switching Mode Power Supplies
- Control Switches/Lamps/Buzzers
- I/O Terminal Blocks & Cables
- Stepper Motors/Drivers/Motion Controllers
- Graphic/Logic Panels
- Field Network Devices
- Laser Marking System/Fiber, CO₂, Nd: YAG
- Laser Welding/Cutting System
- Temperature Controllers
- Temperature/Humidity Transducers
- SSRs/Power Controllers
- Counters
- Timers
- Panel Meters
- Tachometers/Pulse(Rate)/Meters
- Display Units
- Sensor Controllers

Autonics Corporation
http://www.autonics.com

HEADQUARTERS:
18, Bansong-ro 513beon-gil, Haeundae-gu, Busan, South Korea, 48002
TEL: 82-51-519-3232
E-mail: sales@autonics.com