



SMART FORCE AND TORQUE SENSORS

User's Guide

MARK-10®

Thank you...

Thank you for purchasing a Mark-10 Plug & Test™ remote sensor, designed for use with Mark-10 models 7i, 5i and 3i force/torque indicators.

With proper usage, we are confident that you will get many years of great service with this product. Mark-10 sensors are ruggedly built for many years of service in laboratory and industrial environments.



This User's Guide provides setup, safety, and operation instructions for each individual sensor series. Instructions for using models 5i and 3i indicators are available in their respective user's guides. For additional information or answers to your questions, please do not hesitate to contact us. Our technical support and engineering teams are eager to assist you.

Before use, each person who is to use Mark-10 sensors and indicators should be fully trained in appropriate operation and safety procedures.

TABLE OF CONTENTS

| | |
|---------------------------------|----|
| OVERVIEW | 2 |
| SAFETY / PROPER USAGE | 3 |
| SETUP | 4 |
| SERIES R01 FORCE SENSORS | 5 |
| SERIES R02 FORCE SENSORS | 6 |
| SERIES R03 FORCE SENSORS | 7 |
| SERIES R04 FORCE SENSORS | 8 |
| SERIES R05 FORCE SENSORS | 9 |
| SERIES R06 FORCE SENSORS | 10 |
| SERIES R50 TORQUE SENSORS | 11 |
| SERIES R51 TORQUE SENSORS | 13 |
| SERIES R52 TORQUE SENSORS | 15 |
| SERIES R53 TORQUE SENSORS | 16 |
| SERIES R55 TORQUE SENSORS | 17 |

1 OVERVIEW

1.1 General Overview

Plug & Test™ sensors accommodate numerous force and torque measurement requirements, from 0.25 to 10,000 lbF (1 N to 50 kN) of force, and from 10 ozFin to 5,000 lbFin (7 Ncm to 550 Nm) of torque. These sensors can be handheld or mounted to a fixture or test stand for more sophisticated testing requirements.

Plug & Test™ sensors are used with Mark-10 7i, 5i, and 3i indicators. They may be disconnected from one indicator and connected to another without the need for re-calibration or re-configuration. All such data is saved within a PCB located inside the smart connector.

The model number, serial number, and capacity of the sensor are identified in the rectangular label located on the connector. The model and serial numbers are also identified in the **Information** screen of the indicator. Refer to the indicator user's guides for more information.

1.2 Accuracy and Resolution

Indicator accuracy must be combined with sensor accuracy to determine the total accuracy of the system. Since sensors may be used with the 7i, 5i or 3i indicators, the accuracy of the indicator being used must be identified and taken into account, as follows:

| Indicator Model | Accuracy |
|-----------------|---------------------|
| 7i / 5i | ±0.1% of full scale |
| 3i | ±0.2% of full scale |

The total system accuracy can be calculated by adding the sensor accuracy and indicator accuracy. Refer to the following examples:

Example 1

Model MR01-100 sensor with Model 5i Indicator

| | | | | |
|---|---|----------------------------------|---|--------------------------------------|
| MR01-100 ±0.15% of full scale | + | 5i ±0.1% of full scale | = | Total ±0.25% of full scale |
|---|---|----------------------------------|---|--------------------------------------|

This translates into a fixed error of up to:
 $0.25\% \times 100 \text{ lbF} = 0.25 \text{ lbF}$

Example 2

Model MR50-50Z sensor with Model 3i Indicator

| | | | | |
|---|---|----------------------------------|---|--------------------------------------|
| MR50-50Z ±0.35% of full scale | + | 3i ±0.2% of full scale | = | Total ±0.55% of full scale |
|---|---|----------------------------------|---|--------------------------------------|

This translates into a fixed error of up to:
 $0.55\% \times 50 \text{ ozFin} = 0.275 \text{ ozFin}$

Because accuracy is defined as a *percentage of full scale*, the fixed error is possible anywhere on the scale from 0 to the capacity. As such, this value represents an increasingly large error as *percentage of reading* towards the low end of the scale. It is, therefore, recommended that a sensor is selected with capacity as close as possible to the expected load.

The resolution may be different for some sensors depending on whether a 7i, 5i, or 3i indicator is being

used. For example, a Series R01 force sensor will display finer resolution when connected to a 5i indicator than when connected to a 3i indicator. Resolution information is shown in the following sections.

2 SAFETY / PROPER USAGE

Read through the following safety instructions thoroughly before using a sensor:

1. Note the sensor's capacity before use and ensure that the capacity is not exceeded. Producing a load greater than the indicated safe overload value can damage the sensor. An overload can occur whether the sensor's indicator is powered on or off.
2. In order to extend the life of the sensor, avoid repetitive shock and impact loading.
3. When moving the sensor to another location, never lift from the cable or strain relief. This can cause damage to the sensor. Always lift the sensor housing itself.
4. Always ensure that load is applied axially with respect to the sensor.
5. Ensure that the sensor is kept away from water or any other electrically conductive liquids at all times.
6. The sensor and indicator should be serviced by a trained technician only. AC power must be disconnected and the indicator must be powered off before the housing is opened.
7. Always consider the characteristics of the sample being tested before initiating a test. A risk assessment should be carried out beforehand to ensure that all safety measures have been addressed and implemented.
8. Typical materials able to be tested include many manufactured items, such as springs, electronic components, fasteners, caps, films, mechanical assemblies, and many others. Items that should not be used with the sensor include potentially flammable substances or products, items that can shatter in an unsafe manner, and any other components that can present an exceedingly hazardous situation when acted upon by a force. Always wear eye and face protection when testing, especially in aforementioned hazardous cases. Extra bodily protection should be worn if a destructive failure of a test sample is possible.
9. In aforementioned hazardous situations, it is strongly recommended that a machine guarding system be employed to protect the operator and others in the vicinity from shards or debris.
10. Sensors have threaded holes or chucks, designed for the mounting of grips, fixtures, or attachments. If any such accessories are used, ensure they are mounted firmly to prevent a potential safety risk to the operator and others in the vicinity. If using an accessory from a supplier other than Mark-10, ensure that it is constructed of suitably rugged materials and components. Similar precautions should be taken when mounting the sensor to a test stand, work bench, or other piece of equipment.

3 SETUP

The Plug & Test™ connector must be inserted into the receptacle of the indicator with the side marked “Plug & Test™ Technology” facing up (see Fig. 3.1). When fully inserted, the connector will lock into place with a “click”.



Fig. 3.1
Appropriate orientation of the Plug & Test™ connector.

To release the connector, press both buttons on either side of the indicator housing (see Fig. 3.2). Pull the connector completely out of the indicator by holding the curved aluminum section. **DO NOT** pull on the cable or strain relief.



Fig. 3.2
Press both buttons on either side of the indicator housing to release the Plug & Test™ connector.

4 SERIES R01 FORCE SENSORS

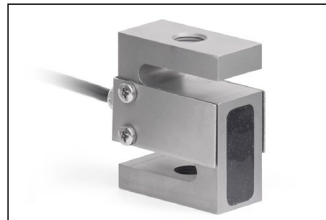

4.1 Unpacking and Assembly

Carefully remove the sensor from the box. No assembly is required.

4.2 Overview

Tension and compression force may be applied to the surfaces with threaded holes. Attachments may be threaded into these holes. These holes also allow for mounting as required.

4.3 Specifications

| | |
|------------------------|---|
| Accuracy: | ±0.15% of full scale |
| Safe overload: | 150% of full scale |
| Operating temperature: | 40°F – 100°F [5°C – 38°C] |
| Operating humidity: | 96% max. (non-condensing) |
| Weight: | 1.9 to 3.0 lb [0.9 to 1.4 kg], depending on model |

4.4 Dimensions (in [mm])

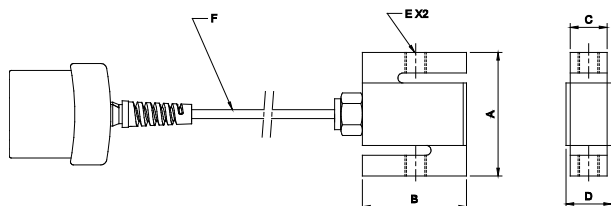

| Model No. | A | B | C | D | E | F | | |
|------------|----------------|----------------|----------------|----------------|---------------|----------------------------|---------------|--------------------------------|
| MR01-50 | 2.40 [61.0] | 2.00 [50.8] | 0.46 [11.7] | 0.90 [22.9] | 1/4-28 UNF | MR01-XXXXX: 20 ft [6 m] | | |
| MR01-100 | | | | | | | | |
| MR01-200 | | | | | | | | |
| MR01-300 | | | | | | | | |
| MR01-500 | | | 0.71 [18.0] | 1.10 [27.9] | | | 1/2-20 UNF | MR01-XXXX-1: 10 in [254 mm] |
| MR01-750 | | | | | | | | |
| MR01-1000 | | | | | | | | |
| MR01-1500 | | | 0.96 [24.4] | 1.40 [35.6] | | | | |
| MR01-2000 | | | | | | | | |
| MR01-5000 | | | 3.90 [99.1] | 3.00 [76.2] | | | | |
| MR01-10000 | | | | | | | | |

4.5 Capacity x Resolution

| Model No. | With Model 7i / 5i Indicator | | | | | | With Model 3i Indicator | | | |
|------------|------------------------------|------------|------------|------------|------------|--------------|-------------------------|-----------|------------|-----------|
| | lbF | ozF | gF | kgF | N | kN | lbF | kgF | N | kN |
| MR01-50 | 50 x 0.02 | 800 x 0.5 | 25000 x 10 | 25 x 0.01 | 250 x 0.1 | - | 50 x 0.05 | 25 x 0.02 | 250 x 0.2 | - |
| MR01-100 | 100 x 0.05 | 1600 x 1 | 50000 x 20 | 50 x 0.02 | 500 x 0.2 | - | 100 x 0.1 | 50 x 0.05 | 500 x 0.5 | - |
| MR01-200 | 200 x 0.1 | 3200 x 2 | - | 100 x 0.05 | 1000 x 0.5 | 1 x 0.0005 | 200 x 0.2 | 100 x 0.1 | 1000 x 1 | - |
| MR01-500 | 500 x 0.2 | 8000 x 5 | - | 250 x 0.1 | 2500 x 1 | 2.5 x 0.001 | 500 x 0.5 | 250 x 0.2 | 2500 x 2 | - |
| MR01-300 | 300 x 0.2 | 4800 x 5 | - | 150 x 0.1 | 1500 x 1 | 1.5 x 0.001 | 300 x 0.5 | 150 x 0.2 | 1500 x 2 | - |
| MR01-750 | 750 x 0.5 | 12000 x 10 | - | 375 x 0.2 | 3750 x 2 | 3.75 x 0.002 | 750 x 0.5 | 375 x 0.2 | 3750 x 2 | - |
| MR01-1000 | 1000 x 0.5 | 16000 x 10 | - | 500 x 0.2 | 5000 x 2 | 5 x 0.002 | 1000 x 1 | 500 x 0.5 | 5000 x 5 | - |
| MR01-1500 | 1500 x 1 | 24000 x 20 | - | 750 x 0.5 | 7500 x 5 | 7.5 x 0.005 | 1500 x 2 | 750 x 1 | 7500 x 10 | - |
| MR01-2000 | 2000 x 1 | 32000 x 20 | - | 1000 x 0.5 | 10000 x 5 | 10 x 0.005 | 2000 x 2 | 1000 x 1 | 10000 x 10 | - |
| MR01-5000 | 5000 x 2 | - | - | 2500 x 1 | 25000 x 10 | 25 x 0.01 | 5000 x 5 | 2500 x 2 | - | 25 x 0.02 |
| MR01-10000 | 10000 x 5 | - | - | 5000 x 2 | 50000 x 25 | 50 x 0.02 | 10000 x 10 | 5000 x 5 | - | 50 x 0.05 |

5 SERIES R02 FORCE SENSORS



5.1 Unpacking and Assembly

Carefully remove the sensor from the box. No assembly is required.

5.2 Overview

Compression force may be applied to the button in the center of the top surface of the sensor (visible in the picture above). **DO NOT** apply load to the cover on the underside of the sensor. Threaded holes are supplied to permit mounting to various surfaces.

5.3 Specifications

| | |
|------------------------|--|
| Accuracy: | ±0.5% of full scale |
| Safe overload: | 150% of full scale |
| Operating temperature: | 40°F – 100°F [5°C – 38°C] |
| Operating humidity: | 96% max. (non-condensing) |
| Weight: | MR02-100 - MR02-2000: 0.3 lb [0.1 kg] MR02-5000 - MR02-10000: 0.5 lb [0.2 kg] |

5.4 Dimensions (in[mm])

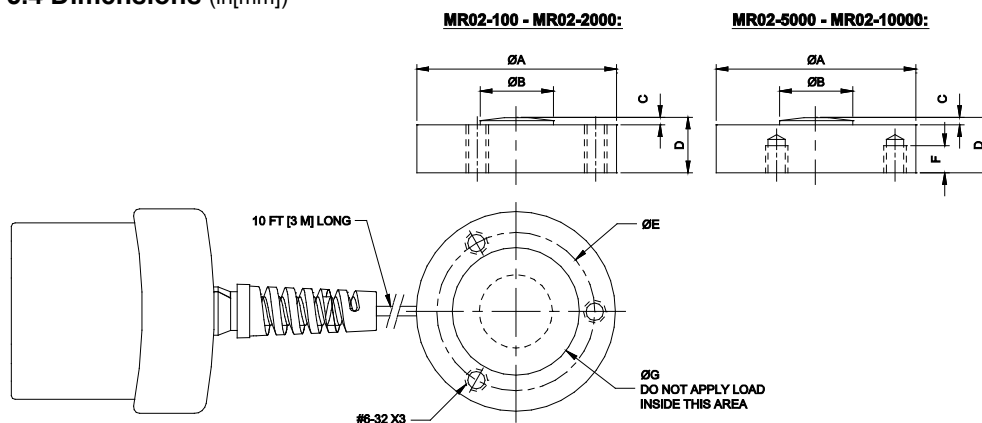

| Model | ØA | ØB | C | D | ØE | F | ØG |
|---------------------------|----------------|----------------|---------------|----------------|----------------|---------------|----------------|
| MR02-100 – MR02-2000 | 1.25 [31.8] | 0.32 [8.1] | 0.05 [1.3] | 0.39 [9.9] | 1.0 [25.4] | - | 0.83 [21.1] |
| MR02-5000 – MR02-10000 | 1.50 [38.1] | 0.43 [10.9] | 0.07 [1.8] | 0.62 [15.8] | 1.25 [31.8] | 0.25 [6.4] | 1.08 [27.4] |

5.5 Capacity x Resolution

| Model No. | With Model 7i / 5i Indicator | | | | | | With Model 3i Indicator | | | |
|------------|------------------------------|------------|------------|------------|------------|-------------|-------------------------|-----------|------------|-----------|
| | lbF | ozF | gF | kgF | N | kN | lbF | kgF | N | kN |
| MR02-100 | 100 x 0.05 | 1600 x 1 | 50000 x 20 | 50 x 0.02 | 500 x 0.2 | - | 100 x 0.1 | 50 x 0.05 | 500 x 0.5 | - |
| MR02-200 | 200 x 0.1 | 3200 x 2 | - | 100 x 0.05 | 1000 x 0.5 | 1 x 0.0005 | 200 x 0.2 | 100 x 0.1 | 1000 x 1 | - |
| MR02-500 | 500 x 0.2 | 8000 x 5 | - | 250 x 0.1 | 2500 x 1 | 2.5 x 0.001 | 500 x 0.5 | 250 x 0.2 | 2500 x 2 | - |
| MR02-1000 | 1000 x 0.5 | 16000 x 10 | - | 500 x 0.2 | 5000 x 2 | 5 x 0.002 | 1000 x 1 | 500 x 0.5 | 5000 x 5 | - |
| MR02-2000 | 2000 x 1 | 32000 x 20 | - | 1000 x 0.5 | 10000 x 5 | 10 x 0.005 | 2000 x 2 | 1000 x 1 | 10000 x 10 | - |
| MR02-5000 | 5000 x 2 | - | - | 2500 x 1 | 25000 x 10 | 25 x 0.01 | 5000 x 5 | 2500 x 2 | - | 25 x 0.02 |
| MR02-10000 | 10000 x 5 | - | - | 5000 x 2 | 50000 x 25 | 50 x 0.02 | 10000 x 10 | 5000 x 5 | - | 50 x 0.05 |

6 SERIES R03 FORCE SENSORS



6.1 Unpacking and Assembly

Carefully remove the sensor from the box. Extra care should be taken for very low capacity models. No assembly is required.

6.2 Overview

Tension and compression force may be applied to the threaded holes in the load cell shaft and opposite flat surface. Attachments may be threaded into these holes. **Finger-tighten only.** These holes also allow for mounting as required.

6.3 Specifications

| | |
|------------------------|--|
| Accuracy: | ±0.15% of full scale |
| Safe overload: | MR03-025 – MR03-2: 200% of full scale MR03-5 – MR03-100: 150% of full scale |
| Operating temperature: | 40°F – 100°F [5°C – 38°C] |
| Operating humidity: | 96% max. (non-condensing) |
| Weight: | 0.4 lb [0.2 kg] |

6.4 Dimensions (in[mm])

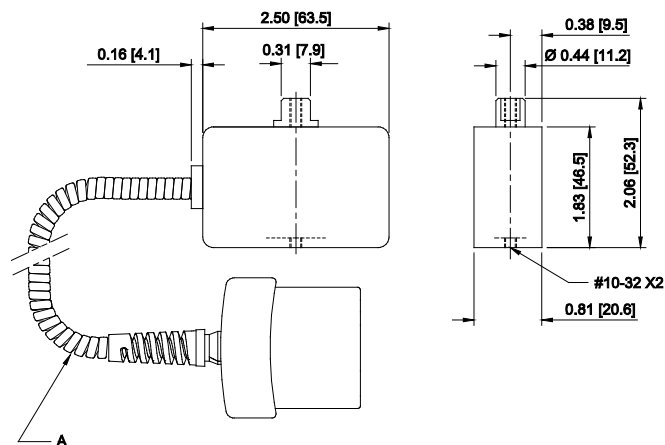

| Model No. | A |
|------------|---|
| MR03-XXX | 24 in [610 mm], coiled, when retracted 10 ft [3 m], coiled, when stretched |
| MR03-XXX-1 | 10 in [254 mm], straight |

6.5 Capacity x Resolution

| Model No. | With Model 7i / 5i Indicator | | | | | | With Model 3i Indicator | | | |
|-----------|------------------------------|-----------|------------|-------------|-------------|------------|-------------------------|-----------|-------------|-------------|
| | lbF | ozF | gF | kgF | N | mN | lbF | gF | kgF | N |
| MR03-025 | 0.25 x 0.0001 | 4 x 0.002 | 100 x 0.05 | - | 1 x 0.0005 | 1000 x 0.5 | 0.25 x 0.0002 | 100 x 0.1 | - | 1 x 0.001 |
| MR03-05 | 0.5 x 0.0002 | 8 x 0.005 | 250 x 0.1 | - | 2.5 x 0.001 | 2500 x 1 | 0.5 x 0.0005 | 250 x 0.2 | - | 2.5 x 0.002 |
| MR03-2 | 2 x 0.001 | 32 x 0.02 | 1000 x 0.5 | 1 x 0.0005 | 10 x 0.005 | - | 2 x 0.002 | - | 1 x 0.001 | 10 x 0.01 |
| MR03-5 | 5 x 0.002 | 80 x 0.05 | 2500 x 1 | 2.5 x 0.001 | 25 x 0.01 | - | 5 x 0.005 | - | 2.5 x 0.002 | 25 x 0.02 |
| MR03-10 | 10 x 0.005 | 160 x 0.1 | 5000 x 2 | 5 x 0.002 | 50 x 0.02 | - | 10 x 0.01 | - | 5 x 0.005 | 50 x 0.05 |
| MR03-20 | 20 x 0.01 | 320 x 0.2 | 10000 x 5 | 10 x 0.005 | 100 x 0.05 | - | 20 x 0.02 | - | 10 x 0.01 | 100 x 0.1 |
| MR03-50 | 50 x 0.02 | 800 x 0.5 | 25000 x 10 | 25 x 0.01 | 250 x 0.1 | - | 50 x 0.05 | - | 25 x 0.02 | 250 x 0.2 |
| MR03-100 | 100 x 0.05 | 1600 x 1 | 50000 x 20 | 50 x 0.02 | 500 x 0.2 | - | 100 x 0.1 | - | 50 x 0.05 | 500 x 0.5 |

7 SERIES R04 FORCE SENSORS



7.1 Unpacking and Assembly

Carefully remove the sensor from the box. Extra care should be taken for very low capacity models. No assembly is required.

7.2 Overview

Tension and compression force may be applied to the surfaces with threaded holes. Attachments may be threaded into these holes.

Finger-tighten only. These holes also allow for mounting as required.

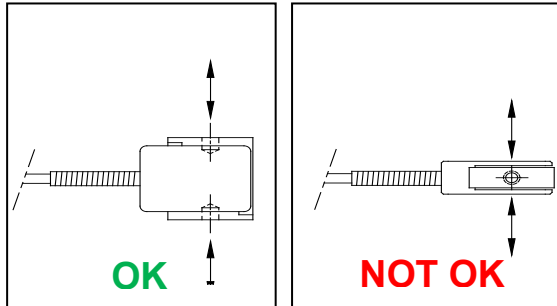

7.3 Specifications

| | |
|------------------------|---------------------------|
| Accuracy: | ±0.2% of full scale |
| Safe overload: | 200% of full scale |
| Operating temperature: | 40°F – 100°F [5°C – 38°C] |
| Operating humidity: | 96% max. (non-condensing) |
| Weight: | 0.015 lb [0.007 kg] |

7.4 Dimensions (in[mm])

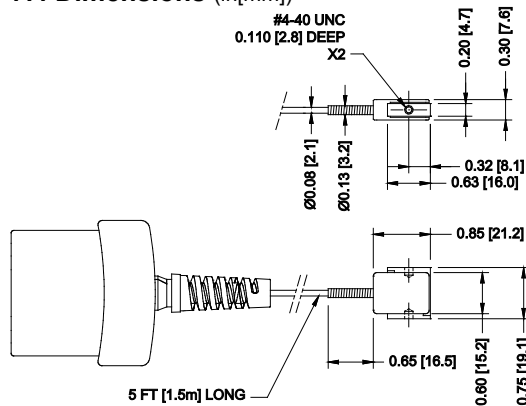

7.5 Capacity x Resolution

| Model No. | With Model 7i / 5i Indicator | | | | | | With Model 3i Indicator | | | |
|-----------|------------------------------|-----------|------------|-------------|-------------|------------|-------------------------|-----------|-------------|-------------|
| | lbF | ozF | gF | kgF | N | mN | lbF | gF | kgF | N |
| MR04-025 | 0.25 x 0.0001 | 4 x 0.002 | 100 x 0.05 | - | 1 x 0.0005 | 1000 x 0.5 | 0.25 x 0.0002 | 100 x 0.1 | - | 1 x 0.001 |
| MR04-05 | 0.5 x 0.0002 | 8 x 0.005 | 250 x 0.1 | - | 2.5 x 0.001 | 2500 x 1 | 0.5 x 0.0005 | 250 x 0.2 | - | 2.5 x 0.002 |
| MR04-2 | 2 x 0.001 | 32 x 0.02 | 1000 x 0.5 | 1 x 0.0005 | 10 x 0.005 | - | 2 x 0.002 | - | 1 x 0.001 | 10 x 0.01 |
| MR04-5 | 5 x 0.002 | 80 x 0.05 | 2500 x 1 | 2.5 x 0.001 | 25 x 0.01 | - | 5 x 0.005 | - | 2.5 x 0.002 | 25 x 0.02 |
| MR04-10 | 10 x 0.005 | 160 x 0.1 | 5000 x 2 | 5 x 0.002 | 50 x 0.02 | - | 10 x 0.01 | - | 5 x 0.005 | 50 x 0.05 |
| MR04-20 | 20 x 0.01 | 320 x 0.2 | 10000 x 5 | 10 x 0.005 | 100 x 0.05 | - | 20 x 0.02 | - | 10 x 0.01 | 100 x 0.1 |
| MR04-50 | 50 x 0.02 | 800 x 0.5 | 25000 x 10 | 25 x 0.01 | 250 x 0.1 | - | 50 x 0.05 | - | 25 x 0.02 | 250 x 0.2 |
| MR04-100 | 100 x 0.05 | 1600 x 1 | 50000 x 20 | 50 x 0.02 | 500 x 0.2 | - | 100 x 0.1 | - | 50 x 0.05 | 500 x 0.5 |

8 SERIES R05 FORCE SENSORS



8.1 Unpacking and Assembly

Carefully remove the sensor from the box. No assembly is required.

8.2 Overview

Designed for pull and push testing. Firmly grip the handles when producing tension or compression force. Force may be applied to the surface with threaded hole. Attachments may be threaded into

these holes. **Finger-tighten only.**

8.3 Specifications

Accuracy: $\pm 0.15\%$ of full scale
 Safe overload: 150% of full scale
 Operating temperature: 40°F – 100°F [5°C – 38°C]
 Operating humidity: 96% max. (non-condensing)
 Weight: 2 lb [0.9 kg]

8.4 Dimensions (in[mm])

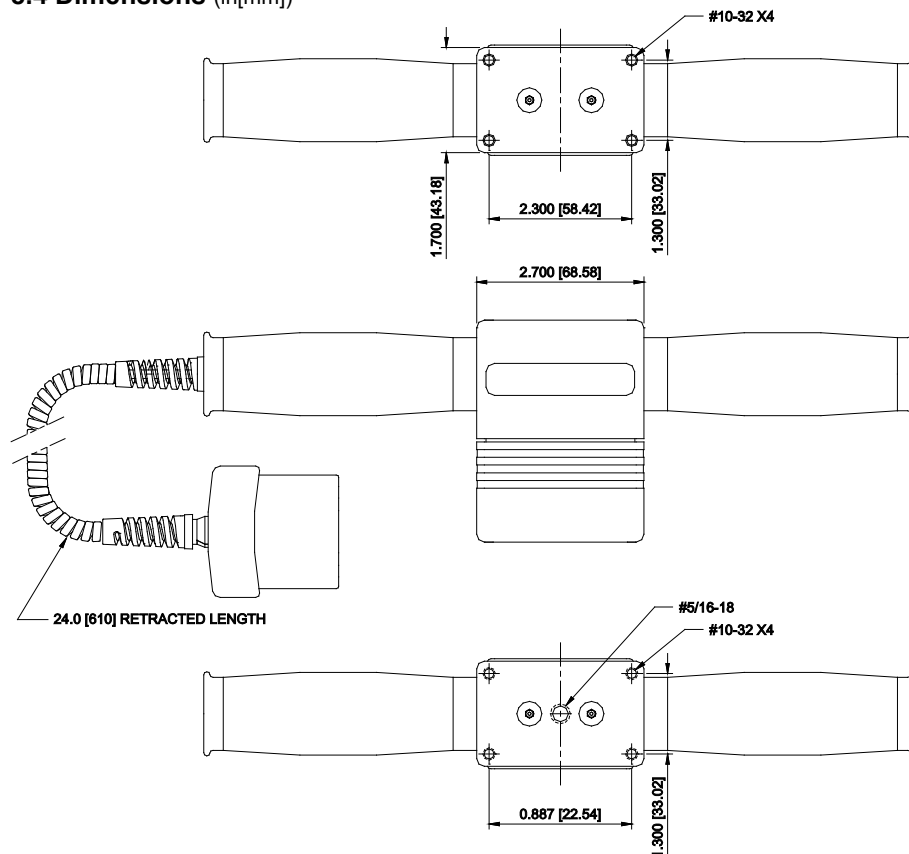

8.5 Capacity x Resolution

| Model No. | With Model 7i / 5i Indicator | | | | | With Model 3i Indicator | | |
|-----------|------------------------------|----------|-----------|----------|-------------|-------------------------|-----------|----------|
| | lbF | ozF | kgF | N | kN | lbF | kgF | N |
| MR05-500 | 500 x 0.2 | 8000 x 5 | 250 x 0.1 | 2500 x 1 | 2.5 x 0.001 | 500 x 0.5 | 250 x 0.2 | 2500 x 2 |

9 SERIES R06 FORCE SENSORS

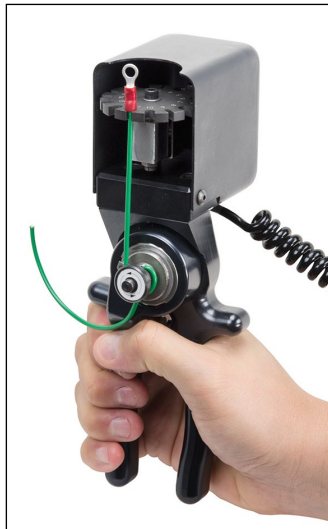

9.1 Overview

The MR06-200 is designed for field pull testing of crimped wire terminals. Carefully remove the sensor from the box. No assembly is required.

9.2 Instructions

Rotate the upper grip to an appropriately sized slot. Depress the cam shaft button, located in the tensioning mechanism, and insert the end of the wire sample in the hole located in the cam shaft. Release the cam shaft button. Wrap the wire at least one full clockwise turn around the cam shaft. Then insert the terminal lead in the slot on the upper grip.

Begin to compress and release the handles slowly. Tension force values will be displayed on the indicator. After the test is complete, remove any debris from the upper grip assembly, and depress the button on the cam shaft to remove the wire.

9.3 Specifications

Accuracy: ±0.5% of full scale
 Safe overload: 150% of full scale
 Operating temperature: 40°F – 100°F [5°C – 38°C]
 Operating humidity: 96% max. (non-condensing)
 Weight: 2.5 lb [1.2 kg]

9.4 Dimensions (in[mm])

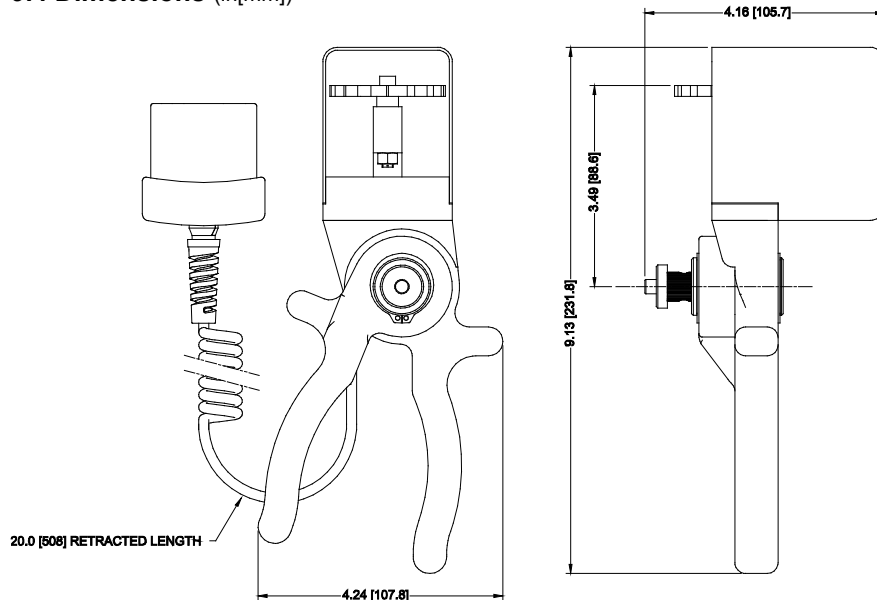

9.5 Capacity x Resolution

| Model No. | With Model 7i / 5i Indicator | | | | | With Model 3i Indicator | | |
|-----------|------------------------------|----------|------------|------------|------------|-------------------------|-----------|----------|
| | lbF | ozF | kgF | N | kN | lbF | kgF | N |
| MR06-200 | 200 x 0.1 | 3200 x 2 | 100 x 0.05 | 1000 x 0.5 | 1 x 0.0005 | 200 x 0.2 | 100 x 0.1 | 1000 x 1 |

10 SERIES R50 TORQUE SENSORS



10.1 Unpacking and Assembly

Carefully remove the sensor from the box. For models MR50-10Z, MR50-20Z, and MR50-50Z, remove the protective tubing inserted around the chuck. Save it for future transportation needs. No assembly is required.

10.2 Overview

Designed for clockwise and counter-clockwise torque testing. The sensor may be handheld or mounted to a test stand, fixture, or other equipment. Bits or fixtures may be placed in the chuck, although extra care should be taken when handling low capacity models.

10.3 Specifications

| | |
|------------------------|--|
| Accuracy: | ±0.35% of full scale |
| Safe overload: | MR50-10Z - MR50-50Z: 300% of full scale |
| | MR50-12 - MR50-100: 150% of full scale |
| Chuck opening range: | MR50-10Z - MR50-50Z: 0.062 - 0.375 in [1.6 - 9.5 mm] |
| | MR50-12 - MR50-100: 0.078 - 0.5 in [2.0 - 12.7 mm] |
| Operating temperature: | 40°F – 100°F [5°C – 38°C] |
| Operating humidity: | 96% max. (non-condensing) |
| Weight: | From 1.4 lb [0.6 kg] |

10.4 Calibration

Calibration should be performed in a vertical orientation, especially for sensors with capacities of 50 ozFin [35 Ncm] or less. Horizontal orientation subjects the sensor to side loads resulting from the weight of the chuck and attachments. Such side loads can be significant enough to skew the readings out of tolerance.

The illustration below depicts a recommended vertical setup:

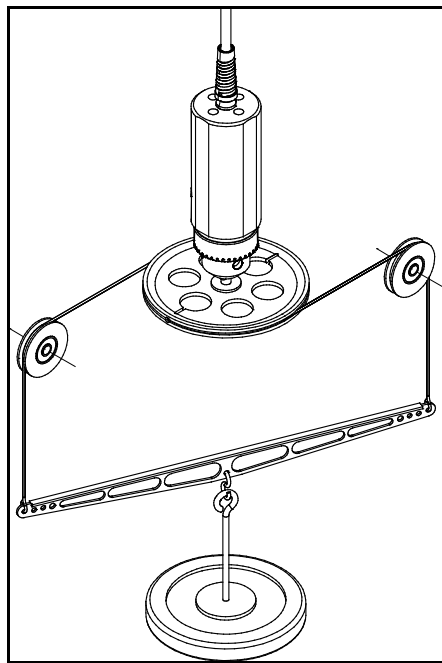

For further calibration instructions, refer to the indicator's user's guide.

10.5 Dimensions (in[mm])

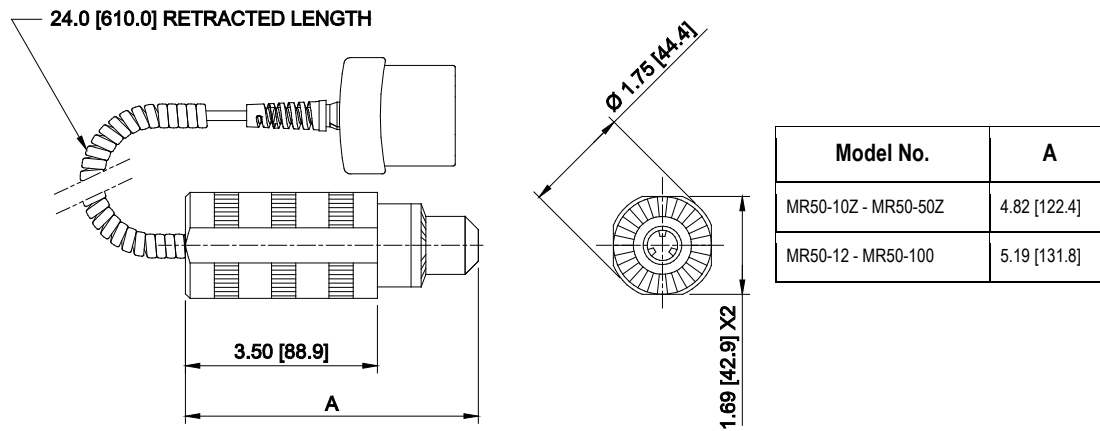

10.6 Capacity x Resolution

| Model No. | With Model 7i / 5i indicator | | | | | | | | With Model 3i indicator | | | |
|-----------|------------------------------|------------|------------|-----------|------------|-----------|------------|--------------|-------------------------|-----------|-----------|-----------|
| | ozFin | lbFin | lbFft | gFcm | kgFmm | Nmm | Ncm | Nm | ozFin | lbFin | kgFmm | Ncm |
| MR50-10Z | 10 x 0.005 | - | - | 700 x 0.5 | 7 x 0.005 | 70 x 0.05 | 7 x 0.005 | - | 10 x 0.01 | - | 7 x 0.005 | 7 x 0.005 |
| MR50-20Z | 20 x 0.01 | - | - | 1400 x 1 | 14 x 0.01 | 140 x 0.1 | 14 x 0.01 | - | 20 x 0.02 | - | 14 x 0.01 | 14 x 0.01 |
| MR50-50Z | 50 x 0.02 | - | - | 3600 x 2 | 36 x 0.02 | 350 x 0.2 | 35 x 0.02 | - | 50 x 0.05 | - | 36 x 0.05 | 35 x 0.05 |
| MR50-12 | - | 12 x 0.005 | 1 x 0.0005 | - | 140 x 0.1 | - | 135 x 0.1 | 1.35 x 0.001 | - | 12 x 0.01 | 140 x 0.1 | 135 x 0.1 |
| MR50-50 | - | 50 x 0.02 | 4 x 0.002 | - | 580 x 0.5 | - | 570 x 0.5 | 5.7 x 0.005 | - | 50 x 0.05 | 580 x 0.5 | 570 x 0.5 |
| MR50-100 | - | 100 x 0.05 | 8 x 0.005 | - | 1150 x 0.5 | - | 1150 x 0.5 | 11.5 x 0.005 | - | 100 x 0.1 | 1150 x 1 | 1150 x 1 |

11 SERIES R51 TORQUE SENSORS



11.1 Unpacking and Assembly

Carefully remove the sensor from the box. Series R51 sensors are available with three interchangeable chuck attachments and bit holder. To attach the chuck or bit holder, align the pin located on the end of the sensor body with the hole located on the attachment (see Fig. 10.1). Thread the ring onto the sensor body to keep the attachment in place.

11.2 Overview

Designed for clockwise and counter-clockwise torque testing. The sensor may be handheld or mounted to a test stand, fixture, or other equipment. Bits or fixtures may be placed in the chuck, although extra care should be taken when handling low capacity models.



11.3 Specifications

| | |
|--|--|
| Accuracy: | ±0.2% of full scale |
| Safe overload: | MR50-10Z - MR50-50Z: 300% of full scale |
| Fig. 10.1 | % of full scale |
| The attachment and main sensor body mate with a pin and threaded ring. | MR50-10Z - MR50-50Z: 0.062 - 0.375 in [1.6 - 9.5 |
| | MR50-12 - MR50-100: 0.078 - 0.5 in [2.0 - 12.7 mm] |
| | Operating temperature: 40°F – 100°F [5°C – 38°C] |
| | Operating humidity: 96% max. (non-condensing) |
| Weight: | From 1.4 lb [0.6 kg] |

11.4 Calibration

Calibration should be performed in a vertical orientation, especially for sensors with capacities of 50 ozFin [35 Ncm] or less. Horizontal orientation subjects the sensor to side loads resulting from the weight of the chuck and attachments. Such side loads can be significant enough to skew the readings out of tolerance.

The illustration below depicts a recommended vertical setup:

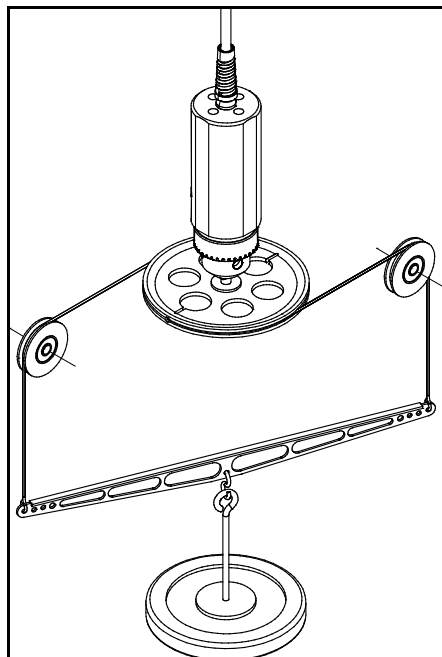

For further calibration instructions, refer to the indicator's user's guide.

11.5 Dimensions (in[mm])

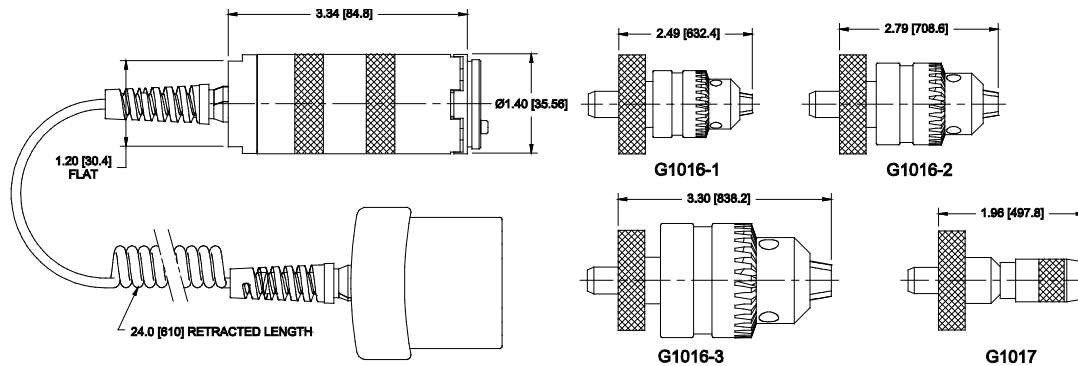

11.6 Capacity x Resolution

| Model No. | With Model 7i / 5i indicator | | | | | | | | With Model 3i indicator | | | |
|-----------|------------------------------|------------|------------|-----------|------------|-----------|------------|--------------|-------------------------|-----------|-----------|-----------|
| | ozFin | lbFin | lbFft | gFcm | kgFmm | Nmm | Ncm | Nm | ozFin | lbFin | kgFmm | Ncm |
| MR51-10Z | 10 x 0.005 | - | - | 700 x 0.5 | 7 x 0.005 | 70 x 0.05 | 7 x 0.005 | - | 10 x 0.01 | - | 7 x 0.005 | 7 x 0.005 |
| MR51-20Z | 20 x 0.01 | - | - | 1400 x 1 | 14 x 0.01 | 140 x 0.1 | 14 x 0.01 | - | 20 x 0.02 | - | 14 x 0.01 | 14 x 0.01 |
| MR51-50Z | 50 x 0.02 | - | - | 3600 x 2 | 36 x 0.02 | 350 x 0.2 | 35 x 0.02 | - | 50 x 0.05 | - | 36 x 0.05 | 35 x 0.05 |
| MR51-12 | - | 12 x 0.005 | 1 x 0.0005 | - | 140 x 0.1 | - | 135 x 0.1 | 1.35 x 0.001 | - | 12 x 0.01 | 140 x 0.1 | 135 x 0.1 |
| MR51-50 | - | 50 x 0.02 | 4 x 0.002 | - | 580 x 0.5 | - | 570 x 0.5 | 5.7 x 0.005 | - | 50 x 0.05 | 580 x 0.5 | 570 x 0.5 |
| MR51-100 | - | 100 x 0.05 | 8 x 0.005 | - | 1150 x 0.5 | - | 1150 x 0.5 | 11.5 x 0.005 | - | 100 x 0.1 | 1150 x 1 | 1150 x 1 |

13 SERIES R53 TORQUE SENSORS



13.1 Unpacking and Assembly

Carefully remove the sensor from the box. Install the four posts in the desired positions on the sliders. If alternative gripping fixtures were purchased, install them using the supplied hardware.

13.2 Overview

Designed for clockwise and counter-clockwise bottle cap torque testing. Turning the knob moves the sliders along the length of the screw to engage to disengage the sample. The posts or alternative gripping fixtures secure the sample while the cap is twisted by hand. The sensor contains threaded holes on the underside of the base for bench mounting.

13.3 Specifications

Accuracy: ±0.5% of full scale
 Safe overload: MR53-10Z - MR53-50Z: 300% of full scale / MR53-12 - MR53-100: 150% of full scale
 Operating temperature: 40°F – 100°F [5°C – 38°C]
 Operating humidity: 96% max. (non-condensing)
 Weight: MR53-10Z - MR53-50Z: 2.2 lb [1.0 kg] / MR53-12 - MR53-100: 5.4 lb [2.5 kg]

13.4 Dimensions (in[mm])

MR53-10Z - MR53-50Z:

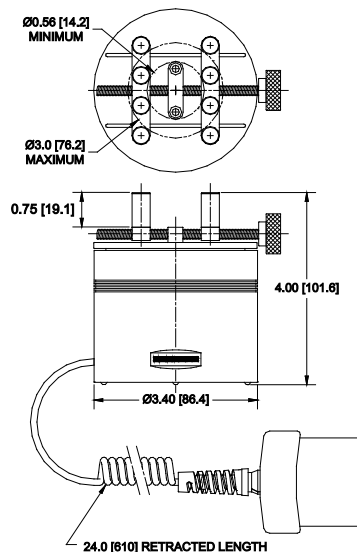

MR53-12 - MR53-100:

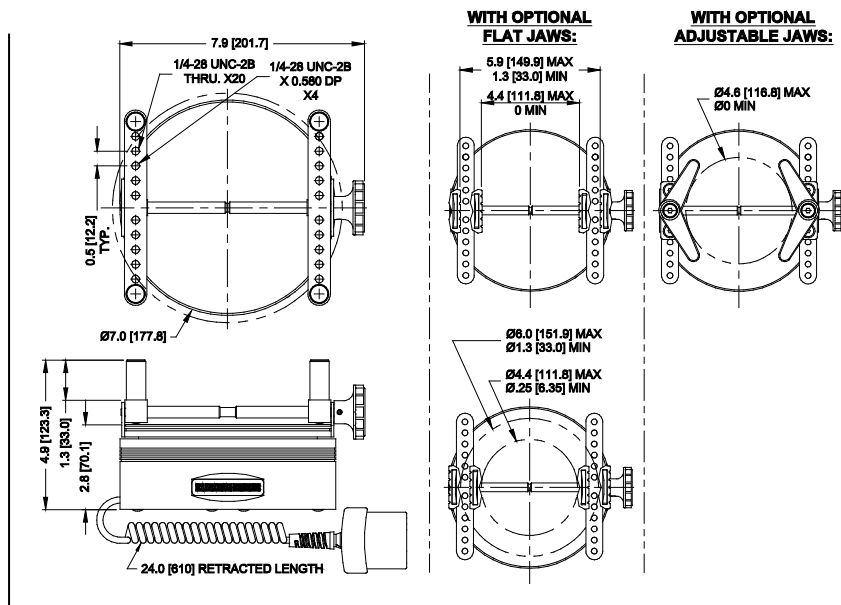

13.5 Capacity x Resolution

| Model No. | With Model 7i / 5i indicator | | | | | | | | With Model 3i indicator | | | |
|-----------|------------------------------|-----------|-----------|-----------|-----------|-----------|-----------|--------------|-------------------------|-----------|-----------|-----------|
| | ozFin | lbFin | lbFft | gFcm | kgFmm | Nmm | Ncm | Nm | ozFin | lbFin | kgFmm | Ncm |
| MR53-10Z | 10 x 0.01 | - | - | 700 x 0.5 | 7 x 0.005 | 70 x 0.05 | 7 x 0.005 | - | 10 x 0.01 | - | 7 x 0.005 | 7 x 0.005 |
| MR53-20Z | 20 x 0.02 | - | - | 1400 x 1 | 14 x 0.01 | 140 x 0.1 | 14 x 0.01 | - | 20 x 0.02 | - | 14 x 0.01 | 14 x 0.01 |
| MR53-50Z | 50 x 0.05 | - | - | 3600 x 5 | 36 x 0.05 | 350 x 0.5 | 35 x 0.05 | - | 50 x 0.05 | - | 36 x 0.05 | 35 x 0.05 |
| MR53-12 | - | 12 x 0.01 | 1 x 0.001 | - | 140 x 0.1 | - | 135 x 0.1 | 1.35 x 0.001 | - | 12 x 0.01 | 140 x 0.1 | 135 x 0.1 |
| MR53-50 | - | 50 x 0.05 | 4 x 0.005 | - | 580 x 0.5 | - | 570 x 0.5 | 5.7 x 0.005 | - | 50 x 0.05 | 580 x 0.5 | 570 x 0.5 |
| MR53-100 | - | 100 x 0.1 | 8 x 0.01 | - | 1150 x 1 | - | 1150 x 1 | 11.5 x 0.01 | - | 100 x 0.1 | 1150 x 1 | 1150 x 1 |

14 SERIES R55 TORQUE SENSORS



14.1 Unpacking and Assembly

Carefully remove the sensor from the box. No assembly is required.

14.2 Overview

Designed for clockwise and counter-clockwise torque testing. Square drives on both ends permit inline use with a torque wrench, or for use in OEM and other applications.

14.3 Specifications

Accuracy: ±0.6% of full scale
 Safe overload: 150% of full scale
 Operating temperature: 40°F – 100°F [5°C – 38°C]
 Operating humidity: 96% max. (non-condensing)
 Weight: MR55-20 – MR55-1000: 1.3 lb (0.6 kg)
 MR55-5000: 1.9 lb (0.9 kg)

14.4 Dimensions (in[mm])

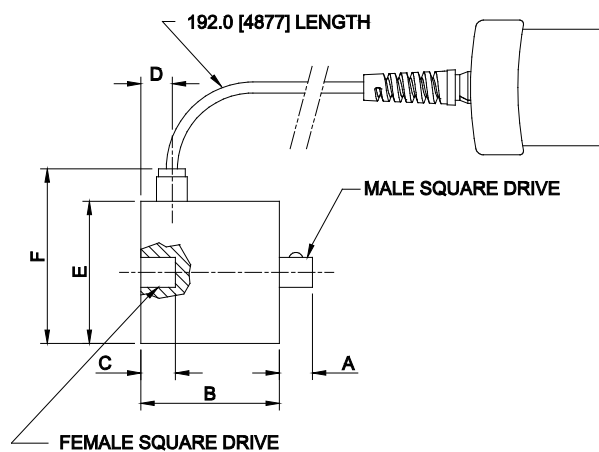

| Model No. | Drive | A | B | C | D | ØE | F |
|-----------|-------|----------------|----------------|----------------|----------------|----------------|----------------|
| MR55-20 | 1/4" | 0.30 [7.5] | 1.73 [44.0] | 0.32 [8.0] | 0.39 [10.0] | 1.77 [45.0] | 2.32 [59.0] |
| MR55-50 | | | | | | | |
| MR55-100 | | | | | | | |
| MR55-200 | 3/8" | 0.41 [10.5] | 1.73 [44.0] | 0.43 [11.0] | | | |
| MR55-400 | | | | 0.63 [16.0] | | | |
| MR55-1000 | 1/2" | 0.59 [15.0] | | | | | |
| MR55-5000 | 3/4" | 0.89 [22.5] | 2.11 [53.5] | 0.94 [24.0] | 0.77 [19.5] | 2.01 [51.0] | 2.56 [65.0] |

14.5 Capacity x Resolution

| Model No. | With Model 7i / 5i indicator | | | | | With Model 3i indicator | | |
|-----------|------------------------------|-------------|----------------|------------|-------------|-------------------------|----------------|--------------|
| | lbFin | lbFft | kgFmm | Ncm | Nm | lbFin | kgFmm | Ncm |
| MR55-20 | 20 x 0.02 | 1.5 x 0.002 | 230 x 0.2 | 220 x 0.2 | 2 x 0.002 | 20 x 0.02 | 230 x 0.2 | 220 x 0.2 |
| MR55-50 | 50 x 0.05 | 4 x 0.005 | 580 x 0.5 | 570 x 0.5 | 5.7 x 0.005 | 50 x 0.05 | 580 x 0.5 | 570 x 0.5 |
| MR55-100 | 100 x 0.1 | 8 x 0.01 | 1150 x 1 | 1150 x 1 | 11.5 x 0.01 | 100 x 0.1 | 1150 x 1 | 1150 x 1 |
| MR55-200 | 200 x 0.2 | 16 x 0.02 | 2300 x 2 | 2200 x 2 | 22 x 0.02 | 200 x 0.2 | 2300 x 2 | 2200 x 2 |
| MR55-400 | 400 x 0.5 | 32 x 0.05 | 4600 x 5 | 4500 x 5 | 45 x 0.05 | 400 x 0.5 | 4600 x 5 | 4500 x 5 |
| MR55-1000 | 1000 x 1 | 80 x 0.1 | 11500 x 10 | 11000 x 10 | 110 x 0.1 | 1000 x 1 | 11500 x 10 | 11000 x 10 |
| MR55-5000 | 5000 x 5 | 400 x 0.5 | 55 x 0.05 kgFm | 55000 x 50 | 550 x 0.5 | 5000 x 5 | 55 x 0.05 kgFm | 550 x 0.5 Nm |



Mark-10 Corporation has been an innovator in the force and torque measurement fields since 1979. We strive to achieve 100% customer satisfaction through excellence in product design, manufacturing and customer support. In addition to our standard line of products we can provide modifications and custom designs for OEM applications. Our engineering team is eager to satisfy any special requirements. Please contact us for further information or suggestions for improvement.



Force and torque measurement engineered better

Mark-10 Corporation

11 Dixon Avenue
Copiague, NY 11726 USA
1-888-MARK-TEN
Tel: 631-842-9200
Fax: 631-842-9201
Internet: www.mark-10.com
E-mail: info@mark-10.com