

Torque Test Stands Series **TS**
MODELS TST / TSTH & TSTM / TSTMH

User's Guide

MARK-10®

Thank you...



Thank you for purchasing a Mark-10 Series TS Torque Measurement Test Stand. We are confident that you will get many years of great service from this product.

Mark-10 test stands are ruggedly built for many years of service in laboratory and industrial environments.

This User's Guide provides unpacking, setup, and operator instructions for each model in the TS Torque Measurement Test Stand Series. Dimensions and specifications are also provided. For additional information or answers to your questions, our engineering and technical support teams are eager to help you.

Thank you again for your purchase and happy testing!

TABLE OF CONTENTS

GENERAL	2
Unpacking and setting up.....	2
List of included items.....	2
MODELS TST & TSTH	3
Setup and Operation	3
Specifications	3
Dimensions	4
MODELS TSTM & TSTMH	5
Safety Tips	5
Setup	5
Operation	6
Specifications	7
Dimensions	8

1 GENERAL

1.1 Unpacking and Setting up

1. Carefully unpack the test stand from the box and inspect for any damage. Check the contents to ensure that you have received a test stand complete with all accessories – see the list of included items below.
2. Remove the foam from the middle portion of the test stand and remove the plywood caps by unscrewing the pair of screws at each end. For the TST and TSTM models, install the base with four 5/16-18 x 1” screws and the top cap with two 1/4-20 x 5/8” screws. For the TSTH and TSTMH models, install the two column caps with two 1/4-20 x 5/8” screws per cap. Save all packaging materials for any future shipping.
3. Place the stand on a firm, flat and level working surface free from vibration to ensure accurate readings. It is recommended that the test stand be secured to a work bench – see your model’s “Operation” section for further details.

1.2 List of Included Items

Item	Quantity	
	TST / TSTM	TSTH /TSTMH
Torque measurement test stand	1	1
Control Unit (TSTM and TSTMH, only)	1	1
Power cord (TSTM and TSTMH, only)	1	1
Base	1	-
Column cap	1	2
5/16-18 x 1” screw for base installation	4	-
1/4-20 x 5/8” screw for column cap installation	2	4
Mounting hole drill template	1	-
Wrench set	1	1

TST / TSTH

2 SETUP AND OPERATION

1. Mount the test stand to a firm, flat, and level working surface for maximum safety and accuracy using four 5/16 screws (not included). Use the included mounting hole drill template to accurately drill the holes. Testing can take place without securing the test stand in such a manner, however, it is strongly recommended that the stand be secured, especially for high torque tests.
2. Install an appropriate sensor and/or indicator onto the slider bracket (an indicator bracket that mounts onto the test stand column is available separately).
3. Install any required attachments, grips, adapters, and other items necessary for your test sample. Ensure that these items are set up in a secure and safe manner.
4. Begin the test by turning the hand wheel in either direction. To maintain smooth operation of the hand wheel, avoid overloads.

The angle dial is adjustable relative to the torque plate. Position the ring by hand to the desired angle.

The slider's position is adjustable along the column in order to engage and disengage the test sample. Move the slider lever clockwise to lower the slider's position closer to the torque plate. The slider may be locked into position by tightening the friction brake knob located on the opposite side of the slider.

The travel stops' positions can also be adjusted. Loosen the knobs, adjust to the desired positions, and retighten.

3 SPECIFICATIONS

Load capacity:	100 lbFin [11.5 Nm]
Maximum angular travel:	No limit
Angular rate:	12°/wheel rev
Angle dial resolution:	2°
Maximum slider travel:	15.5" [394 mm]
Slider travel rate:	1.05" [26.6 mm]/lever rev
Weight (test stand only):	TST: 33 lb [15 kg], TSTH: 27 lb [12.3 kg]

3 DIMENSIONS

TST

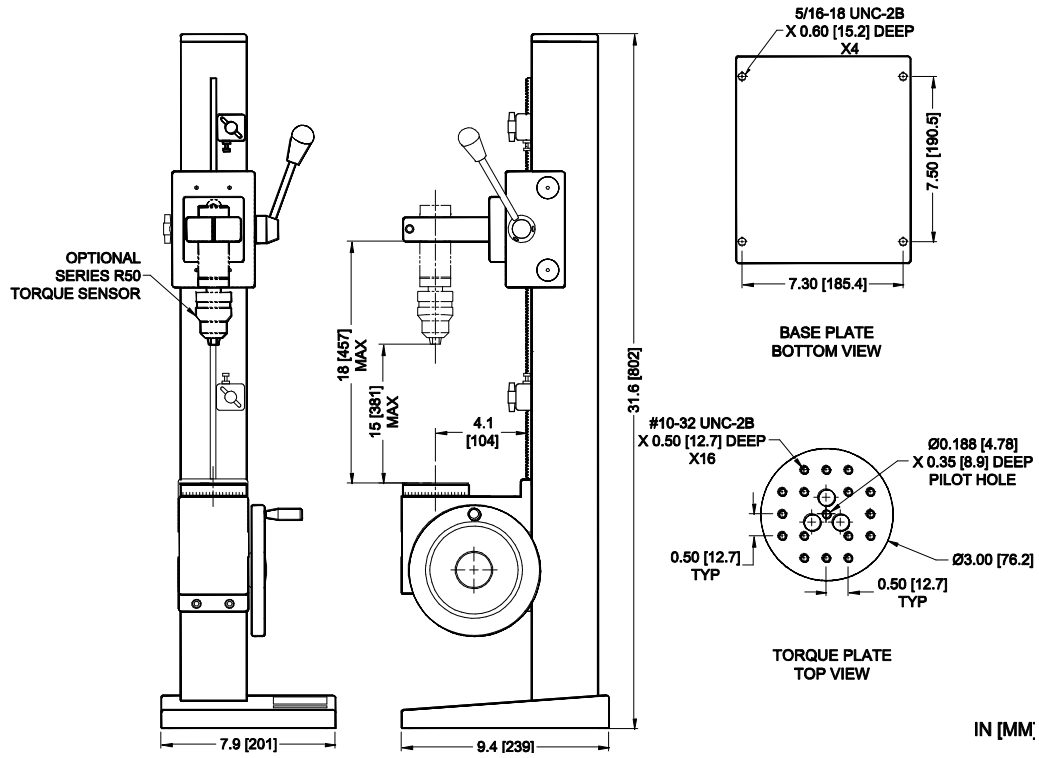

TSTH

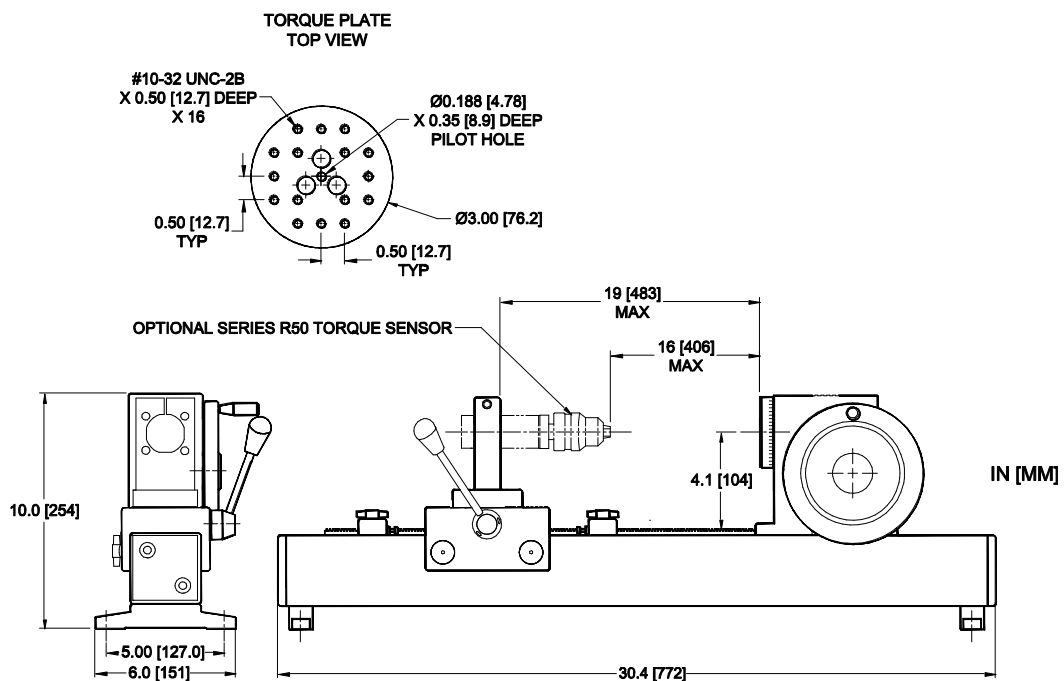

TSTM / TSTMH

4 SAFETY TIPS

- Wear eye and face protection when testing. Although the TSTM / TSTMH has relatively slow moving mechanisms, be aware of the dangers posed by potential energies that can accumulate in the sample during testing.
- Keep away from the moving parts of the test stand.
- Never operate the test stand if there is any visible damage to the power cord or the control unit. The TSTM / TSTMH is powered by 110/220 volts that are present in both the power cord and the Control Unit. Any contact with this high voltage can cause serious injury or even death.
- Ensure that the control unit be kept away from water or any other liquids at all times.
- Make sure the electrical outlet powering the test stand has local earth ground (3-hole outlet).
- If it is necessary to remove the cover of the Control Unit or motor drive, always disconnect power before doing so. Use Mark-10 replacement parts, only, if any repairs are needed.

5 SETUP

1. Mount the test stand to a firm, flat, and level working surface for maximum safety and accuracy using four 5/16 screws (not included). Use the included mounting hole drill template to accurately drill the holes. Testing can take place without securing the test stand in such a manner, however, it is strongly recommended that the stand be secured, especially for high torque tests.

With the base or legs of the TSTM / TSTMH removed, the test stand can be easily integrated into large systems such as production lines. In general, any mounting angle is feasible.

The angle dial is adjustable relative to the torque plate. Turn the dial by hand to the desired angle.

The travel stops' positions can also be adjusted. Loosen the wing nuts, adjust to the desired positions, and retighten.

2. Install an appropriate sensor onto the slider bracket. An indicator bracket that mounts onto the test stand column is available separately.
3. Install any required attachments, grips, adapters, and other items necessary for your test sample. Ensure that these items are set up in a secure and safe manner.
4. Plug the Control Unit cable into the 9-pin male connector located adjacent to the motor, then plug the power cord into the control unit and the other end into an electrical outlet with earth ground.
5. Turn on the power switch, located on the Control Unit beside the power cord in the rear of the unit. If applicable, connect the indicator to a computer or printer.
6. Recheck to ensure the sample is secured properly. The TSTM/TSTMH is now ready for use.

6 OPERATION

The slider's position is adjustable along the column in order to engage and disengage the test sample. Move the slider lever clockwise to lower the slider's position closer to the torque plate. The slider may be locked into position by tightening the friction brake knob located on the opposite side of the slider.

The test stand may be operated by motor or by hand. To begin a motorized test, use the Control Unit to operate the test stand (see instructions on the next page). For fine manual adjustment turn the knob on the motor drive in the desired direction.

Using the Standard Control Unit

CCW

Press and hold for counter-clockwise motion, release button to stop. Located on the face of the Control Unit.

CW

Press and hold for clockwise motion, release button to stop. Located on the face of the Control Unit.

SPEED CONTROL DIAL

Adjust speed by turning the dial 0.3 – 8.6 RPM (4 – 52°/s). Located on the face of the Control Unit.

POWER SWITCH

Use this switch, in the left rear of the Control Unit, to turn on and turn off power to the test stand. Power is indicated by an amber light on the face of the Control Unit.

POWER PLUG RECEPTACLE

Located in the left rear of the Control Unit. Plug the power cord in here.

CONTROL CABLE

Plug this cable into the lower male connector on the test stand, adjacent to the motor.

Using the DC4040 Control Unit

This advanced control unit is supplied with the TSTM-DC test stand. Refer to the DC Controllers user's guide for complete instructions.

7 SPECIFICATIONS

Load capacity:	TSTM: 100 lbFin [11.5 Nm] TSTM-DC: 100 lbFin [11.5 Nm] TSTM-DC with SP-2496 upgrade: 200 lbFin [22 Nm]
Speed range:	TSTM: 0.3 - 8.6 RPM [4 - 52°/s] TSTM-DC: 0.01 - 15 RPM [0.05 - 90°/s] TSTM-DC with SP-2624 upgrade: 0.04 - 60 RPM [0.2 - 360°/s] *
Speed variation with load:	±0% (Stepper motor driven)
Speed accuracy:	±5% of setting
Maximum angular travel:	No limit
Manual adjustment:	12°/knob rev
Angle indicator resolution:	2°
Maximum slider travel:	15.50" [394 mm]
Slider travel rate:	1.05" [26.6 mm] / lever rev
Line voltage:	Universal input 80-240 VAC, 50/60 Hz
Fuse type:	1.2 A, 250V, 3AG SLO BLO
Weight (without controller):	TSTM: 35.5 lb [16.1 kg], TSTMH: 29.5 lb [13.4 kg]
Standard Control Unit weight:	2.7 lb [1.2 kg]

* Maximum torque decreases proportionately with speed. Examples:

- Maximum torque at 60 RPM = 25 lbFin [2.8 Nm]
- Maximum torque at 30 RPM = 50 lbFin [5.6 Nm]

8 DIMENSIONS

in [mm]

TSTM

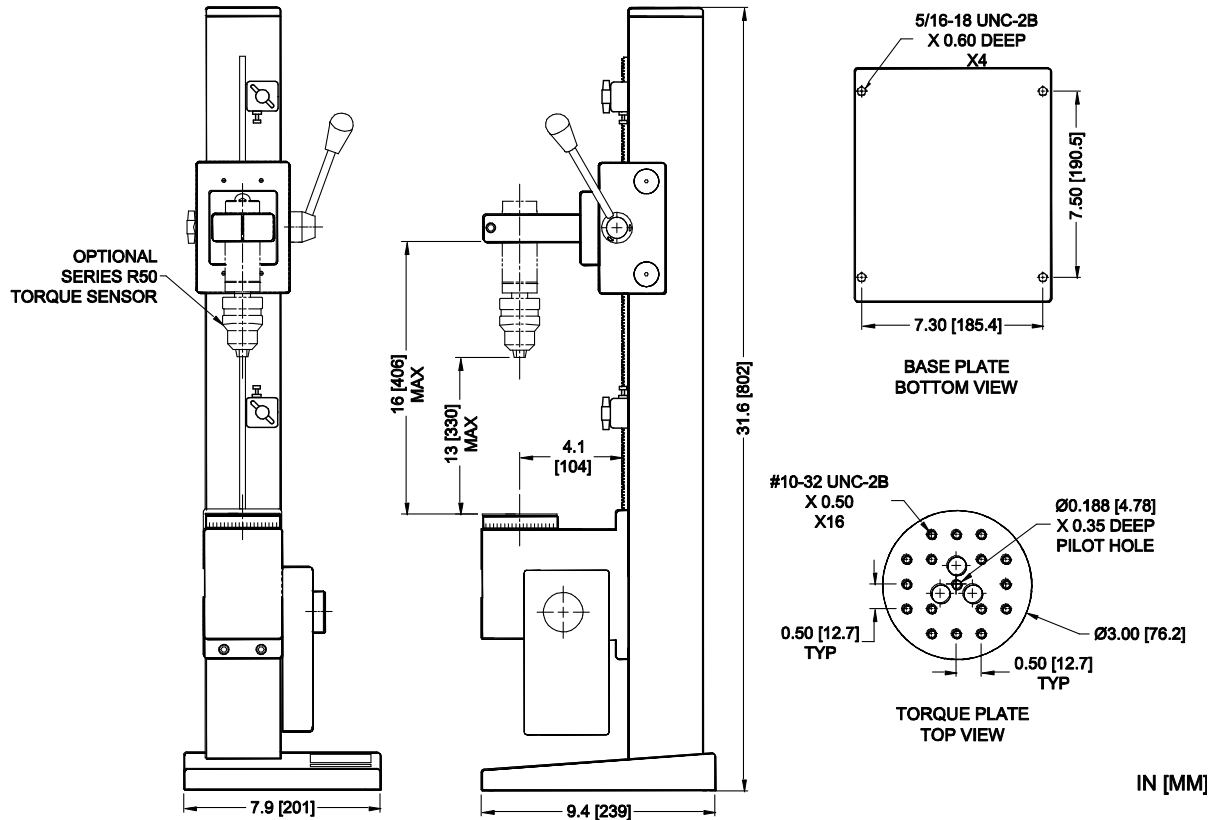

TSTMH

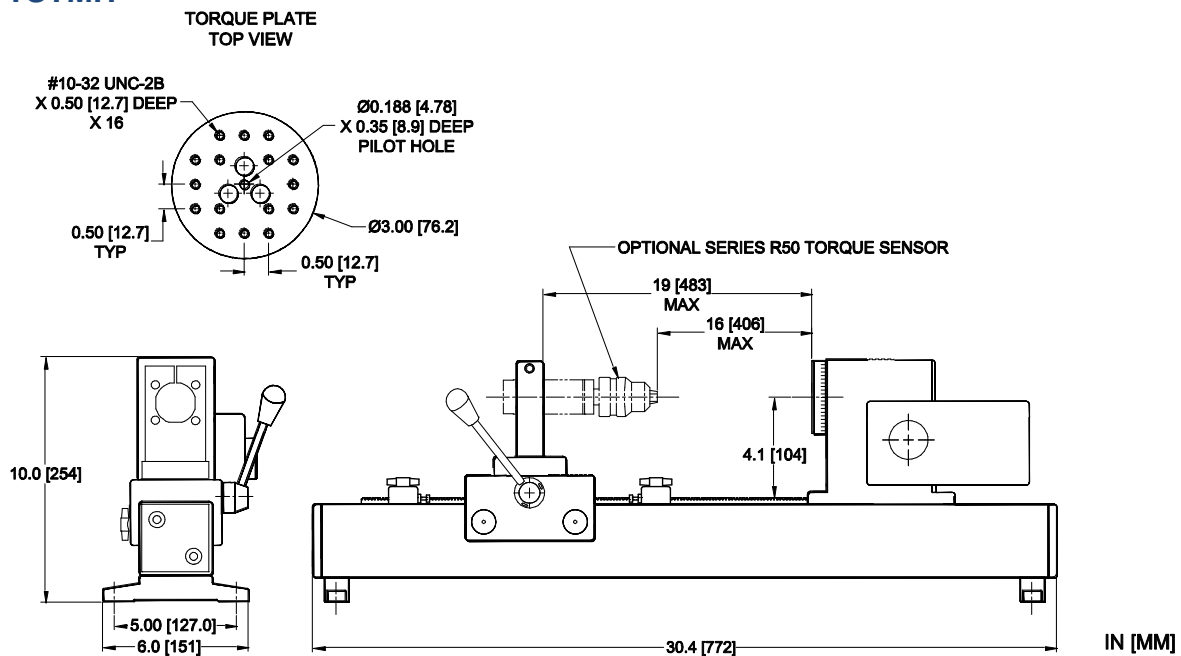



Mark-10 Corporation has been an innovator in the force and torque measurement fields since 1979. We strive to achieve 100% customer satisfaction through excellence in product design, manufacturing and customer support. In addition to our standard line of products we can provide modifications and custom designs for OEM applications. Our engineering team is eager to satisfy any special requirements. Please contact us for further information or suggestions for improvement.



We make a measurable difference in force and torque measurement

Mark-10 Corporation

11 Dixon Avenue
Copiague, NY 11726 USA
1-888-MARK-TEN
Tel: 631-842-9200
Fax: 631-842-9201
Internet: www.mark-10.com
E-mail: info@mark-10.com

32-1033
REV 4 0214