

BETA LDT-500

Dirt/Moisture Trap with Precision Vent

Operating Instructions

**Warning: The LDT-500 is designed for use
with Pneumatic Systems Only!**

Pressure Connection:

Outlet: 1/8" NPT Male Thread with O-Ring seal

Inlet: Universal 1/8" NPT Female or 1/8" BSP Female Thread

Maximum Working Pressure:

500 psi/35 bar.

Orientation:

The LDT-500 is designed to be used vertically and should be removed from the calibrator when not in use.

Media Compatibility:

Electroless Nickel over brass, Acrylic, Cast Urethane and Nitrile (Buna-N)
O-Ring seals.

Operation:

1. Fit the LDT-500 to the test port of the calibrator, hand tighten only, the o-ring at the base of the 1/8" NPT male thread will make a proper seal. Try to orient the LDT-500 so that the vent control is in position to allow ease of use.
2. Connect the equipment under test to the upper port on the LDT-500, using a suitable sealing method. Use a 7/8" or 23mm back up wrench on the hex section nearest the upper port when connecting to the LDT-500 inlet.
3. When you are ready to operate the calibrator make sure to close the vent on the LDT-500 *and* the vent on the calibrator. When using the LDT-500 the vent knob on the calibrator can remain in the closed position. All venting should be done using the vent on the LDT-500 to prevent liquids from entering the calibrator.

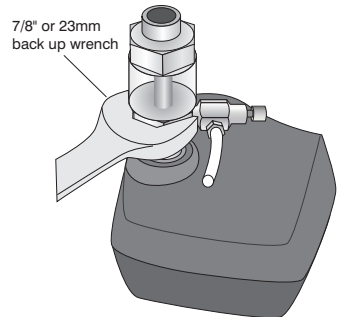
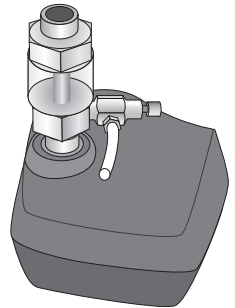

4. If moisture or dirt particles are seen within the clear chamber during use, dismantle and clean the trap.

Cleaning/Assembly:

1. Unscrew the top section of the LDT-500 then remove the clear acrylic chamber and the two o-rings.
2. Clean and dry the internal components with a clean cloth. **DO NOT USE SOLVENTS** on the clear acrylic chamber as damage may occur.
3. Before reassembly inspect the clear acrylic chamber, external and internal o-rings for wear or damage and repair by ordering replacement parts. Do not reuse worn or damaged parts.
4. Before assembly lightly lubricate the two internal o-rings with Dow 111, or silicone grease and then reassemble the LDT-500 properly. Hand tighten only.

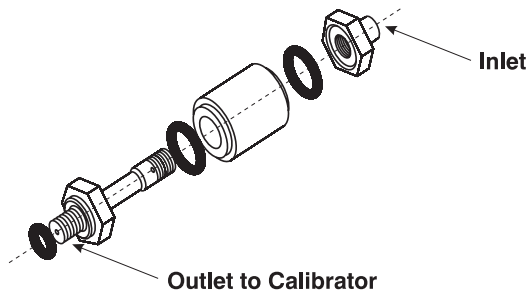

Martel Electronics Corporation
3 Corporate Park Drive, Unit # 1
Derry, NH 03038

www.martelcorp.com • e-mail: sales@martelcorp.com
Tel: (603) 434-1433 • 800-821-0023
Fax: (603) 434-1653