

## Set of 4 pegs; standard and extended lengths



### Description

These pegs attach to the upper and lower fixing tables to keep samples secure during torque testing. The extended length pegs are to keep taller samples vertically aligned.

### Applications

Used for closure torque testing of:

- Bottles
- Jars



### Specifications

Part No.	Thread 1	Diameter Ø	Length
432-447	M6	16 mm (0.63")	35 mm (1.38")
432-250	M6	16 mm (0.63")	100 mm (3.94")

## Dimensions mm (inch)

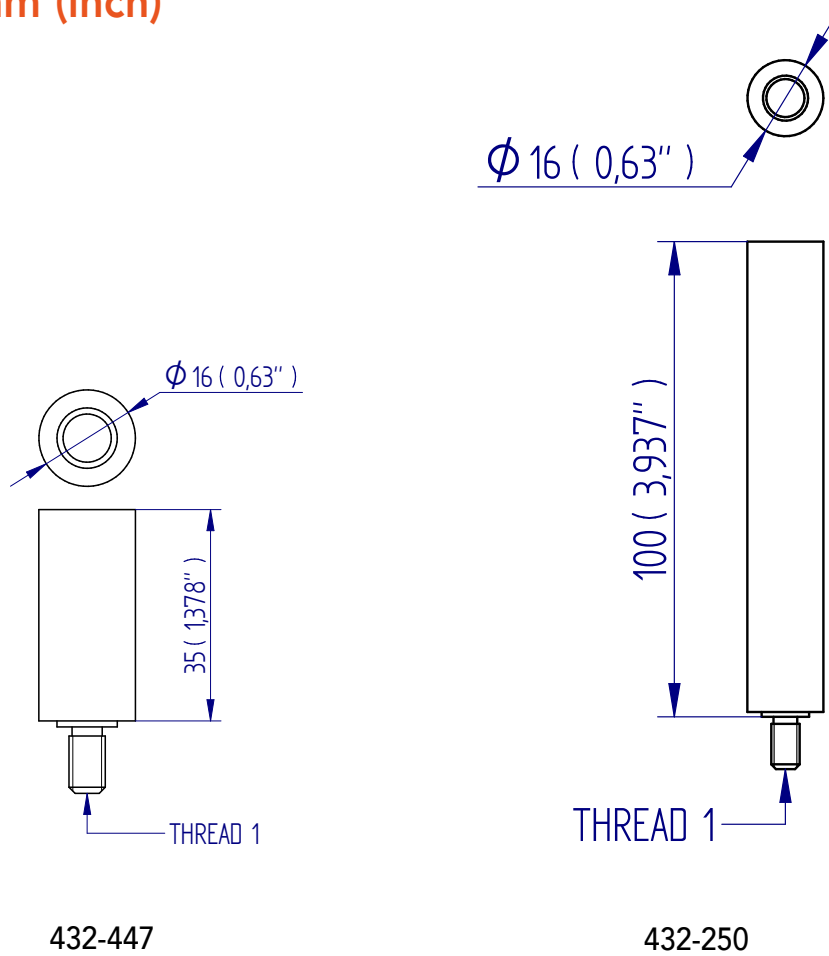

FS 58553

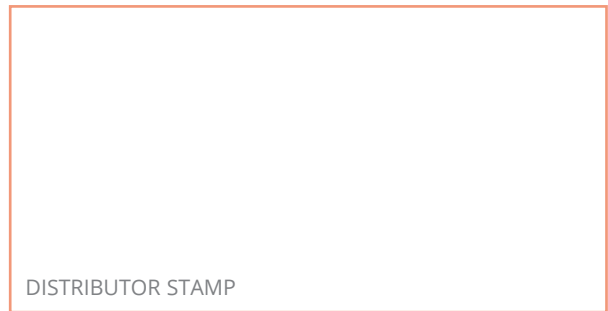

Mecmesin reserves the right to alter equipment specifications without prior notice.  
E&OE

**Head Office**  
Mecmesin Limited

w: [www.mecmesin.com](http://www.mecmesin.com)  
e: [sales@mecmesin.com](mailto:sales@mecmesin.com)

**France**  
Mecmesin France

w: [www.mecmesin.com/fr](http://www.mecmesin.com/fr)  
e: [contact@mecmesin.fr](mailto:contact@mecmesin.fr)

**Germany**  
Mecmesin GmbH

w: [www.mecmesin.com/de](http://www.mecmesin.com/de)  
e: [info@mecmesin.de](mailto:info@mecmesin.de)

**North America**  
Mecmesin Corporation

w: [www.mecmesin.com](http://www.mecmesin.com)  
e: [info@mecmesincorp.com](mailto:info@mecmesincorp.com)

**Asia**  
Mecmesin Asia Co., Ltd

w: [www.mecmesin.com/th](http://www.mecmesin.com/th)  
e: [sales@mecmesinasia.com](mailto:sales@mecmesinasia.com)

**China**  
Mecmesin (Shanghai) Pte Ltd

w: [www.mecmesin.com/zh](http://www.mecmesin.com/zh)  
e: [sales@mecmesin.cn](mailto:sales@mecmesin.cn)